

## Features

- **Ambient Light Sensing and Proximity Detection in a Single Device**
- **Ambient Light Sensing (ALS)**
  - Approximates Human Eye Response
  - Programmable Analog Gain
  - Programmable Integration Time
  - Programmable Interrupt Function with Upper and Lower Threshold
  - Resolution Up to 16 Bits
  - Very High Sensitivity — Operates Well Behind Darkened Glass
  - Up to 1,000,000:1 Dynamic Range
- **Proximity Detection**
  - Programmable Number of IR Pulses
  - Programmable Current Sink for the IR LED — No Limiting Resistor Needed
  - Programmable Interrupt Function with Upper and Lower Threshold
  - Covers a 2000:1 Dynamic Range
- **Programmable Wait Timer**
  - Programmable from 2.72 ms to > 8 Seconds
  - Wait State — 65  $\mu$ A Typical Current

## PACKAGE FN DUAL FLAT NO-LEAD (TOP VIEW)

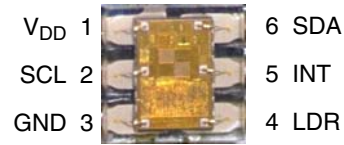

Package Image Not Actual Size

- **I<sup>2</sup>C Interface Compatible**
  - Up to 400 kHz (I<sup>2</sup>C Fast Mode)
  - Dedicated Interrupt Pin
- **Small 2 mm × 2 mm ODFN Package**
- **Sleep Mode — 2.5  $\mu$ A Typical Current**

## Applications

- **Cell Phone Backlight Dimming**
- **Cell Phone Touch Screen Disable**
- **Notebook/Monitor Security**
- **Automatic Speakerphone Enable**
- **Automatic Menu Popup**

## Description

The TSL2771 family of devices provides both ambient light sensing (ALS) and proximity detection (when coupled with an external IR LED). The ALS approximates human eye response to light intensity under a variety of lighting conditions and through a variety of attenuation materials. The proximity detection feature allows a large dynamic range of operation for use in short distance detection behind dark glass such as in a cell phone or for longer distance measurements for applications such as presence detection for monitors or laptops. The programmable proximity detection enables continuous measurements across the entire range. In addition, an internal state machine provides the ability to put the device into a low power mode in between ALS and proximity measurements providing very low average power consumption.

While useful for general purpose light sensing, the device is particularly useful for display management with the purpose of extending battery life and providing optimum viewing in diverse lighting conditions. Display panel and keyboard backlighting can account for up to 30 to 40 percent of total platform power. The ALS features are ideal for use in tablets, notebook PCs, LCD monitors, flat-panel televisions, and cell phones.

The proximity function is targeted specifically towards cell phone, LCD monitor, laptop, and flat-panel television applications. In cell phones, the proximity detection can detect when the user positions the phone close to their ear. The device is fast enough to provide proximity information at a high repetition rate needed when answering a phone call. It can also detect both close and far distances so the application can implement more complex algorithms to provide a more robust interface. In laptop or monitor applications, the product is sensitive enough to determine whether a user is in front of the laptop using the keyboard or away from the desk. This provides both improved *green* power saving capability and the added security to lock the computer when the user is not present.

# TSL2771 LIGHT-TO-DIGITAL CONVERTER with PROXIMITY SENSING

TAOS100B – FEBRUARY 2011

## Functional Block Diagram

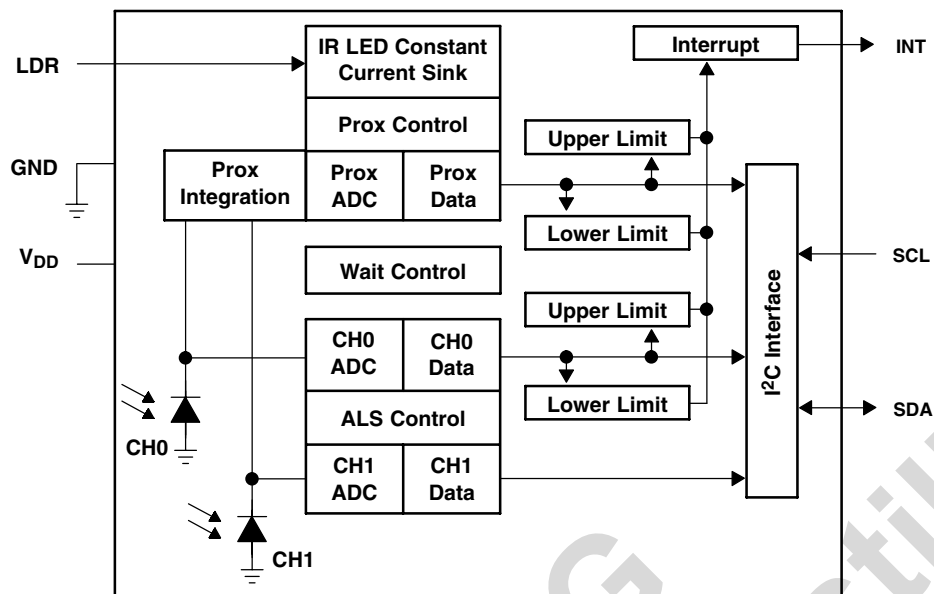

## Detailed Description

The TSL2771 light-to-digital device provides on-chip photodiodes, integrating amplifiers, ADCs, accumulators, clocks, buffers, comparators, a state machine, and an I<sup>2</sup>C interface. Each device combines a Channel 0 photodiode (CH0), which is responsive to both visible and infrared light, and a channel 1 photodiode (CH1), which is responsive primarily to infrared light. Two integrating ADCs simultaneously convert the amplified photodiode currents into a digital value providing up to 16 bits of resolution. Upon completion of the conversion cycle, the conversion result is transferred to the data registers. This digital output can be read by a microprocessor through which the illuminance (ambient light level) in Lux is derived using an empirical formula to approximate the human eye response.

Communication to the device is accomplished through a fast (up to 400 kHz), two-wire I<sup>2</sup>C serial bus for easy connection to a microcontroller or embedded controller. The digital output of the device is inherently more immune to noise when compared to an analog interface.

The device provides a separate pin for level-style interrupts. When interrupts are enabled and a pre-set value is exceeded, the interrupt pin is asserted and remains asserted until cleared by the controlling firmware. The interrupt feature simplifies and improves system efficiency by eliminating the need to poll a sensor for a light intensity or proximity value. An interrupt is generated when the value of an ALS or proximity conversion exceeds either an upper or lower threshold. In addition, a programmable interrupt persistence feature allows the user to determine how many consecutive exceeded thresholds are necessary to trigger an interrupt. Interrupt thresholds and persistence settings are configured independently for both ALS and proximity.

Proximity detection requires only a single external IR LED. An internal LED driver can be configured to provide a constant current sink of 12.5 mA, 25 mA, 50 mA, or 100 mA of current. No external current limiting resistor is required. The number of proximity LED pulses can be programmed from 1 to 255 pulses. Each pulse has a 16- $\mu$ s period. This LED current, coupled with the programmable number of pulses, provides a 2000:1 contiguous dynamic range.

### Terminal Functions

TERMINAL NAME	NO.	TYPE	DESCRIPTION
GND	3		Power supply ground. All voltages are referenced to GND.
INT	5	O	Interrupt — open drain (active low).
LDR	4	O	LED driver for proximity emitter — up to 100 mA, open drain.
SCL	2	I	I <sup>2</sup> C serial clock input terminal — clock signal for I <sup>2</sup> C serial data.
SDA	6	I/O	I <sup>2</sup> C serial data I/O terminal — serial data I/O for I <sup>2</sup> C .
V <sub>DD</sub>	1		Supply voltage.

### Available Options

DEVICE	ADDRESS	PACKAGE – LEADS	INTERFACE DESCRIPTION	ORDERING NUMBER
TSL27711	0x39	FN-6	I <sup>2</sup> C V <sub>bus</sub> = V <sub>DD</sub> Interface	TSL27711FN
TSL27713	0x39	FN-6	I <sup>2</sup> C V <sub>bus</sub> = 1.8 V Interface	TSL27713FN
TSL27715†	0x29	FN-6	I <sup>2</sup> C V <sub>bus</sub> = V <sub>DD</sub> Interface	TSL27715FN
TSL27717†	0x29	FN-6	I <sup>2</sup> C V <sub>bus</sub> = 1.8 V Interface	TSL27717FN

† Contact TAOS for availability.

### Absolute Maximum Ratings over operating free-air temperature range (unless otherwise noted)†

Supply voltage, V <sub>DD</sub> (see Note 1)	3.8 V
Digital output voltage range, V <sub>O</sub>	–0.5 V to 3.8 V
Digital output current, I <sub>O</sub>	–1 mA to 20 mA
Storage temperature range, T <sub>stg</sub>	–40°C to 85°C
ESD tolerance, human body model	2000 V

† Stresses beyond those listed under “absolute maximum ratings” may cause permanent damage to the device. These are stress ratings only, and functional operation of the device at these or any other conditions beyond those indicated under “recommended operating conditions” is not implied. Exposure to absolute-maximum-rated conditions for extended periods may affect device reliability.

NOTE 1: All voltages are with respect to GND.

### Recommended Operating Conditions

	MIN	NOM	MAX	UNIT
Supply voltage, V <sub>DD</sub>	2.6	3	3.6	V
Operating free-air temperature, T <sub>A</sub>	–30		70	°C



# TSL2771 LIGHT-TO-DIGITAL CONVERTER with PROXIMITY SENSING

TAOS100B – FEBRUARY 2011

## Operating Characteristics, $V_{DD} = 3\text{ V}$ , $T_A = 25^\circ\text{C}$ (unless otherwise noted)

PARAMETER		TEST CONDITIONS	MIN	TYP	MAX	UNIT
$I_{DD}$	Supply current	Active — LDR pulses off		175	250	$\mu\text{A}$
		Wait mode		65		
		Sleep mode — no $I^2\text{C}$ activity		2.5	4	
$V_{OL}$	INT, SDA output low voltage	3 mA sink current	0		0.4	V
		6 mA sink current	0		0.6	
$I_{LEAK}$	Leakage current, SDA, SCL, INT pins		-5		5	$\mu\text{A}$
$I_{LEAK}$	Leakage current, LDR pin		$\pm 10$			$\mu\text{A}$
$V_{IH}$	SCL, SDA input high voltage	TSL27711, TSL27715	$0.7 V_{DD}$			V
		TSL27713, TSL27717	1.25			
$V_{IL}$	SCL, SDA input low voltage	TSL27711, TSL27715	$0.3 V_{DD}$			V
		TSL27713, TSL27717	0.54			

## ALS Characteristics, $V_{DD} = 3\text{ V}$ , $T_A = 25^\circ\text{C}$ , Gain = 16, AEN = 1 (unless otherwise noted) (Notes 1, 2, 3)

PARAMETER		TEST CONDITIONS	CHANNEL	MIN	TYP	MAX	UNIT
Dark ADC count value		$E_e = 0$ , AGAIN = 120 $\times$ , ATIME = 0xDB (100 ms)	CH0	0	1	5	counts
			CH1	0	1	5	
ADC integration time step size		ATIME = 0xFF		2.58	2.72	2.9	ms
ADC Number of integration steps				1		256	steps
ADC counts per step		ATIME = 0xFF		0		1024	counts
ADC count value		ATIME = 0xC0		0		65535	counts
ADC count value		$\lambda_p = 625\text{ nm}$ , $E_e = 171.6\ \mu\text{W}/\text{cm}^2$ , ATIME = 0xF6 (27 ms) See note 2.	CH0	4000	5000	6000	counts
			CH1	790			
			CH0	4000	5000	6000	
			CH1	2800			
ADC count value ratio: CH1/CH0		$\lambda_p = 625\text{ nm}$ , ATIME = 0xF6 (27 ms) See note 2.		10.8	15.8	20.8	%
		$\lambda_p = 850\text{ nm}$ , ATIME = 0xF6 (27 ms) See note 3.		41	56	68	
$R_e$	Irradiance responsivity	$\lambda_p = 625\text{ nm}$ , ATIME = 0xF6 (27 ms) See note 2.	CH0	29.1			counts/ ( $\mu\text{W}/\text{cm}^2$ )
			CH1	4.6			
		$\lambda_p = 850\text{ nm}$ , ATIME = 0xF6 (27 ms) See note 3.	CH0	22.8			
			CH1	12.7			
Gain scaling, relative to 1 $\times$ gain setting		8 $\times$		-10		10	%
		16 $\times$		-10		10	
		120 $\times$		-10		10	

- NOTES: 1. Optical measurements are made using small-angle incident radiation from light-emitting diode optical sources. Visible 625 nm LEDs and infrared 850 nm LEDs are used for final product testing for compatibility with high-volume production.
2. The 625 nm irradiance  $E_e$  is supplied by an AlInGaP light-emitting diode with the following typical characteristics: peak wavelength  $\lambda_p = 625\text{ nm}$  and spectral halfwidth  $\Delta\lambda_{1/2} = 20\text{ nm}$ .
3. The 850 nm irradiance  $E_e$  is supplied by a GaAs light-emitting diode with the following typical characteristics: peak wavelength  $\lambda_p = 850\text{ nm}$  and spectral halfwidth  $\Delta\lambda_{1/2} = 42\text{ nm}$ .

**TSL2771**  
**LIGHT-TO-DIGITAL CONVERTER**  
**with PROXIMITY SENSING**

TAOS100B – FEBRUARY 2011

**Proximity Characteristics,  $V_{DD} = 3\text{ V}$ ,  $T_A = 25^\circ\text{C}$ , PEN = 1 (unless otherwise noted)**

PARAMETER	TEST CONDITIONS	CONDITION	MIN	TYP	MAX	UNIT
$I_{DD}$ Supply current	LDR pulse on			3		mA
ADC conversion time step size	PTIME = 0xFF		2.58	2.72	2.9	ms
ADC number of integration steps			1		256	steps
ADC counts per step	PTIME = 0xFF		0		1023	counts
IR LED pulse count			0		255	pulses
pulse period	Two or more pulses			16		$\mu\text{s}$
LED pulse width — LED on time				7.3		$\mu\text{s}$
LED drive current	$I_{SINK}$ sink current @ 600 mV, LDR pin	PDRIVE=0	75	100	125	mA
		PDRIVE=1		50		
		PDRIVE=2		25		
		PDRIVE=3		12.5		
Operating distance (See note 1)				18		inches

NOTE 1: Proximity Operating Distance is dependent upon emitter properties and the reflective properties of the proximity surface. The nominal value shown uses an IR emitter with a peak wavelength of 850nm and a 20° half angle. The proximity surface used is a 90% reflective (white surface) 16 × 20-inch Kodak Gray Card. 60 mw/SR, 100 mA, 64 pulses, open view (no glass). **Note:** Greater distances are achievable with appropriate system considerations.

**Wait Characteristics,  $V_{DD} = 3\text{ V}$ ,  $T_A = 25^\circ\text{C}$ , WEN = 1 (unless otherwise noted)**

PARAMETER	TEST CONDITIONS	CHANNEL	MIN	TYP	MAX	UNIT
Wait step size	WTIME = 0xFF		2.58	2.72	2.9	ms
Wait number of integration steps			1		256	steps

**AC Electrical Characteristics,  $V_{DD} = 3\text{ V}$ ,  $T_A = 25^\circ\text{C}$  (unless otherwise noted)**

PARAMETER†	TEST CONDITIONS	MIN	TYP	MAX	UNIT
$f_{(SCL)}$ Clock frequency (I <sup>2</sup> C only)		0		400	kHz
$t_{(BUF)}$ Bus free time between start and stop condition		1.3			$\mu\text{s}$
$t_{(HDSTA)}$ Hold time after (repeated) start condition. After this period, the first clock is generated.		0.6			$\mu\text{s}$
$t_{(SUSTA)}$ Repeated start condition setup time		0.6			$\mu\text{s}$
$t_{(SUSTO)}$ Stop condition setup time		0.6			$\mu\text{s}$
$t_{(HDDAT)}$ Data hold time		0			$\mu\text{s}$
$t_{(SUDAT)}$ Data setup time		100			ns
$t_{(LOW)}$ SCL clock low period		1.3			$\mu\text{s}$
$t_{(HIGH)}$ SCL clock high period		0.6			$\mu\text{s}$
$t_F$ Clock/data fall time				300	ns
$t_R$ Clock/data rise time				300	ns
$C_i$ Input pin capacitance				10	pF

† Specified by design and characterization; not production tested.

**TSL2771**  
**LIGHT-TO-DIGITAL CONVERTER**  
**with PROXIMITY SENSING**

TAOS100B – FEBRUARY 2011

**PARAMETER MEASUREMENT INFORMATION**

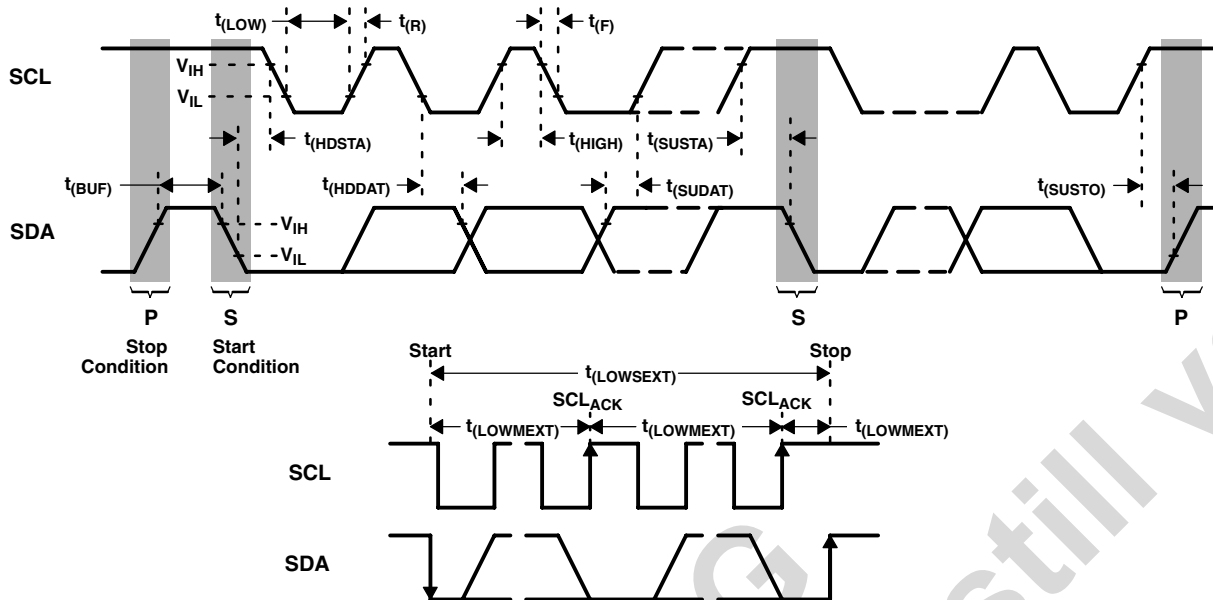

**Figure 1. Timing Diagrams**

TYPICAL CHARACTERISTICS

SPECTRAL RESPONSIVITY

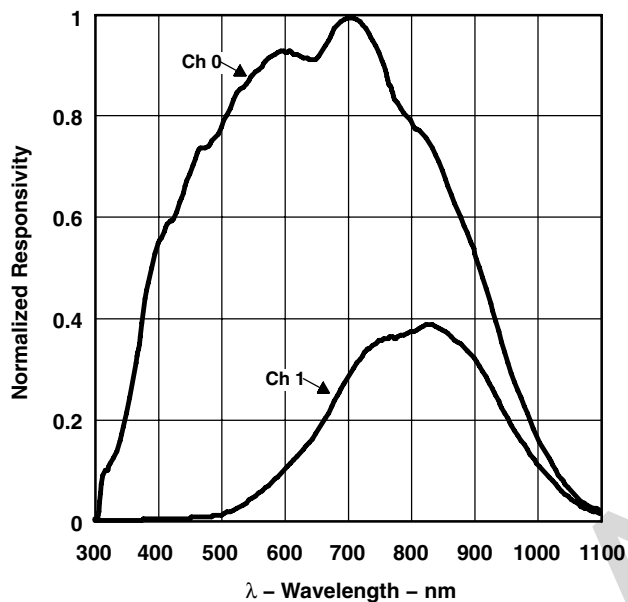

Figure 2

TYPICAL LDR CURRENT vs. VOLTAGE

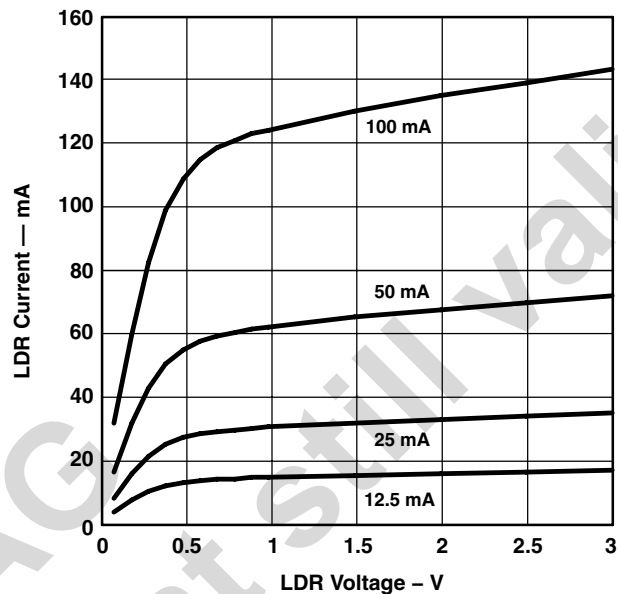

Figure 3

NORMALIZED  $I_{DD}$  vs.  $V_{DD}$  and TEMPERATURE

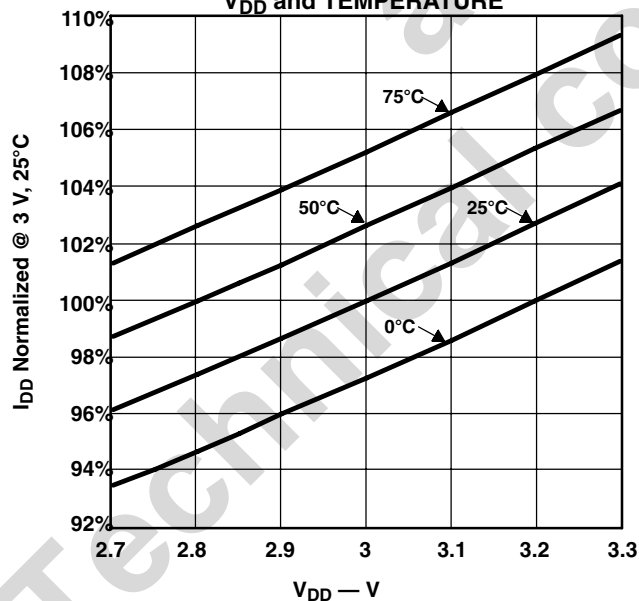

Figure 4

NORMALIZED RESPONSIVITY vs. ANGULAR DISPLACEMENT

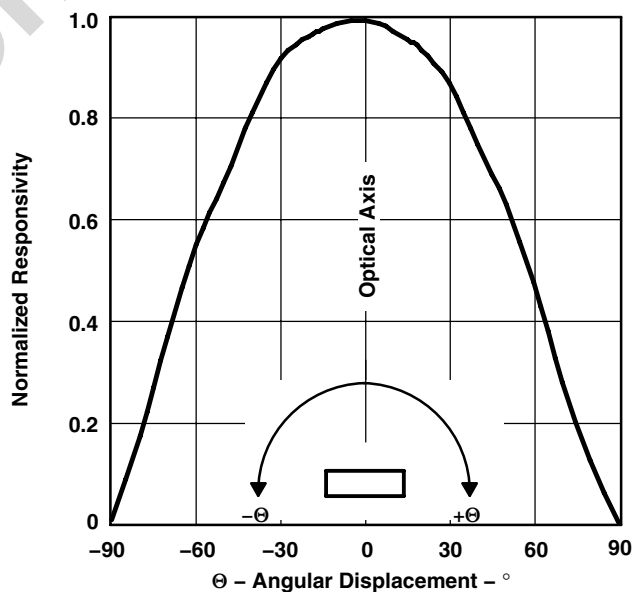
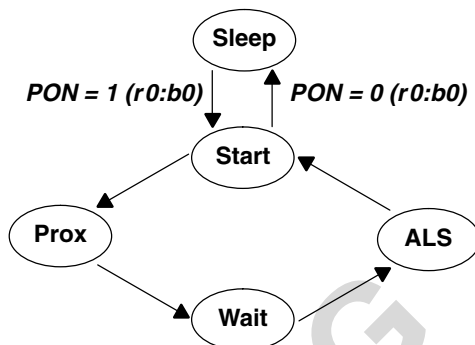

Figure 5

## PRINCIPLES OF OPERATION

### System State Machine

The device provides control of ALS, proximity detection, and power management functionality through an internal state machine (Figure 6). After a power-on-reset, the device is in the sleep mode. As soon as the PON bit is set, the device will move to the start state. It will then continue through the Prox, Wait, and ALS states. If these states are enabled, the device will execute each function. If the PON bit is set to 0, the state machine will continue until all conversions are completed and then go into a low power sleep mode.



**Figure 6. Simplified State Diagram**

**NOTE:** In this document, the nomenclature uses the bit field name in italics followed by the register number and bit number to allow the user to easily identify the register and bit that controls the function. For example, the power on (PON) is in register 0, bit 0. This is represented as *PON (r0:b0)*.

### Photodiodes

Conventional silicon detectors respond strongly to infrared light, which the human eye does not see. This can lead to significant error when the infrared content of the ambient light is high (such as with incandescent lighting) due to the difference between the silicon detector response and the brightness perceived by the human eye.

This problem is overcome through the use of two photodiodes. The Channel 0 photodiode, referred to as the CH0 channel, is sensitive to both visible and infrared light, while the Channel 1 photodiode, referred to as CH1, is sensitive primarily to infrared light. Two integrating ADCs convert the photodiode currents to digital outputs. The ADC digital outputs from the two channels are used in a formula to obtain a value that approximates the human eye response in units of lux.



## ALS Operation

The ALS engine contains ALS gain control (AGAIN) and two integrating analog-to-digital converters (ADC) for the Channel 0 and Channel 1 photodiodes. The ALS integration time (ATIME) impacts both the resolution and the sensitivity of the ALS reading. Integration of both channels occurs simultaneously and upon completion of the conversion cycle, the results are transferred to the data registers (C0DATA and C1DATA). This data is also referred to as channel *count*. The transfers are double-buffered to ensure data integrity.

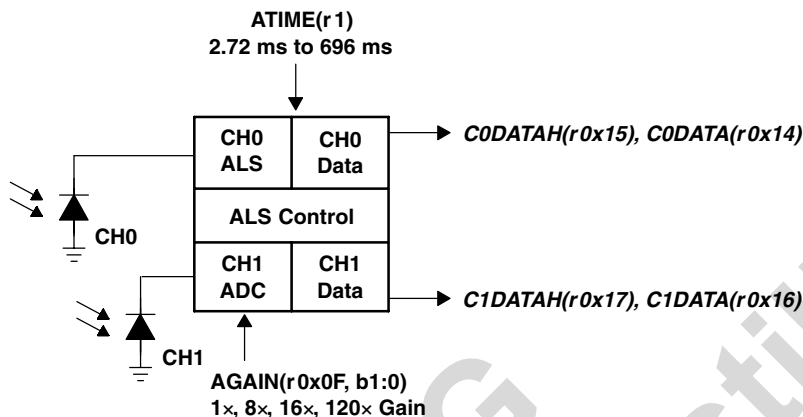

Figure 7. ALS Operation

The registers for programming the integration and wait times are a 2's complement values. The actual time can be calculated as follows:

$$ATIME = 256 - \text{Integration Time} / 2.72 \text{ ms}$$

Inversely, the time can be calculated from the register value as follows:

$$\text{Integration Time} = 2.72 \text{ ms} \times (256 - ATIME)$$

In order to reject 50/60-Hz ripple strongly present in fluorescent lighting, the integration time needs to be programmed in multiples of 10 / 8.3 ms or the half cycle time. Both frequencies can be rejected with a programmed value of 50 ms (ATIME = 0xED) or multiples of 50 ms (i.e. 100, 150, 200, 400, 600).

The registers for programming the AGAIN hold a two-bit value representing a gain of 1×, 8×, 16×, or 120×. The gain, in terms of amount of gain, will be represented by the value AGAINx, i.e. AGAINx = 1, 8, 16, or 120.

## Lux Equation

The lux calculation is a function of CH0 channel count (C0DATA), CH1 channel count (C1DATA), ALS gain (AGAINx), and ALS integration time in milliseconds (ATIME\_ms). If an aperture, glass/plastic, or a light pipe attenuates the light equally across the spectrum (300 nm to 1100 nm), then a scaling factor referred to as glass attenuation (GA) can be used to compensate for attenuation. For a device in open air with no aperture or glass/plastic above the device, GA = 1. If it is not spectrally flat, then a custom lux equation with new coefficients should be generated. (See TAOS application note).

Counts per Lux (CPL) needs to be calculated only when ATIME or AGAIN is changed, otherwise it remains a constant. The first segment of the equation (Lux1) covers fluorescent and incandescent light. The second segment (Lux2) covers dimmed incandescent light. The final lux is the maximum of Lux1, Lux2, or 0.

$$\begin{aligned} CPL &= (ATIME\_ms \times AGAINx) / (GA \times 53) \\ Lux1 &= (C0DATA - 2 \times C1DATA) / CPL \\ Lux2 &= (0.6 \times C0DATA - C1DATA) / CPL \\ Lux &= \text{MAX}(Lux1, Lux2, 0) \end{aligned}$$

# TSL2771 LIGHT-TO-DIGITAL CONVERTER with PROXIMITY SENSING

TAOS100B – FEBRUARY 2011

## Proximity Detection

Proximity sensing uses an external light source (generally an infrared emitter) to emit light, which is then viewed by the integrated light detector to measure the amount of reflected light when an object is in the light path (Figure 8). The amount of light detected from a reflected surface can then be used to determine an object's proximity to the sensor.

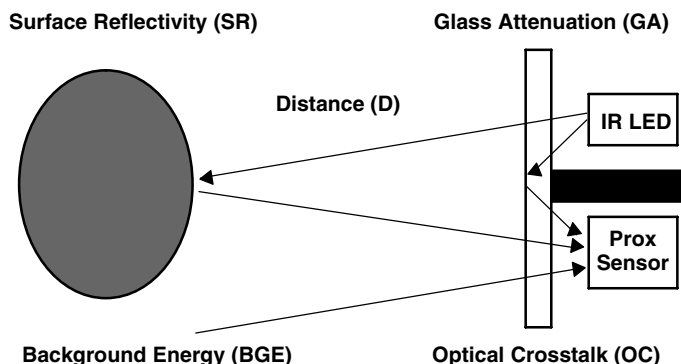

Figure 8. Proximity Detection

The device has controls for the number of IR pulses (PPCOUNT), the integration time (PTIME), the LED drive current (PDRIVE), and the photodiode configuration (PDIODE) (Figure 9). The photodiode configuration can be set to CH1 diode (recommended), CH0 diode, or a combination of both diodes. At the end of the integration cycle, the results are latched into the proximity data (PDATA) register.

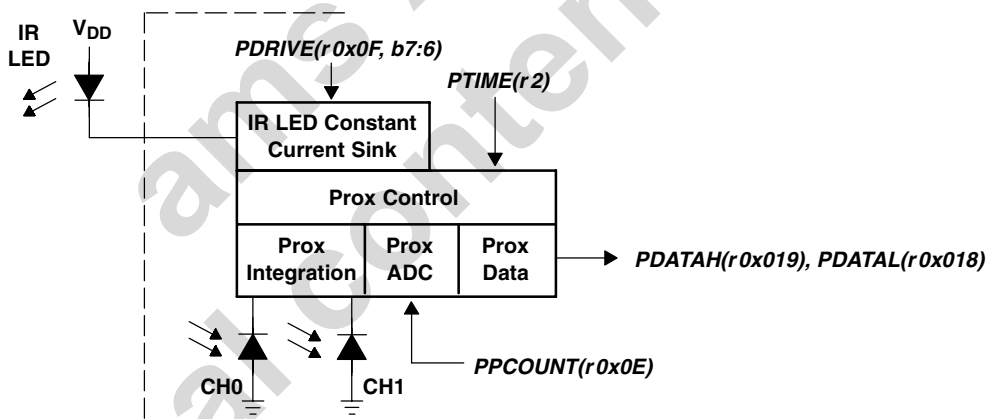
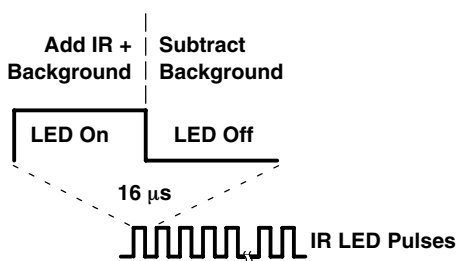

Figure 9. Proximity Detection Operation

The LED drive current is controlled by a regulated current sink on the LDR pin. This feature eliminates the need to use a current limiting resistor to control LED current. The LED drive current can be configured for 12.5 mA, 25 mA, 50 mA, or 100 mA. For higher LED drive requirements, an external P type transistor can be used to control the LED current.

The number of LED pulses can be programmed to any value between 1 and 255 pulses as needed. Increasing the number of LED pulses at a given current will increase the sensor sensitivity. Sensitivity grows by the square root of the number of pulses. Each pulse has a 16- $\mu$ s period.



**Figure 10. Proximity IR LED Waveform**

The proximity integration time (PTIME) is the period of time that the internal ADC converts the analog signal to a digital count. It is recommended that this be set to a minimum of PTIME = 0xFF or 2.72 ms.

The combination of LED power and number of pulses can be used to control the distance at which the sensor can detect proximity. Figure 11 shows an example of the distances covered with settings such that each curve covers 2 $\times$  the distance. Counts up to 64 pulses provide a 16 $\times$  range.

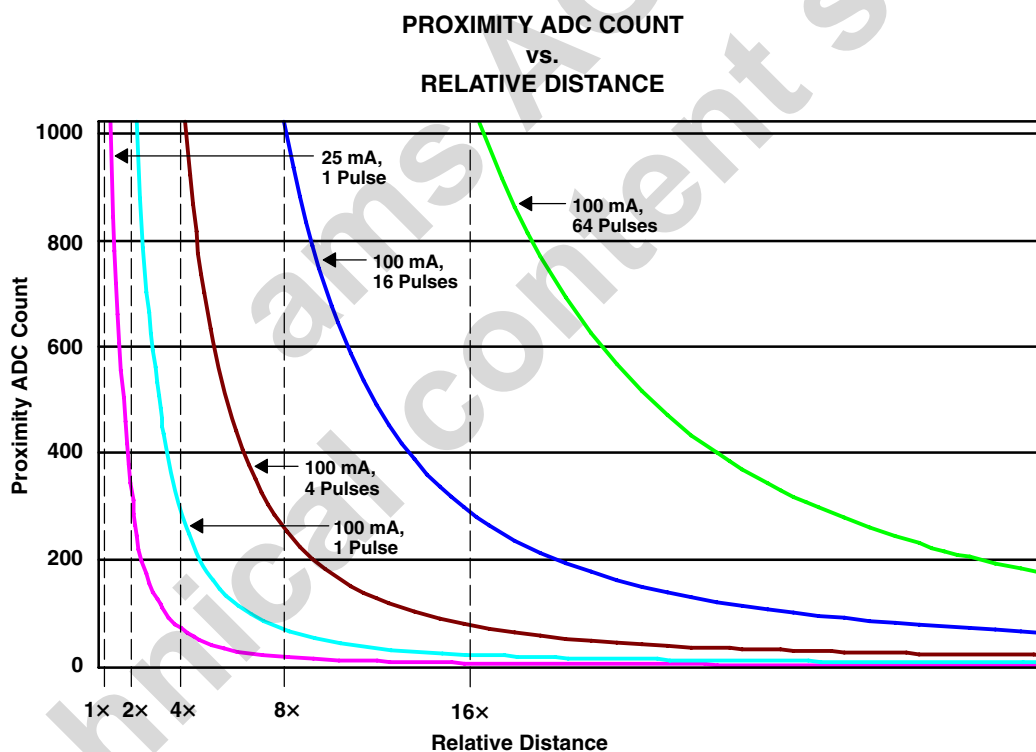

**Figure 11**

# TSL2771 LIGHT-TO-DIGITAL CONVERTER with PROXIMITY SENSING

TAOS100B – FEBRUARY 2011

## Interrupts

The interrupt feature simplifies and improves system efficiency by eliminating the need to poll the sensor for light intensity or proximity values outside of a user-defined range. While the interrupt function is always enabled and its status is available in the status register (0x13), the output of the interrupt state can be enabled using the proximity interrupt enable (PIEN) or ALS interrupt enable (AIEN) fields in the enable register (0x00).

Four 16-bit interrupt threshold registers allow the user to set limits below and above a desired light level and proximity range. An interrupt can be generated when the ALS CH0 data (C0DATA) falls outside of the desired light level range, as determined by the values in the ALS interrupt low threshold registers (AILTx) and ALS interrupt high threshold registers (AIHTx). Likewise, an out-of-range proximity interrupt can be generated when the proximity data (PDATA) falls below the proximity interrupt low threshold (PILTx) or exceeds the proximity interrupt high threshold (PIHTx). It is important to note that the low threshold value must be less than the high threshold value for proper operation.

To further control when an interrupt occurs, the device provides a persistence filter. The persistence filter allows the user to specify the number of consecutive out-of-range ALS or proximity occurrences before an interrupt is generated. The persistence register (0x0C) allows the user to set the ALS persistence (APERS) and the proximity persistence (PPERS) values. See the persistence register for details on the persistence filter values. Once the persistence filter generates an interrupt, it will continue until a special function interrupt clear command is received (see command register).

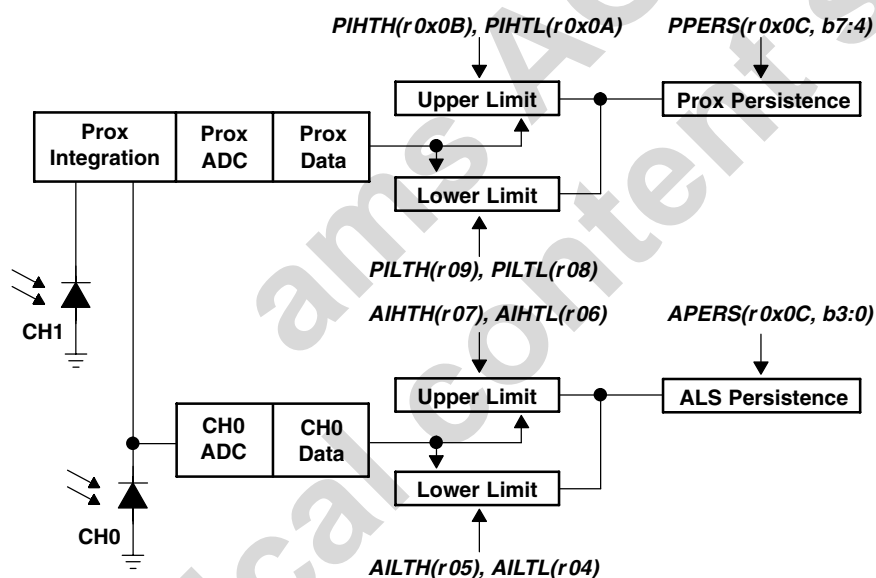

Figure 12. Programmable Interrupt

**State Diagram**

Figure 13 shows a more detailed flow for the state machine. The device starts in the sleep mode. The PON bit is written to enable the device. A 2.72-ms delay will occur before entering the start state. If the PEN bit is set, the state machine will step through the proximity states of proximity accumulate and then proximity ADC conversion. As soon as the conversion is complete, the state machine will move to the following state.

If the WEN bit is set, the state machine will then cycle through the wait state. If the WLONG bit is set, the wait cycles are extended by 12X over normal operation. When the wait counter terminates, the state machine will step to the ALS state.

The AEN should always be set, even in proximity-only operation. In this case, a minimum of 1 integration time step should be programmed. The ALS state machine will continue until it reaches the terminal count at which point the data will be latched in the ALS register and the interrupt set, if enabled.

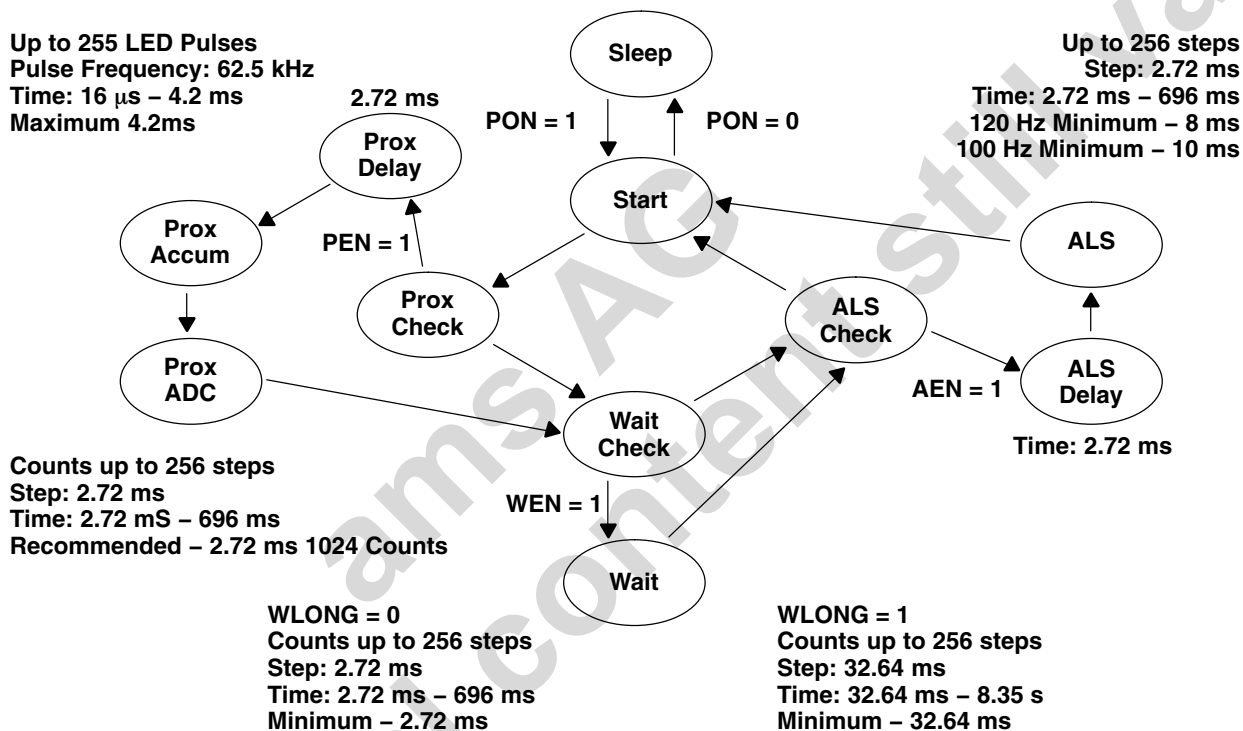

Figure 13. Expanded State Diagram

# TSL2771 LIGHT-TO-DIGITAL CONVERTER with PROXIMITY SENSING

TAOS100B – FEBRUARY 2011

## Power Management

Power consumption can be controlled through the use of the wait state timing because the wait state consumes only 65  $\mu\text{A}$  of power. Figure 14 shows an example of using the power management feature to achieve an average power consumption of 155  $\mu\text{A}$  current with four 100-mA pulses of proximity detection and 50 ms of ALS detection.

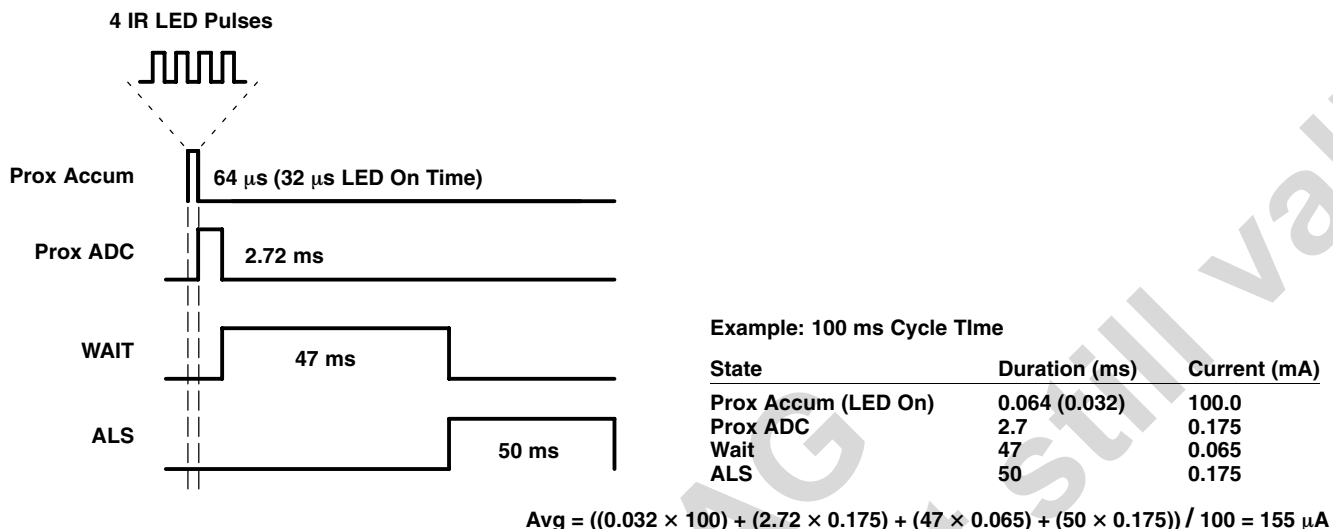

Figure 14. Power Consumption Calculations

## I<sup>2</sup>C Protocol

Interface and control are accomplished through an I<sup>2</sup>C serial compatible interface (standard or fast mode) to a set of registers that provide access to device control functions and output data. The devices support the 7-bit I<sup>2</sup>C addressing protocol.

The I<sup>2</sup>C standard provides for three types of bus transaction: read, write, and a combined protocol (Figure 15). During a write operation, the first byte written is a command byte followed by data. In a combined protocol, the first byte written is the command byte followed by reading a series of bytes. If a read command is issued, the register address from the previous command will be used for data access. Likewise, if the MSB of the command is not set, the device will write a series of bytes at the address stored in the last valid command with a register address. The command byte contains either control information or a 5-bit register address. The control commands can also be used to clear interrupts.

The I<sup>2</sup>C bus protocol was developed by Philips (now NXP). For a complete description of the I<sup>2</sup>C protocol, please review the NXP I<sup>2</sup>C design specification at <http://www.i2c-bus.org/references/>.

- A** Acknowledge (0)
- N** Not Acknowledged (1)
- P** Stop Condition
- R** Read (1)
- S** Start Condition
- S** Repeated Start Condition
- W** Write (0)
- ...** Continuation of protocol
- Master-to-Slave
- Slave-to-Master

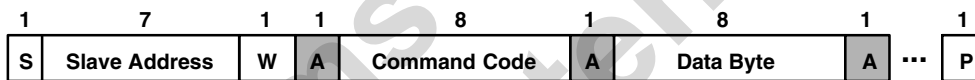

I<sup>2</sup>C Write Protocol



I<sup>2</sup>C Read Protocol

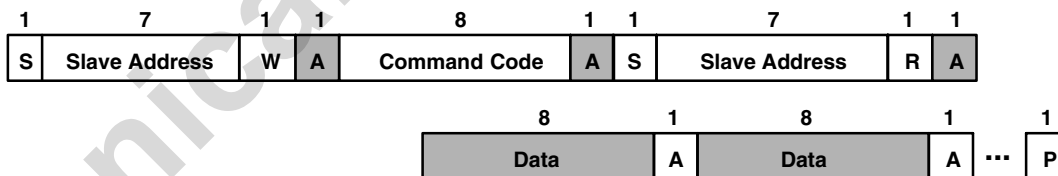

I<sup>2</sup>C Read Protocol — Combined Format

Figure 15. I<sup>2</sup>C Protocols

# TSL2771 LIGHT-TO-DIGITAL CONVERTER with PROXIMITY SENSING

TAOS100B – FEBRUARY 2011

## Register Set

The TSL2771 is controlled and monitored by data registers and a command register accessed through the serial interface. These registers provide for a variety of control functions and can be read to determine results of the ADC conversions. The register set is summarized in Table 1.

**Table 1. Register Address**

ADDRESS	REGISTER NAME	R/W	REGISTER FUNCTION	RESET VALUE
--	COMMAND	W	Specifies register address	0x00
0x00	ENABLE	R/W	Enables states and interrupts	0x00
0x01	ATIME	R/W	ALS ADC time	0xFF
0x02	PTIME	R/W	Proximity ADC time	0xFF
0x03	WTIME	R/W	Wait time	0xFF
0x04	AILTL	R/W	ALS interrupt low threshold low byte	0x00
0x05	AILTH	R/W	ALS interrupt low threshold high byte	0x00
0x06	AIHTL	R/W	ALS interrupt high threshold low byte	0x00
0x07	AIHTH	R/W	ALS interrupt high threshold high byte	0x00
0x08	PILTL	R/W	Proximity interrupt low threshold low byte	0x00
0x09	PILTH	R/W	Proximity interrupt low threshold high byte	0x00
0x0A	PIHTL	R/W	Proximity interrupt high threshold low byte	0x00
0x0B	PIHTH	R/W	Proximity interrupt high threshold high byte	0x00
0x0C	PERS	R/W	Interrupt persistence filters	0x00
0x0D	CONFIG	R/W	Configuration	0x00
0x0E	PPCOUNT	R/W	Proximity pulse count	0x00
0x0F	CONTROL	R/W	Control register	0x00
0x12	ID	R	Device ID	ID
0x13	STATUS	R	Device status	0x00
0x14	C0DATA	R	CH0 ADC low data register	0x00
0x15	C0DATAH	R	CH0 ADC high data register	0x00
0x16	C1DATA	R	CH1 ADC low data register	0x00
0x17	C1DATAH	R	CH1 ADC high data register	0x00
0x18	PDATA	R	Proximity ADC low data register	0x00
0x19	PDATAH	R	Proximity ADC high data register	0x00

The mechanics of accessing a specific register depends on the specific protocol used. See the section on I<sup>2</sup>C protocols on the previous pages. In general, the COMMAND register is written first to specify the specific control/status register for following read/write operations.



## Command Register

The command registers specifies the address of the target register for future write and read operations.

**Table 2. Command Register**

	7	6	5	4	3	2	1	0	
<b>COMMAND</b>	<b>COMMAND</b>	<b>TYPE</b>		<b>ADD</b>				--	

FIELD	BITS	DESCRIPTION	
COMMAND	7	Select Command Register. Must write as 1 when addressing COMMAND register.	
TYPE	6:5	Selects type of transaction to follow in subsequent data transfers:	
		<b>FIELD VALUE</b>	<b>DESCRIPTION</b>
		00	Repeated byte protocol transaction
		01	Auto-increment protocol transaction
		10	Reserved — Do not use
		11	Special function — See description below
		Transaction type 00 will repeatedly read the same register with each data access. Transaction type 01 will provide an auto-increment function to read successive register bytes.	
ADD	4:0	Address register/special function field. Depending on the transaction type, see above, this field either specifies a special function command or selects the specific control-status-register for the following write and read transactions. The field values listed below apply only to special function commands:	
		<b>FIELD VALUE</b>	<b>DESCRIPTION</b>
		00000	Normal — no action
		00101	Proximity interrupt clear
		00110	ALS interrupt clear
		00111	Proximity and ALS interrupt clear
other	Reserved — Do not write		
		ALS/Proximity Interrupt Clear clears any pending ALS/Proximity interrupt. This special function is self clearing.	

**TSL2771**  
**LIGHT-TO-DIGITAL CONVERTER**  
**with PROXIMITY SENSING**

TAOS100B – FEBRUARY 2011

**Enable Register (0x00)**

The ENABLE register is used to power the device on/off, enable functions, and interrupts.

**Table 3. Enable Register**

	7	6	5	4	3	2	1	0	
ENABLE	Reserved		PIEN	AIEN	WEN	PEN	AEN	PON	Address 0x00

FIELD	BITS	DESCRIPTION
Reserved	7:6	Reserved. Write as 0.
PIEN	5	Proximity interrupt mask. When asserted, permits proximity interrupts to be generated.
AIEN	4	ALS interrupt mask. When asserted, permits ALS interrupts to be generated.
WEN	3	Wait Enable. This bit activates the wait feature. Writing a 1 activates the wait timer. Writing a 0 disables the wait timer.
PEN	2	Proximity enable. This bit activates the proximity function. Writing a 1 enables proximity. Writing a 0 disables proximity.
AEN	1	ALS Enable. This bit activates the two channel ADC. Writing a 1 activates the ALS. Writing a 0 disables the ALS.
PON <sup>1, 2</sup>	0	Power ON. This bit activates the internal oscillator to permit the timers and ADC channels to operate. Writing a 1 activates the oscillator. Writing a 0 disables the oscillator.

- NOTES: 1. See Power Management section for more information.  
2. A minimum interval of 2.72 ms must pass after PON is asserted before either a proximity or ALS can be initiated. This required time is enforced by the hardware in cases where the firmware does not provide it.

### ALS Timing Register (0x01)

The ALS timing register controls the internal integration time of the ALS channel ADCs in 2.72 ms increments.

**Table 4. ALS Timing Register**

FIELD	BITS	DESCRIPTION			
		VALUE	INTEG_CYCLES	TIME	MAX COUNT
ATIME	7:0	0xFF	1	2.72 ms	1024
		0xF6	10	27.2 ms	10240
		0xDB	37	101 ms	37888
		0xC0	64	174 ms	65535
		0x00	256	696 ms	65535

### Proximity Time Control Register (0x02)

The proximity timing register controls the integration time of the proximity ADC in 2.72 ms increments. It is recommended that this register be programmed to a value of 0xFF (1 integration cycle).

**Table 5. Proximity Time Control Register**

FIELD	BITS	DESCRIPTION			
		VALUE	INTEG_CYCLES	TIME	MAX COUNT
PTIME	7:0	0xFF	1	2.72 ms	1023

### Wait Time Register (0x03)

Wait time is set 2.72 ms increments unless the WLONG bit is asserted in which case the wait times are 12x longer. WTIME is programmed as a 2's complement number.

**Table 6. Wait Time Register**

FIELD	BITS	DESCRIPTION			
		REGISTER VALUE	WAIT TIME	TIME (WLONG = 0)	TIME (WLONG = 1)
WTIME	7:0	0xFF	1	2.72 ms	0.032 sec
		0xB6	74	201 ms	2.4 sec
		0x00	256	696 ms	8.3 sec

NOTE: The Proximity Wait Time Register should be configured before PEN and/or AEN is/are asserted.

# TSL2771 LIGHT-TO-DIGITAL CONVERTER with PROXIMITY SENSING

TAOS100B – FEBRUARY 2011

## ALS Interrupt Threshold Registers (0x04 – 0x07)

The ALS interrupt threshold registers provides the values to be used as the high and low trigger points for the comparison function for interrupt generation. If C0DATA crosses below the low threshold specified, or above the higher threshold, an interrupt is asserted on the interrupt pin.

Table 7. ALS Interrupt Threshold Register

REGISTER	ADDRESS	BITS	DESCRIPTION
AILTL	0x04	7:0	ALS low threshold lower byte
AILTH	0x05	7:0	ALS low threshold upper byte
AIHTL	0x06	7:0	ALS high threshold lower byte
AIHTH	0x07	7:0	ALS high threshold upper byte

## Proximity Interrupt Threshold Registers (0x08 – 0x0B)

The proximity interrupt threshold registers provide the values to be used as the high and low trigger points for the comparison function for interrupt generation. If the value generated by proximity channel crosses below the lower threshold specified, or above the higher threshold, an interrupt is signaled to the host processor.

Table 8. Proximity Interrupt Threshold Register

REGISTER	ADDRESS	BITS	DESCRIPTION
PILTL	0x08	7:0	Proximity low threshold lower byte
PILTH	0x09	7:0	Proximity low threshold upper byte
PIHTL	0x0A	7:0	Proximity high threshold lower byte
PIHTH	0x0B	7:0	Proximity high threshold upper byte

**Persistence Register (0x0C)**

The persistence register controls the filtering interrupt capabilities of the device. Configurable filtering is provided to allow interrupts to be generated after each ADC integration cycle or if the ADC integration has produced a result that is outside of the values specified by threshold register for some specified amount of time. Separate filtering is provided for proximity and ALS functions. ALS interrupts are generated using CODATA.

**Table 9. Persistence Register**

	7	6	5	4	3	2	1	0	
<b>PERS</b>	<b>PPERS</b>						<b>APERS</b>		<b>Address 0x0C</b>
<b>FIELD</b>	<b>BITS</b>	<b>DESCRIPTION</b>							
PPERS	7:4	Proximity interrupt persistence. Controls rate of proximity interrupt to the host processor.							
		<b>FIELD VALUE</b>	<b>MEANING</b>	<b>INTERRUPT PERSISTENCE FUNCTION</b>					
		0000	---	Every proximity cycle generates an interrupt					
		0001	1	1 proximity value out of range					
		0010	2	2 consecutive proximity values out of range					
		... 1111	... 15	... 15 consecutive proximity values out of range					
APERS	3:0	Interrupt persistence. Controls rate of interrupt to the host processor.							
		<b>FIELD VALUE</b>	<b>MEANING</b>	<b>INTERRUPT PERSISTENCE FUNCTION</b>					
		0000	Every	Every ALS cycle generates an interrupt					
		0001	1	1 value outside of threshold range					
		0010	2	2 consecutive values out of range					
		0011	3	3 consecutive values out of range					
		0100	5	5 consecutive values out of range					
		0101	10	10 consecutive values out of range					
		0110	15	15 consecutive values out of range					
		0111	20	20 consecutive values out of range					
		1000	25	25 consecutive values out of range					
		1001	30	30 consecutive values out of range					
		1010	35	35 consecutive values out of range					
		1011	40	40 consecutive values out of range					
		1100	45	45 consecutive values out of range					
		1101	50	50 consecutive values out of range					
1110	55	55 consecutive values out of range							
1111	60	60 consecutive values out of range							

**TSL2771**  
**LIGHT-TO-DIGITAL CONVERTER**  
**with PROXIMITY SENSING**

TAOS100B – FEBRUARY 2011

**Configuration Register (0x0D)**

The configuration register sets the wait long time.

**Table 10. Configuration Register**

	7	6	5	4	3	2	1	0	
CONFIG	Reserved						WLONG	Reserved	Address 0x0D

FIELD	BITS	DESCRIPTION
Reserved	7:2	Reserved. Write as 0.
WLONG	1	Wait Long. When asserted, the wait cycles are increased by a factor 12X from that programmed in the WTIME register.
Reserved	0	Reserved. Write as 0.

**Proximity Pulse Count Register (0x0E)**

The proximity pulse count register sets the number of proximity pulses that will be transmitted. When proximity detection is enabled, a proximity detect cycle occurs after each ALS cycle. PPULSE defines the number of pulses to be transmitted at a 62.5-kHz rate.

**NOTE:** The ATIME register will be used to time the interval between proximity detection events even if the ALS function is disabled.

**Table 11. Proximity Pulse Count Register**

	7	6	5	4	3	2	1	0	
PPULSE	PPULSE								Address 0x0E

FIELD	BITS	DESCRIPTION
PPULSE	7:0	Proximity Pulse Count. Specifies the number of proximity pulses to be generated.

### Control Register (0x0F)

The Control register provides eight bits of miscellaneous control to the analog block. These bits typically control functions such as gain settings and/or diode selection.

**Table 12. Control Register**

	7	6	5	4	3	2	1	0	
<b>CONTROL</b>	<b>PDRIVE</b>		<b>PDIODE</b>		Reserved		<b>AGAIN</b>		<b>Address 0x0F</b>

FIELD	BITS	DESCRIPTION	
PDRIVE	7:6	LED Drive Strength.	
		<b>FIELD VALUE</b>	<b>LED STRENGTH</b>
		00	100 mA
		01	50 mA
		10	25 mA
		11	12.5 mA
PDIODE	5:4	Proximity Diode Select.	
		<b>FIELD VALUE</b>	<b>DIODE SELECTION</b>
		00	Reserved
		01	Proximity uses the CH0 diode
		10	Proximity uses the CH1 diode
		11	Proximity uses both diodes
Reserved	3:2	Reserved. Write bits as zero (0:0)	
AGAIN	1:0	ALS Gain Control.	
		<b>FIELD VALUE</b>	<b>ALS GAIN VALUE</b>
		00	1× gain
		01	8× gain
		10	16× gain
		11	120× gain

### ID Register (0x12)

The ID Register provides the value for the part number. The ID register is a read-only register.

**Table 13. ID Register**

	7	6	5	4	3	2	1	0	
<b>ID</b>	<b>ID</b>								<b>Address 0x12</b>

FIELD	BITS	DESCRIPTION	
ID	7:0	Part number identification	0x00 = TSL27711 & TSL27715
			0x09 = TSL27713 & TSL27717



# TSL2771 LIGHT-TO-DIGITAL CONVERTER with PROXIMITY SENSING

TAOS100B – FEBRUARY 2011

## Status Register (0x13)

The Status Register provides the internal status of the device. This register is read only.

**Table 14. Status Register**

	7	6	5	4	3	2	1	0	
STATUS	Reserved		PINT	AINT	Reserved		AVALID		Address 0x13

FIELD	BIT	DESCRIPTION
Reserved	7:6	Reserved.
PINT	5	Proximity Interrupt. Indicates that the device is asserting a proximity interrupt.
AINT	4	ALS Interrupt. Indicates that the device is asserting an ALS interrupt.
Reserved	3:1	Reserved.
AVALID	0	ALS Valid. Indicates that the ALS channels have completed an integration cycle.

## ADC Channel Data Registers (0x14 – 0x17)

ALS data is stored as two 16-bit values. To ensure the data is read correctly, a two-byte read I<sup>2</sup>C transaction should be used with auto increment protocol bits set in the command register. With this operation, when the lower byte register is read, the upper eight bits are stored in a shadow register, which is read by a subsequent read to the upper byte. The upper register will read the correct value even if additional ADC integration cycles end between the reading of the lower and upper registers.

**Table 15. ADC Channel Data Registers**

REGISTER	ADDRESS	BITS	DESCRIPTION
C0DATA	0x14	7:0	ALS CH0 data low byte
C0DATAH	0x15	7:0	ALS CH0 data high byte
C1DATA	0x16	7:0	ALS CH1 data low byte
C1DATAH	0x17	7:0	ALS CH1 data high byte

## Proximity Data Registers (0x18 – 0x19)

Proximity data is stored as a 16-bit value. To ensure the data is read correctly, a two-byte read I<sup>2</sup>C transaction should be utilized with auto increment protocol bits set in the command register. With this operation, when the lower byte register is read, the upper eight bits are stored into a shadow register, which is read by a subsequent read to the upper byte. The upper register will read the correct value even if the next ADC cycle ends between the reading of the lower and upper registers.

**Table 16. PDATA Registers**

REGISTER	ADDRESS	BITS	DESCRIPTION
PDATAH	0x18	7:0	Proximity data low byte
PDATAH	0x19	7:0	Proximity data high byte



**APPLICATION INFORMATION: HARDWARE**

**LED Driver Pin with Proximity Detection**

In a proximity sensing system, the IR LED can be pulsed by the TSL2771 with more than 100 mA of rapidly switching current, therefore, a few design considerations must be kept in mind to get the best performance. The key goal is to reduce the power supply noise coupled back into the device during the LED pulses.

The first recommendation is to use two power supplies; one for the device  $V_{DD}$  and the other for the IR LED. In many systems, there is a quiet analog supply and a noisy digital supply. By connecting the quiet supply to the  $V_{DD}$  pin and the noisy supply to the LED, the key goal can be met. Place a 1- $\mu\text{F}$  low-ESR decoupling capacitor as close as possible to the  $V_{DD}$  pin and another at the LED anode, and a 22- $\mu\text{F}$  capacitor at the output of the LED voltage regulator to supply the 100-mA current surge.

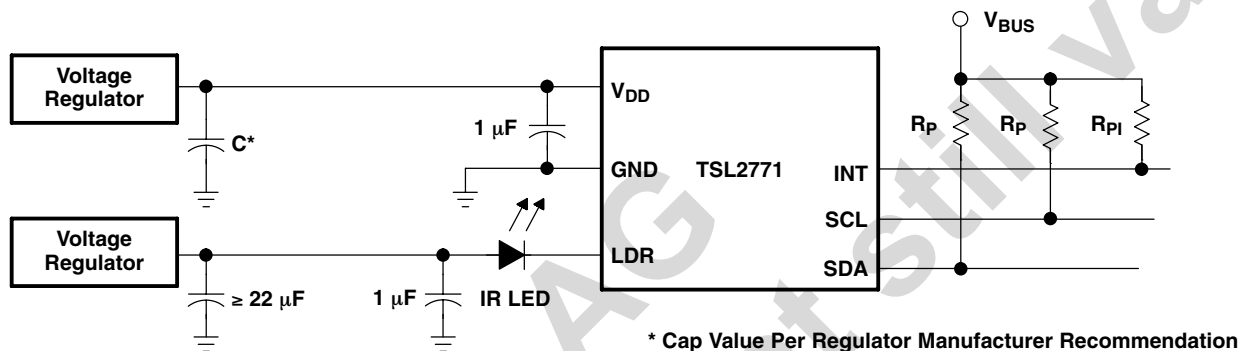

**Figure 16. Proximity Sensing Using Separate Power Supplies**

If it is not possible to provide two separate power supplies, the device can be operated from a single supply. A 22- $\Omega$  resistor in series with the  $V_{DD}$  supply line and a 1- $\mu\text{F}$  low ESR capacitor effectively filter any power supply noise. The previous capacitor placement considerations apply.

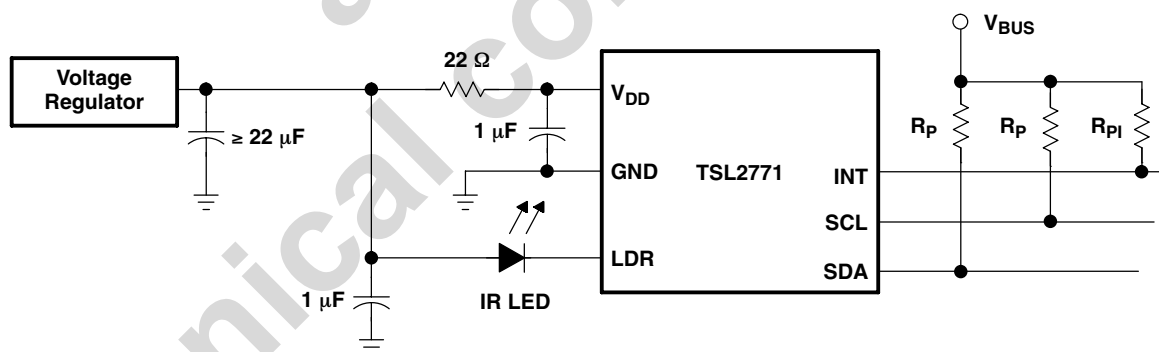

**Figure 17. Proximity Sensing Using Single Power Supply**

$V_{BUS}$  in the above figures refers to the I<sup>2</sup>C bus voltage which is either  $V_{DD}$  or 1.8 V. Be sure to apply the specified I<sup>2</sup>C bus voltage shown in the Available Options table for the specific device being used.

The I<sup>2</sup>C signals and the Interrupt are open-drain outputs and require pull-up resistors. The pull-up resistor ( $R_P$ ) value is a function of the I<sup>2</sup>C bus speed, the I<sup>2</sup>C bus voltage, and the capacitive load. The TAOS EVM running at 400 kbps, uses 1.5-k $\Omega$  resistors. A 10-k $\Omega$  pull-up resistor ( $R_{PI}$ ) can be used for the interrupt line.

**APPLICATION INFORMATION: HARDWARE**

**PCB Pad Layout**

Suggested PCB pad layout guidelines for the Dual Flat No-Lead (FN) surface mount package are shown in Figure 18.

Note: Pads can be extended further if hand soldering is needed.

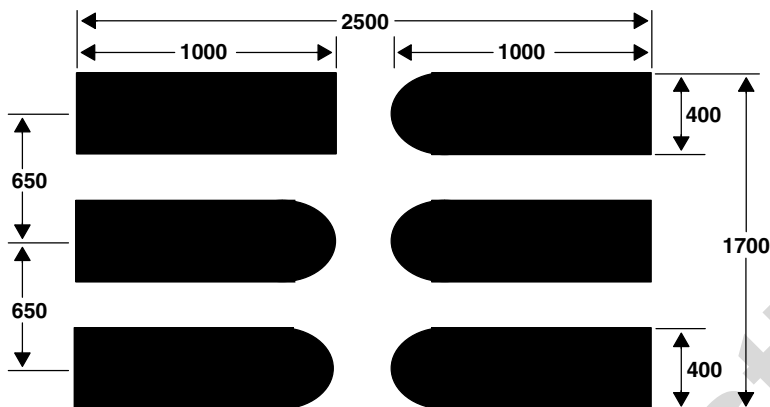

- NOTES: A. All linear dimensions are in micrometers.  
 B. This drawing is subject to change without notice.

**Figure 18. Suggested FN Package PCB Layout**

MECHANICAL DATA

PACKAGE FN

Dual Flat No-Lead

TOP VIEW

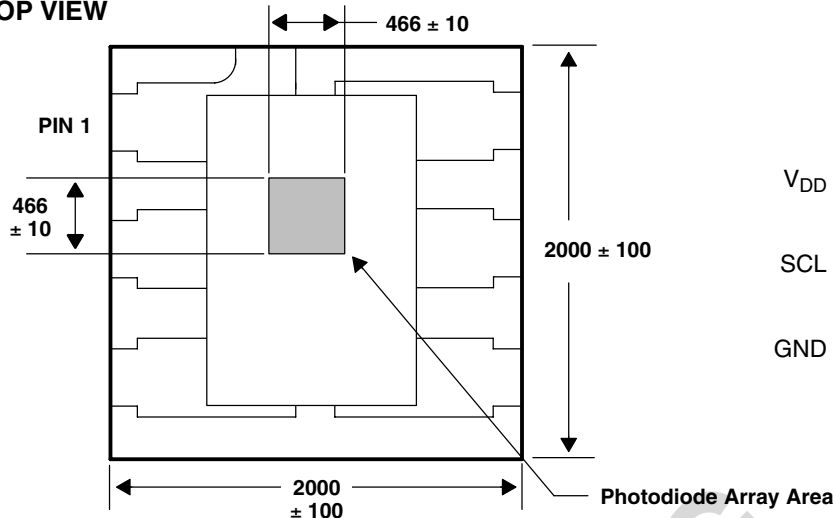

PIN OUT  
 TOP VIEW

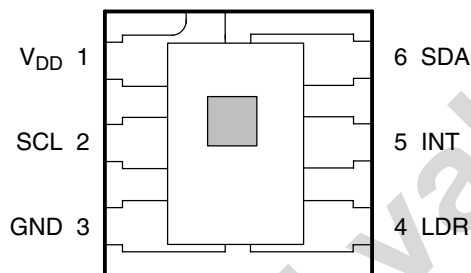

END VIEW

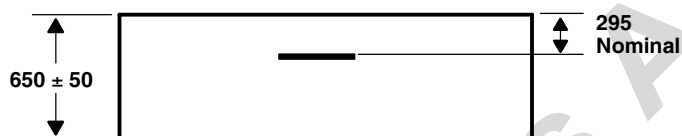

SIDE VIEW

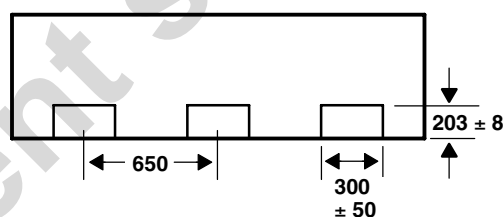

BOTTOM VIEW

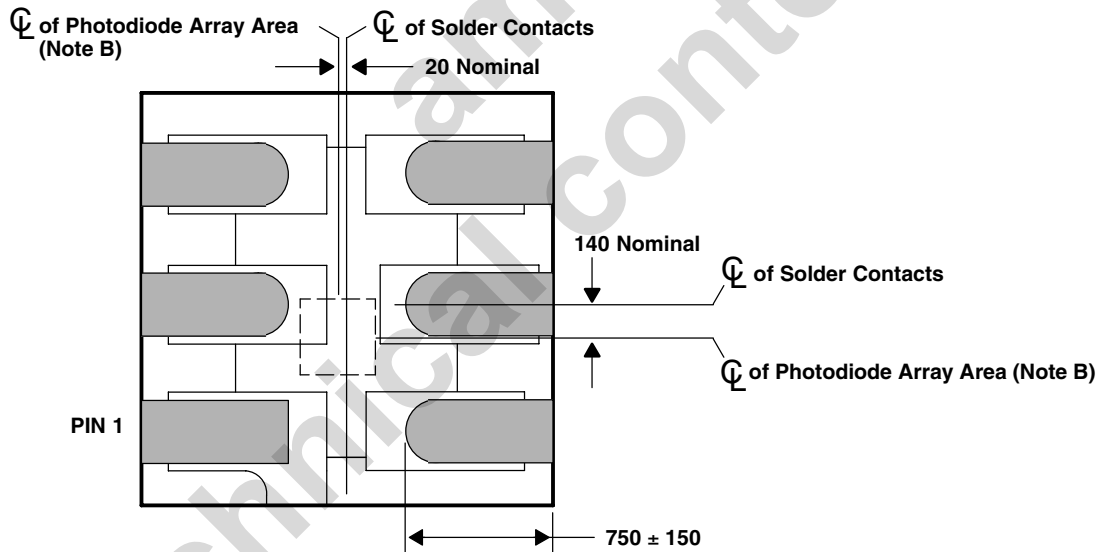

Lead Free

- NOTES: A. All linear dimensions are in micrometers. Dimension tolerance is  $\pm 20 \mu\text{m}$  unless otherwise noted.  
 B. The die is centered within the package within a tolerance of  $\pm 3$  mils.  
 C. Package top surface is molded with an electrically nonconductive clear plastic compound having an index of refraction of 1.55.  
 D. Contact finish is copper alloy A194 with pre-plated NiPdAu lead finish.  
 E. This package contains no lead (Pb).  
 F. This drawing is subject to change without notice.

Figure 19. Package FN — Dual Flat No-Lead Packaging Configuration

**TSL2771  
LIGHT-TO-DIGITAL CONVERTER  
with PROXIMITY SENSING**

TAOS100B – FEBRUARY 2011

**MECHANICAL DATA**

**TOP VIEW**

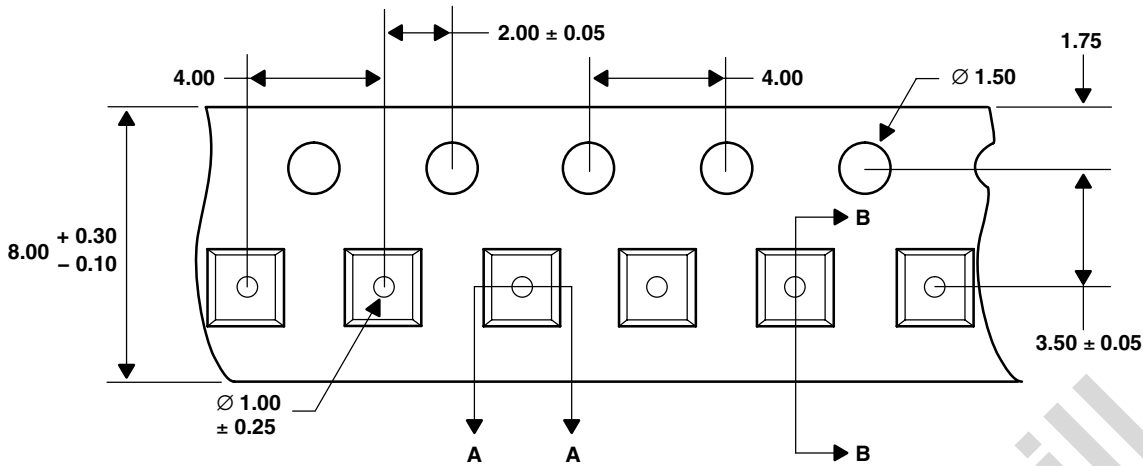

**DETAIL A**

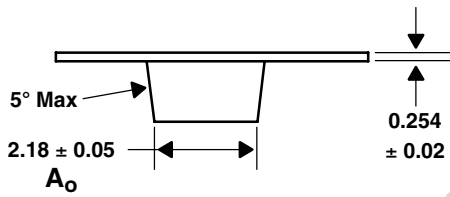

**DETAIL B**

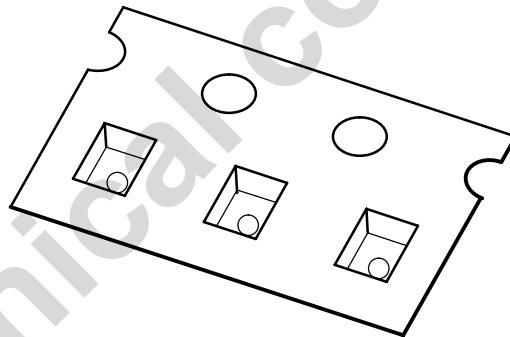
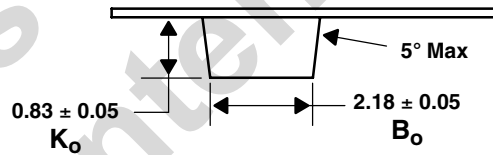

- NOTES: A. All linear dimensions are in millimeters. Dimension tolerance is  $\pm 0.10$  mm unless otherwise noted.  
 B. The dimensions on this drawing are for illustrative purposes only. Dimensions of an actual carrier may vary slightly.  
 C. Symbols on drawing  $A_o$ ,  $B_o$ , and  $K_o$  are defined in ANSI EIA Standard 481-B 2001.  
 D. Each reel is 178 millimeters in diameter and contains 3500 parts.  
 E. TAOS packaging tape and reel conform to the requirements of EIA Standard 481-B.  
 F. In accordance with EIA standard, device pin 1 is located next to the sprocket holes in the tape.  
 G. This drawing is subject to change without notice.

**Figure 20. Package FN Carrier Tape**

**MANUFACTURING INFORMATION**

The FN package has been tested and has demonstrated an ability to be reflow soldered to a PCB substrate.

The solder reflow profile describes the expected maximum heat exposure of components during the solder reflow process of product on a PCB. Temperature is measured on top of component. The components should be limited to a maximum of three passes through this solder reflow profile.

**Table 17. Solder Reflow Profile**

PARAMETER	REFERENCE	DEVICE
Average temperature gradient in preheating		2.5°C/sec
Soak time	$t_{soak}$	2 to 3 minutes
Time above 217°C (T1)	$t_1$	Max 60 sec
Time above 230°C (T2)	$t_2$	Max 50 sec
Time above $T_{peak} - 10^\circ\text{C}$ (T3)	$t_3$	Max 10 sec
Peak temperature in reflow	$T_{peak}$	260°C
Temperature gradient in cooling		Max -5°C/sec

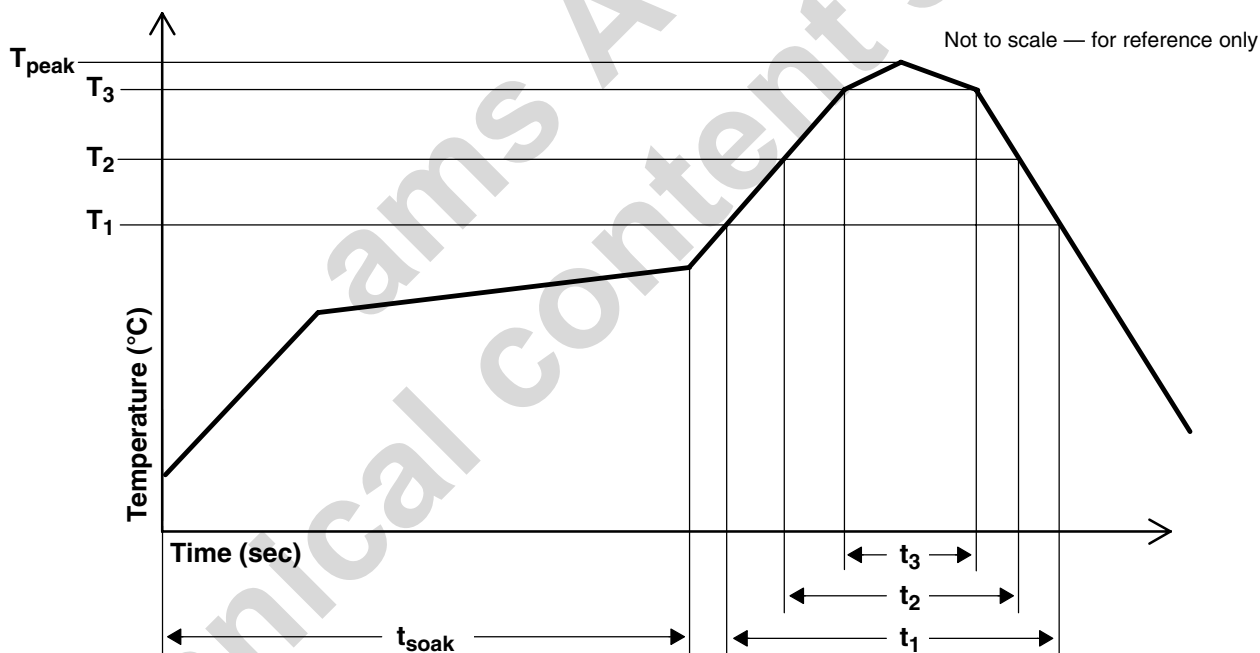

**Figure 21. Solder Reflow Profile Graph**

**TSL2771**  
**LIGHT-TO-DIGITAL CONVERTER**  
**with PROXIMITY SENSING**

TAOS100B – FEBRUARY 2011

---

**MANUFACTURING INFORMATION**

**Moisture Sensitivity**

Optical characteristics of the device can be adversely affected during the soldering process by the release and vaporization of moisture that has been previously absorbed into the package. To ensure the package contains the smallest amount of absorbed moisture possible, each device is dry-baked prior to being packed for shipping. Devices are packed in a sealed aluminized envelope called a moisture barrier bag with silica gel to protect them from ambient moisture during shipping, handling, and storage before use.

The FN package has been assigned a moisture sensitivity level of MSL 3 and the devices should be stored under the following conditions:

Temperature Range	5°C to 50°C
Relative Humidity	60% maximum
Total Time	12 months from the date code on the aluminized envelope — if unopened
Opened Time	168 hours or fewer

Rebaking will be required if the devices have been stored unopened for more than 12 months or if the aluminized envelope has been open for more than 168 hours. If rebaking is required, it should be done at 50°C for 12 hours.

ams AG  
Technical content still valid

**PRODUCTION DATA** — information in this document is current at publication date. Products conform to specifications in accordance with the terms of Texas Advanced Optoelectronic Solutions, Inc. standard warranty. Production processing does not necessarily include testing of all parameters.

### **LEAD-FREE (Pb-FREE) and GREEN STATEMENT**

**Pb-Free (RoHS)** TAOS' terms *Lead-Free* or *Pb-Free* mean semiconductor products that are compatible with the current RoHS requirements for all 6 substances, including the requirement that lead not exceed 0.1% by weight in homogeneous materials. Where designed to be soldered at high temperatures, TAOS Pb-Free products are suitable for use in specified lead-free processes.

**Green (RoHS & no Sb/Br)** TAOS defines *Green* to mean Pb-Free (RoHS compatible), and free of Bromine (Br) and Antimony (Sb) based flame retardants (Br or Sb do not exceed 0.1% by weight in homogeneous material).

**Important Information and Disclaimer** The information provided in this statement represents TAOS' knowledge and belief as of the date that it is provided. TAOS bases its knowledge and belief on information provided by third parties, and makes no representation or warranty as to the accuracy of such information. Efforts are underway to better integrate information from third parties. TAOS has taken and continues to take reasonable steps to provide representative and accurate information but may not have conducted destructive testing or chemical analysis on incoming materials and chemicals. TAOS and TAOS suppliers consider certain information to be proprietary, and thus CAS numbers and other limited information may not be available for release.

### **NOTICE**

Texas Advanced Optoelectronic Solutions, Inc. (TAOS) reserves the right to make changes to the products contained in this document to improve performance or for any other purpose, or to discontinue them without notice. Customers are advised to contact TAOS to obtain the latest product information before placing orders or designing TAOS products into systems.

TAOS assumes no responsibility for the use of any products or circuits described in this document or customer product design, conveys no license, either expressed or implied, under any patent or other right, and makes no representation that the circuits are free of patent infringement. TAOS further makes no claim as to the suitability of its products for any particular purpose, nor does TAOS assume any liability arising out of the use of any product or circuit, and specifically disclaims any and all liability, including without limitation consequential or incidental damages.

TEXAS ADVANCED OPTOELECTRONIC SOLUTIONS, INC. PRODUCTS ARE NOT DESIGNED OR INTENDED FOR USE IN CRITICAL APPLICATIONS IN WHICH THE FAILURE OR MALFUNCTION OF THE TAOS PRODUCT MAY RESULT IN PERSONAL INJURY OR DEATH. USE OF TAOS PRODUCTS IN LIFE SUPPORT SYSTEMS IS EXPRESSLY UNAUTHORIZED AND ANY SUCH USE BY A CUSTOMER IS COMPLETELY AT THE CUSTOMER'S RISK.

LUMENOLOGY, TAOS, the TAOS logo, and Texas Advanced Optoelectronic Solutions are registered trademarks of Texas Advanced Optoelectronic Solutions Incorporated.

ams AG  
Technical content still valid