

High bandwidth 8 MHz, rail-to-rail, 5 V cost-effective op amp



TSL6201



TSL6202



TSL6204

Features

- Automotive grade version available 
- Gain bandwidth product 8 MHz, unity gain stable
- Rail-to-rail input and output
- Wide supply voltage range: 2.5 V to 5.5 V
- Input offset voltage: 4.5 mV
- Low input bias current: 1 pA typ.
- Extended temperature range: -40 °C to +125 °C

Applications

- Cost-sensitive applications
- Battery-powered products
- Automotive applications

Description

The TSL6201, TSL6202 and the TSL6204 are single, dual and quad 8 MHz bandwidth unity-gain-stable amplifiers. The rail-to-rail input stage and the wide supply range from 2.5 V to 5.5 V make the TSL620x ideal for low voltage signal conditioning.

Product status link

SOT23-5	TSL6201
MiniSO8	TSL6202
TSSOP14	TSL6204

Related products

For more power savings	TSL6001
------------------------	-------------------------

1 Pin description

1.1 TSL6201 single operational amplifier

Figure 1. SOT23-5 pin connections (top view)

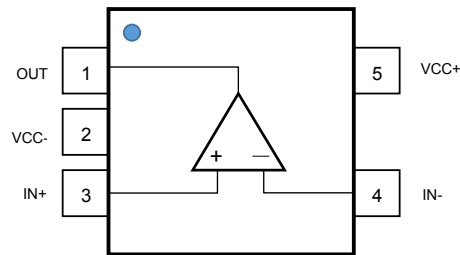

Table 1. SOT23-5 pin description

Pin	Pin name	Description
1	OUT	Output
2	VCC-	Negative supply voltage
3	IN+	Non-inverting input
4	IN-	Inverting input
5	VCC+	Positive supply voltage

1.2 TSL6202 dual operational amplifier

Figure 2. MiniSO8 pin connection (top view)

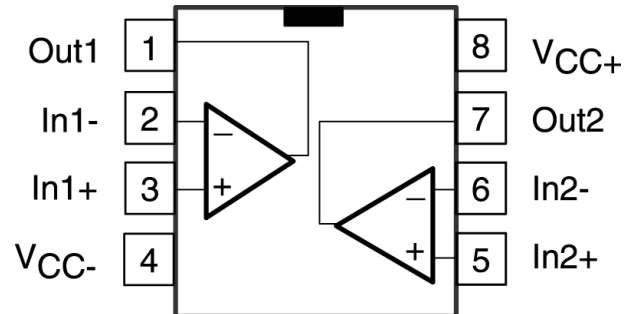

Table 2. MiniSO8 pin description

Pin	Pin name	Description
1	OUT1	Output channel 1
2	IN1-	Inverting input channel 1
3	IN1+	Non-inverting input channel 1
4	VCC-	Negative supply voltage
5	IN2+	Non-inverting input channel 2
6	IN2-	Inverting input channel 2
7	OUT2	Output channel 2
8	VCC+	Positive supply voltage

1.3 TSL6204 quad operational amplifier

Figure 3. TSSOP-14 pin connections (top view)

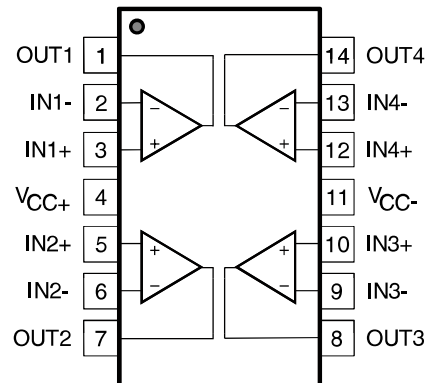

Table 3. TSSOP-14 pin description

Pin	Pin name	Description
1	OUT1	Output channel 1
2	IN1-	Inverting input channel 1
3	IN1+	Non-inverting input channel 1
4	VCC+	Positive supply voltage
5	IN2+	Non-inverting input channel 2
6	IN2-	Inverting input channel 2
7	OUT2	Output channel 2
8	OUT3	Output channel 3
9	IN3-	Inverting input channel 3
10	IN3+	Non-inverting input channel 3
11	VCC-	Negative supply voltage
12	IN4+	Non-inverting input channel 4
13	IN4-	Inverting input channel 4
14	OUT4	Output channel 4

2 Absolute maximum ratings

Table 4. Absolute maximum ratings

Symbol	Parameter	Value	Unit
$V_{CC}^{(1)}$	Supply voltage	6	V
V_{id}	Input voltage differential ($V_{IN+} - V_{IN-}$)	$\pm V_{CC}$	V
$V_{in}^{(2)}$	Input voltage	$(V_{CC-}) - 0.2$ to $(V_{CC+}) + 0.2$	V
I_{in}	Input current	± 10	mA
T_{stg}	Storage temperature	-65 to +150	°C
$R_{th-ja}^{(3)}$	Thermal resistance junction-to-ambient		°C/W
	SOT23-5	250	
	MiniSO8	190	
	TSSOP-14	100	
T_j	Maximum junction temperature	150	°C
ESD	HBM: human body model ⁽⁴⁾	2	kV
	CDM: charged device model ⁽⁵⁾	0.5	kV

1. All voltage values are with respect to the VCC- pin, unless otherwise specified.
2. The maximum input voltage value may be extended to the condition that the input current is limited to ± 10 mA.
3. R_{th-ja} is a typical value.
4. Human body model: HBM test according to the standard ESDA/JEDEC JS-001-2017.
5. Charged device model: the test CDM is done in according to the standard ESDA/JEDEC JS-002-2018.

Table 5. Operating conditions

Symbol	Parameter	Value
V_{CC}	Supply voltage	2.5 to 5.5 V
V_{icm}	Common mode input voltage range (CMR)	$V_{CC-} - 0.1$ V to $V_{CC+} + 0.1$ V
T_{oper}	Operating free air temperature range	-40 °C to +125 °C

3 Electrical characteristics

Table 6. Electrical characteristics at $V_{CC} = 2.5\text{ V to }5.5\text{ V}$, $V_{ICM} = V_{OUT} = V_{CC} / 2$, $T = 25\text{ °C}$ and OUT connected to $V_{CC} / 2$ through $R_L = 10\text{ k}\Omega$ (unless otherwise specified)

Symbol	Parameter	Conditions	Min.	Typ.	Max.	Unit
DC performance						
V_{io}	Input offset voltage	$T = 25\text{ °C}$			± 4.5	mV
		$-40\text{ °C} \leq T \leq 125\text{ °C}$			± 7.5	
DV_{io}/DT	Input offset voltage temperature drift	$-40\text{ °C} \leq T \leq 125\text{ °C}$		± 5		$\mu\text{V}/\text{°C}$
I_{ib}	Input bias current			± 1		pA
I_{io}	Input offset current			± 1		pA
A_{VD}	Open loop gain	$V_{CC-} + 500\text{ mV} \leq V_{OUT} \leq V_{CC+} - 500\text{ mV}$	80	89		dB
CMR	Common-mode rejection ratio $20 \cdot \log(\Delta V_{io} / \Delta V_{icm})$	$V_{CC-} \leq V_{icm} \leq V_{CC+}$	58	78		dB
V_{OH}	High level output voltage drop ($V_{OH} = V_{CC+} - V_{OUT}$)				40	mV
V_{OL}	Low level output voltage drop ($V_{OL} = V_{OUT}$)				40	mV
I_{OUT}	Short-circuit	$V_{CC} = 5\text{ V}$		± 30		mA
I_{CC}	Supply current (by operational amplifier)	No load		750	1400	μA
AC performance						
GBP	Gain bandwidth product	$R_L = 2\text{ k}\Omega$, $C_L = 100\text{ pF}$, $f = 100\text{ kHz}$		8		MHz
SR	Slew rate	$A_V = 1\text{ V/V}$, 10% to 90%		4.5		$\text{V}/\mu\text{s}$
Φ_m	Phase margin	$R_L = 2\text{ k}\Omega$, $C_L = 100\text{ pF}$		45		Degrees
en	Input voltage noise density	$f = 10\text{ kHz}$		21		$\text{nV}/\sqrt{\text{Hz}}$

4 Typical performance characteristics

Figure 4. Input offset voltage vs. common mode voltage

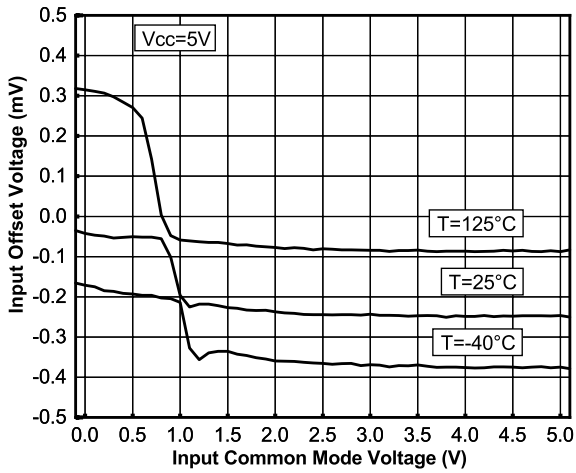

Figure 5. Positive slew rate vs. supply voltage

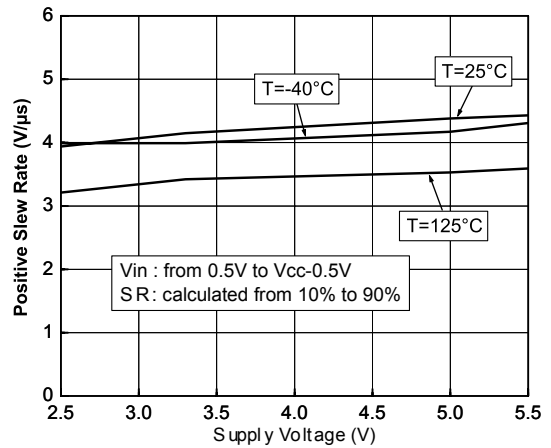

Figure 6. Negative slew rate vs. supply voltage

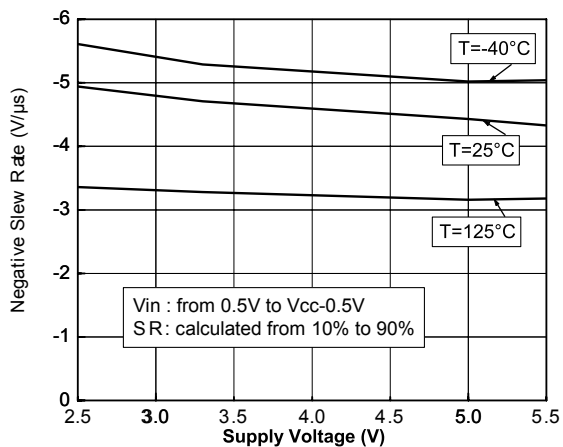

Figure 7. Input equivalent noise vs. frequency

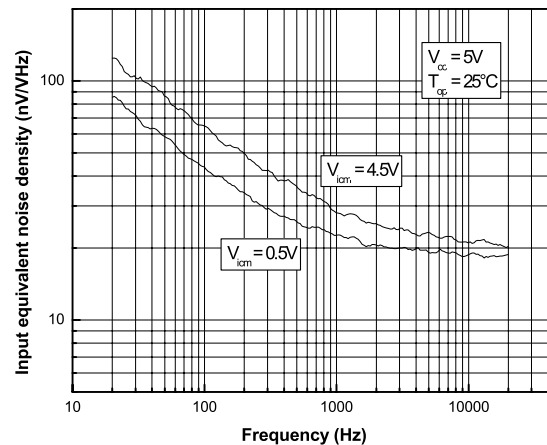

Figure 8. Output current vs. output voltage

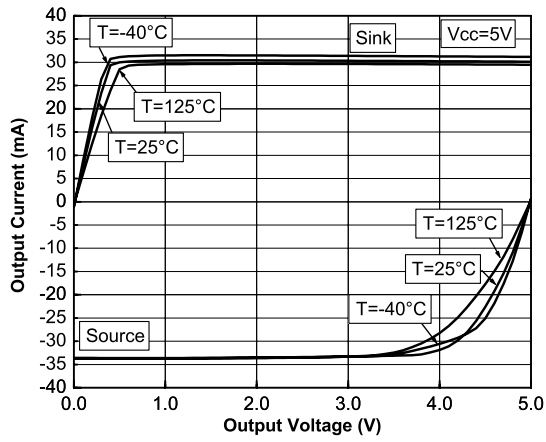

Figure 9. Supply current vs. input common voltage

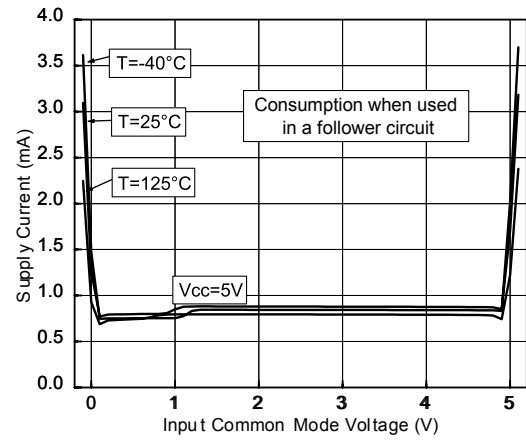

Figure 10. Supply current vs. input common mode voltage

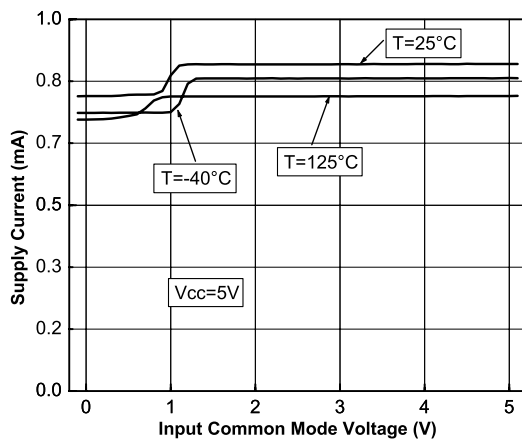
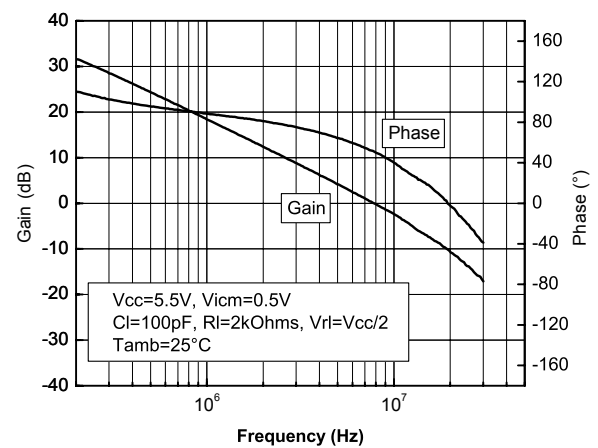

Figure 11. Bode diagram



5 Package information

In order to meet environmental requirements, ST offers these devices in different grades of **ECOPACK** packages, depending on their level of environmental compliance. ECOPACK specifications, grade definitions and product status are available at: www.st.com. ECOPACK is an ST trademark.

5.1 SOT23-5 package information

Figure 12. SOT23-5 package outline

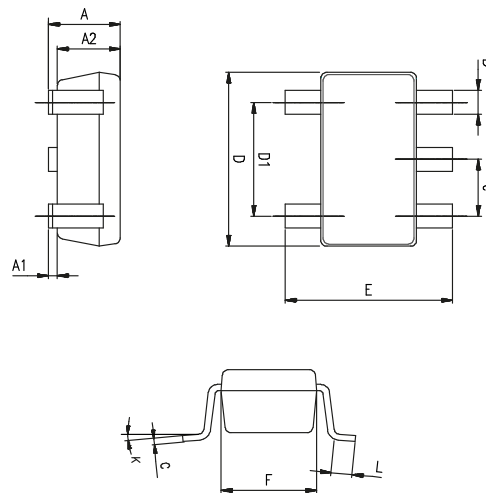

Table 7. SOT23-5 package mechanical data

Ref.	Dimensions					
	Millimeters			Inches		
	Min.	Typ.	Max.	Min.	Typ.	Max.
A	0.90	1.20	1.45	0.035	0.047	0.057
A1			0.15			0.006
A2	0.90	1.05	1.30	0.035	0.041	0.051
B	0.35	0.40	0.50	0.014	0.016	0.020
C	0.09	0.15	0.20	0.004	0.006	0.020
D	2.80	2.90	3.00	0.110	0.114	0.118
D1		1.90			0.075	
e		0.95			0.037	
E	2.60	2.80	3.00	0.102	0.110	0.118
F	1.50	1.60	1.75	0.059	0.063	0.069
L	0.10	0.35	0.60	0.004	0.014	0.024
K	0°		10°	0°		10°

5.2 MiniSO8 package information

Figure 13. MiniSO8 package outline

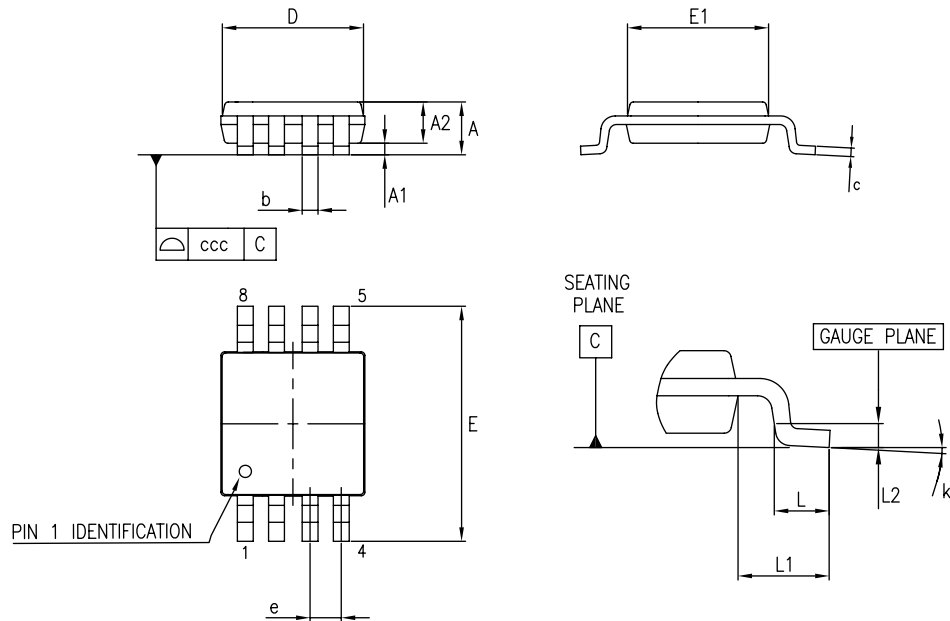

Table 8. MiniSO8 mechanical data

Dim.	Millimeters			Inches		
	Min.	Typ.	Max.	Min.	Typ.	Max.
A			1.1			0.043
A1	0		0.15	0		0.006
A2	0.75	0.85	0.95	0.03	0.033	0.037
b	0.22		0.4	0.009		0.016
c	0.08		0.23	0.003		0.009
D	2.8	3	3.2	0.11	0.118	0.126
E	4.65	4.9	5.15	0.183	0.193	0.203
E1	2.8	3	3.1	0.11	0.118	0.122
e		0.65			0.026	
L	0.4	0.6	0.8	0.016	0.024	0.031
L1		0.95			0.037	
L2		0.25			0.01	
k	0°		8°	0°		8°
ccc			0.1			0.004

5.3 TSSOP-14 package information

Figure 14. TSSOP-14 package outline

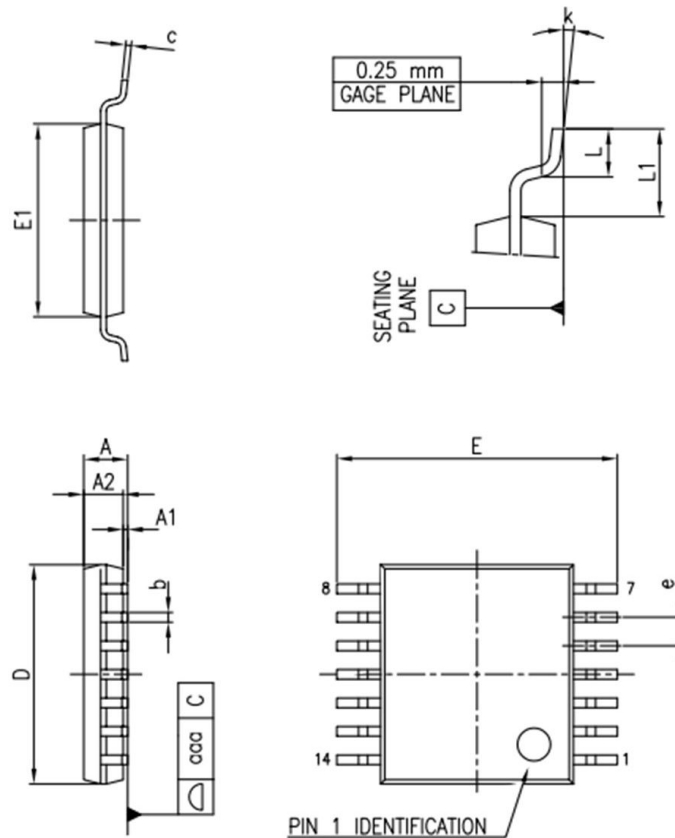

Table 9. TSSOP-14 mechanical data

Dim.	mm		
	Min.	Typ.	Max.
A			1.20
A1	0.05		0.15
A2	0.80	1.00	1.05
b	0.19		0.30
c	0.09		0.20
D	4.90	5.00	5.10
E	6.20	6.40	6.60
E1	4.30	4.40	4.50
e	0.65 BSC		
L	0.45	0.60	0.75
L1		1.00	
k	0		8
aaa			0.10

6 Ordering information

Table 10. Order code

Order code	Temperature range	Package	Marking
TSL6201ILT	-40 °C to 125 °C	SOT23-5	KD
TSL6201IYLT ⁽¹⁾	-40 °C to 125 °C automotive grade		KG
TSL6202IST	-40 °C to 125 °C	MiniSO8	KE
TSL6202IYST ⁽¹⁾	-40 °C to 125 °C automotive grade		KJ
TSL6204IPT	-40 °C to 125 °C	TSSOP-14	6204I
TSL6204IYPT ⁽¹⁾	-40 °C to 125 °C automotive grade		6204IY

1. Qualified and characterized according to AEC Q100 and Q003 or equivalent, advanced screening according to AEC Q001 & Q002 or equivalent. For qualification status detail, check "Maturity status link" on first page ("Quality & Reliability" tab on www.st.com).

Revision history

Table 11. Document revision history

Date	Version	Changes
01-Dec-2021	1	Initial release.
09-Jan-2023	2	Updated features, applications on the cover page and Section 6: Ordering information .
08-Feb-2024	3	Updated title, features and description on the cover page. Updated GBP value in Table 6 .

Contents

1	Pin description	2
1.1	TSL6201 single operational amplifier	2
1.2	TSL6202 dual operational amplifier	3
1.3	TSL6204 quad operational amplifier	4
2	Absolute maximum ratings	5
3	Electrical characteristics	6
4	Typical performance characteristics	7
5	Package information	9
5.1	SOT23-5 package information	9
5.2	MiniSO8 package information	10
5.3	TSSOP-14 package information	11
6	Ordering information	12
	Revision history	13

List of tables

Table 1.	SOT23-5 pin description	2
Table 2.	MiniSO8 pin description	3
Table 3.	TSSOP-14 pin description	4
Table 4.	Absolute maximum ratings	5
Table 5.	Operating conditions	5
Table 6.	Electrical characteristics at $V_{CC} = 2.5\text{ V to }5.5\text{ V}$, $V_{ICM} = V_{OUT} = V_{CC} / 2$, $T = 25\text{ }^{\circ}\text{C}$ and OUT connected to $V_{CC} / 2$ through $R_L = 10\text{ k}\Omega$ (unless otherwise specified)	6
Table 7.	SOT23-5 package mechanical data	9
Table 8.	MiniSO8 mechanical data	10
Table 9.	TSSOP-14 mechanical data	11
Table 10.	Order code	12
Table 11.	Document revision history	13

List of figures

Figure 1.	SOT23-5 pin connections (top view)	2
Figure 2.	MiniSO8 pin connection (top view)	3
Figure 3.	TSSOP-14 pin connections (top view)	4
Figure 4.	Input offset voltage vs. common mode voltage	7
Figure 5.	Positive slew rate vs. supply voltage	7
Figure 6.	Negative slew rate vs. supply voltage	7
Figure 7.	Input equivalent noise vs. frequency	7
Figure 8.	Output current vs. output voltage	8
Figure 9.	Supply current vs. input common voltage	8
Figure 10.	Supply current vs. input common mode voltage	8
Figure 11.	Bode diagram	8
Figure 12.	SOT23-5 package outline	9
Figure 13.	MiniSO8 package outline	10
Figure 14.	TSSOP-14 package outline	11

IMPORTANT NOTICE – READ CAREFULLY

STMicroelectronics NV and its subsidiaries (“ST”) reserve the right to make changes, corrections, enhancements, modifications, and improvements to ST products and/or to this document at any time without notice. Purchasers should obtain the latest relevant information on ST products before placing orders. ST products are sold pursuant to ST’s terms and conditions of sale in place at the time of order acknowledgment.

Purchasers are solely responsible for the choice, selection, and use of ST products and ST assumes no liability for application assistance or the design of purchasers’ products.

No license, express or implied, to any intellectual property right is granted by ST herein.

Resale of ST products with provisions different from the information set forth herein shall void any warranty granted by ST for such product.

ST and the ST logo are trademarks of ST. For additional information about ST trademarks, refer to www.st.com/trademarks. All other product or service names are the property of their respective owners.

Information in this document supersedes and replaces information previously supplied in any prior versions of this document.

© 2024 STMicroelectronics – All rights reserved