

## Nanopower 600 nA, rail-to-rail, 5 V cost-effective op amp



TSL6801



TSL6801



TSL6802



TSL6804

### Features

- Supply current 600 nA typ.
- Low supply voltage: 1.5 V - 5.5 V
- Unity gain stable
- Rail-to-rail input and output
- Gain bandwidth product: 8 kHz typ.
- Low input bias current: 5 pA max. at 25 °C
- Industrial temperature range: -40 °C to 85 °C

### Applications

- Cost-sensitive applications
- Battery-powered products

### Description

The TSL6801, TSL6802 and the TSL6804 are single, dual and quad 8 kHz-bandwidth unity-gain-stable amplifiers. The rail-to-rail input stage and the wide supply range from 2.5 V to 5.5 V make the TSL680x ideal for low voltage signal conditioning.

#### Product status link

SC70-5	<a href="#">TSL6801</a>
SOT23-5	<a href="#">TSL6801</a>
MiniSO8	<a href="#">TSL6802</a>
TSSOP14	<a href="#">TSL6804</a>

#### Related products

For higher bandwidth (1 MHz)	<a href="#">TSL6001</a>
For higher bandwidth (10 MHz)	<a href="#">TSL6201</a>

# 1 Pin description

## 1.1 TSL6801 single operational amplifier

Figure 1. SC70-5 and SOT23-5 pin connections (top view) for the TSL6801

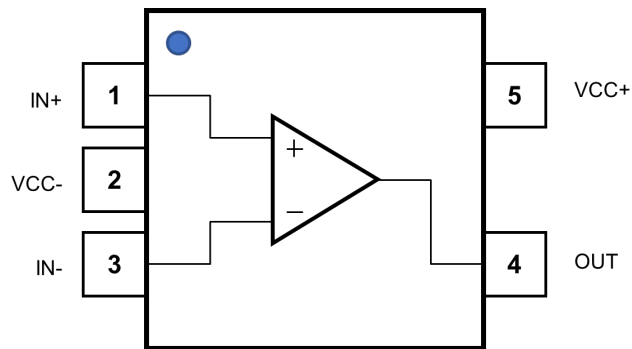

Figure 2. SC70-5 and SOT23-5 pin connections (top view) for the TSL6801R

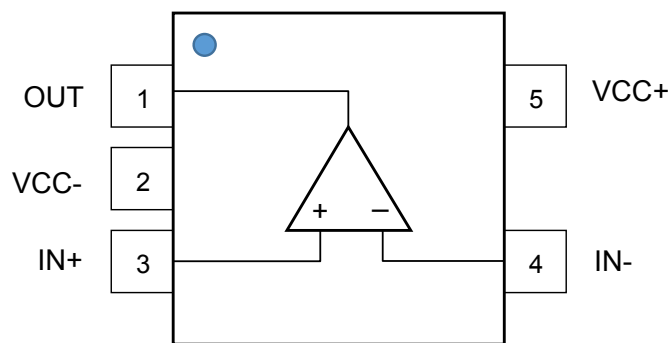

Table 1. SC70-5 and SOT23-5 pin description for the TSL6801 and the TSL6801R

Pin n. for the TSL6801	Pin n. for the TSL6801R	Pin name	Description
1	3	IN+	Non-inverting input channel
2	2	VCC-	Negative supply voltage
3	4	IN-	Inverting input channel
4	1	OUT	Output channel
5	5	VCC+	Positive supply voltage

## 1.2 TSL6802 dual operational amplifier

Figure 3. MiniSO8 pin connection (top view)

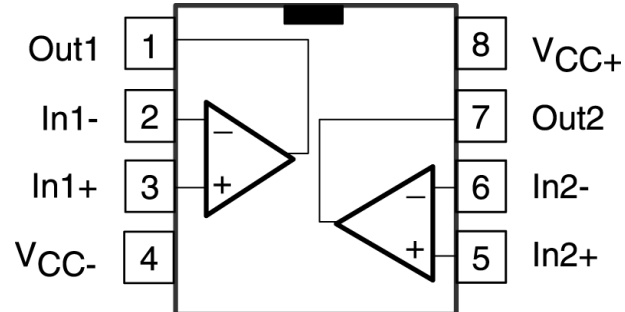

Table 2. MiniSO8 pin description

Pin	Pin name	Description
1	OUT1	Output channel 1
2	IN1-	Inverting input channel 1
3	IN1+	Non-inverting input channel 1
4	VCC-	Negative supply voltage
5	IN2+	Non-inverting input channel 2
6	IN2-	Inverting input channel 2
7	OUT2	Output channel 2
8	VCC+	Positive supply voltage

### 1.3 TSL6804 quad operational amplifier

Figure 4. TSSOP-14 pin connections (top view)

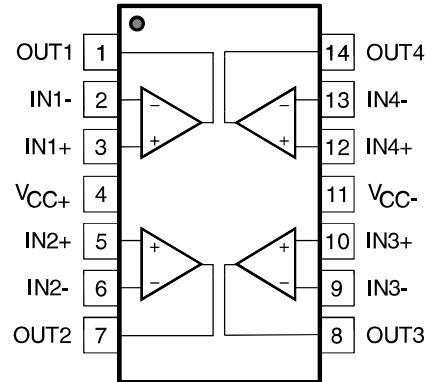

Table 3. TSSOP-14 pin description

Pin	Pin name	Description
1	OUT1	Output channel 1
2	IN1-	Inverting input channel 1
3	IN1+	Non-inverting input channel 1
4	VCC+	Positive supply voltage
5	IN2+	Non-inverting input channel 2
6	IN2-	Inverting input channel 2
7	OUT2	Output channel 2
8	OUT3	Output channel 3
9	IN3-	Inverting input channel 3
10	IN3+	Non-inverting input channel 3
11	VCC-	Negative supply voltage
12	IN4+	Non-inverting input channel 4
13	IN4-	Inverting input channel 4
14	OUT4	Output channel 4

## 2 Absolute maximum ratings

**Table 4. Absolute maximum ratings**

Symbol	Parameter <sup>(1)</sup>	Value	Unit
$V_{CC}^{(1)}$	Supply voltage	6	V
$V_{id}$	Input voltage differential ( $V_{IN+} - V_{IN-}$ )	$\pm V_{CC}$	V
$V_{in}^{(2)}$	Input voltage	$(V_{CC-}) - 0.2$ to $(V_{CC+}) + 0.2$	V
$I_{in}$	Input current	$\pm 10$	mA
$T_{stg}$	Storage temperature	-65 to +150	°C
$R_{th-ja}^{(3)}$	Thermal resistance junction-to-ambient		°C/W
	SOT23-5	250	
	MiniSO8	190	
	SC70-5	205	
	TSSOP-14	100	
$T_j$	Maximum junction temperature	150	°C
ESD	HBM: human body model <sup>(4)</sup>	2	kV
	CDM: charged device model <sup>(5)</sup>	0.9	kV

1. All voltage values are with respect to the VCC- pin, unless otherwise specified.
2. The maximum input voltage value may be extended to the condition that the input current is limited to  $\pm 10$  mA.
3.  $R_{th-ja}$  is a typical value.
4. Human body model: HBM test according to the standard ESDA/JEDEC JS-001-2017.
5. Charged device model: the test CDM is done in according to the standard ESDA/JEDEC JS-002-2018.

**Table 5. Operating conditions**

Symbol	Parameter	Value
$V_{CC}$	Supply voltage	1.5 to 5.5 V
$V_{icm}$	Common mode input voltage range (CMR)	$V_{CC-} - 0.1$ V to $V_{CC+} + 0.1$ V
$T_{oper}$	Operating free air temperature range	-40 °C to +85 °C

### 3 Electrical characteristics

**Table 6. Electrical characteristics at  $V_{CC} = 1.8\text{ V}$  to  $5.5\text{ V}$ ,  $V_{ICM} = V_{OUT} = V_{CC} / 2$ ,  $T = 25\text{ °C}$  and OUT connected to  $V_{CC} / 2$  through  $R_L = 10\text{ k}\Omega$  (unless otherwise specified)**

Symbol	Parameter	Conditions	Min.	Typ.	Max.	Unit
<b>DC performance</b>						
$V_{io}$	Input offset voltage			$\pm 0.1$	$\pm 3$	mV
$\Delta V_{io}/DT$	Input offset voltage temperature drift	$-40\text{ °C} \leq T \leq 85\text{ °C}$		$\pm 2$		$\mu\text{V}/\text{°C}$
$I_{ib}$	Input bias current			$\pm 1$		pA
$I_{io}$	Input offset current			$\pm 1$		pA
$A_{VD}$	Open loop gain	$V_{CC-} + 300\text{ mV} \leq V_{OUT} \leq V_{CC+} - 300\text{ mV}$ , $R_L = 100\text{ k}\Omega$	95	115		dB
CMR	Common-mode rejection ratio $20 \cdot \log(\Delta V_{io}/\Delta V_{icm})$	$V_{CC-} \leq V_{icm} \leq V_{CC+}$	60	80		dB
$V_{OH}$	High level output voltage drop ( $V_{OH} = V_{CC+} - V_{OUT}$ )				40	mV
$V_{OL}$	Low level output voltage drop ( $V_{OL} = V_{OUT}$ )				40	mV
$I_{OUT}$	Short-circuit current	$V_{CC+} = 1.8\text{ V}$		$\pm 5$		mA
		$V_{CC+} = 5\text{ V}$		$\pm 10$		
$I_{CC}$	Supply current (by operational amplifier)			0.6	1	$\mu\text{A}$
<b>AC performance</b>						
GBP	Gain bandwidth product	$C_L = 60\text{ pF}$		8		kHz
SR	Slew rate	$C_L = 60\text{ pF}$ , $A_V = 1\text{ V/V}$ , 10% to 90%		3		V/ms
$\Phi_m$	Phase margin	$C_L = 60\text{ pF}$		50		Degrees
$e_n$	Input voltage noise density	$f = 100\text{ kHz}$		240		$\text{nV}/\sqrt{\text{Hz}}$
		$f = 1\text{ kHz}$		225		
$e_n\text{ p-p}$	Input noise voltage	$0.1\text{ Hz} \leq f \leq 10\text{ Hz}$		8		$\mu\text{V}_{pp}$

## 4 Typical performance characteristics

Figure 5. Supply current vs. supply voltage

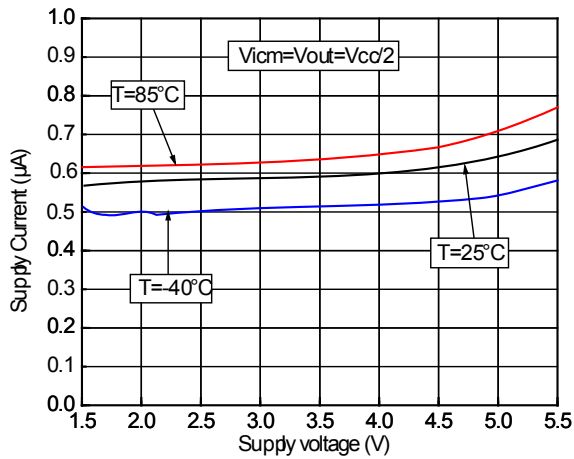

Figure 6. Input offset voltage distribution

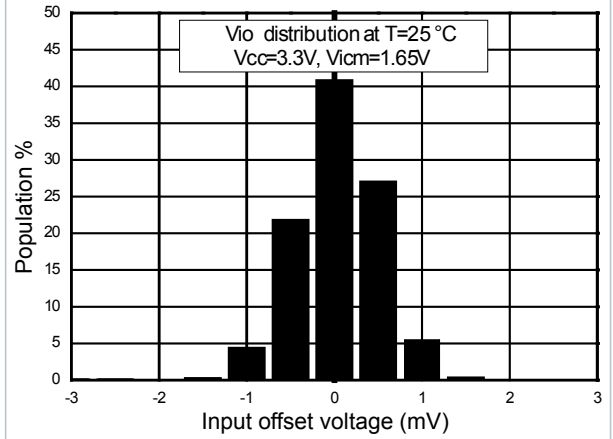

Figure 7. Input offset voltage vs. common mode voltage

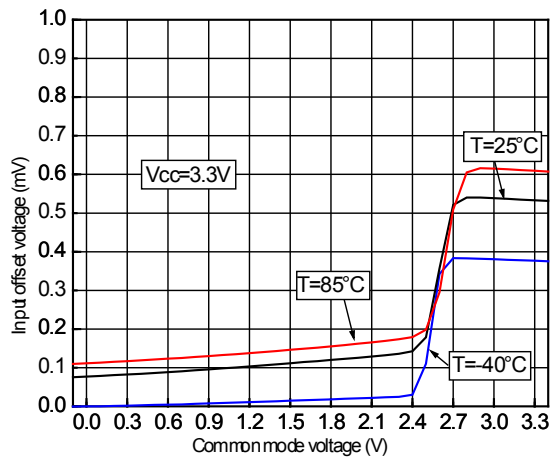
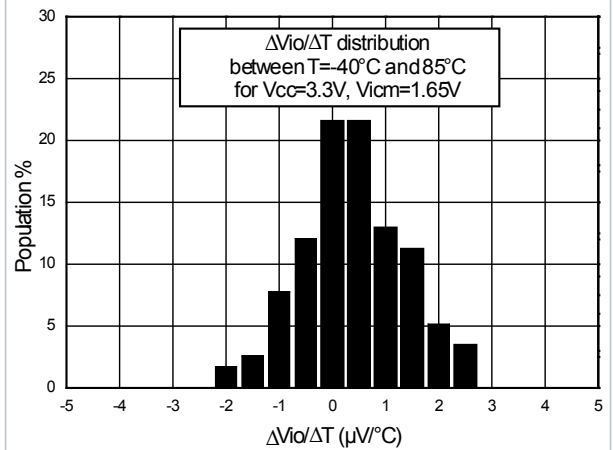
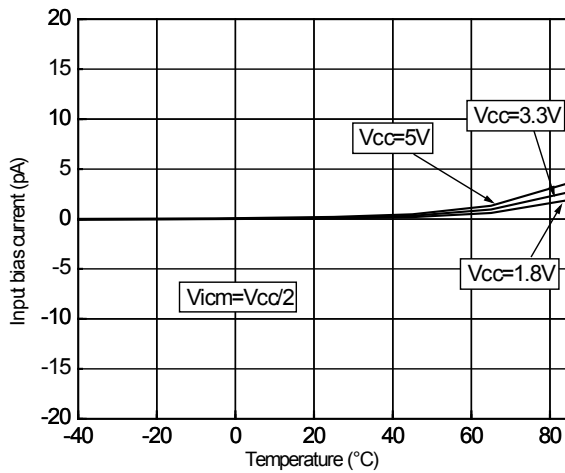
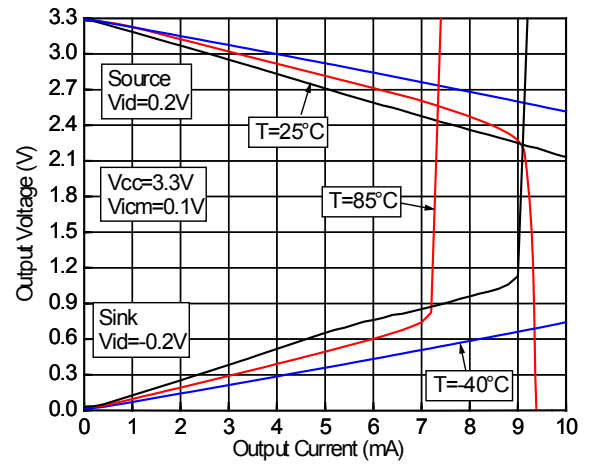
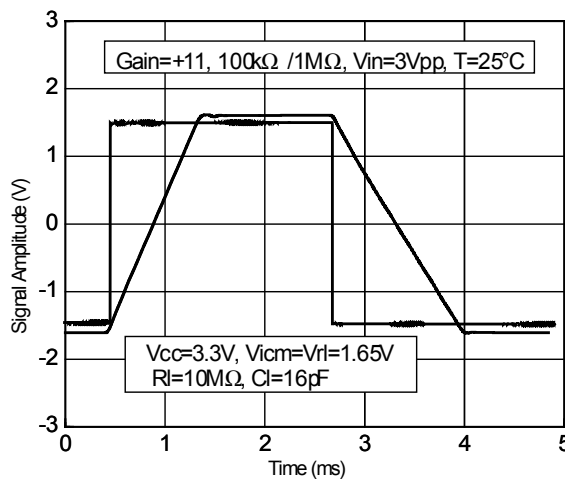
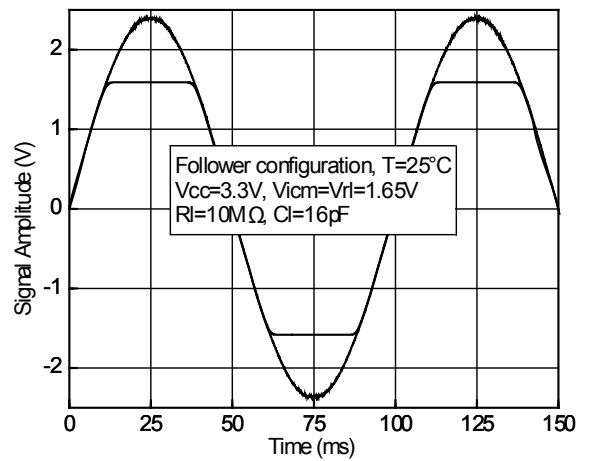
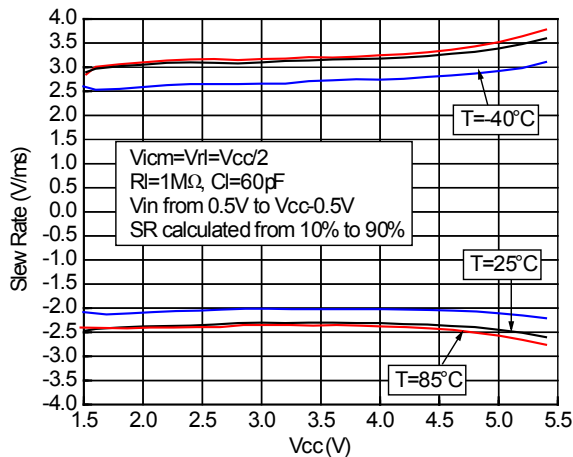
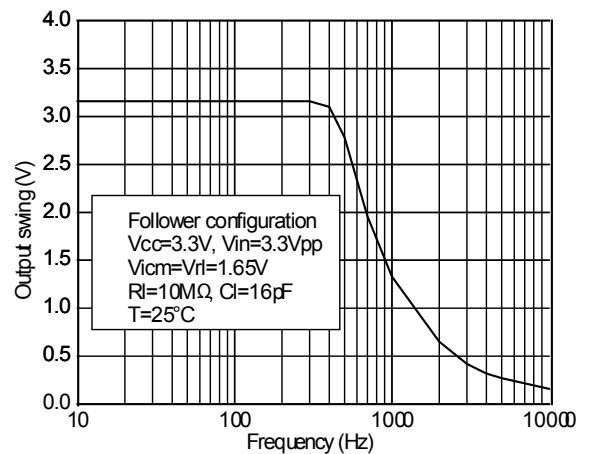

Figure 8. Input offset voltage temperature coefficient distribution



**Figure 9. Input bias current vs. temperature**

**Figure 10. Output characteristics at 3.3 V supply voltage**

**Figure 11. Desaturation time**

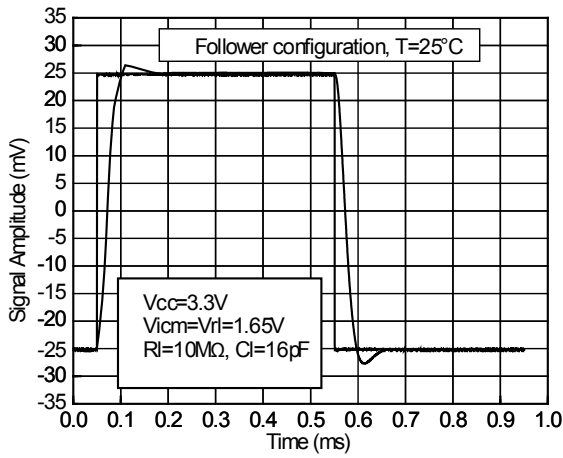
**Figure 12. Phase reversal free**

**Figure 13. Slew rate vs. supply voltage**

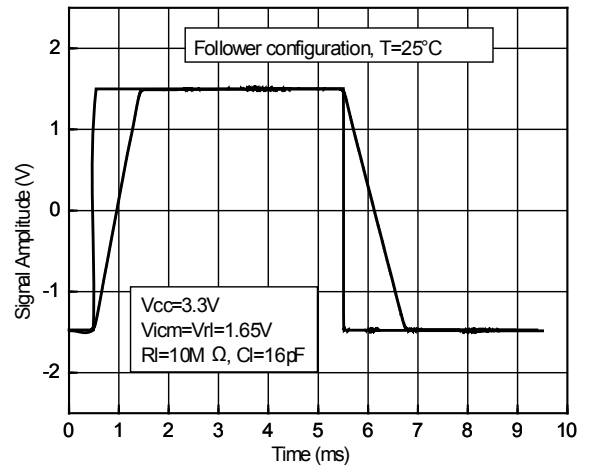
**Figure 14. Output swing vs. input signal frequency**



**Figure 15. Small signal response at 3.3 V supply voltage**



**Figure 16. Large signal response at 3.3 V supply voltage**



**Figure 17. Bode diagram at 3.3 V supply voltage**

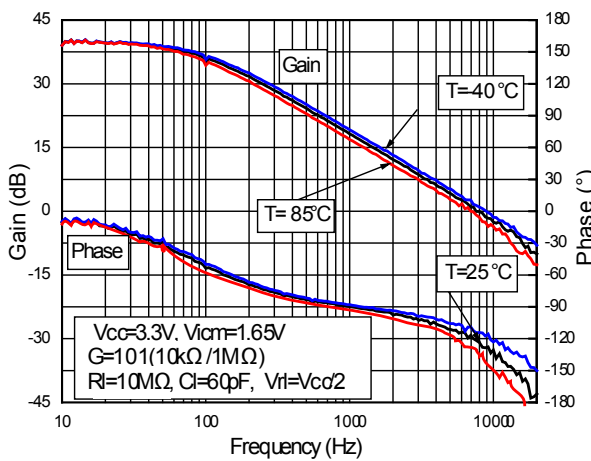

**Figure 18. Noise at 3.3 V supply voltage in follower configuration**

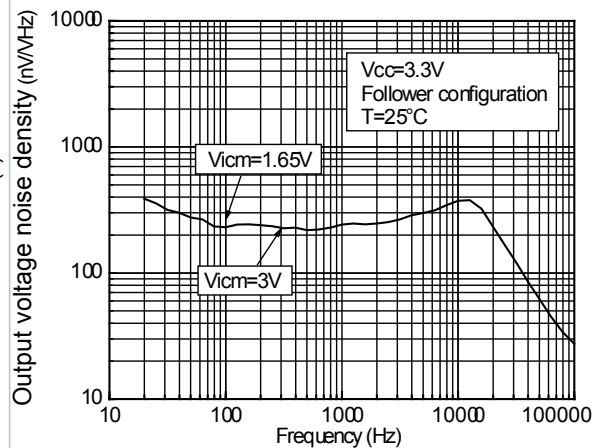

**Figure 19.  $R_{iso}$  to drive capacitors above 100 pF in follower configuration**

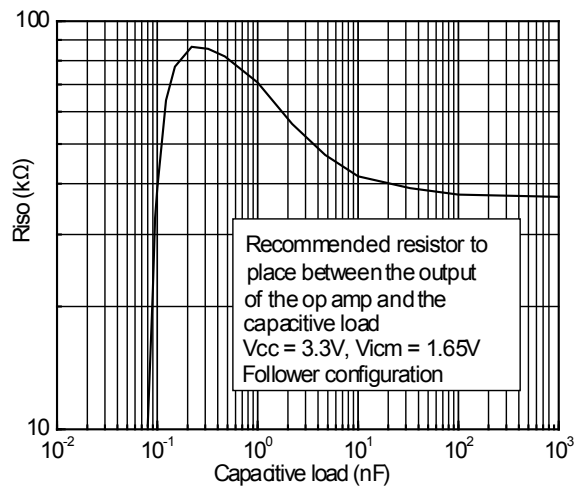

## 5 Package information

In order to meet environmental requirements, ST offers these devices in different grades of **ECOPACK** packages, depending on their level of environmental compliance. ECOPACK specifications, grade definitions and product status are available at: [www.st.com](http://www.st.com). ECOPACK is an ST trademark.

### 5.1 SC70-5 (or SOT323-5) package information

Figure 20. SC70-5 (or SOT323-5) package outline

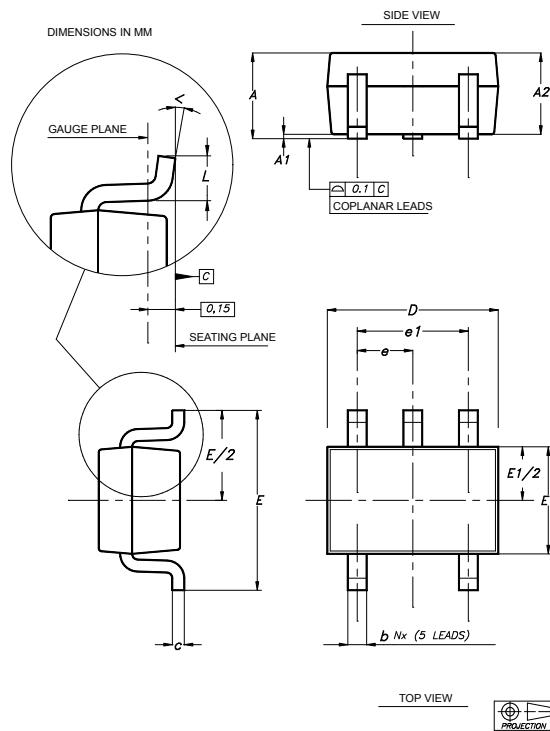

**Table 7. SC70-5 (or SOT323-5) package mechanical data**

Ref.	Dimensions					
	Millimeters			Inches		
	Min.	Typ.	Max.	Min.	Typ.	Max.
A	0.80		1.10	0.032		0.043
A1			0.10			0.004
A2	0.80	0.90	1.00	0.032	0.035	0.039
b	0.15		0.30	0.006		0.012
c	0.10		0.22	0.004		0.009
D	1.80	2.00	2.20	0.071	0.079	0.087
E	1.80	2.10	2.40	0.071	0.083	0.094
E1	1.15	1.25	1.35	0.045	0.049	0.053
e		0.65			0.025	
e1		1.30			0.051	
L	0.26	0.36	0.46	0.010	0.014	0.018
<	0°		8°	0°		8°

## 5.2 SOT23-5 package information

Figure 21. SOT23-5 package outline

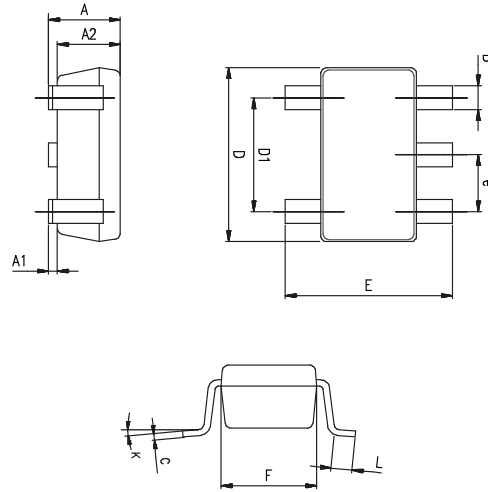

Table 8. SOT23-5 package mechanical data

Ref.	Dimensions					
	Millimeters			Inches		
	Min.	Typ.	Max.	Min.	Typ.	Max.
A	0.90	1.20	1.45	0.035	0.047	0.057
A1			0.15			0.006
A2	0.90	1.05	1.30	0.035	0.041	0.051
B	0.35	0.40	0.50	0.014	0.016	0.020
C	0.09	0.15	0.20	0.004	0.006	0.020
D	2.80	2.90	3.00	0.110	0.114	0.118
D1		1.90			0.075	
e		0.95			0.037	
E	2.60	2.80	3.00	0.102	0.110	0.118
F	1.50	1.60	1.75	0.059	0.063	0.069
L	0.10	0.35	0.60	0.004	0.014	0.024
K	0°		10°	0°		10°

### 5.3 MiniSO8 package information

Figure 22. MiniSO8 package outline

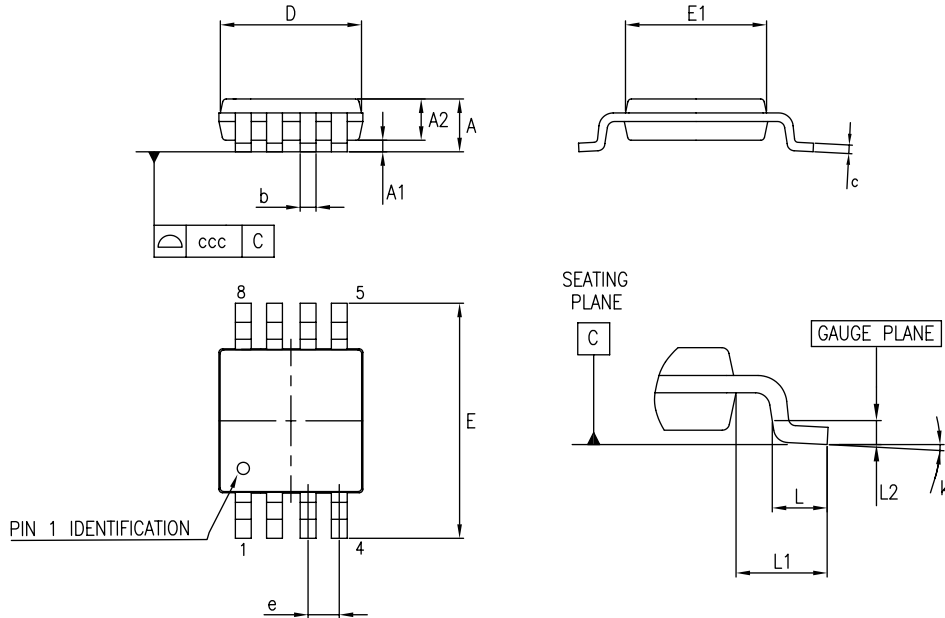

Table 9. MiniSO8 mechanical data

Dim.	Millimeters			Inches		
	Min.	Typ.	Max.	Min.	Typ.	Max.
A			1.1			0.043
A1	0		0.15	0		0.006
A2	0.75	0.85	0.95	0.03	0.033	0.037
b	0.22		0.4	0.009		0.016
c	0.08		0.23	0.003		0.009
D	2.8	3	3.2	0.11	0.118	0.126
E	4.65	4.9	5.15	0.183	0.193	0.203
E1	2.8	3	3.1	0.11	0.118	0.122
e		0.65			0.026	
L	0.4	0.6	0.8	0.016	0.024	0.031
L1		0.95			0.037	
L2		0.25			0.01	
k	0°		8°	0°		8°
ccc			0.1			0.004

## 5.4 TSSOP-14 package information

Figure 23. TSSOP-14 package outline

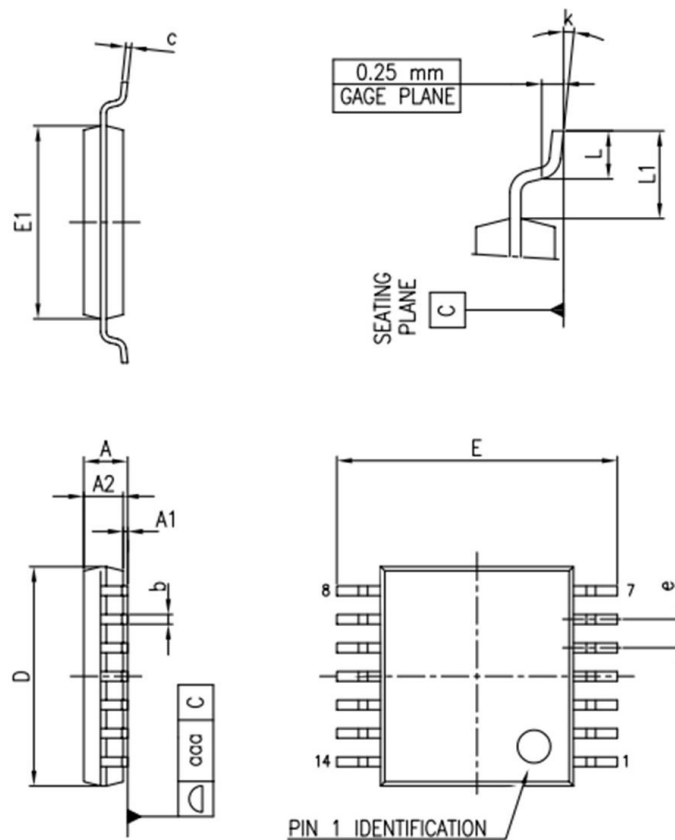

Table 10. TSSOP-14 mechanical data

Dim.	mm		
	Min.	Typ.	Max.
A			1.20
A1	0.05		0.15
A2	0.80	1.00	1.05
b	0.19		0.30
c	0.09		0.20
D	4.90	5.00	5.10
E	6.20	6.40	6.60
E1	4.30	4.40	4.50
e	0.65 BSC		
L	0.45	0.60	0.75
L1		1.00	
k	0		8
aaa			0.10

## 6 Ordering information

Table 11. Order code

Order code	Temperature range	Package	Marking
TSL6801ICT	-40 °C to 85 °C	SC70-5	KF
TSL6801RICT			KK
TSL6801ILT		SOT23-5	KF
TSL6801RILT			KK
TSL6802IST		MiniSO8	KI
TSL6804IPT		TSSOP-14	6804!

## Revision history

**Table 12. Document revision history**

Date	Version	Changes
02-Dec-2021	1	Initial release.
23-Apr-2024	2	Added <a href="#">Figure 2</a> , TSL6801RICT and TSL6801RILT in <a href="#">Table 11</a> . Updated <a href="#">Table 1</a>



## Contents

<b>1</b>	<b>Pin description</b> .....	<b>2</b>
1.1	TSL6801 single operational amplifier .....	2
1.2	TSL6802 dual operational amplifier .....	3
1.3	TSL6804 quad operational amplifier .....	4
<b>2</b>	<b>Absolute maximum ratings</b> .....	<b>5</b>
<b>3</b>	<b>Electrical characteristics</b> .....	<b>6</b>
<b>4</b>	<b>Typical performance characteristics</b> .....	<b>7</b>
<b>5</b>	<b>Package information</b> .....	<b>10</b>
5.1	SC70-5 (or SOT323-5) package information .....	10
5.2	SOT23-5 package information .....	12
5.3	MiniSO8 package information .....	13
5.4	TSSOP-14 package information .....	14
<b>6</b>	<b>Ordering information</b> .....	<b>15</b>
	<b>Revision history</b> .....	<b>16</b>

## List of tables

<b>Table 1.</b>	SC70-5 and SOT23-5 pin description for the TSL6801 and the TSL6801R . . . . .	2
<b>Table 2.</b>	MiniSO8 pin description . . . . .	3
<b>Table 3.</b>	TSSOP-14 pin description . . . . .	4
<b>Table 4.</b>	Absolute maximum ratings . . . . .	5
<b>Table 5.</b>	Operating conditions . . . . .	5
<b>Table 6.</b>	Electrical characteristics at $V_{CC} = 1.8\text{ V to }5.5\text{ V}$ , $V_{ICM} = V_{OUT} = V_{CC} / 2$ , $T = 25\text{ }^{\circ}\text{C}$ and OUT connected to $V_{CC} / 2$ through $R_L = 10\text{ k}\Omega$ (unless otherwise specified) . . . . .	6
<b>Table 7.</b>	SC70-5 (or SOT323-5) package mechanical data . . . . .	11
<b>Table 8.</b>	SOT23-5 package mechanical data . . . . .	12
<b>Table 9.</b>	MiniSO8 mechanical data . . . . .	13
<b>Table 10.</b>	TSSOP-14 mechanical data . . . . .	14
<b>Table 11.</b>	Order code . . . . .	15
<b>Table 12.</b>	Document revision history . . . . .	16

## List of figures

<b>Figure 1.</b>	SC70-5 and SOT23-5 pin connections (top view) for the TSL6801 . . . . .	2
<b>Figure 2.</b>	SC70-5 and SOT23-5 pin connections (top view) for the TSL6801R . . . . .	2
<b>Figure 3.</b>	MiniSO8 pin connection (top view) . . . . .	3
<b>Figure 4.</b>	TSSOP-14 pin connections (top view) . . . . .	4
<b>Figure 5.</b>	Supply current vs. supply voltage . . . . .	7
<b>Figure 6.</b>	Input offset voltage distribution . . . . .	7
<b>Figure 7.</b>	Input offset voltage vs. common mode voltage . . . . .	7
<b>Figure 8.</b>	Input offset voltage temperature coefficient distribution . . . . .	7
<b>Figure 9.</b>	Input bias current vs. temperature . . . . .	8
<b>Figure 10.</b>	Output characteristics at 3.3 V supply voltage . . . . .	8
<b>Figure 11.</b>	Desaturation time . . . . .	8
<b>Figure 12.</b>	Phase reversal free . . . . .	8
<b>Figure 13.</b>	Slew rate vs. supply voltage . . . . .	8
<b>Figure 14.</b>	Output swing vs. input signal frequency . . . . .	8
<b>Figure 15.</b>	Small signal response at 3.3 V supply voltage . . . . .	9
<b>Figure 16.</b>	Large signal response at 3.3 V supply voltage . . . . .	9
<b>Figure 17.</b>	Bode diagram at 3.3 V supply voltage . . . . .	9
<b>Figure 18.</b>	Noise at 3.3 V supply voltage in follower configuration . . . . .	9
<b>Figure 19.</b>	$R_{iso}$ to drive capacitors above 100 pF in follower configuration . . . . .	9
<b>Figure 20.</b>	SC70-5 (or SOT323-5) package outline . . . . .	10
<b>Figure 21.</b>	SOT23-5 package outline . . . . .	12
<b>Figure 22.</b>	MiniSO8 package outline . . . . .	13
<b>Figure 23.</b>	TSSOP-14 package outline . . . . .	14

**IMPORTANT NOTICE – READ CAREFULLY**

STMicroelectronics NV and its subsidiaries (“ST”) reserve the right to make changes, corrections, enhancements, modifications, and improvements to ST products and/or to this document at any time without notice. Purchasers should obtain the latest relevant information on ST products before placing orders. ST products are sold pursuant to ST’s terms and conditions of sale in place at the time of order acknowledgment.

Purchasers are solely responsible for the choice, selection, and use of ST products and ST assumes no liability for application assistance or the design of purchasers’ products.

No license, express or implied, to any intellectual property right is granted by ST herein.

Resale of ST products with provisions different from the information set forth herein shall void any warranty granted by ST for such product.

ST and the ST logo are trademarks of ST. For additional information about ST trademarks, refer to [www.st.com/trademarks](http://www.st.com/trademarks). All other product or service names are the property of their respective owners.

Information in this document supersedes and replaces information previously supplied in any prior versions of this document.

© 2024 STMicroelectronics – All rights reserved