

# TSP70R1K1S1

## 700V 4.5A N-Channel SJ-MOSFET

### General Description

Truesemi SJ-FET is new generation of high voltage MOSFET family that is utilizing an advanced charge balance mechanism for outstanding low on-resistance and lower gate charge performance. This advanced technology has been tailored to minimize conduction loss, provide superior switching performance, and withstand extreme  $dv/dt$  rate and higher avalanche energy. SJ-FET is suitable for various AC/DC power conversion in switching mode operation for higher efficiency.

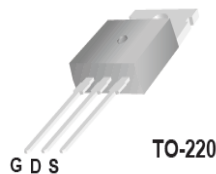

### Features

- 750V @  $T_J = 150^\circ\text{C}$
- Typ.  $R_{DS(on)} = 0.95\Omega$
- Ultra Low gate charge (typ.  $Q_g = 15\text{nC}$ )
- 100% avalanche tested



### Absolute Maximum Ratings

Symbol	Parameter	Value	Unit
$V_{DSS}$	Drain-Source Voltage	700	V
$I_D$	Drain Current -Continuous ( $TC = 25^\circ\text{C}$ )	4.5	A
	-Continuous ( $TC = 100^\circ\text{C}$ )	2.9	
$I_{DM}$	Drain Current – Pulsed (Note 1)	12	A
$V_{GSS}$	Gate-Source voltage	$\pm 30$	V
$E_{AS}$	Single Pulsed Avalanche Energy (Note 2)	46	mJ
$I_{AR}$	Avalanche Current (Note 1)	1	A
$E_{AR}$	Repetitive Avalanche Energy (Note 1)	0.2	mJ
$dv/dt$	Peak Diode Recovery $dv/dt$ (Note 3)	15	V/ns
$P_D$	Power Dissipation ( $TC = 25^\circ\text{C}$ )	37	W
	-Derate above $25^\circ\text{C}$	1.67	
$T_J, T_{STG}$	Operating and Storage Temperature Range	-55 to +150	$^\circ\text{C}$
$T_L$	Maximum Lead Temperature for Soldering Purpose, 1/8" from Case for 5 Seconds	300	$^\circ\text{C}$

\* Drain current limited by maximum junction temperature.

### Thermal Characteristics

Symbol	Parameter	Value	Unit
$R_{\theta JC}$	Thermal Resistance, Junction-to-Case	3.41	$^\circ\text{C/W}$
$R_{\theta CS}$	Thermal Resistance, Case-to-Sink Typ.	0.5	$^\circ\text{C/W}$
$R_{\theta JA}$	Thermal Resistance, Junction-to-Ambient	62	$^\circ\text{C/W}$

## Electrical Characteristics TC = 25 °C unless otherwise noted

Symbol	Parameter	Conditions	Min	Typ	Max	Unit
Off Characteristics						
BV <sub>DSS</sub>	Drain-Source Breakdown Voltage	V <sub>GS</sub> = 0V, I <sub>D</sub> = 250μA, T <sub>J</sub> = 25 °C	700	--	--	V
		V <sub>GS</sub> = 0V, I <sub>D</sub> = 250μA, T <sub>J</sub> = 150 °C	--	750	--	V
ΔBV <sub>DSS</sub> / ΔT <sub>J</sub>	Breakdown Voltage Temperature Coefficient	I <sub>D</sub> = 250μA, Referenced to 25 °C	--	0.6	--	V/°C
I <sub>DSS</sub>	Zero Gate Voltage Drain Current	V <sub>DS</sub> = 700V, V <sub>GS</sub> = 0V -T <sub>J</sub> = 150 °C	--	-- 10	1 --	μA μA
I <sub>GSSF</sub>	Gate-Body Leakage Current, Forward	V <sub>GS</sub> = 30V, V <sub>DS</sub> = 0V	--	--	100	nA
I <sub>GSSR</sub>	Gate-Body Leakage Current, Reverse	V <sub>GS</sub> = -30V, V <sub>DS</sub> = 0V	--	--	-100	nA
On Characteristics						
V <sub>GS(th)</sub>	Gate Threshold Voltage	V <sub>DS</sub> = V <sub>GS</sub> , I <sub>D</sub> = 250μA	2.5	--	4.5	V
R <sub>DS(on)</sub>	Static Drain-Source On-Resistance	V <sub>GS</sub> = 10V, I <sub>D</sub> = 2.5A	--	0.95	1.1	Ω
g <sub>FS</sub>	Forward Trans conductance	V <sub>DS</sub> = 40V, I <sub>D</sub> = 2.5A (Note 4)	--	8	--	S
R <sub>g</sub>	Gate resistance	f=1MHz, open drain	--	3.5	--	Ω
Dynamic Characteristics						
C <sub>iss</sub>	Input Capacitance	V <sub>DS</sub> = 25V, V <sub>GS</sub> = 0V, f = 1.0MHz	--	320	--	pF
C <sub>oss</sub>	Output Capacitance		--	75	--	pF
C <sub>rss</sub>	Reverse Transfer Capacitance		--	5	--	pF
Switching Characteristics						
t <sub>d(on)</sub>	Turn-On Delay Time	V <sub>DD</sub> = 400V, I <sub>D</sub> = 2.5A R <sub>G</sub> = 20Ω (Note 4, 5)	--	10	--	ns
t <sub>r</sub>	Turn-On Rise Time		--	8	--	ns
t <sub>d(off)</sub>	Turn-Off Delay Time		--	60	--	ns
t <sub>f</sub>	Turn-Off Fall Time		--	13	--	ns
Q <sub>g</sub>	Total Gate Charge	V <sub>DS</sub> = 480V, I <sub>D</sub> = 2.5A V <sub>GS</sub> = 10V (Note 4, 5)	--	15	--	nC
Q <sub>gs</sub>	Gate-Source Charge		--	3	--	nC
Q <sub>gd</sub>	Gate-Drain Charge		--	6	--	nC
Drain-Source Diode Characteristics and Maximum Ratings						
I <sub>S</sub>	Maximum Continuous Drain-Source Diode Forward Current		--	--	4.5	A
I <sub>SM</sub>	Maximum Pulsed Drain-Source Diode Forward Current		--	--	16	A
V <sub>SD</sub>	Drain-Source Diode Forward Voltage	V <sub>GS</sub> = 0V, I <sub>F</sub> = 2.5A	--	0.9	1.5	V
t <sub>rr</sub>	Reverse Recovery Time	V <sub>GS</sub> = 0V, I <sub>F</sub> = 2.5A di <sub>F</sub> /dt = 100A/μs (Note 4)	--	180	--	ns
Q <sub>rr</sub>	Reverse Recovery Charge		--	1.5	--	μC

## NOTES:

1. Repetitive Rating: Pulse width limited by maximum junction temperature
2. I<sub>AS</sub>=1A, V<sub>DD</sub>=50V, Starting T<sub>J</sub>=25 °C
3. I<sub>SD</sub>≤4.5A, di/dt ≤ 200A/μs, V<sub>DD</sub> ≤ BV<sub>DSS</sub>, Starting T<sub>J</sub> = 25 °C
4. Pulse Test: Pulse width ≤ 300μs, Duty Cycle ≤ 2%
5. Essentially Independent of Operating Temperature Typical Characteristics

# Typical Performance Characteristics

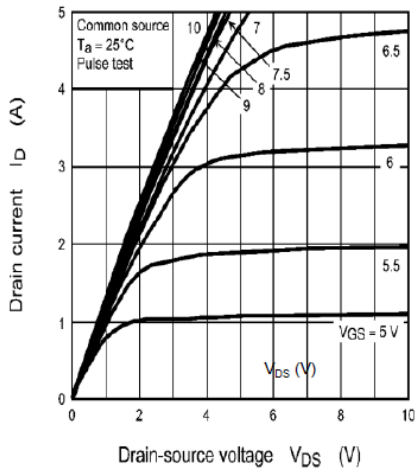

Figure 1: On-Region Characteristics@25°C

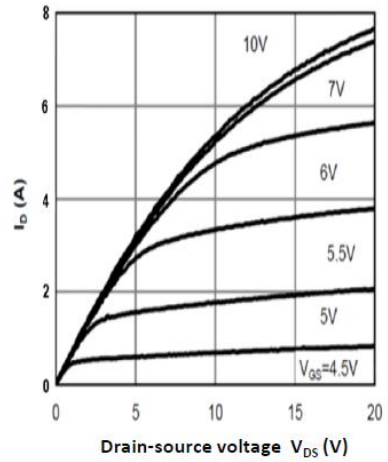

Figure 2: On-Region Characteristics@125°C

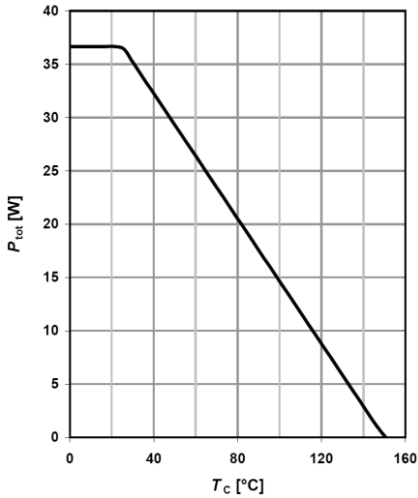

Figure 3: Power Dissipation

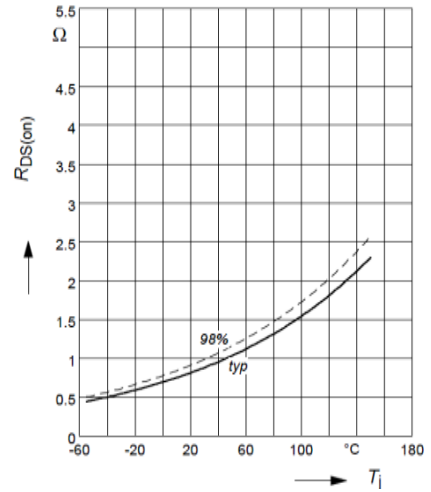

Figure 4: On-Resistance vs. Junction Temperature

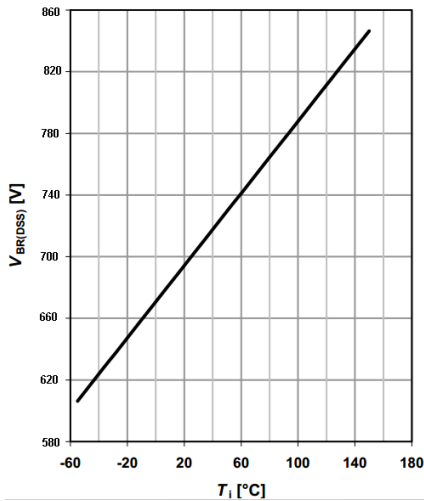

Figure 5: Break Down vs. Junction Temperature

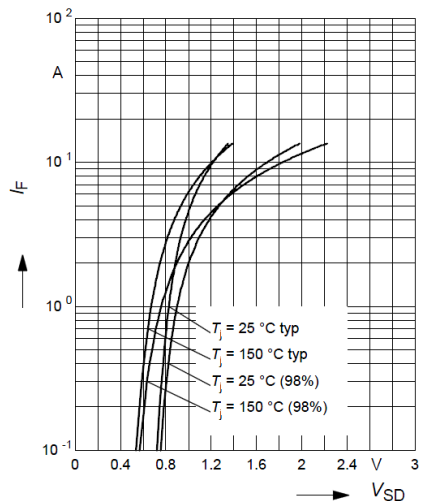

Figure 6: Body-Diode Characteristics

# Typical Performance Characteristics

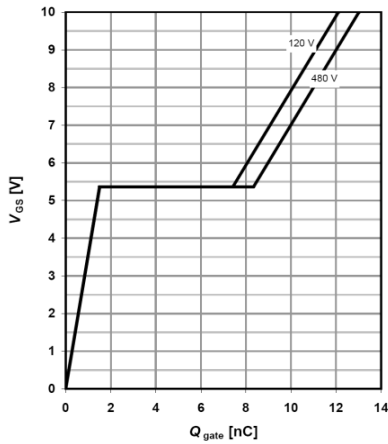

Figure 7: Gate-Charge Characteristics

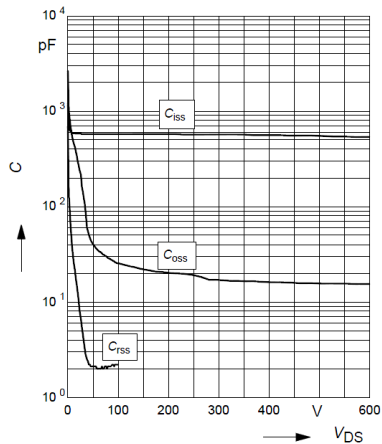

Figure 8: Capacitance Characteristics

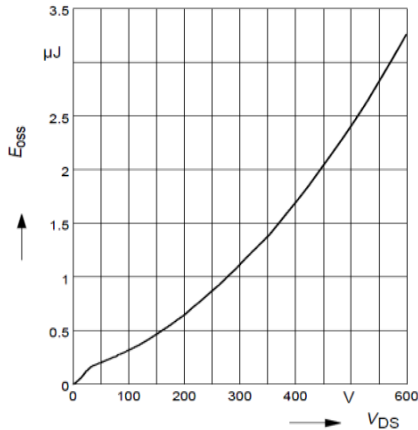

Figure 9:  $C_{oss}$  stored Energy

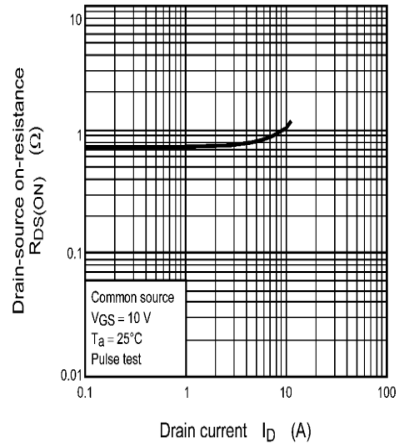

Figure 10: On-Resistance vs. Drain Current and Gate Voltage

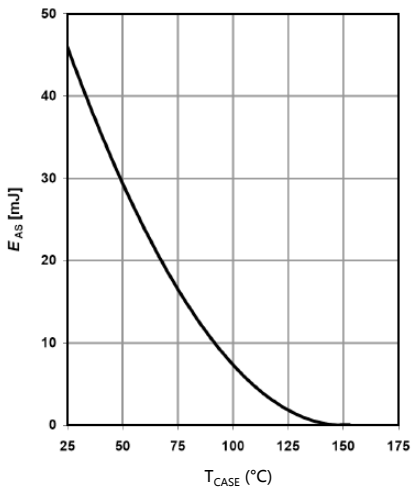

Figure 11: Avalanche energy

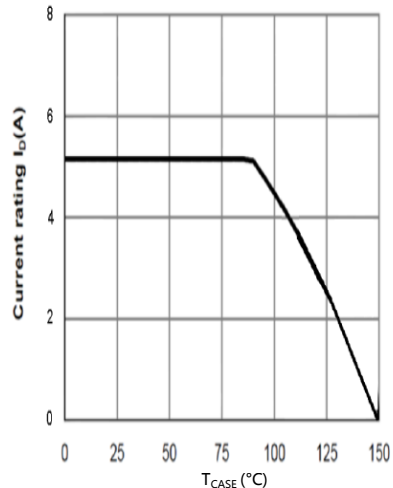

Figure 12: Current De-rating

# Typical Performance Characteristics

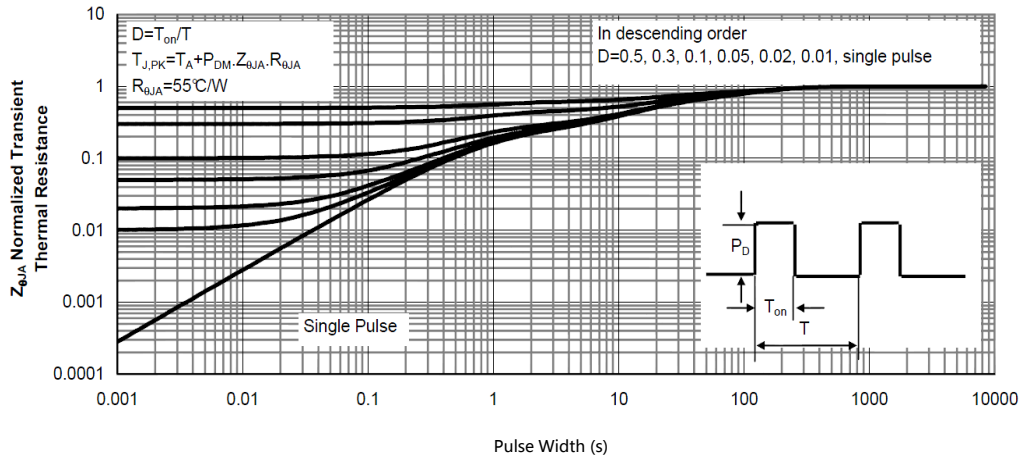

Figure 13: Normalized Maximum Transient Thermal Impedance

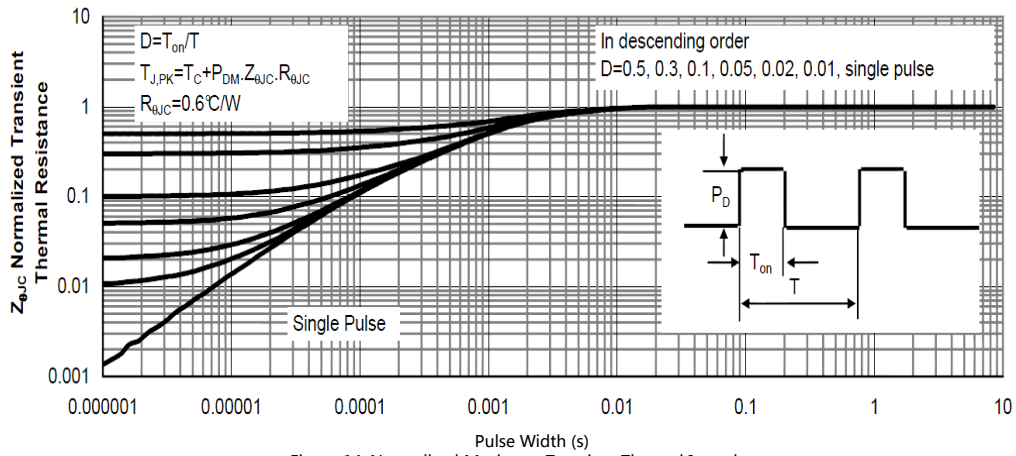
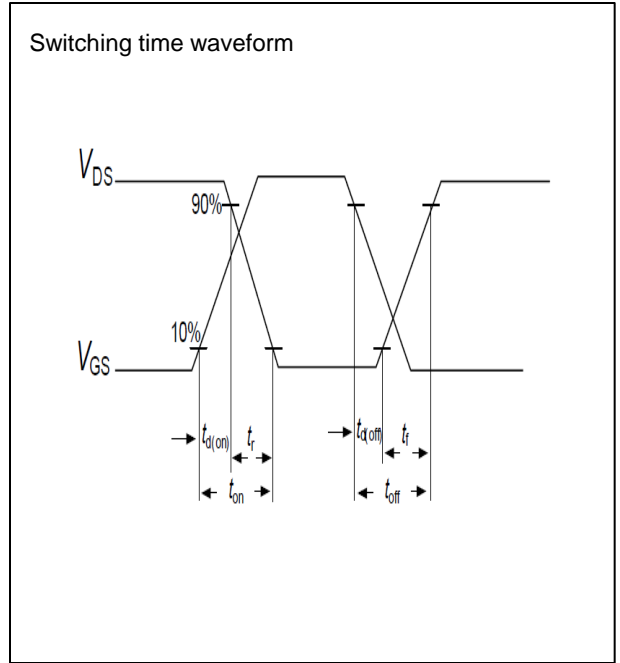
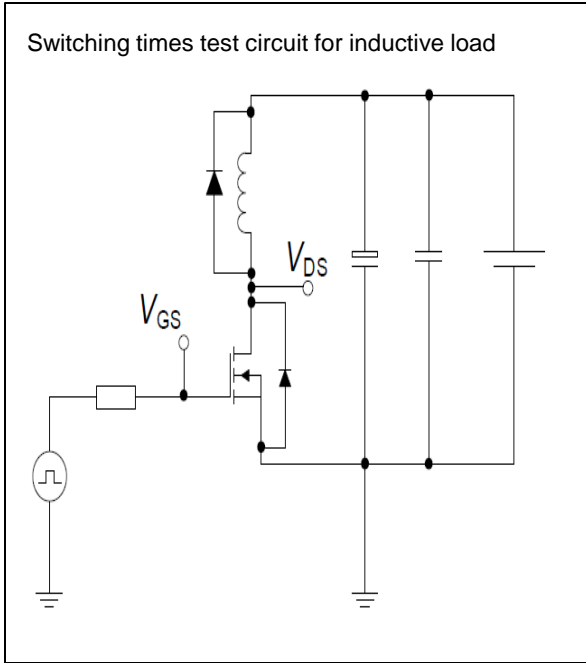

Figure 14: Normalized Maximum Transient Thermal Impedance

# Test circuits

## Switching times test circuit and waveform for inductive load



## Unclamped inductive load test circuit and waveform

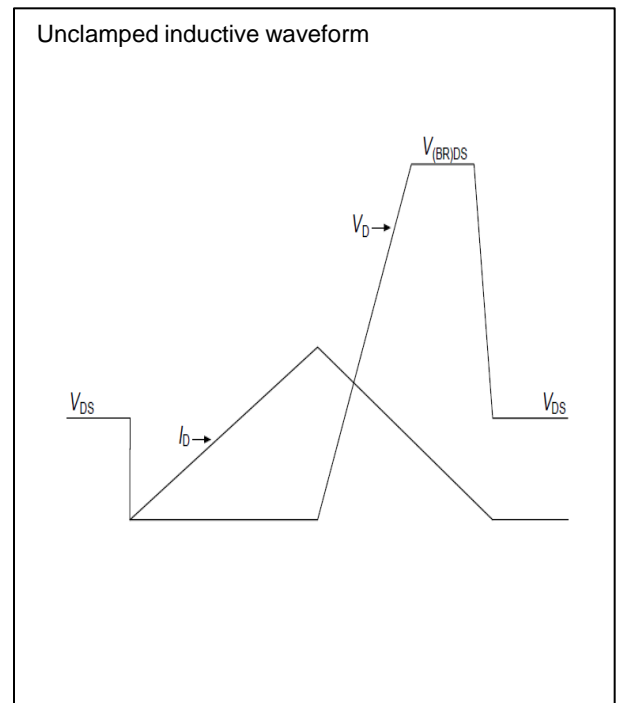
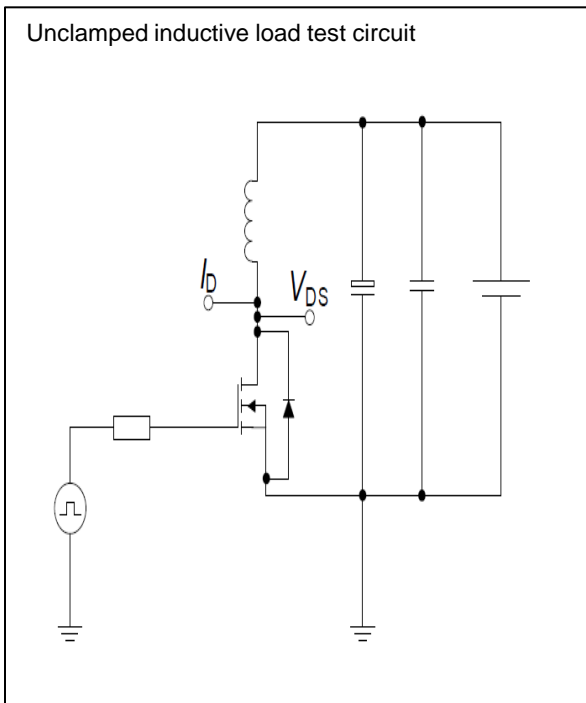

# Test circuits

## Test circuit and waveform for diode characteristics

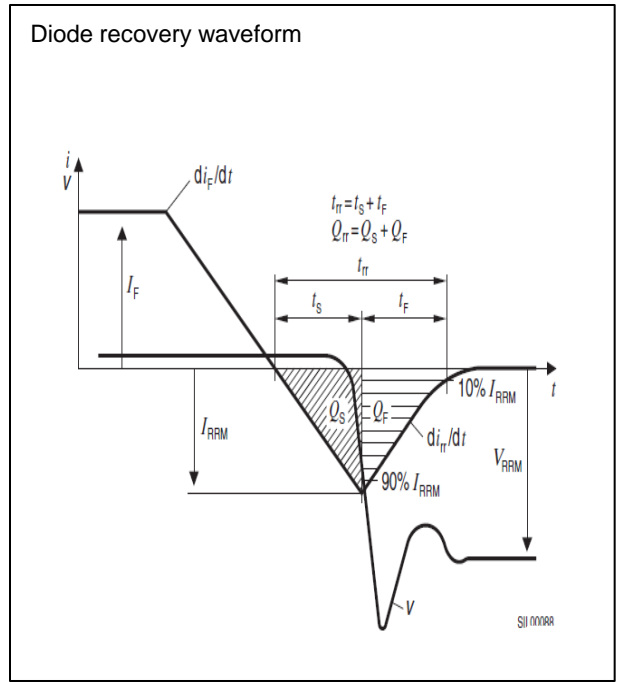
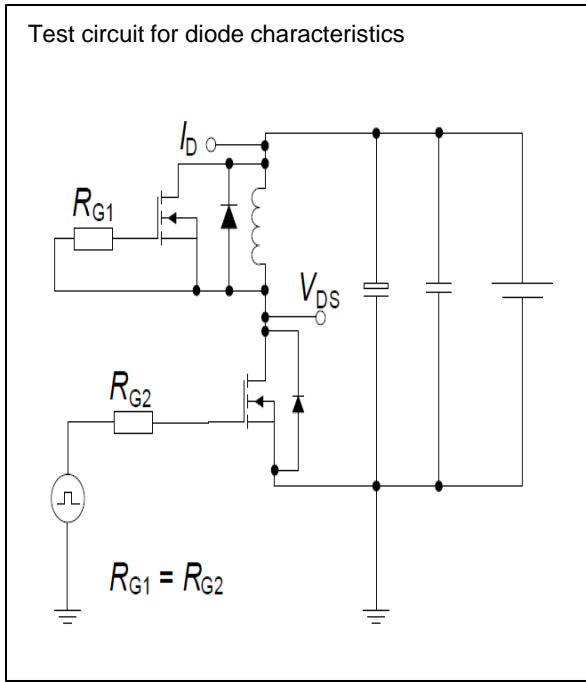

# Package Outline TO-220

TSP70R1K1S1 700V 4.5A N-Channel SJ-MOSFET

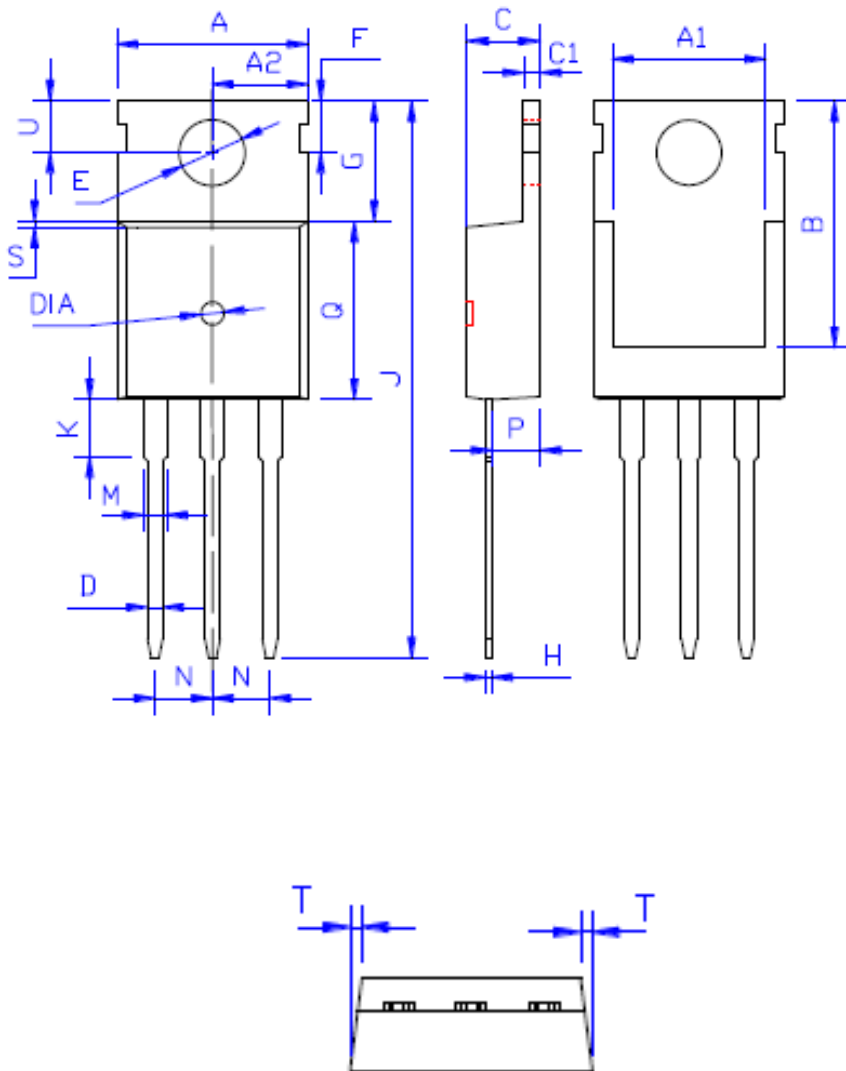

DIM	MILLIMETERS
A	10.00 ± 0.30
A1	8.00 ± 0.30
A2	5.00 ± 0.30
B	13.20 ± 0.40
C	4.50 ± 0.20
C1	1.30 ± 0.20
D	0.80 ± 0.20
E	3.60 ± 0.20
F	3.00 ± 0.30
G	6.60 ± 0.40
H	0.50 ± 0.20
J	28.88 ± 0.50
K	3.00 ± 0.30
M	1.30 ± 0.30
N	Typical 2.54
P	2.40 ± 0.40
Q	9.20 ± 0.40
S	0.25 ± 0.15
T	0.25 ± 0.15
U	2.80 ± 0.30
DIA	宽 1.50 ± 0.10 深 0.50 <b>MAX</b>