



TSR40A With Pump/Reservoir Option

General

The TS Series central chillers are designed for indoor use in industrial manufacturing locations. The chillers are produced in our ISO 9001:2000 certified facility. Water-cooled units ship with a full refrigerant charge. Units with a remote air-cooled condenser ship with a nitrogen charge. All units are built on a rugged industrial duty frame and are finished with air-dry enamel paint.

Mechanical Features

- Energy efficient and reliable scroll compressor(s)
- Stainless steel copper brazed plate evaporators provide corrosion protection, compact size and higher heat transfer coefficients
- Two completely independent refrigerant circuits
- Evaporator water supply and return manifolds
- (Water-Cooled Units) Condenser water supply and return manifolds
- (Water-Cooled Units) Generously sized cleanable shell-and-tube water-cooled condenser for industrial environments
- (Remote Condenser Units) Modular design with divided fan sections to prevent 'wind-milling' during fan cycling. Includes galvanized steel fan sections and coil baffles, copper tube/aluminum fin coils tested to 400 PSIG, direct drive multi-blade propeller fans with venture orifices to optimize efficiency, and a nitrogen holding charge.
- (Water-Cooled Units) Condenser water regulating valves to maintain constant refrigerant head pressures
- Refrigerant TXV, filter/drier, and sight glasses
- Freezestat safety switch with solid state sensors
- Encapsulated high and low refrigerant pressure safeties
- Fail safe flow switches interlocked with compressors
- Y-strainer for each evaporator to protect evaporators from contamination

- Electronic hot gas bypass for capacity control (two compressor units)
- Four-step compressor staging for capacity control (four compressor units)
- (Water-Cooled Units) Factory tested under full load conditions prior to shipment

Electrical Features

- NEMA-4 electrical enclosure
- Control transformer to provide 115V/1/60 control voltage
- Compressor starters (and pump starters if pump tank option is purchased) mounted in control panel and wired to motors
- Single-point main power block for simple wiring connection
- Alarm horn and silence switch

PLC Features

- Operator Control Station PLC (integrated Intel based microprocessor controller, operator interface, solid state input/output relays)
- Two line, 20 character alphanumeric display
- Digital set point and temperature deviation alarm adjustment with password protection
- Digital display of process water supply and return temperatures
- Alarm history screen
- User selectable lead/lag of refrigerant circuits
- Compressor anti-cycle timers
- Compressor running hours
- Mechanical safety interlocks for each circuit including low flow, high refrigerant pressure, low refrigerant pressure, freezestat, compressor fault and pump fault (pump fault only available on units with the optional pump tank)
- System faults for high and low temperature deviation alarms and probe fault alarm
- Display temperatures easily switched from °F to °C from the front panel
- Easy front panel alarm reset button

Warranty

- 12 months parts and labor

TSW20A & TSW30A Water-Cooled Chillers

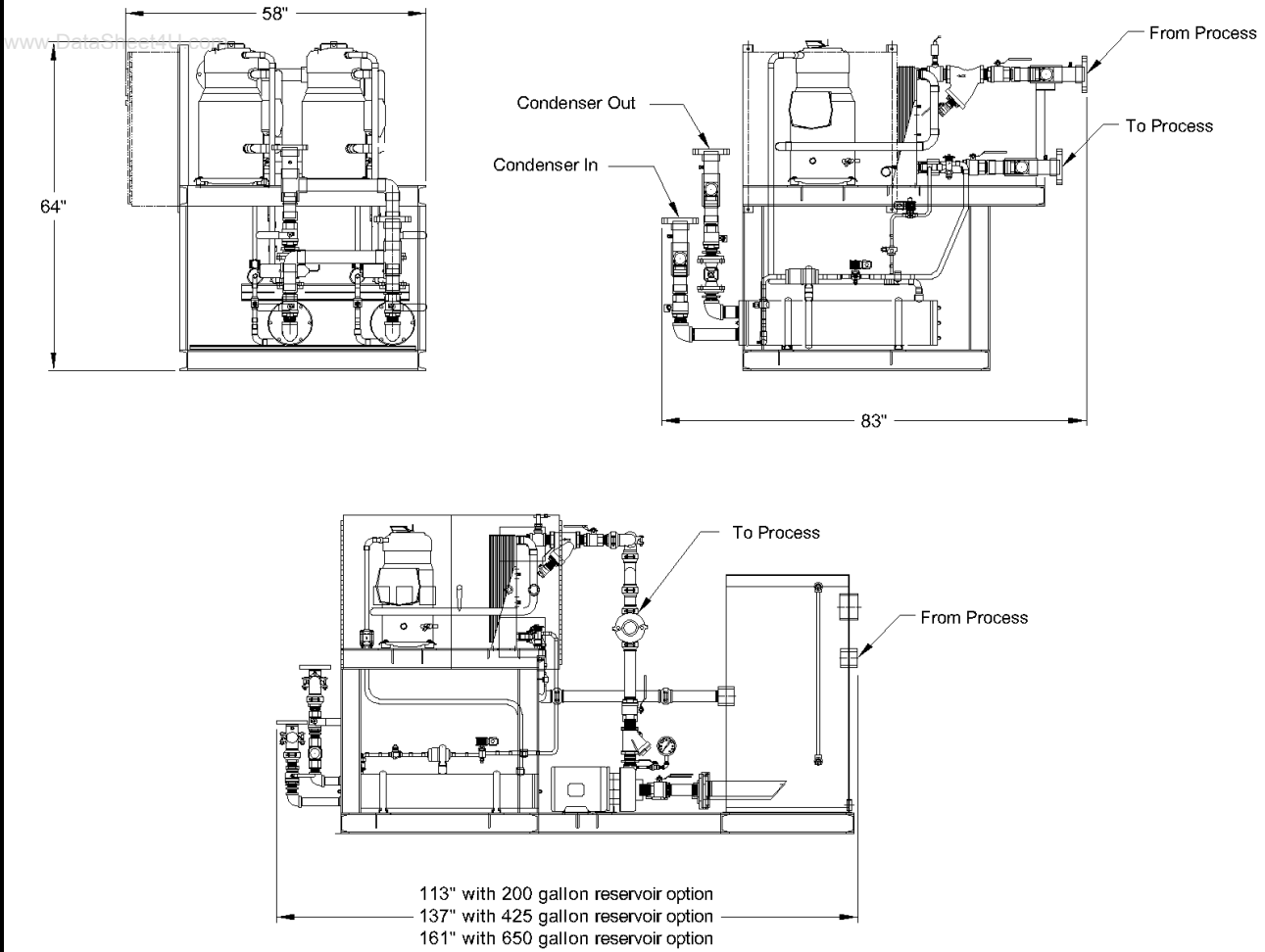

Model	TSW20A	TSW30A
Cooling Capacity (Tons) ¹	23	35
Set Point Range (°F)	20 – 80	20 – 80
Number of Compressors	2	2
Refrigerant Type	HCFC-22	HCFC-22
Condenser Water Flow Requirement (GPM)	63	96
To & From Process Manifold Connections (for units designed for standard flow to process, 2.4 GPM/ton)	2"	2 1/2"
To & From Process Manifold Connections (for units designed for double flow to process, 4.8 GPM/ton)	2"	3"
Condenser Manifold In & Out Connections	2"	2 1/2"
Unit MCA @ 460/3/60 (chiller only) ²	43	64
Unit MCA @ 460/3/60 (chiller & standard coolant flow pumps) ²	53	78
Unit MCA @ 460/3/60 (chiller & double coolant flow pumps) ²	61	81
Shipping Weight, Chiller (Lbs.)	1,600	2,000
Shipping Weight, Chiller With 200 Gallon Tank (Lbs.) ³	3,100	3,500
Shipping Weight, Chiller With 425 Gallon Tank (Lbs.) ³	4,100	4,500
Shipping Weight, Chiller With 650 Gallon Tank (Lbs.) ³	4,600	5,000

¹Cooling capacity based on 12,000 BTU/Hr/ton with 55°F leaving coolant and 85°F condenser water.

²MCA (Minimum Circuit Ampacity) is 125% of the largest compressor RLA plus 100% of any remaining compressor RLAs (and all pump FLAs if pump tank option is purchased) plus control circuit transformer. If a dual standby pump is order MCA will be higher.

³Shipping weight includes weight of double flow pump set and dual standby pump options.

TSW40A - TSW100A Water-Cooled Chillers

www.DataSheet4U.com

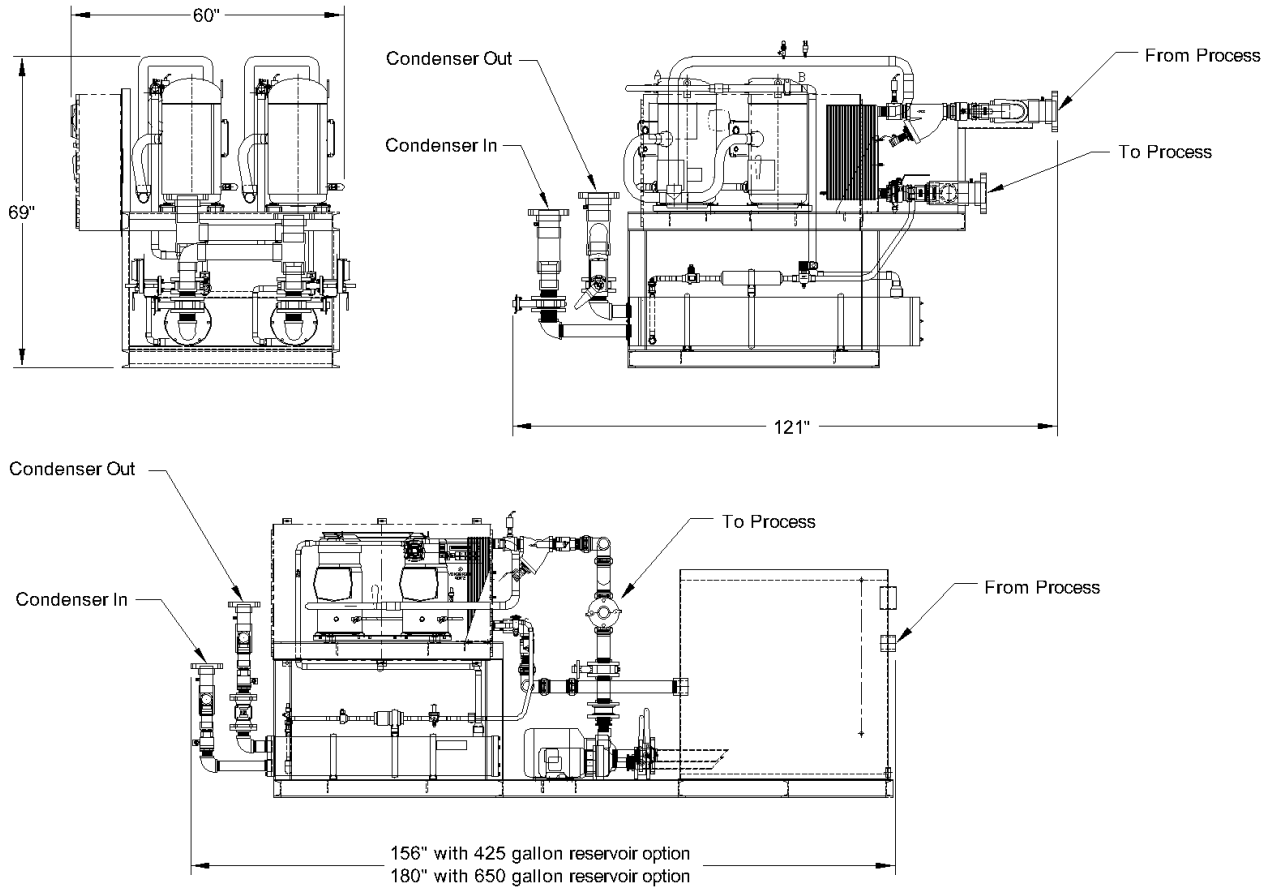

Model	TSW40A	TSW50A	TSW60A	TSW80A	TSW100A
Cooling Capacity (Tons) ¹	46	57	69	90	110
Set Point Range (°F)	20 – 80	20 – 80	20 – 80	20 – 80 ²	20 – 80 ²
Number of Compressors	4	4	4	4	4
Refrigerant Type	HCFC-22	HCFC-22	HCFC-22	HCFC-22	HCFC-22
Condenser Water Flow Requirement (GPM)	126	156	189	246	300
To & From Process Manifold Connections (for units designed for standard flow to process, 2.4 GPM/ton)	2 1/2"	3"	3"	4"	4"
To & From Process Manifold Connections (for units designed for double flow to process, 4.8 GPM/ton)	4"	4"	4"	6"	6"
Condenser Manifold In & Out Connections	3"	3"	4"	4"	4"
Unit MCA @ 460/3/60 (chiller only) ³	80	101	120	145	185
Unit MCA @ 460/3/60 (chiller & standard coolant flow pumps) ³	97	120	139	169	209
Unit MCA @ 460/3/60 (chiller & double coolant flow pumps) ³	102	125	151	182	222
Shipping Weight, Chiller (Lbs.)	2,500	3,400	3,900	4,300	4,900
Shipping Weight, Chiller With 200 Gallon Tank (Lbs.) ⁴	4,000	4,900	5,400	5,800	6,400
Shipping Weight, Chiller With 425 Gallon Tank (Lbs.) ⁴	5,000	5,900	6,400	6,800	7,400
Shipping Weight, Chiller With 650 Gallon Tank (Lbs.) ⁴	5,500	6,400	6,900	7,300	7,900

¹Cooling capacity based on 12,000 BTU/Hr/ton with 55°F leaving coolant and 85°F condenser water.

²Standard set point range is 20°F to 65°F for TSW80A & TSW100A. To extend range to 20°F to 80°F the CPR valve option is required.

³MCA (Minimum Circuit Ampacity) is 125% of the largest compressor RLA plus 100% of all remaining compressors RLAs (and all pump FLAs if pump tank option is purchased) plus control circuit transformer. If a dual standby pump is order MCA will be higher.

⁴Shipping weight includes weight of double flow pump set and dual standby pump options.

www.DataSheet4U.com

TSR20A & TSR30A Remote Air-Cooled Condenser Chillers

www.DataSheet4U.com

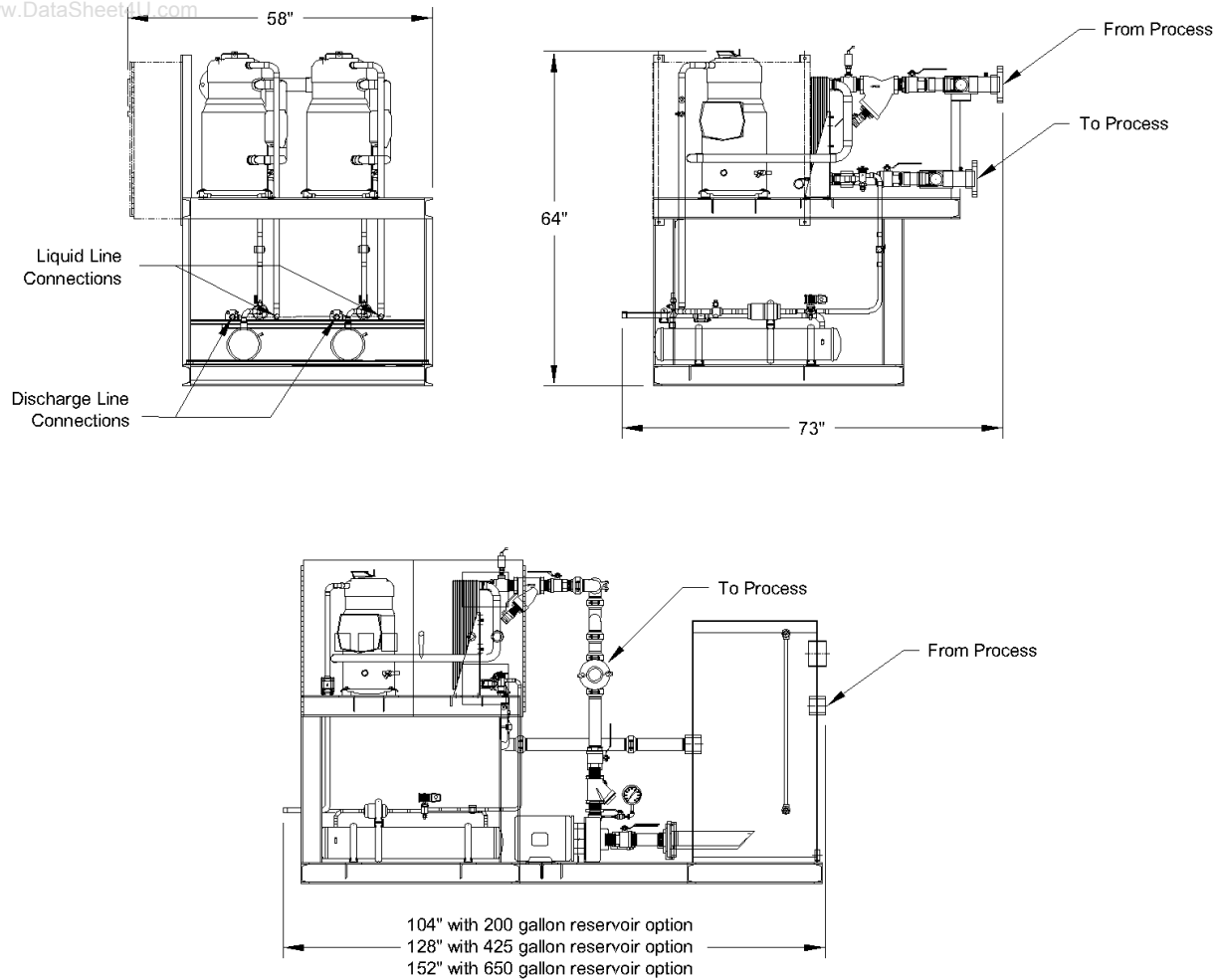

Model	TSR20A	TSR30A
Cooling Capacity (Tons) ¹	22	33
Set Point Range (°F)	20 – 80	20 - 80
Number of Compressors	2	2
Refrigerant Type	HCFC-22	HCFC-22
To & From Process Manifold Connections (for units designed for standard flow to process, 2.4 GPM/ton)	2"	2 1/2"
To & From Process Manifold Connections (for units designed for double flow to process, 4.8 GPM/ton)	2"	3"
Liquid Line Connection Size (inch)	5/8	7/8
Discharge Line Connection Size (inch)	7/8	1 1/8
Unit MCA @ 460/3/60 (chiller only) ²	43	64
Unit MCA @ 460/3/60 (chiller & standard flow pumps) ²	53	78
Unit MCA @ 460/3/60 (chiller & double flow pumps) ²	61	81
Shipping Weight, Chiller (Lbs.)	1,600	2,000
Shipping Weight, Chiller With 200 Gallon Tank (Lbs.) ³	3,100	3,500
Shipping Weight, Chiller With 425 Gallon Tank (Lbs.) ³	4,100	4,500
Shipping Weight, Chiller With 650 Gallon Tank (Lbs.) ³	4,600	5,000

¹Cooling capacity based on 12,000 BTU/Hr/ton with 55°F leaving coolant and 95°F condenser air.

²MCA (Minimum Circuit Ampacity) is 125% of the largest compressor RLA plus 100% of all remaining compressors RLAs (and all pump FLAs if pump tank option is purchased) plus 1 control circuit transformer. If a dual standby pump is order MCA will be higher.

³Shipping weight includes weight of double flow pump set including dual standby pump and condenser water manifolds.

TSR40A – TSR100A Remote Air-Cooled Condenser Chillers

www.DataSheet4U.com

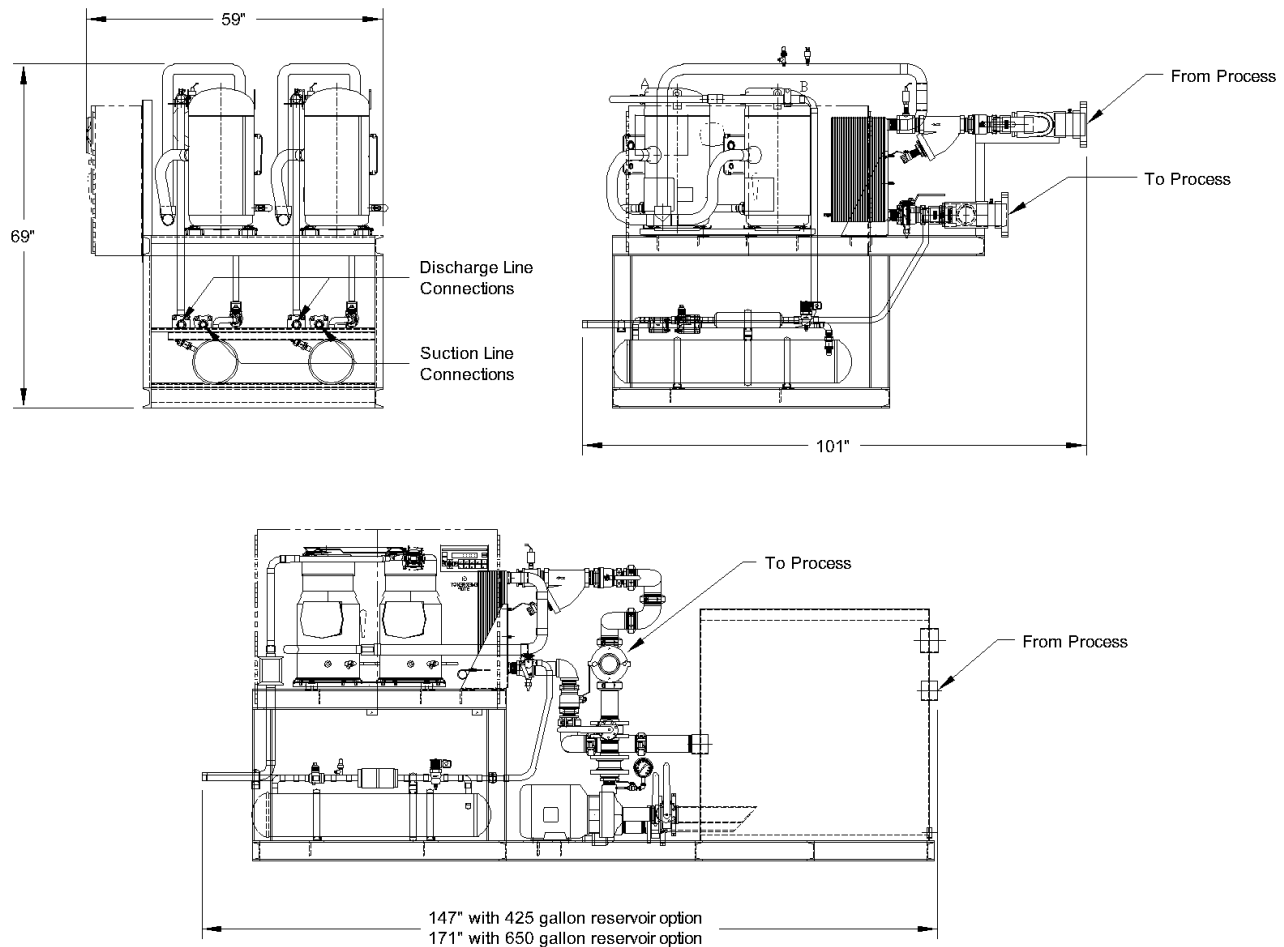

Model	TSR40A	TSR50A	TSR60A	TSR80A	TSR100A
Cooling Capacity (Tons) ¹	43	53	63	83	102
Set Point Range (°F)	20 – 80	20 – 80	20 – 80	20 – 80 ²	20 – 80 ²
Number of Compressors	4	4	4	4	4
Refrigerant Type	HCFC-22	HCFC-22	HCFC-22	HCFC-22	HCFC-22
To & From Process Manifold Connections (for units designed for standard flow to process, 2.4 GPM/ton)	2 1/2"	3"	3"	4"	4"
To & From Process Manifold Connections (for units designed for double flow to process, 4.8 GPM/ton)	4"	4"	4"	6"	6"
Liquid Line Connection Size (inch)	7/8	1 1/8	1 1/8	1 1/8	1 1/8
Discharge Line Connection Size (inch)	1 1/8	1 3/8	1 3/8	1 5/8	1 5/8
Unit MCA @ 460/3/60 (chiller only) ³	80	101	120	145	185
Unit MCA @ 460/3/60 (chiller & standard flow pumps) ³	97	120	139	169	209
Unit MCA @ 460/3/60 (chiller & double flow pumps) ³	102	125	151	182	222
Shipping Weight, Chiller (Lbs.)	2,500	3,400	3,900	4,300	4,900
Shipping Weight, Chiller With 200 Gallon Tank (Lbs.) ⁴	4,000	4,900	5,400	5,800	6,400
Shipping Weight, Chiller With 425 Gallon Tank (Lbs.) ⁴	5,000	5,900	6,400	6,800	7,400
Shipping Weight, Chiller With 650 Gallon Tank (Lbs.) ⁴	5,500	6,400	6,900	7,300	7,900

¹Cooling capacity based on 12,000 BTU/Hr/ton with 55°F leaving coolant and 95°F condenser air.

²Standard set point range is 20°F to 65°F for TSR80A & TSR100A. To extend range to 20°F to 80°F the CPR valve option is required.

³MCA (Minimum Circuit Ampacity) is 125% of the largest compressor RLA plus 100% of all remaining compressors RLAs (and all pump FLAs if pump tank option is purchased) plus control circuit transformer. If a dual standby pump is order MCA will be higher.

⁴Shipping weight includes weight of double flow pump set including dual standby pump and condenser water manifolds.

www.DataSheet4U.com

Remote Condensers For TSR20A – TSR50A Remote Air-Cooled Chillers

LAVB-22310

www.DataSheet4U.com

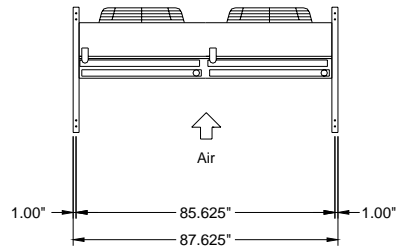
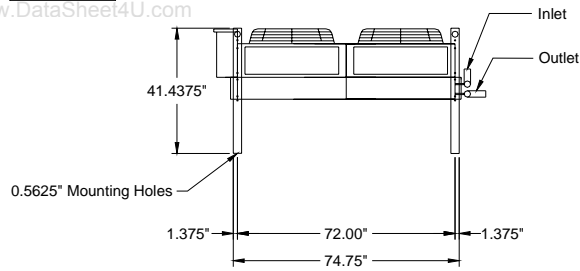

LAVB-23310
LAVB-23410

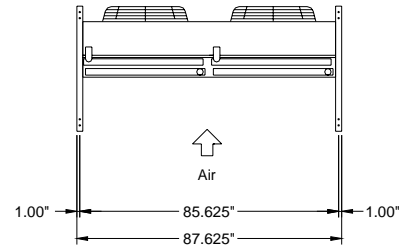
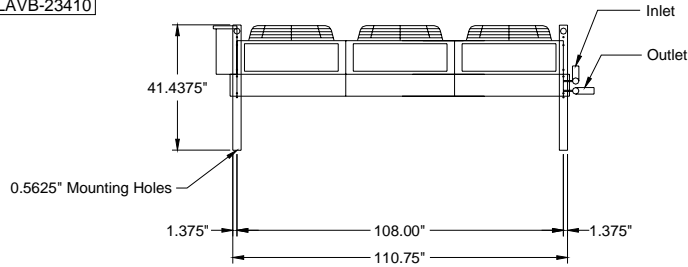

LAVB-24310

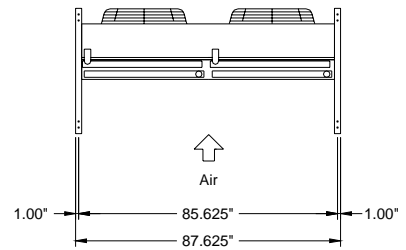
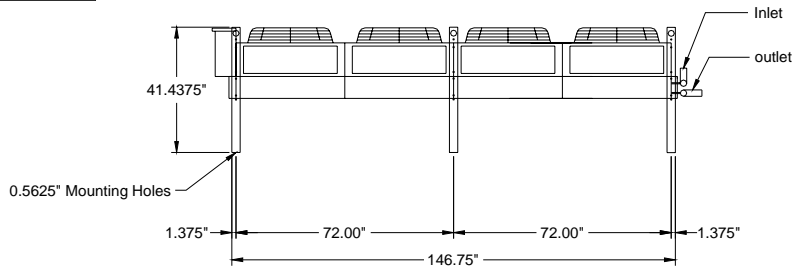

Model	Chiller Model Used With	Refrigerant Type	Condenser Air Flow CFM	Connection Size (inch)		Condenser Fans		Unit MCA @ 460/3/60 ¹	Shipping Weight Lbs.
				Inlet	Outlet	Qty	HP Each		
LAVB22310	TSR20A	HCFC-22	25,600	1 5/8	1 3/8	4	1/2	9	865
LAVB23310	TSR30A	HCFC-22	38,400	2 1/4	1 5/8	6	1/2	13	1,120
LAVB23410	TSR40A	HCFC-22	36,000	2 5/8	2 1/4	6	1/2	13	1,225
LAVB24310	TSR50A	HCFC-22	51,200	2 5/8	2 1/4	8	1/2	18	1,705

¹MCA (Minimum Circuit Ampacity) is 125% of the largest fan FLA plus 100% of all remaining fan FLAs.

Remote Condensers For TSR60A – TSR100A Remote Air-Cooled Chillers

www.DataSheet4U.com

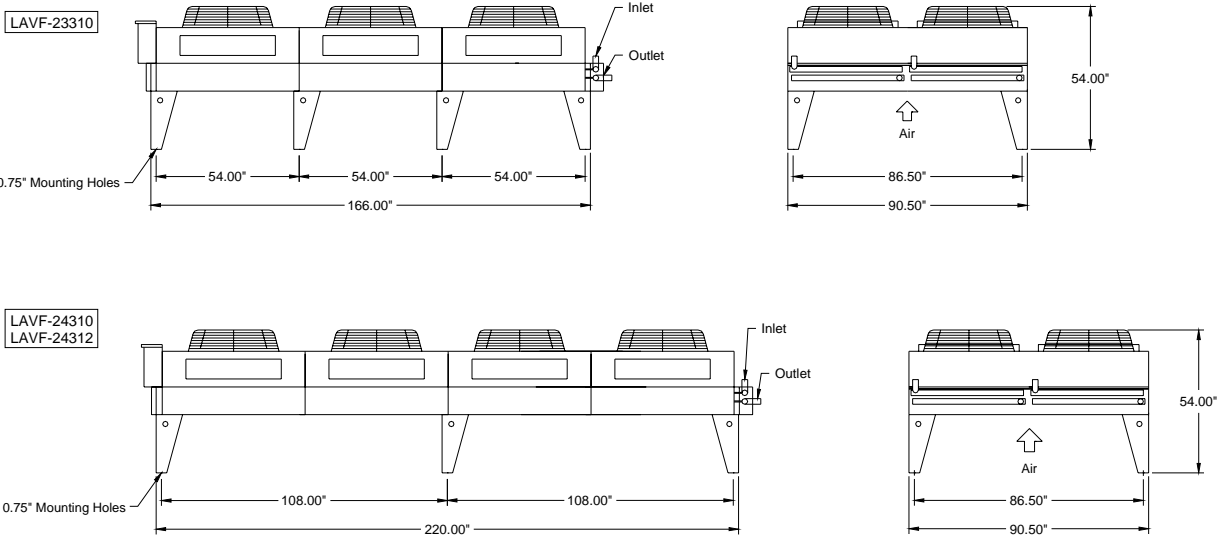

Model	Chiller Model Used With	Refrigerant Type	Condenser Air Flow CFM	Connection Size (inch)		Condenser Fans		Unit MCA @ 460/3/60 ¹	Shipping Weight Lbs.
				Inlet	Outlet	Qty	HP Each		
LAVF23310	TSR60A	HCFC-22	65,045	2 5/8	2 1/4	6	1/2	13	2,065
LAVF24310	TSR80A	HCFC-22	86,730	2 5/8	2 5/8	8	1/2	18	2,655
LAVF24312	TSR100A	HCFC-22	84,690	2 5/8	2 5/8	8	1/2	18	2,700

¹MCA (Minimum Circuit Ampacity) is 125% of the largest fan FLA plus 100% of all remaining fan FLAs.

Reservoir System Pumps

60 Hz Pump Curves for Water

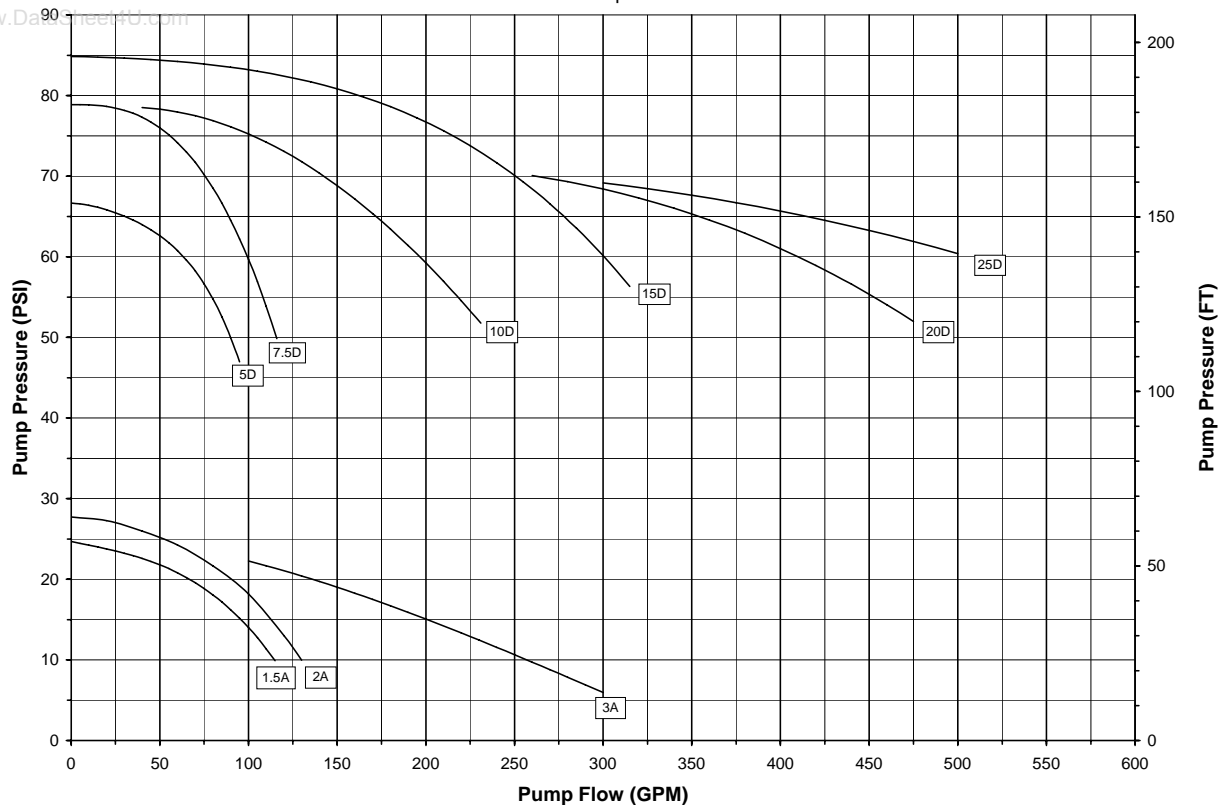

Chiller Model	Standard Flow Pump Set (2.4 GPM / ton to process)		Double Flow Pump Set (4.8 GPM / ton to process)	
	Process Pump 2.4 GPM / ton	Chiller Pump 2.4 GPM / ton	Process Pump 4.8 GPM / ton	Chiller Pump 2.4 GPM / ton
TSW20A & TSR20A	5D	1.5A	10D	1.5A
TSW30A & TSR30A	7.5D	2A	10D	2A
TSW40A & TSR40A	10D	2A	15D	2A
TSW50A & TSR50A	10D	3A	15D	3A
TSW60A & TSR60A	10D	3A	20D	3A
TSW80A & TSR80A	15D	3A	25D	3A
TSW100A & TSR100A	15D	3A	25D	3A



7720 North Lehigh Avenue
 Niles, Illinois 60714-3491
 Tel: (847) 929-1950
 Toll Free: (800) 297-6861
 Fax: (847) 966-9358

Email: info@awsintl.com
 Website: www.awsintl.com

Manufacturer reserves the right to change specifications or design without notice or obligation. AWS is a Division of Thermal Care. Thermal Care is a registered trademark of MFRI, Inc.