

# TSD65R700S1/TSU65R700S1

## 650V 7A N-Channel SJ-MOSFET

### General Description

Truesemi SJ-FET is new generation of high voltage MOSFET family that is utilizing an advanced charge balance mechanism for outstanding low on-resistance and lower gate charge performance. This advanced technology has been tailored to minimize conduction loss, provide superior switching performance, and withstand extreme  $dv/dt$  rate and higher avalanche energy. SJ-FET is suitable for various AC/DC power conversion in switching mode operation for higher efficiency.

### Features

- 700V @  $T_J = 150^\circ\text{C}$
- Typ.  $R_{DS(on)} = 0.6\Omega$
- Ultra Low gate charge (typ.  $Q_g = 25\text{nC}$ )
- 100% avalanche tested

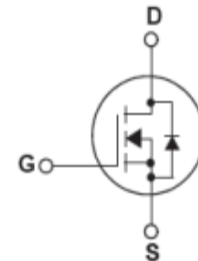
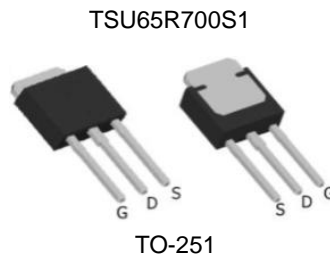
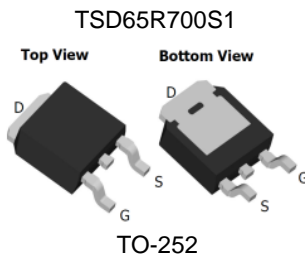

### Absolute Maximum Ratings

Symbol	Parameter	TSD65R700S1	TSU65R700S1	Unit
$V_{DSS}$	Drain-Source Voltage	650		V
$I_D$	Drain Current -Continuous ( $T_C = 25^\circ\text{C}$ ) -Continuous ( $T_C = 100^\circ\text{C}$ )	7*		A
		4.6*		
$I_{DM}$	Drain Current – Pulsed (Note 1)	18*	18	A
$V_{GSS}$	Gate-Source voltage	$\pm 30$		V
$E_{AS}$	Single Pulsed Avalanche Energy (Note 2)	86		mJ
$I_{AR}$	Avalanche Current (Note 1)	1.7		A
$E_{AR}$	Repetitive Avalanche Energy (Note 1)	0.2		mJ
$dv/dt$	Peak Diode Recovery $dv/dt$ (Note 3)	15		V/ns
$P_D$	Power Dissipation ( $T_C = 25^\circ\text{C}$ ) -Derate above $25^\circ\text{C}$	63	63	W
		0.3	1.67	
$T_J, T_{STG}$	Operating and Storage Temperature Range	-55 to +150		$^\circ\text{C}$
$T_L$	Maximum Lead Temperature for Soldering Purpose, 1/8" from Case for 5 Seconds	300		$^\circ\text{C}$

\* Drain current limited by maximum junction temperature.

### Thermal Characteristics

Symbol	Parameter	Value	Unit
$R_{\theta JC}$	Thermal Resistance, Junction-to-Case	2.0	$^\circ\text{C/W}$
$R_{\theta CS}$	Thermal Resistance, Case-to-Sink Typ.	0.5	$^\circ\text{C/W}$
$R_{\theta JA}$	Thermal Resistance, Junction-to-Ambient	62	$^\circ\text{C/W}$

## Electrical Characteristics TC = 25 °C unless otherwise noted

Symbol	Parameter	Conditions	Min	Typ	Max	Unit
Off Characteristics						
BV <sub>DSS</sub>	Drain-Source Breakdown Voltage	V <sub>GS</sub> = 0V, I <sub>D</sub> = 250μA, T <sub>J</sub> = 25 °C	650	--	--	V
		V <sub>GS</sub> = 0V, I <sub>D</sub> = 250μA, T <sub>J</sub> = 150 °C	--	700	--	V
ΔBV <sub>DSS</sub> / ΔT <sub>J</sub>	Breakdown Voltage Temperature Coefficient	I <sub>D</sub> = 250μA, Referenced to 25 °C	--	0.6	--	V/°C
I <sub>DSS</sub>	Zero Gate Voltage Drain Current	V <sub>DS</sub> = 650V, V <sub>GS</sub> = 0V -T <sub>J</sub> = 125 °C	--	--	1 10	μA μA
I <sub>GSSF</sub>	Gate-Body Leakage Current, Forward	V <sub>GS</sub> = 30V, V <sub>DS</sub> = 0V	--	--	100	nA
I <sub>GSSR</sub>	Gate-Body Leakage Current, Reverse	V <sub>GS</sub> = -30V, V <sub>DS</sub> = 0V	--	--	-100	nA
On Characteristics						
V <sub>GS(th)</sub>	Gate Threshold Voltage	V <sub>DS</sub> = V <sub>GS</sub> , I <sub>D</sub> = 250μA	2.5	3.5	4.5	V
R <sub>DS(on)</sub>	Static Drain-Source On-Resistance	V <sub>GS</sub> = 10V, I <sub>D</sub> = 3.5A	--	0.6	0.7	Ω
g <sub>FS</sub>	Forward Trans conductance	V <sub>DS</sub> = 40V, I <sub>D</sub> = 3.5A (Note 4)	--	16	--	S
Dynamic Characteristics						
C <sub>iss</sub>	Input Capacitance	V <sub>DS</sub> = 25V, V <sub>GS</sub> = 0V, f = 1.0MHz	--	380	--	pF
C <sub>oss</sub>	Output Capacitance		--	110	--	pF
C <sub>rss</sub>	Reverse Transfer Capacitance		--	7	--	pF
Switching Characteristics						
t <sub>d(on)</sub>	Turn-On Delay Time	V <sub>DD</sub> = 400V, I <sub>D</sub> = 3.5A R <sub>G</sub> = 20Ω (Note 4, 5)	--	13	--	ns
t <sub>r</sub>	Turn-On Rise Time		--	10	--	ns
t <sub>d(off)</sub>	Turn-Off Delay Time		--	85	--	ns
t <sub>f</sub>	Turn-Off Fall Time		--	14	--	ns
Q <sub>g</sub>	Total Gate Charge	V <sub>DS</sub> = 480V, I <sub>D</sub> = 3.5A V <sub>GS</sub> = 10V (Note 4, 5)	--	25	--	nC
Q <sub>gs</sub>	Gate-Source Charge		--	2.0	--	nC
Q <sub>gd</sub>	Gate-Drain Charge		--	2.7	--	nC
Drain-Source Diode Characteristics and Maximum Ratings						
I <sub>S</sub>	Maximum Continuous Drain-Source Diode Forward Current		--	--	7	A
I <sub>SM</sub>	Maximum Pulsed Drain-Source Diode Forward Current		--	--	18	A
V <sub>SD</sub>	Drain-Source Diode Forward Voltage	V <sub>GS</sub> = 0V, I <sub>F</sub> = 3.5A	--	0.9	1.5	V
t <sub>rr</sub>	Reverse Recovery Time	V <sub>GS</sub> = 0V, I <sub>F</sub> = 3.5A di <sub>F</sub> /dt = 100A/μs (Note 4)	--	190	--	ns
Q <sub>rr</sub>	Reverse Recovery Charge		--	2.3	--	μC

## NOTES:

1. Repetitive Rating: Pulse width limited by maximum junction temperature
2. L = 60mH, I<sub>AS</sub> = 1.7A, V<sub>DD</sub> = 50V, Starting T<sub>J</sub> = 25 °C
3. I<sub>SD</sub> ≤ 7A, di/dt ≤ 200A/us, V<sub>DD</sub> ≤ BV<sub>DSS</sub>, Starting T<sub>J</sub> = 25 °C
4. Pulse Test: Pulse width ≤ 300us, Duty Cycle ≤ 2%
5. Essentially Independent of Operating Temperature Typical Characteristics

# Typical Performance Characteristics

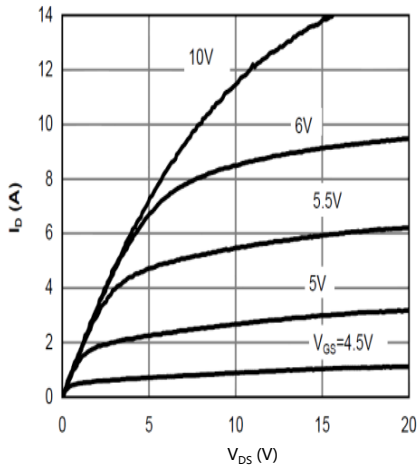

Figure 1: On-Region Characteristics@25°C

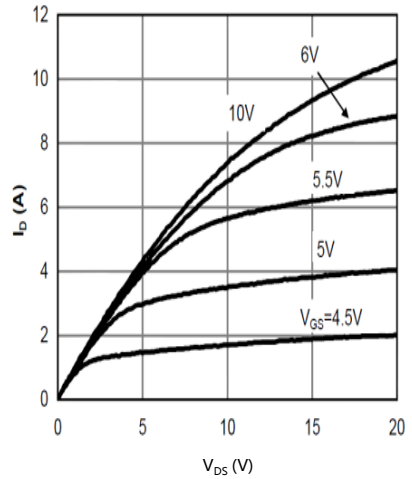

Figure 2: On-Region Characteristics@125°C

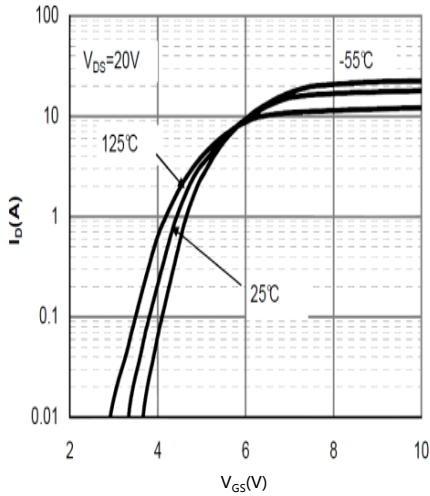

Figure 3: Typ. transfer characteristics

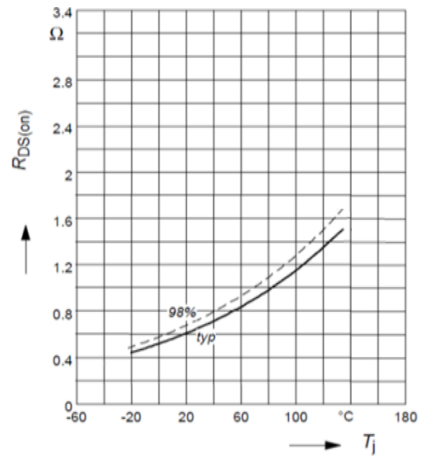

Figure 4: On-Resistance vs. Junction Temperature

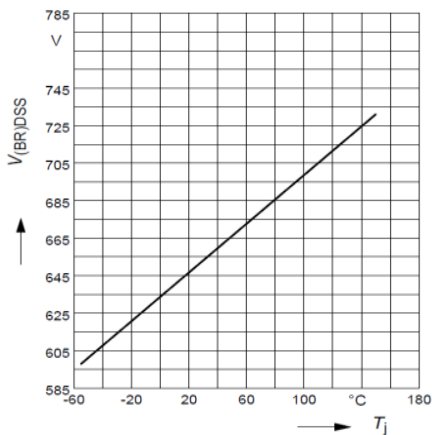

Figure 5: Break Down vs. Junction Temperature

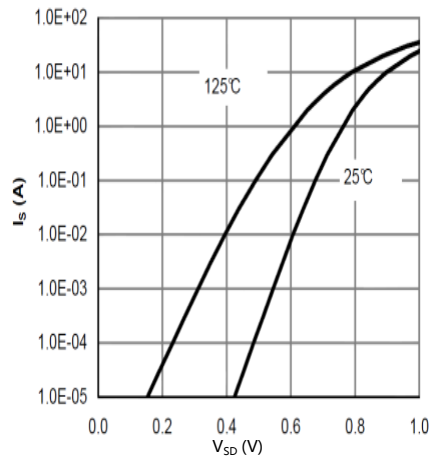

Figure 6: Body-Diode Characteristics

# Typical Performance Characteristics

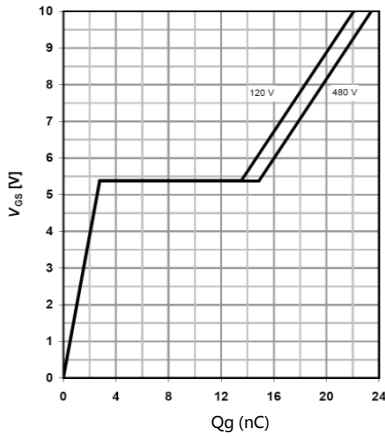

Figure 7: Gate-Charge Characteristics

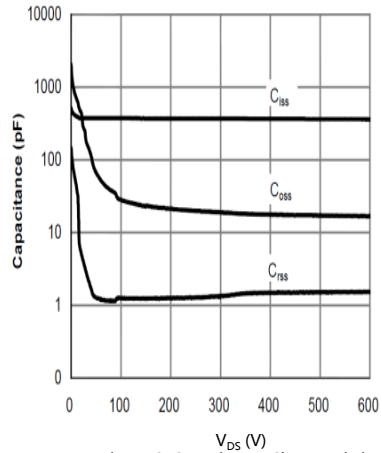

Figure 8: Capacitance Characteristics

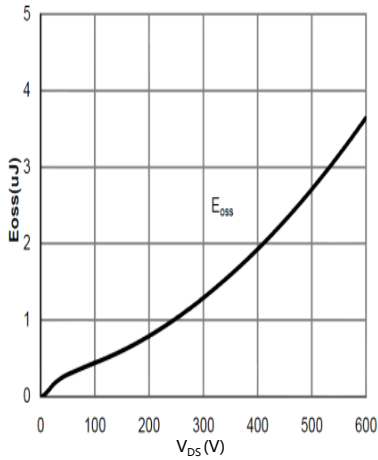

Figure 9:  $C_{oss}$  stored Energy

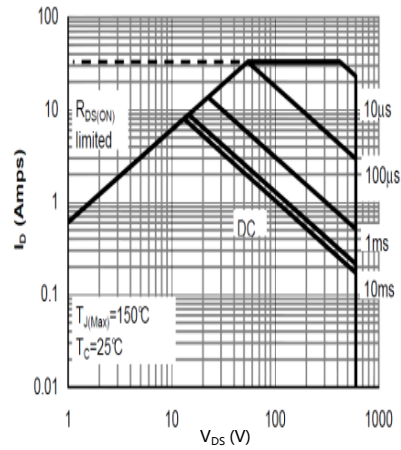

Figure 10: Maximum Forward Biased Safe Operating Area  $T_c=25^\circ\text{C}$ ,

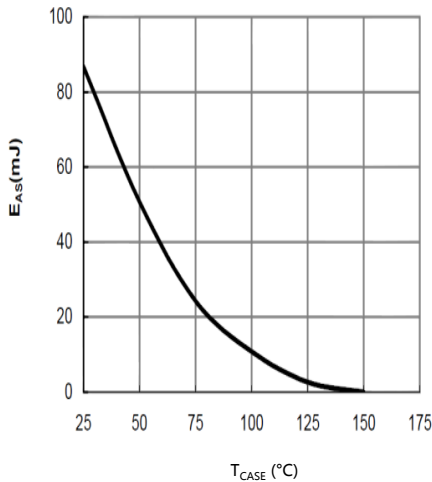

Figure 11: Avalanche energy

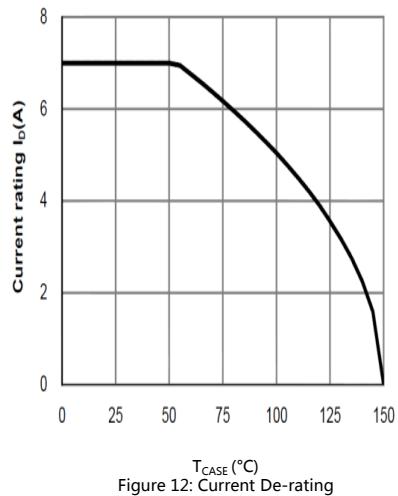

Figure 12: Current De-rating

# Typical Performance Characteristics

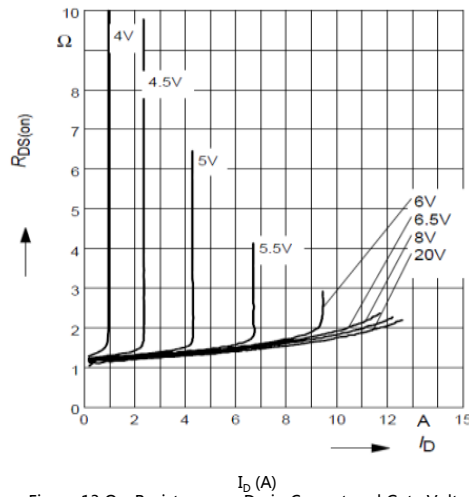

Figure 13 On-Resistance vs. Drain Current and Gate Voltage

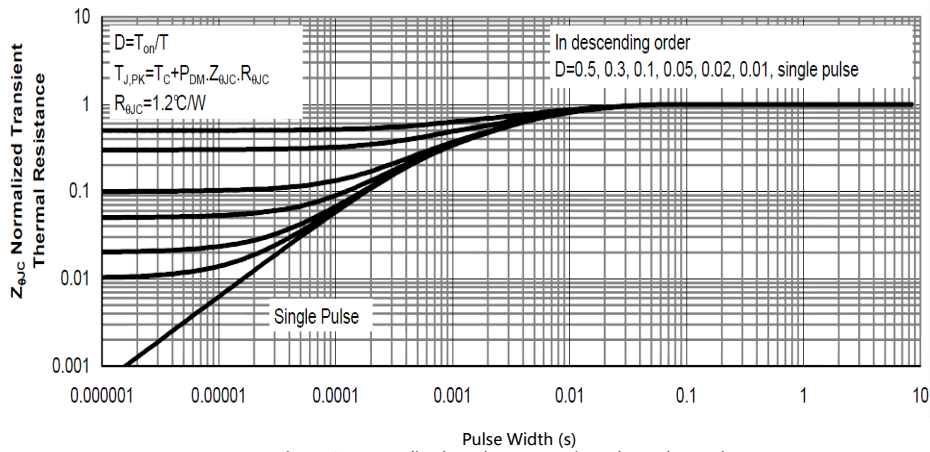

Figure 14: Normalized Maximum Transient Thermal Impedance

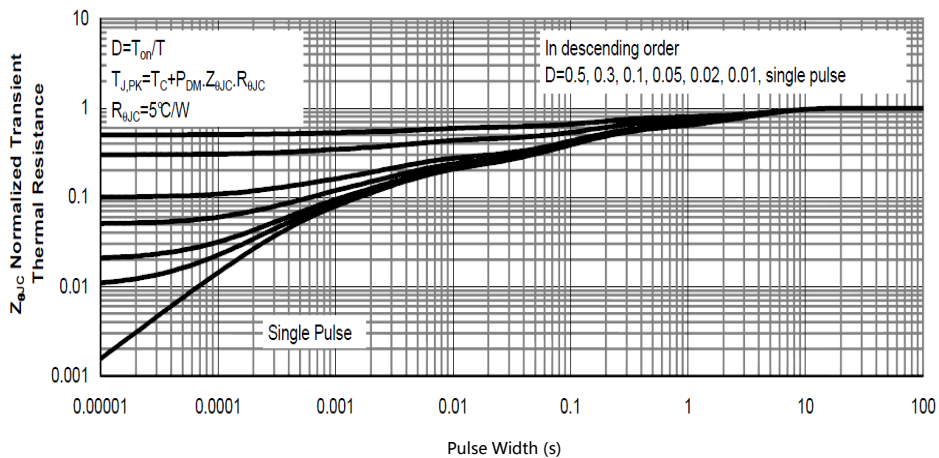
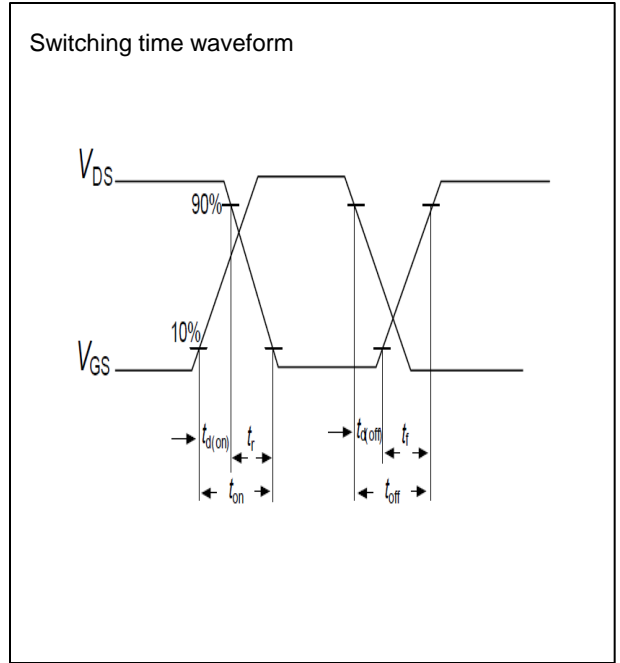
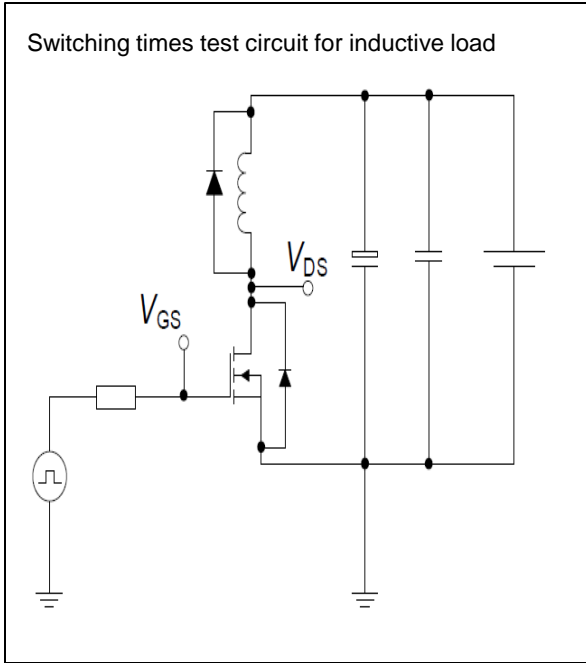

Figure 15: Normalized Maximum Transient Thermal Impedance

# Test circuits

## Switching times test circuit and waveform for inductive load



## Unclamped inductive load test circuit and waveform

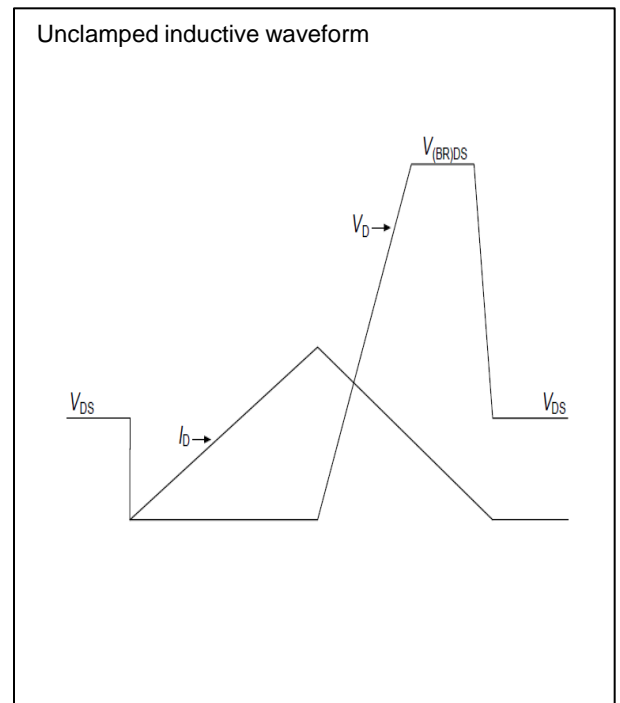
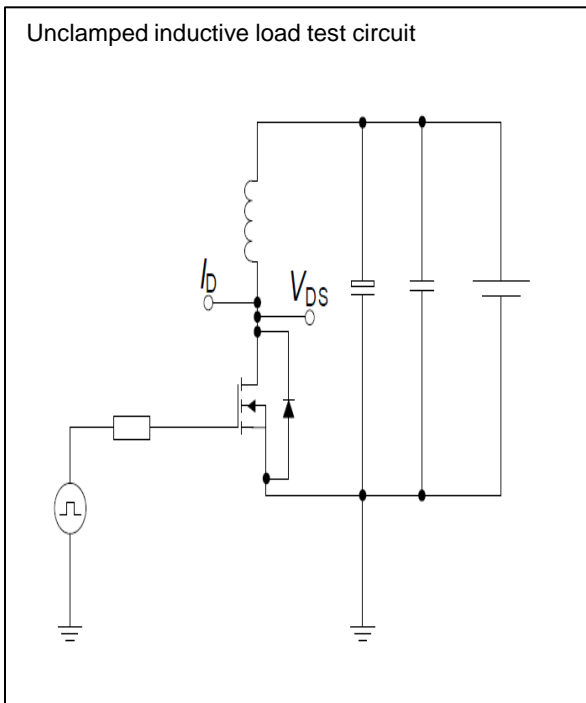

# Test circuits

## Test circuit and waveform for diode characteristics

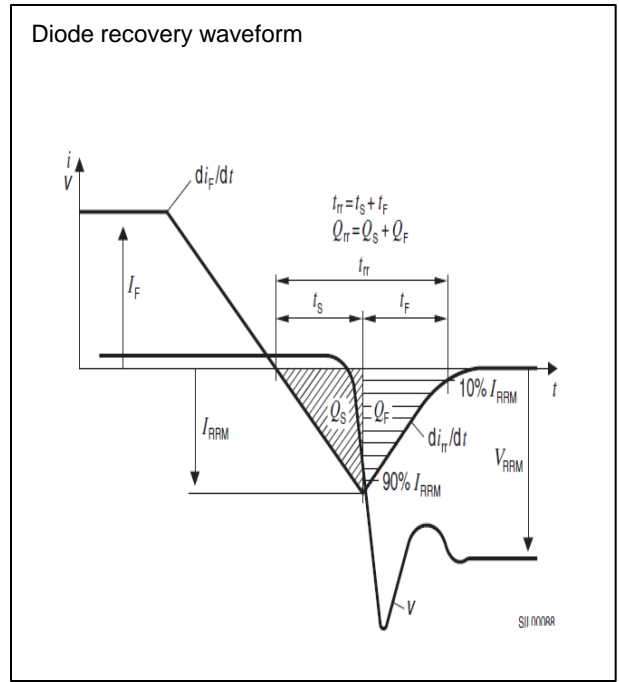
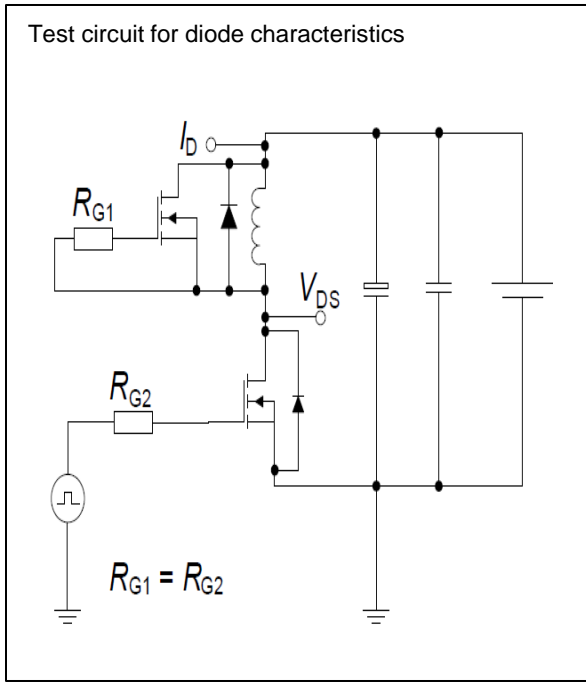

# Package Outline TO-252

TSD65R700S1/TSU65R700S1 650V 7A N-Channel SJ-MOSFET

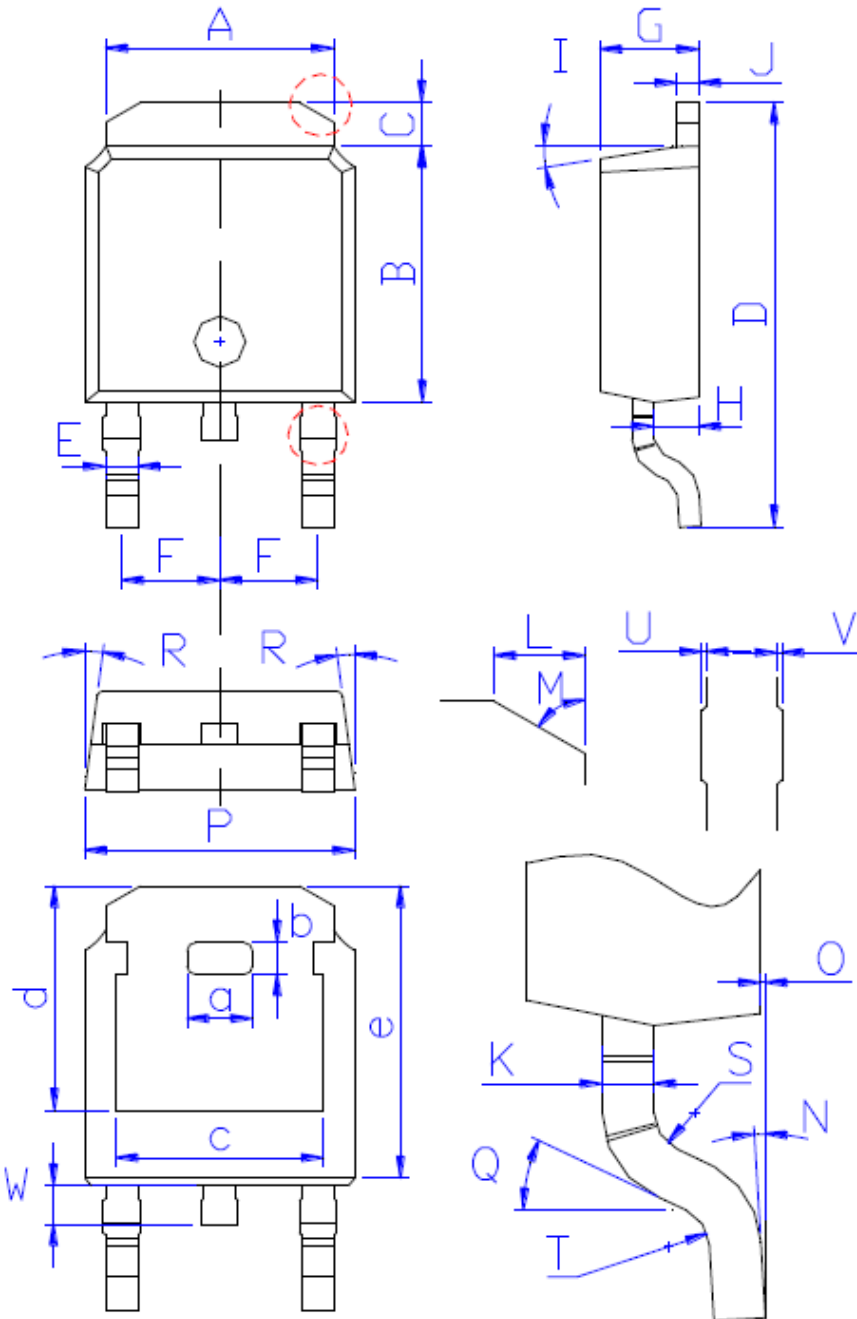

DIM	MILLIMETERS
A	$5.34 \pm 0.30$
B	$6.00 \pm 0.30$
C	$1.05 \pm 0.30$
D	$9.95 \pm 0.30$
E	$0.76 \pm 0.15$
F	$2.28 \pm 0.15$
G	$2.30 \pm 0.30$
H	$1.06 \pm 0.30$
I	$(4-10)^\circ$
J	$0.51 \pm 0.15$
K	$0.52 \pm 0.15$
L	$0.80 \pm 0.30$
M	$60^\circ$
N	$(0-10)^\circ$
O	$0.05 \pm 0.05$
P	$6.60 \pm 0.30$
Q	$25^\circ$
R	$(4-8.5)^\circ$
S	R0.40
T	R0.40
U	$0.05 \pm 0.05$
V	$0.05 \pm 0.05$
W	$0.90 \pm 0.30$
a	$1.80 \pm 0.30$
b	$0.75 \pm 0.30$
c	$4.85 \pm 0.30$
d	$5.30 \pm 0.30$
e	$6.90 \pm 0.30$



# Package Outline TO-251

TSD65R700S1/TSU65R700S1 650V 7A N-Channel SJ-MOSFET

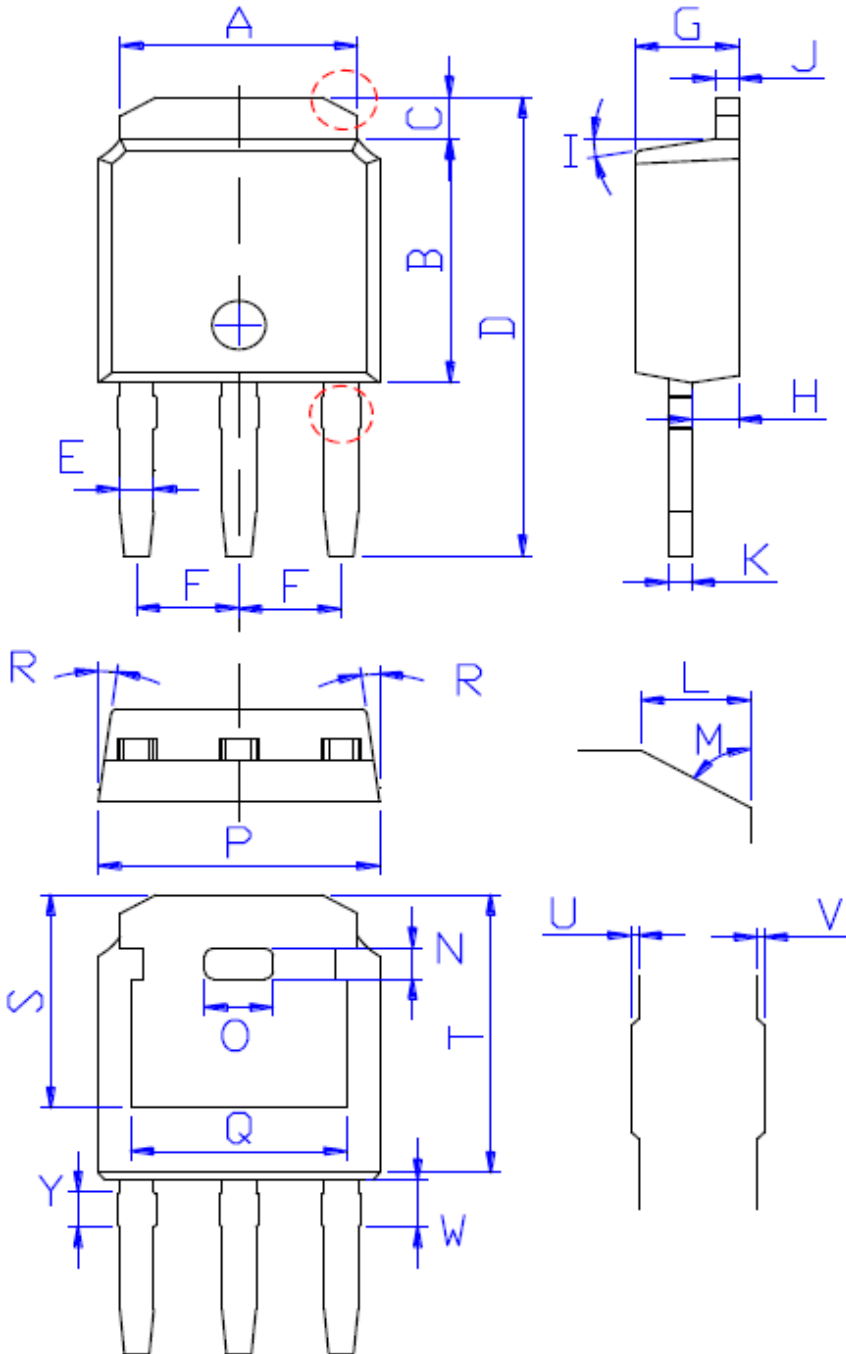

DIM	MILLIMETERS
A	5.34±0.30
B	6.00±0.30
C	1.05±0.30
D	11.31±0.30
E	0.76±0.15
F	2.28±0.15
G	2.30±0.30
H	1.06±0.30
I	(4-10)°
J	0.51±0.15
K	0.52±0.15
L	0.80±0.30
M	60°
N	0.75±0.30
O	1.80±0.30
P	6.60±0.30
Q	4.85±0.30
R	(4-8.5)°
S	5.30±0.30
T	6.90±0.30
U	0.05±0.05
V	0.05±0.05
W	1.15±0.25
Y	0.85±0.25