TW2835

4 Channel Video and Audio Controller

For Security Applications

Preliminary Data Sheet from Techwell, Inc.

Information may change without notice

Disclaimer

This document provides technical information for the user. Techwell Inc. reserves the right to modify the information in this document as necessary. The customer should make sure that they have the most recent data sheet version. Techwell Inc. holds no responsibility for any errors that may appear in this document. Customers should take appropriate action to ensure their use of the products does not infringe upon any patents. Techwell Inc. respects valid patent rights of third parties and does not infringe upon or assist others to infringe upon such rights.

Table of Contents

Introduction	5
Features	5
Applications	6
Block Diagram	7
Pin Description	8
Pin Diagram	15
Functional Description	17
Video Input	17
Analog Video Input.....	18
Anti-aliasing Filter.....	19
Analog-to-Digital Converter.....	19
Sync Processing.....	20
Color Decoding.....	21
Luminance Processing.....	23
Chrominance Processing.....	24
Realtime Record Mode.....	25
Digital Video Input.....	26
Digital Video Input Format.....	26
Channel ID Decoder.....	27
Cropping and Scaling Function.....	29
Cropping Function for Live.....	29
Scaling Function for Live.....	30
Cropping and Scaling Function for Playback.....	34
Motion Detection	36
Mask and Detection Region Selection.....	37
Sensitivity Control.....	38
Level Sensitivity.....	38
Spatial Sensitivity.....	38
Temporal Sensitivity.....	38
Velocity Control.....	39
Blind Detection.....	41
Night Detection.....	41
Video Control	42
Channel Input Selection.....	43
Channel Operation Mode.....	44

Live Mode	44
Strobe Mode	45
Switch Mode.....	47
Channel Attribute	51
Background Control	51
Boundary Control	51
Blank Control	51
Freeze Control	51
Last Image Captured	52
Horizontal / Vertical Mirroring	52
Field to Frame Conversion	52
Display Path Control	53
Save and Recall Function	53
Image Enhancement	54
Zoom Function	54
Picture Size and Popup Control.....	55
Full Triplex Function.....	56
Playback Path Control	57
Frame Record Mode	59
DVR Normal Record Mode.....	61
DVR Frame Record Mode.....	62
Record Path Control	64
Normal Record Mode	65
Frame Record Mode	66
DVR Normal Record Mode.....	67
DVR Frame Record Mode.....	68
Noise Reduction	69
Channel ID Encoder	70
Channel ID Information	70
Analog Type Channel ID in VBI.....	73
Digital Type Channel ID in VBI	74
Digital Type Channel ID in Channel Boundary	75
Chip-to-Chip Cascade Operation	76
Channel Priority Control	76
120 CIF/Sec Record Mode	78
240 CIF/Sec Record Mode	79
480 CIF/Sec Record Mode	80
Infinite Cascade Mode for Display Path	81
OSD (On Screen Display) Control.....	82
2 Dimensional Arrayed Box.....	83
Bitmap Overlay	85

Single Box	89
Mouse Pointer.....	89
Video Output	90
Timing Interface and Control	91
Analog Video Output	93
Output Standard Selection.....	93
Luminance Filter	94
Chrominance Filter.....	94
Digital-to-Analog Converter	95
Digital Video Output.....	96
Single Output Mode	97
Dual Output Mode.....	98
Audio CODEC	99
Multi-Chip Operation	100
Serial Audio Interface	102
Analog Audio Output	105
Host Interface.....	106
Serial Interface	107
Parallel Interface	109
Interrupt Interface	111
MPP Pin Interface.....	112
Control Register	113
Register Map	113
Recommended Value.....	122
Register Description.....	127
Parametric Information	247
DC Electrical Parameters	247
AC Electrical Parameters	249
Application Schematic	253
Package Dimension.....	254
Revision History	256

Introduction

The TW2835 has four high quality NTSC/PAL video decoders, dual color display controllers and dual video encoders. The TW2835 contains four built-in analog anti-aliasing filters, four 10bit Analog-to-Digital converters, and proprietary digital gain/clamp controller, high quality Y/C separator to reduce cross-noise and high performance free scaler. Four built-in motion, blind and night detectors can increase the feature of security system. The TW2835 has flexible video display/record/playback controller including basic display and MUX functions. The TW2835 also has excellent graphic overlay function that displays bitmap for OSD, single box, 2D array box, and mouse pointer. The built-in channel ID CODEC allows auto decoding and displaying during playback and the additional scaler on the playback supports multi-cropping function of the same field or frame image. The TW2835 contains two video encoders with three 10bit Digital-to-Analog converters to provide 2 composite or S-video. The TW2835 also includes audio CODEC that has four audio Analog-to-Digital converters and one Digital-to-Analog converter. A built-in audio controller can generate digital outputs for recording/mixing and accepts digital input for playback. The TW2835 can be extended up to 8/16 channel video controller using chip-to-chip cascade connection.

Features

Four Video Decoders

- Accepts all NTSC(M/N/4.43) / PAL(B/D/G/H/I/K/L/M/N/60) standards with auto detection
- Integrated four video analog anti-aliasing filters and 10 bit CMOS ADCs
- High performance adaptive 4H comb filters for all NTSC/PAL standards
- IF compensation filter for improvement of color demodulation
- Color Transient Improvement (CTI)
- Automatic white peak control
- Programmable hue, saturation, contrast, brightness and sharpness
- High performance horizontal and vertical scaler for each path including playback input
- Fast video locking system for non-realtime application
- Four built-in motion detectors with 16X12 cells and blind and night detectors
- Additional digital input for playback with ITU-R BT.656 standard
- Auto cropping / strobe for playback input with Channel ID decoder
- Supports four channel full D1 record mode

Dual Video Controllers

- Support full triplex function with 4ch live, 4ch playback display and 4ch record output
- Analog/Digital channel ID CODEC for record and playback application
- Support adaptive median filter for Record
- Supports pseudo 8 channel and/or dual page mode

- Horizontal/Vertical mirroring for each channel
- Last image captured when video-loss detected
- Auto sequence switch with 128 queues and/or manual switch by interrupt for record path
- Channel skip in auto sequence switch for record path when video-loss detected
- Image enhancement for zoomed or still image in display path
- High performance 2X zoom to horizontal and vertical direction for display path
- Extendable up to 8/16 channel video controller using cascade connection
- Quad MUX switch with 32 queues and/or manual control by interrupt for record path
- 64 color bitmap OSD overlay with 720x480 in NTSC / 720x588 resolution in PAL
- Four programmable single boxes and four 2D arrayed boxes overlay
- Mouse pointer overlay

Dual Video Encoders

- Dual path digital outputs with ITU-R BT.656 standard
- Dual path analog outputs with all analog NTSC/PAL standards
- Programmable bandwidth of luminance and chrominance signal for each path
- Three 10bit video CMOS DACs

Audio CODEC

- Integrated four audio ADCs and one audio DAC
- Provides multi-channel audio mixed analog output
- Supports a standard I2S interface for record output and playback input
- 8/16 bit audio word length
- Sample audio with 8/16KHz

Applications

- Analog QUAD/MUX System
- 4/8/16 Channel DVR System
- Car Rear Vision System
- Hair Shop System
- Dental Care System

Block Diagram

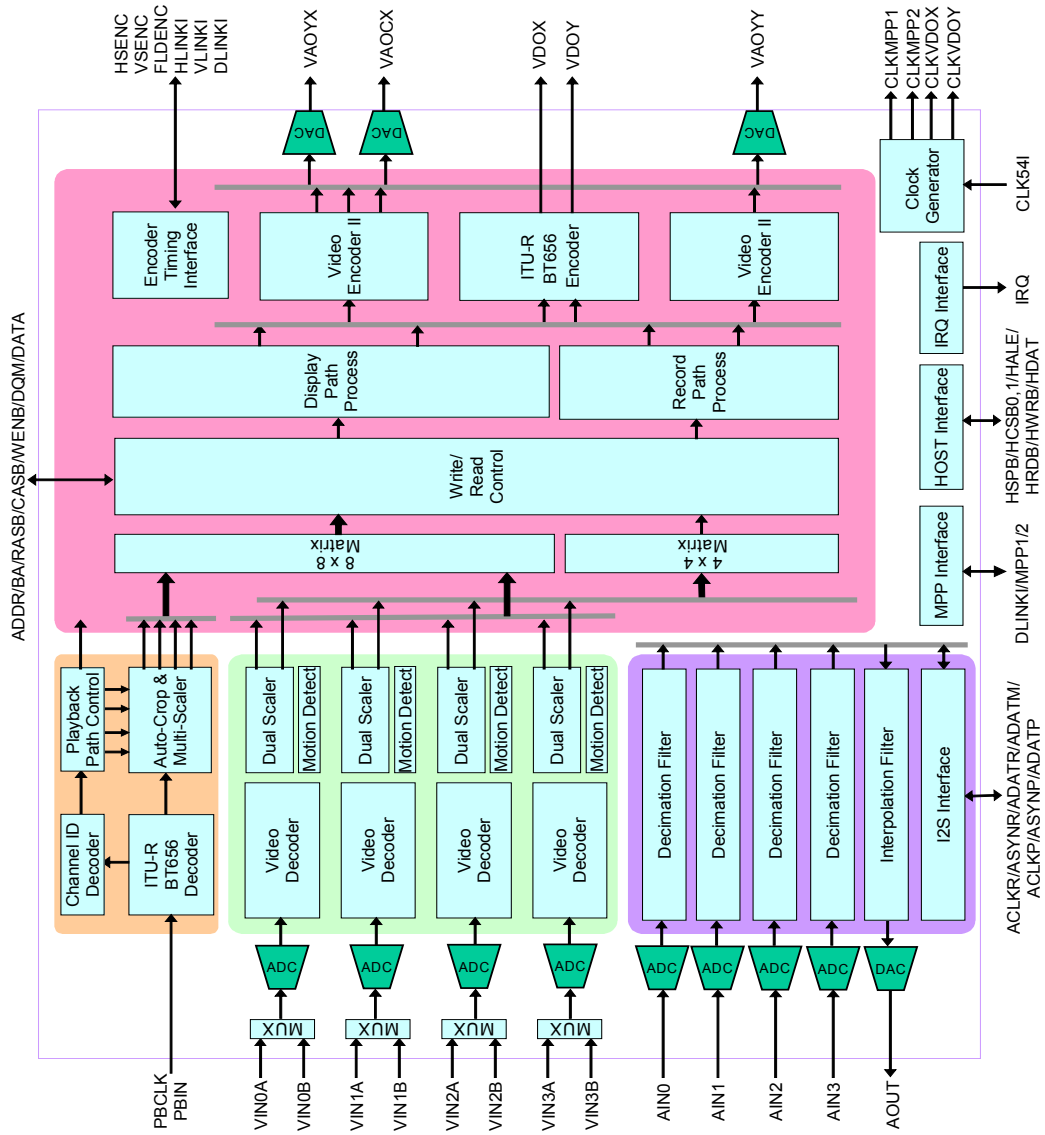

Pin Description

Analog Interface Pins

Name	Number		Type	Description
	<i>QFP</i>	<i>LBGA</i>		
VIN0A	166	B12	A	Composite video input A of channel 0.
VIN0B	167	C12	A	Composite video input B of channel 0.
VIN1A	170	B11	A	Composite video input A of channel 1.
VIN1B	171	C11	A	Composite video input B of channel 1.
VIN2A	176	B10	A	Composite video input A of channel 2.
VIN2B	177	C10	A	Composite video input B of channel 2.
VIN3A	180	B9	A	Composite video input A of channel 3.
VIN3B	181	C9	A	Composite video input B of channel 3.
VAOYX	184	C8	A	Analog video output.
VAOCX	186	D8	A	Analog video output.
VAOYY	189	C7	A	Analog video output.
NC	191	D7	A	No connection.
AIN0	197	B6	A	Audio input of channel 0.
AIN1	198	C6	A	Audio input of channel 1.
AIN2	199	B5	A	Audio input of channel 2.
AIN3	200	C5	A	Audio input of channel 3.
AOUT	194	D5	A	Audio mixing output.

Digital Video Interface Pins

Name	Number		Type	Description
	QFP	LBGA		
VDOX [7:0]	8,9, 10,11, 13,14, 15,16	C1,C2, D2,D3, E1,E2, E3,E4	O	Digital video data output for display path. Or link signal for multi-chip connection.
VDOY [7:0]	33,34, 36,37, 38,39, 40,42	J4,K2, K3,L1, L2,L3, L4,M1	O	Digital video data output for record path.
CLKVDOX	17	F1	O	Clock output for VDOUTX.
CLKVDOY	32	J3	O	Clock output for VDOUTY..
HSENC	21	F4	O	Encoder horizontal sync.
VSENC	20	F3	O	Encoder vertical sync. Or link signal for multi-chip connection.
FLDENC	19	F2	O	Encoder field flag.
PBDIN[7:0]	43,44, 45,46, 48,49, 50,51	M2,M3, M4,N2, N3,P1, P2,R1	I	Video data of playback input.
PBCLK	54	R2	I	Clock of playback input.

Multi-purpose Pins

Name	Number		Type	Description
	QFP	LPGA		
HLINKI	138	F14	I/O	Link signal for multi-chip connection.
VLINKI	140	F13	I	Link signal for multi-chip connection.
DLINKI[7:0]	149,148, 147,146, 144,143, 142,141	C15,C16, D14,D15, E13,E14, E15,E16	I/O	Link signal for multi-chip connection. Or decoder's bypassed data output. Or decoder's timing signal output. Or general purpose input/output.
MPP1[7:0]	204,205, 206,207, 2,3, 4,5	A4,B4, C4,A3, B3,C3, A2,B2	I/O	Decoder's bypassed data output. Or decoder's timing signal output. Or general purpose input/output.
MPP2[7:0]	152,153, 154,155, 158,159, 160,161	B16,B15, A15,A14, B14,A13, B13,C13	I/O	Decoder's bypassed data output. Or decoder's timing signal output. Or general purpose input/output.
CLKMPP1	7	B1	O	Clock output for MPP1 data.
CLKMPP2	150	C14	O	Clock output for MPP2 data.

Digital Audio Interface Pins

Name	Number		Type	Description
	<i>QFP</i>	<i>LBGA</i>		
ACLKR	27	H3	O	Audio serial clock output of record.
ASYNR	26	H2	O	Audio serial sync output of record.
ADATR	25	H1	O	Audio serial data output of record.
ADATM	23	G3	O	Audio serial data output of mixing.
ACLKP	31	J2	I/O	Audio serial clock input/output of playback.
ASYNP	30	J1	I/O	Audio serial sync input/output of playback.
ADATP	28	H4	I	Audio serial data input of playback.
ALINKI	137	F15	I	Link signal for multi-chip connection.
ALINKO	22	G2	O	Link signal for multi-chip connection.

Memory Interface Pins

Name	Number		Type	Description
	QFP	LBGA		
DATA[31:0]	76,77, 78,79, 80,82, 83,84, 85,86, 88,89, 90,91, 92,94, 118,119, 120,121, 123,124, 125,126, 127,129, 130,131, 132,134, 135,136	R8,P8, N8,T9, R9,P9, N9,R10, P10,T11, R11,P11, N11,T12, R12,P12, L15,L14, L13,K15, K14,J16, J15,J14, J13,H16, H15,H14, H13,G15, G14,F16	I/O	SDRAM data bus.
ADDR[10:0]	95,96, 97,98, 100,101, 102,103, 106,107, 108	N12,R13, P13,T14, R14,P14, T15,R15, R16,P16, P15	O	SDRAM address bus. ADDR[10] is AP.
BA1	109	N15	O	SDRAM bank1 selection.
BA0	111	N14	O	SDRAM bank0 selection.
RASB	113	M15	O	SDRAM row address selection.
CASB	114	M14	O	SDRAM column address selection.
WEB	115	M13	O	SDRAM write enable.
DQM	117	L16	O	SDRAM write mask.
CLK54MEM	112	M16	O	SDRAM clock.

System Control Pins

Name	Number		Type	Description
	QFP	LBGA		
TEST	164	D12	I	Only for the test purpose. Must be connected to VSSO.
RSTB	73	P7	I	System reset. Active low.
IRQ	72	R7	O	Interrupt request signal.
HDAT[7:0]	62,63, 65,66, 67,68, 69,71	T5,R5, P5,N5, T6,R6, P6,N6	I/O	Data bus for parallel interface. HDAT[7] is serial data for serial interface. HDAT[6:1] is slave address[6:1] for serial interface.
HWRB	61	P4	I	Write enable for parallel interface. VSSO for serial interface.
HRDB	60	R4	I	Read enable for parallel interface. VSSO for serial interface.
HALE	59	P3	I	Address line enable for parallel interface. Serial clock for serial interface.
HCSB1	57	R3	I	Chip select 1 for parallel interface. VSSO for serial interface.
HCSB0	56	T3	I	Chip select 0 for parallel interface. Slave address[0] for serial interface.
HSPB	55	T2	I	Select serial/parallel host interface.
CLK54I	74	T8	I	54MHz system clock.

Power / Ground Pins

Name	Number		Type	Description
	QFP	LBGA		
VDDO	18,47, 64,93, 110,139, 157,208	A1,A16, K1,K16, T1,T7, T10,T16	P	Digital power for output driver 3.3V.
VDDI	6,24, 41,58, 99,116, 133,151,	D1,D16, G1,G16, N1,N16, T4,T13	P	Digital power for internal logic 1.8V.
VDDVADC	165,172, 173,175, 182	A8,A9, A10,A11, A12	P	Analog power for Video ADC 1.8V.
VSSVADC	168,169, 174,178, 179	D10,D11, D13, E11, E12	G	Analog ground for Video ADC 1.8V.
VDDVDAC	185,187, 190	A7,B7, B8	P	Analog power for Video DAC 1.8V.
VSSVDAC	183,188, 192	D9,E7, E8,E9, E10	G	Analog ground for Video DAC 1.8V.
VDDAADAC	201	A6	P	Analog power for Audio ADC 1.8V.
VSSAADAC	196	D6,E6	G	Analog ground for Audio ADC 1.8V.
VDDADAC	193	A5	P	Analog power for Audio DAC 1.8V.
VSSADAC	195	D4,E5	G	Analog ground for Audio DAC 1.8V.
VSS	1,12, 29,35, 52,53, 70,75, 81,87, 104,105, 122,128, 145,156, 162,163, 202,203	F5~F12, G4~G13, H5~H12, J5~J12, K4~K13, L5~L12, M5~M12, N4,N7, N10,N13	G	Ground.

Pin Diagram

208 QFP Pin Diagram (Top -> Bottom View)

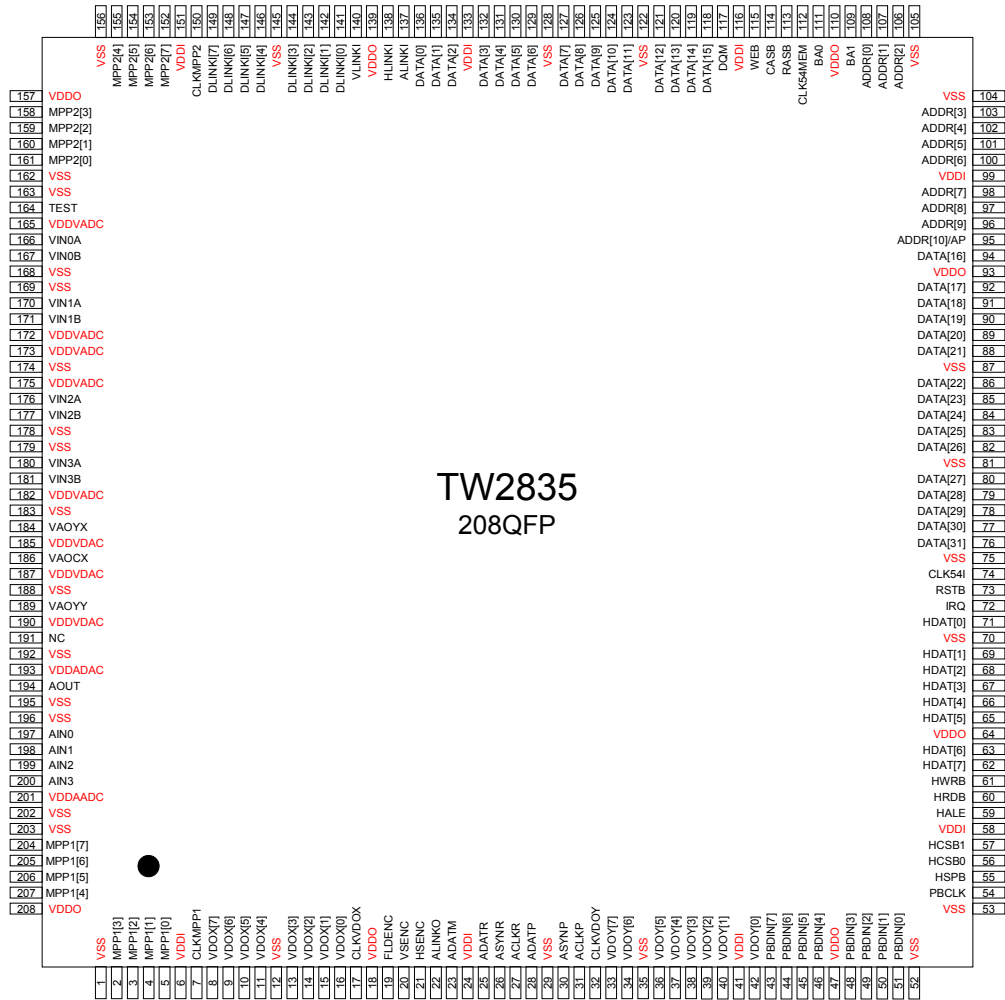

256 LPGA Pin Diagram (Top->Bottom View)

	A	B	C	D	E	F	G	H	J	K	L	M	N	P	R	T	
16	VDDO	MPP2 [7]	DLINKI [6]	VDDI	DLINKI [0]	DATA [0]	VDDI	DATA [6]	DATA [10]	VDDO	DQM	CLK 54MEM	VDDI	ADDR [1]	ADDR [2]	VDDO	16
15	MPP2 [5]	MPP2 [6]	DLINKI [7]	DLINKI [4]	DLINKI [1]	ALINKI	DATA [2]	DATA [5]	DATA [9]	DATA [12]	DATA [15]	RASB	BA1	ADDR [0]	ADDR [3]	ADDR [4]	15
14	MPP2 [4]	MPP2 [3]	CLK MPP2	DLINKI [5]	DLINKI [2]	HLINKI	DATA [1]	DATA [4]	DATA [8]	DATA [11]	DATA [14]	CASB	BA0	ADDR [5]	ADDR [6]	ADDR [7]	14
13	MPP2 [2]	MPP2 [1]	MPP2 [0]	VSS	DLINKI [3]	VLINKI	VSS	DATA [3]	DATA [7]	VSS	DATA [13]	WEB	VSS	ADDR [8]	ADDR [9]	VDDI	13
12	VDD VADC	VIN0A	VIN0B	TEST	VSS	VSS	VSS	VSS	VSS	VSS	VSS	VSS	ADDR [10]/AP	DATA [16]	DATA [17]	DATA [18]	12
11	VDD VADC	VIN1A	VIN1B	VSS	VSS	VSS	VSS	VSS	VSS	VSS	VSS	VSS	DATA [19]	DATA [20]	DATA [21]	DATA [22]	11
10	VDD VADC	VIN2A	VIN2B	VSS	VSS	VSS	VSS	VSS	VSS	VSS	VSS	VSS	VSS	DATA [23]	DATA [24]	VDDO	10
9	VDD VADC	VIN3A	VIN3B	VSS	VSS	VSS	VSS	VSS	VSS	VSS	VSS	VSS	DATA [25]	DATA [26]	DATA [27]	DATA [28]	9
8	VDD VADC	VDD VDAC	VAOYX	VAOCX	VSS	VSS	VSS	VSS	VSS	VSS	VSS	VSS	DATA [29]	DATA [30]	DATA [31]	CLK54I	8
7	VDD VDAC	VDD VDAC	VAOYY	NC	VSS	VSS	VSS	VSS	VSS	VSS	VSS	VSS	VSS	RSTB	IRQ	VDDO	7
6	VDD AADC	AIN0	AIN1	VSS	VSS	VSS	VSS	VSS	VSS	VSS	VSS	VSS	HDAT [0]	HDAT [1]	HDAT [2]	HDAT [3]	6
5	VDD ADAC	AIN2	AIN3	AOUT	VSS	VSS	VSS	VSS	VSS	VSS	VSS	VSS	HDAT [4]	HDAT [5]	HDAT [6]	HDAT [7]	5
4	MPP1 [7]	MPP1 [6]	MPP1 [5]	VSS	VDOX [0]	HS ENC	VSS	ADATP	VDOY [7]	VSS	VDOY [1]	PBDIN [5]	VSS	HWRB	HRDB	VDDI	4
3	MPP1 [4]	MPP1 [3]	MPP1 [2]	VDOX [4]	VDOX [1]	VS ENC	ADATM	ACLKR	CLK VDOY	VDOY [5]	VDOY [2]	PBDIN [6]	PBDIN [3]	HALE	HCSB1	HCSB0	3
2	MPP1 [1]	MPP1 [0]	VDOX [6]	VDOX [5]	VDOX [2]	FLD ENC	ALINKO	ASYNR	ACLKP	VDOY [6]	VDOY [3]	PBDIN [7]	PBDIN [4]	PBDIN [1]	PB CLK	HSPB	2
1	VDDO	CLK MPP1	VDOX [7]	VDDI	VDOX [3]	CLK VDOX	VDDI	ADATR	ASYNP	VDDO	VDOY [4]	VDOY [0]	VDDI	PBDIN [2]	PBDIN [0]	VDDO	1

Functional Description

Video Input

The TW2835 has 5 input interfaces that consist of 1 digital video input and 4 analog composite video inputs. Four analog video inputs are converted to digital video stream through 10 bits ADC and luminance/chrominance processor in built-in four video decoders. One digital input for playback application are decoded by internal ITU-R BT656 decoder and then fed to video control part and channel ID decoder. Each built-in video decoder has its own motion detector and dual scaler. Four additional scalars are also embedded for playback display application. The structure of video input is shown in the following Fig 1.

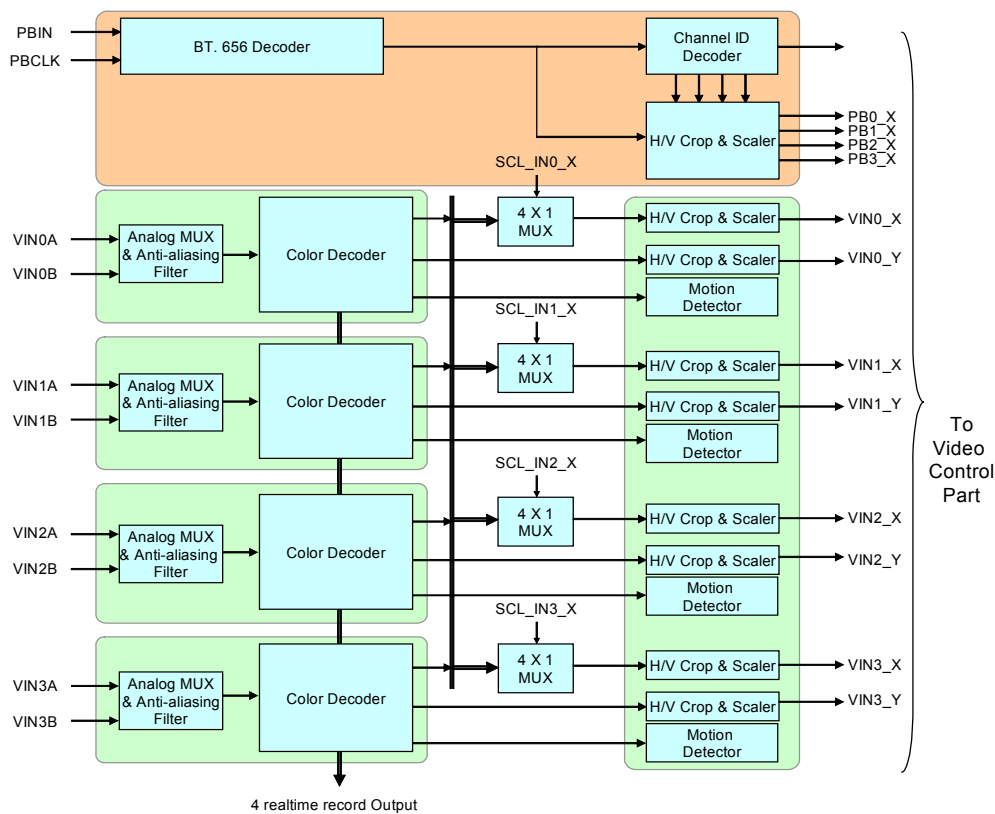

Fig 1 The structure of video input

For the special 4ch real-time record application, the TW2835 supports 4 realtime video decoder outputs through the multi-purpose output pins (MPP1[7:0] and MPP2[7:0]).

Analog Video Input

The TW2835 supports all NTSC/PAL video standards for analog input and contains automatic standard detection circuit. Automatic standard detection can be overridden by writing the value into the IFMTMAN and IFORMAT (0x01, 0x11, 0x21, and 0x31) registers. Even if video loss is detected, the TW2835 can be forced to free-running in a particular video standard mode by IFORMAT register. The Table 1 shows the video input standards supported by TW2835.

Table 1 Video input standards

IFORMAT	PEDEST	Format	Line/Fv (Hz)	Fh (KHz)	Fsc (MHz)
0	0	PAL-BDGHI	625/50	15.625	4.43361875
	1	PAL-N*			
1	1	PAL-M*	525/59.94	15.734	3.57561149
2	0	PAL-NC	625/50	15.625	3.58205625
3	0	PAL-60	525/59.94	15.734	4.43361875
4	0	NTSC-J	525/59.94	15.734	3.579545
	1	NTSC-M*			
5	1	NTSC-4.43*	525/59.94	15.734	4.43361875
6	0	NTSC-N	625/50	15.625	3.579545

Notes: * 7.5 IRE Setup

Anti-aliasing Filter

The TW2835 contains an anti-aliasing filter to prevent out-of-band frequency in analog video input signal. So there is no need of external components in analog input pin except ac coupling capacitor and termination resistor. The following Fig 2 shows the frequency response of the anti-aliasing filter.

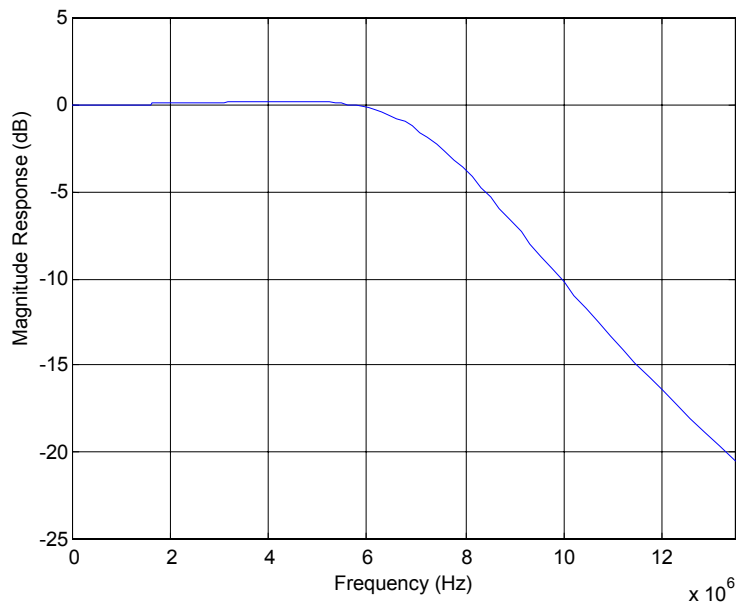

Fig 2. The frequency response of anti-aliasing filter

Analog-to-Digital Converter

The TW2835 contains four 10-bit ADC (Analog to Digital Converters) to digitize the analog video inputs. Each ADC has two analog switches that are controlled by the ANA_SW (0x0D, 0x1D, 0x2D, and 0x3D) register. The ADC can also be put into power-down mode by the ADC_PWDN (0x4C) register.

Sync Processing

The sync processor of the TW2835 detects horizontal and vertical synchronization signals in the composite video signal. The TW2835 utilizes proprietary technology for locking to weak, noisy, or unstable signals such as those from on air signal or fast forward/backward play of VCR system.

A digital gain and clamp control circuit restores the ac coupled video signal to a fixed dc level. The clamping circuit provides line-by-line restoration of the video pedestal level to a fixed dc reference voltage. In no AGC mode, the gain control circuit adjusts only the video sync gain to achieve desired sync amplitude so that the active video is bypassed regardless of the gain control. But when AGC mode is enabled, both active video and sync are adjusted by the gain control.

The horizontal synchronization processor contains a sync separator, a PLL and the related decision logic. The horizontal sync separator detects the horizontal sync by examining low-pass filtered video input whose level is lower than a threshold. Additional logic is also used to avoid false detection on glitches. The horizontal PLL locks onto the extracted horizontal sync in all conditions to provide jitter free image output. In case of missing horizontal sync, the PLL is on free running status that matches the standard raster frequency.

The vertical sync separator detects the vertical synchronization pattern in the input video signals. The field status is determined at vertical synchronization time. When the location of the detected vertical sync is inline with a horizontal sync, it indicates a frame start or the odd field start. Otherwise, it indicates an even field.

Color Decoding

The digitized composite video data at 2X pixel clock rate first passes through decimation filter. The decimation filter is required to achieve optimum performance and prevent high frequency components from being aliased back into the video image. The following Fig 3 shows the frequency characteristic of the decimation filter.

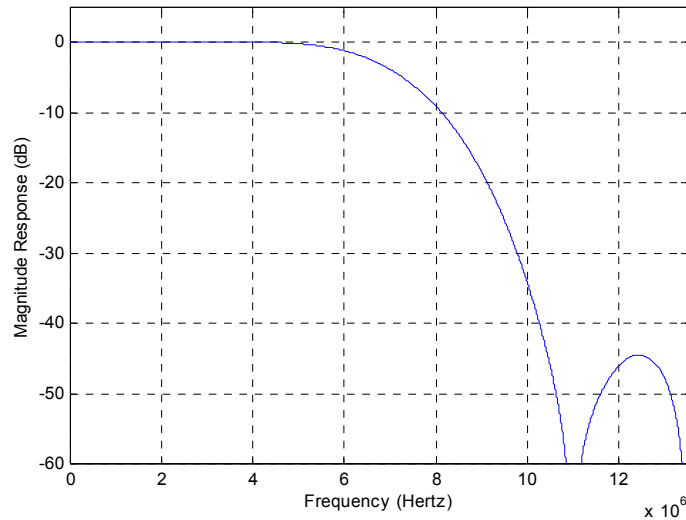

Fig 3 The frequency characteristic of the decimation Filter

The adaptive comb filter is used for high performance luminance/chrominance separation from NTSC/PAL composite video signals. The comb filter improves the luminance resolution and reduces noise such as cross-luminance and cross-color. The adaptive algorithm eliminates most of errors without introducing new artifacts or noise. To accommodate some viewing preferences, additional chrominance trap filters are also available in the luminance path.

Fig 4 and Fig 5 show the frequency response of notch filter for each system NTSC and PAL.

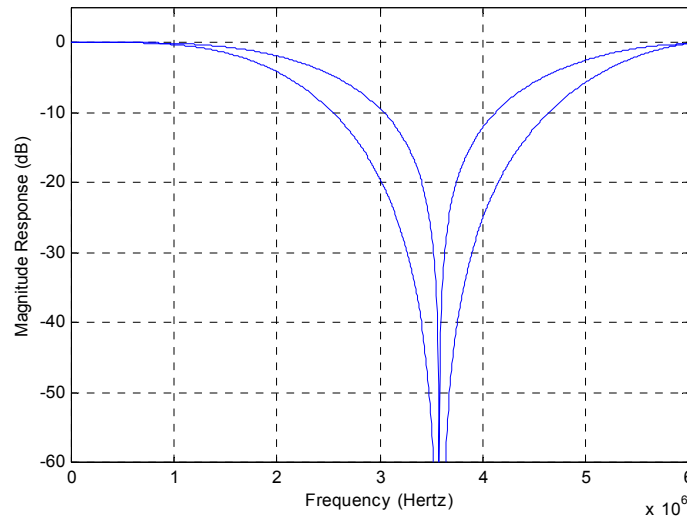

Fig 4 The frequency response of luminance notch filter for NTSC

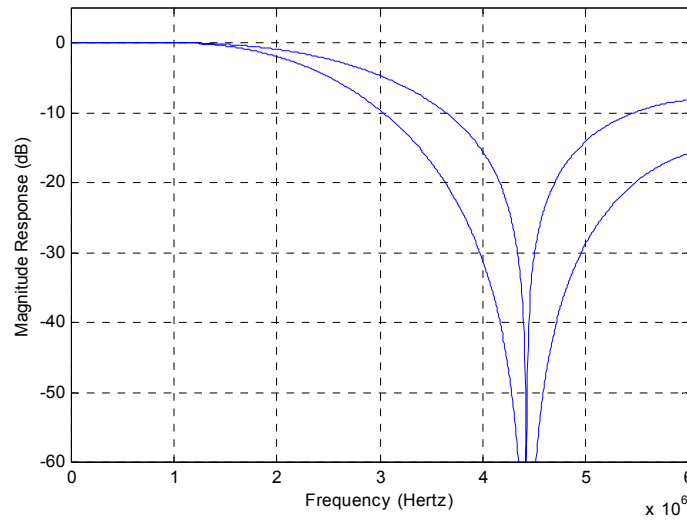

Fig 5 The frequency response of luminance notch filter for PAL

Luminance Processing

The luminance signal separated by adaptive comb or trap filter is then fed to a peaking circuit. The peaking filter enhances the high frequency components of the luminance signal via the Y_PEAK (0x0B, 0x1B, 0x2B, and 0x3B) register. The following Fig 6 shows the characteristics of the peaking filter for four different gain modes.

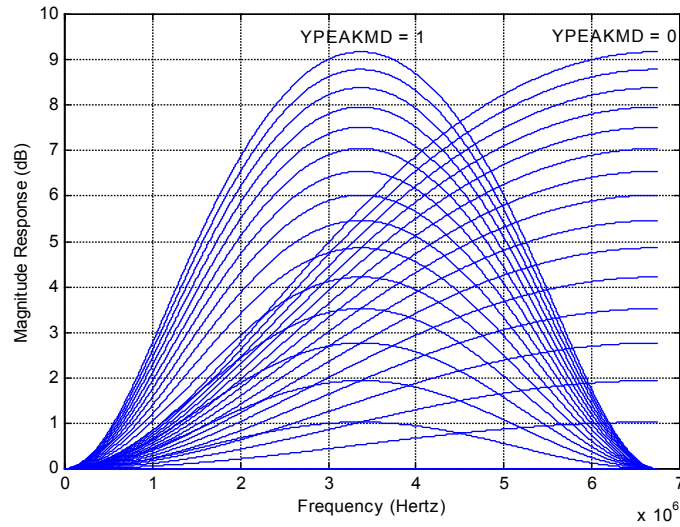

Fig 6 The frequency characteristic of luminance peaking filter

The picture contrast and brightness adjustment is provided through the CONT (0x09, 0x19, 0x29, and 0x39) and BRT (0x0A, 0x1A, 0x2A, and 0x3A) registers. The contrast adjustment range is from approximately 0 to 200 percent and the brightness adjustment is in the range of ± 25 IRE.

Chrominance Processing

The chrominance demodulation is done by first quadrature mixing for NTSC and PAL. The mixing frequency is equal to the sub-carrier frequency of NTSC and PAL. After the mixing, a LPF is used to remove 2X carrier signal and yield chrominance components. The characteristic of LPF can be selected for optimized transient color performance. The Fig 7 is showing the frequency response of chrominance LPF.

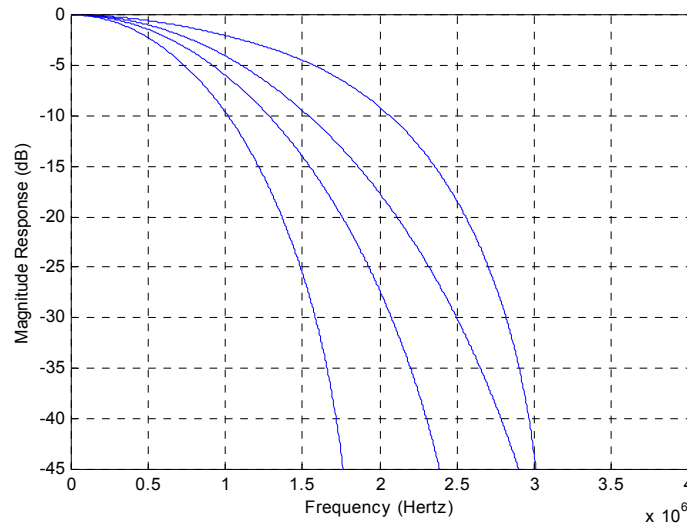

Fig 7 The frequency response of chrominance LPF

In case of a mistuned IF source, IF compensation filter makes up for any attenuation at higher frequencies or asymmetry around the color sub-carrier. The gain for the upper chrominance side band is controlled by the IFCOMP (0x46) register. The Fig 8 shows the frequency response of IF-compensation filter.

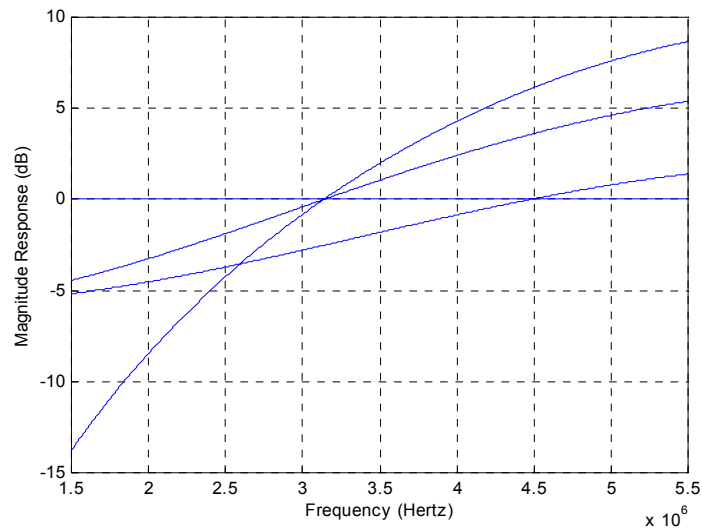

Fig 8 The frequency characteristics of IF-compensation filter

The ACC (Automatic Color gain Control) compensates for reduced chrominance amplitudes caused by high frequency suppression in video signal. The range of ACC is from -6dB to 30dB approximately. For black & white video or very weak & noisy signals, the internal color killer circuit will turn off the color. The color killing function can also be always enabled or disabled by programming CKIL (0x0C, 0x1C, 0x2C, and 0x3C) register.

The color saturation can be adjusted by changing SAT (0x08, 0x18, 0x28, and 0x38) register. The Cb and Cr gain can be also adjusted independently by programming UGAIN (0x48) and VGAIN (0x49) registers. Likewise, the Cb and Cr offset can be programmed through the U_OFF (0x4A) and V_OFF (0x4B) registers. Hue control is achieved with phase shift of the digitally controlled oscillator. The phase shift can be programmed through the HUE (0x07, 0x17, 0x27, and 0x37) register.

Realtime Record Mode

The TW2835 supports four channel real-time record outputs with full D1 format through the DLINKI and MPP1/2 pins. Four channel real-time record outputs are independent of display and record path mode. The TW2835 also supports H/V/F signals for each channel through the DLINKI and MPP1/2 pins. The output modes of DLINKI and MPP1/2 pins are controlled via the MPP_MD (1xB0) and MPP_SET (1xB1, 1xB3, and 1xB5) registers.

Digital Video Input

The TW2835 supports digital video input with 8bit ITU-R BT.656 standard for playback. This digital input is decoded in built-in ITU-R BT 656 decoder and fed to the scaler block in order to display the scaled video data. The TW2835 supports error correction mode for decoding ITU-R BT.656. The decoded video data are also transferred to channel ID decoder part for auto cropping and strobe function.

Digital Video Input Format

The timing of digital video input is illustrated in Fig 9.

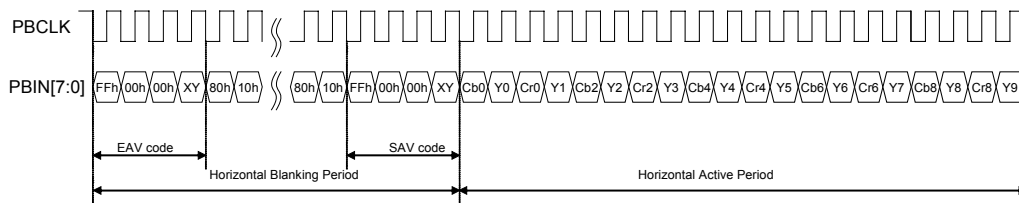

Fig 9 Timing diagram of ITU-R BT.656 format for digital video input

The SAV and EAV sequences are shown in Table 2.

Table 2 ITU-R BT.656 SAV and EAV code sequence

Condition			656 FVH Value			SAV/EAV Code Sequence												
Field	Vertical	Horizontal	F	V	H	First	Second	Third	Fourth									
EVEN	Blank	EAV	1	1	1	0xFF	0x00	0x00	0xF1									
		SAV			0				0xEC									
EVEN	Active	EAV	1	0	1				0xFF	0x00	0x00	0xDA						
		SAV			0							0xC7						
ODD	Blank	EAV	0	1	1							0xFF	0x00	0x00	0xB6			
		SAV			0										0xAB			
ODD	Active	EAV	0	0	1										0xFF	0x00	0x00	0x9D
		SAV			0													0x80

Channel ID Decoder

The TW2835 provides channel ID decoding function for playback input. The TW2835 supports three kinds of channel ID such as User channel ID, Detection channel ID, and auto channel ID. The User channel ID is used for customized information like system information and date. The Detection channel ID is used for detected information of current live input such as motion, video loss, blind and night detection information. The auto channel ID is employed for automatic identification of picture configuration which includes the channel number, analog switch, event, region enable and field/frame mode information. The TW2835 also supports both analog and digital type channel ID during VBI period. The digital channel ID has priority over analog channel ID. The analog type channel ID decoding is enabled via the VBI_ENA (1x86) register and the digital type channel ID decoding is operated via VBI_CODE_EN (1x86) register. Additionally to detect properly the analog channel ID against noise such as VCR source, the channel ID LPF can be enabled via the VBI_FLT_EN (1x86) register. The decoded channel ID information is used for auto cropping / strobe function and can also be read through the host interface. The detailed auto cropping / strobe function for playback input will be described at "Cropping Function" section (page 34) and "Playback Path Control" section (page 57).

For channel ID detection mode, the TW2835 supports both automatic channel ID detection mode and manual channel ID detection mode. For an automatic channel ID detection mode, the playback input should include a run-in clock. But for a manual channel ID detection mode, the playback input can include a run-in clock or not via VBI_RIC_ON (1x88) register. In a manual detection mode, the TW2835 has several related register such as the VBI_PIXEL_HOS (1x87) to define horizontal start offset, the VBI_FLD_OS (1x88) to define line offset between odd and even field, the VBI_PIXEL_HW to define pulse width for 1 bit data, the VBI_LINE_SIZE (1x89) to define channel ID line size and the VBI_LINE_OS (1x89) to define line offset for channel ID. The VBI_MID_VAL (1x8A) register is used to define the threshold level between high and low. Even in automatic channel ID detection mode, the line size and bit width can be discriminated by reading the VBI_LINE_SIZE and VBI_PIXEL_HW (1xCB) register. The Fig 10 shows the relationship between channel ID and register setting.

This channel ID information can be read through the CHID_TYPE or CHID_VALID (1x8B), AUTO_CHID 0/1/2/3 (1x8C~ 1x8F), DET_CHID 0/1/2/3/4/5/6/7 (1x98~1x9F), and USER_CHID 0/1/2/3/4/5/6/7 (1x90~1x97) registers. The CHID_TYPE register discriminates between the Auto channel ID (CHID_TYPE = "1") and User channel ID (CHID_TYPE = "0"). The CHID_VALID register indicates whether the detected channel ID type is valid or not. The AUTO_CHID, DET_CHID and USER_CHID registers are used to check the decoded channel ID data when the VBI_RD_CTL (1x88) register value is "1".

Basically the channel ID is located in VBI period and auto strobe and cropping is executed after channel ID decoding. But for some case, the channel ID can be placed in vertical active period instead of VBI period. For this mode, the TW2835 also supports the channel ID decoding

function within vertical active period via the VAV_CHK (1x89) register and manual cropping function via the MAN_PBCROP (0xC0) register with proper VDELAY value.

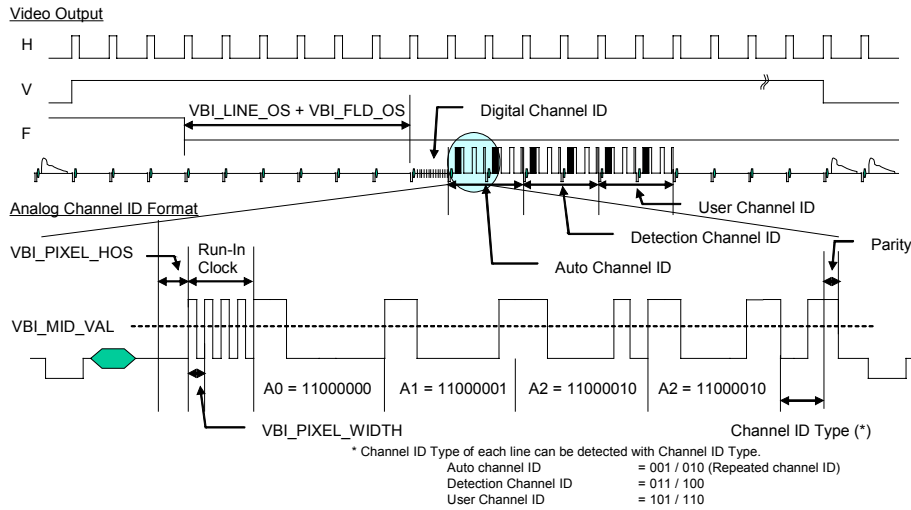

Fig 10 The related register for manual channel ID detection

Cropping and Scaling Function

The TW2835 provides two methods to reduce the amount of video pixel data, scaling and cropping. The scaling function provides video image at lower resolution while the cropping function supplies only a portion of the video image. The TW2835 also supports an auto cropping function for playback input with channel ID decoding. The TW2835 has a free scaler for a variable image size in display path, but has a limitation of image size in record path such as Full / QUAD / CIF format.

Cropping Function for Live

The cropping function allows only subsection of a video image to be output. The active video region is determined by the HDELAY, HACTIVE, VDELAY and VACTIVE (0x02 ~ 0x06, 0x12 ~ 0x16, 0x22 ~ 0x26, 0x32 ~ 0x36) register. The first active line is defined by the VDELAY register and the first active pixel is defined by the HDELAY register. The VACTIVE register can be programmed to define the number of active lines in a video field, and the HACTIVE register can be programmed to define the number of active pixels in a video line. This function is used to implement for panning and tilt.

The horizontal delay register HDELAY determines the number of pixel delays between the horizontal reference and the leading edge of the active region. The horizontal active register HACTIVE determines the number of active pixels to be processed. Note that these values are referenced to the pixel number before scaling. Therefore, even if the scaling ratio is changed, the active video region used for scaling remains unchanged as set by the HDEALY and HACTIVE register. In order for the cropping to work properly, the following equation should be satisfied.

$$\text{HDELAY} + \text{HACTIVE} < \text{Total number of pixels per line}$$

Where the total number of pixels per line is 858 for NTSC and 864 for PAL

To process full size region, the HDELAY should be set to 32 and HACTIVE set to 720 for both NTSC and PAL system.

The vertical delay register (VDELAY) determines the number of line delays from the vertical reference to the start of the active video lines. The vertical active register (VACTIVE) determines the number of lines to be processed. These values are referenced to the incoming scan lines before the vertical scaling. In order for the vertical cropping to work properly, the following equation should be satisfied.

$$\text{VDELAY} + \text{VACTIVE} < \text{Total number of lines per field}$$

Where the total number of lines per field is 262 for NTSC and 312 for PAL

To process full size region, the VDELAY should be set to 6 and VACTIVE set to 240 for NTSC and the VDELAY should be also set to 5 and VACTIVE set to 288 for PAL.

Scaling Function for Live

The TW2835 includes a high quality free horizontal and vertical down scaler for display path. But the TW2835 cannot use a free scaler function in record path because channel size definition for record path has a limitation such as Full / QUAD / CIF (Please refer to “Record Path Control” section, page 64).

The video images can be downscaled in both horizontal and vertical direction to an arbitrary size. The luminance horizontal scaler includes an anti-aliasing filter to reduce image artifacts in the resized image via the HSFLT (0x80/90/A0/B0, 0x85/95/A5/B5 and 0x8A/9A/AA/BA) register and a 32 poly-phase filter to accurately interpolate the value of a pixel. This results in more aesthetically pleasing video as well as higher compression ratio in bandwidth-limited application.

The following Fig 11 shows the frequency response of anti-aliasing filter for horizontal scaling.

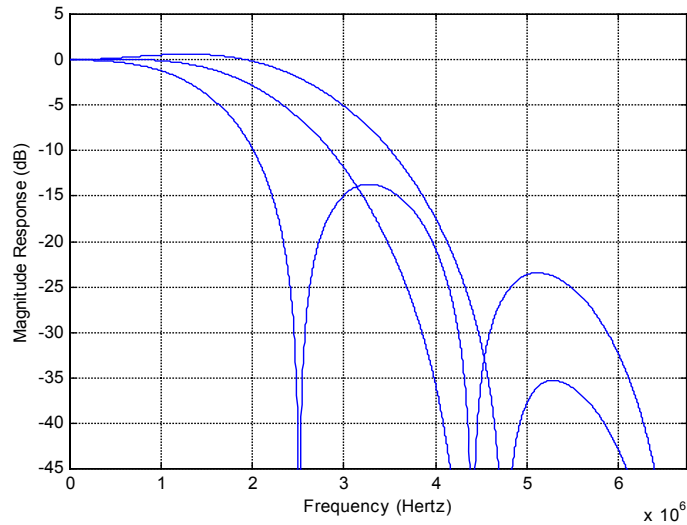

Fig 11 The frequency response of anti-aliasing filter for horizontal scaling

Similarly, the vertical scaler also contains an anti-aliasing filter controlled via the VSFLT (0x80/90/A0/B0, 0x85/95/A5/B5 and 0x8A/9A/AA/BA) register and 16 poly-phase filters for down scaling. The filter characteristics are shown in the Fig 12.

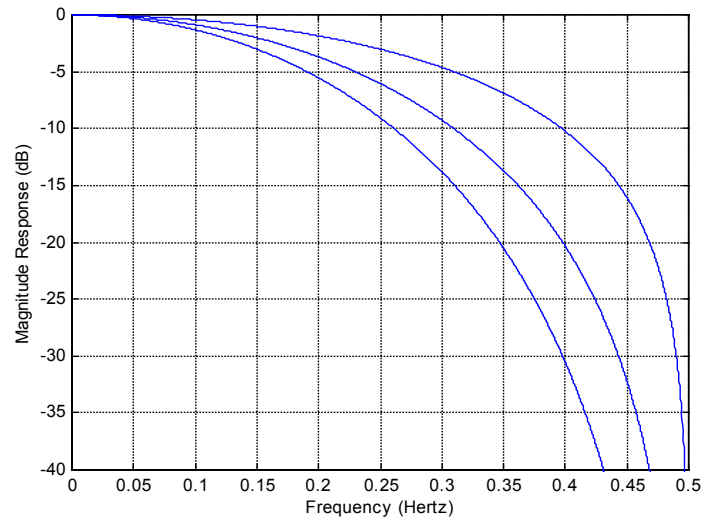

Fig 12 The characteristics of anti-aliasing filter for vertical scaling

Down scaling is achieved by programming the scaling register HSCALE and VSCALE (0x81 ~ 0x84, 0x91 ~ 0x94, 0xA1 ~ 0xA4, 0xB1 ~ 0xB4) register. When no scaled video image, the TW2835 will output the number of pixels as specified by the HACTIVE and VACTIVE (0x02 ~ 0x06, 0x12 ~ 0x16, 0x22 ~ 0x26, 0x32 ~ 0x36) register. If the number of output pixels required is smaller than the number specified by the HACTIVE/VACTIVE register, the 16bit HSCALE/VSCALE register is used to reduce the output pixels to the desired number.

The following equation is used to determine the horizontal scaling ratio to be written into the 16bit HSCALE register.

$$HSCALE = [N_{\text{pixel_desired}} / HACTIVE] * (2^{16} - 1)$$

Where $N_{\text{pixel_desired}}$ is the desired number of active pixels per line

For example, to scale picture from full size (HACTIVE = 720) to CIF (360 pixels), the HSCALE value can be found as:

$$HSCALE = [360/720] * (2^{16} - 1) = 0x7FFF$$

The following equation is used to determine the vertical scaling ratio to be written into the 16bit VSCALE register.

$$VSCALE = [N_{\text{line_desired}} / VACTIVE] * (2^{16} - 1)$$

Where $N_{\text{line_desired}}$ is the desired number of active lines per field

For example, to scale picture from full size (VACTIVE = 240 lines for NTSC and 288 lines for PAL) to CIF (120 lines for NTSC and 144 lines for PAL), the VSCALE value can be found as:

$$VSCALE = [120 / 240] * (2^{16} - 1) = 0x7FFF \text{ for NTSC}$$

$$VSCALE = [144 / 288] * (2^{16} - 1) = 0x7FFF \text{ for PAL}$$

The scaling ratios of popular case are listed in Table 3.

Table 3 HSCALE and VSCALE value for popular video formats

Scaling Ratio	Format	Output Resolution	HSCALE	VSCALE
1	NTSC	720x480	0xFFFF	0xFFFF
	PAL	720x576	0xFFFF	0xFFFF
1/2 (CIF)	NTSC	360x240	0x7FFF	0x7FFF
	PAL	360x288	0x7FFF	0x7FFF
1/4 (QCIF)	NTSC	180x120	0x3FFF	0x3FFF
	PAL	180x144	0x3FFF	0x3FFF

The effect of scaling and cropping is shown in Fig 13.

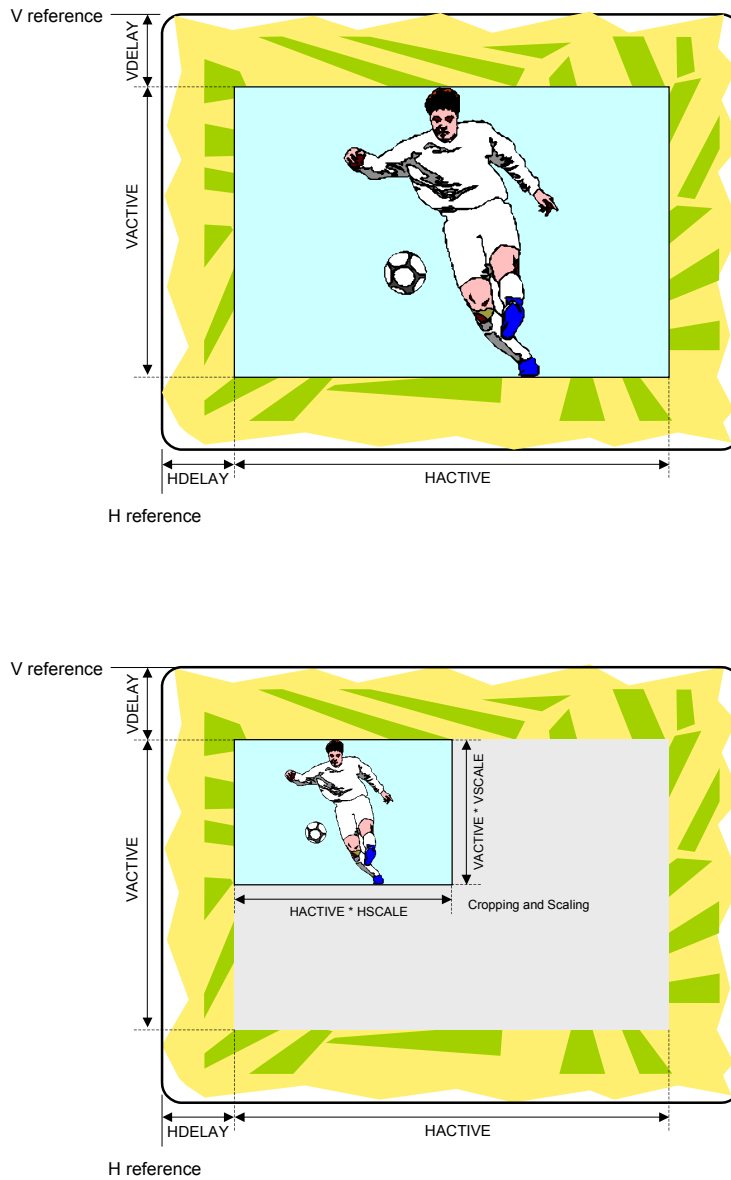

Fig 13 The effect of cropping and scaling

Cropping and Scaling Function for Playback

The TW2835 supports an auto cropping function with channel ID decoding for playback input. Each channel with the multiplexed playback input can be mapped into the desired position with the auto cropping function.

If the PB_AUTO_EN (1x16) = "0", the TW2835 is set to a manual cropping mode so that user can control cropping with VDELAY_PB and HDELAY_PB (0x8B~0x8F, 0x9B~9F, 0xAB~AF and 0xBB~BF) register. If the PB_AUTO_EN = "1", the TW2835 is set into an auto cropping mode. In this mode, the desired channel can be chosen by PB_CH_NUM register (1x16, 1x1E, 1x26, 1x2E) and it will be cropped automatically to horizontal and vertical direction in playback input. The TW2835 has several related registers for this mode such as PB_CROP_MD, PB_ACT_MD and MAN_PBCROP (0xC0). The PB_CROP_MD defines the record mode of the playback input such as normal record mode or DVR record mode (Please refer to "Record Path Control" section, page 64). The PB_ACT_MD defines an active pixel size of horizontal direction such as 720 / 704 / 640 pixels. The MAN_PBCROP controls the horizontal and vertical starting offset in the auto cropping mode with HDELAY_PB and VDELAY_PB registers. It is useful in case that the encoded channel ID is located at vertical active area in ITU-R BT.656 data stream.

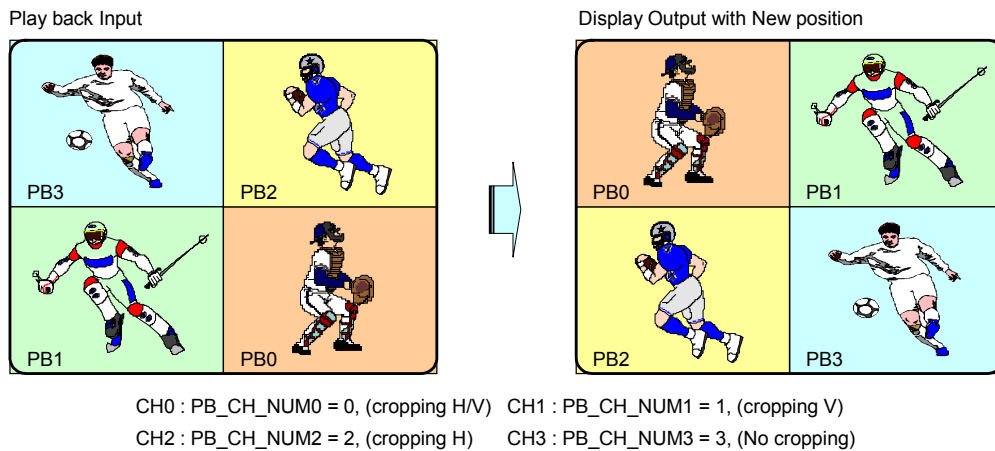

Fig 14 The effect of auto cropping function

The TW2835 includes four additional free down scaler for playback path so that the video image from playback input can be downscaled to an arbitrary size in both horizontal and vertical direction. Therefore, using this cropping and scaling function, the TW2835 supports free size and positioning function for both live and playback input in display path. The following Fig 15 shows the effect of scaling and cropping operation in playback.

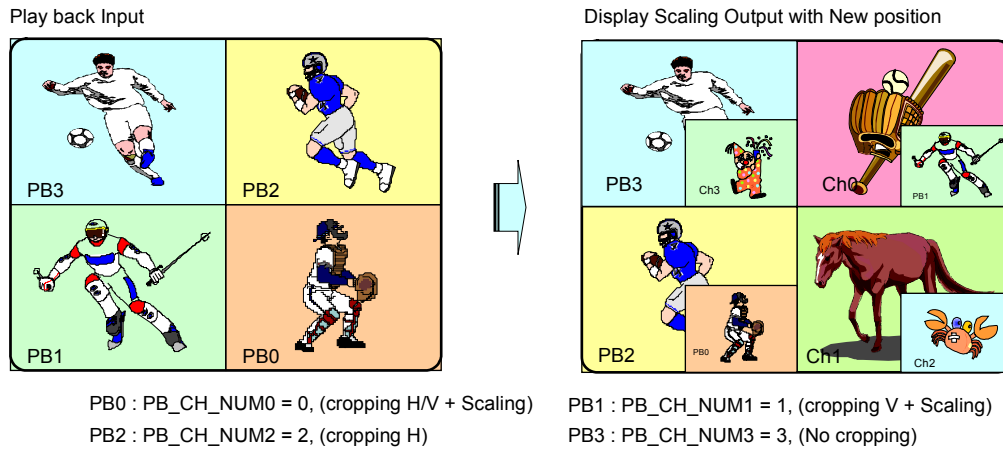

Fig 15 The effect of scaling function in playback

Motion Detection

The TW2835 supports motion detector individually for 4 analog video inputs. The built-in motion detection algorithm uses the difference of luminance level between current and reference field. The TW2835 also supports blind and night input detection for 4 analog video inputs.

To detect motion properly according to situation, the TW2835 provides several sensitivity and velocity control parameters for each motion detector. The TW2835 supports manual strobe function to update motion detection so that it is more appropriate for user-defined motion sensitivity control.

When motion, blind and night input are detected in any video inputs, the TW2835 provides the interrupt request to host via the IRQ pin. The host processor can take the information of motion, blind or night detection by accessing the IRQENA_MD (1x79), IRQENA_BD (1x7A) and the IRQENA_ND (1x7B) register. This status information is updated in the vertical blank period of each input.

The TW2835 also provides the motion, blind and night detection result through the DLINKI and MPP0/1 pin with the control of MPP_MD (1xB0) and MPP_SET (1xB1, 1xB3 and 1xB5) register. The TW2835 supports an overlay function to display the motion detection result in the picture with 2D arrayed box.

Mask and Detection Region Selection

The motion detection algorithm utilizes the full screen video data and detects individual motion of 16x12 cells. This full screen for motion detection consists of 704 pixels and 240 lines for NTSC and 288 lines for PAL. Starting pixel in horizontal direction can be shifted from 0 to 15 pixels using the MD_ALIGN (2x82, 2xA2, 2xC2, and 2xE2) register.

Each cell can be masked via the MD_MASK (2x86 ~ 2x9D, 2xA6 ~ 2xBD, 2xC6 ~ 2xDD, 2xE6 ~ 2xFD) register as illustrated in Fig 16. If the mask bit in specific cell is programmed to high, the related cell is ignored for motion detection.

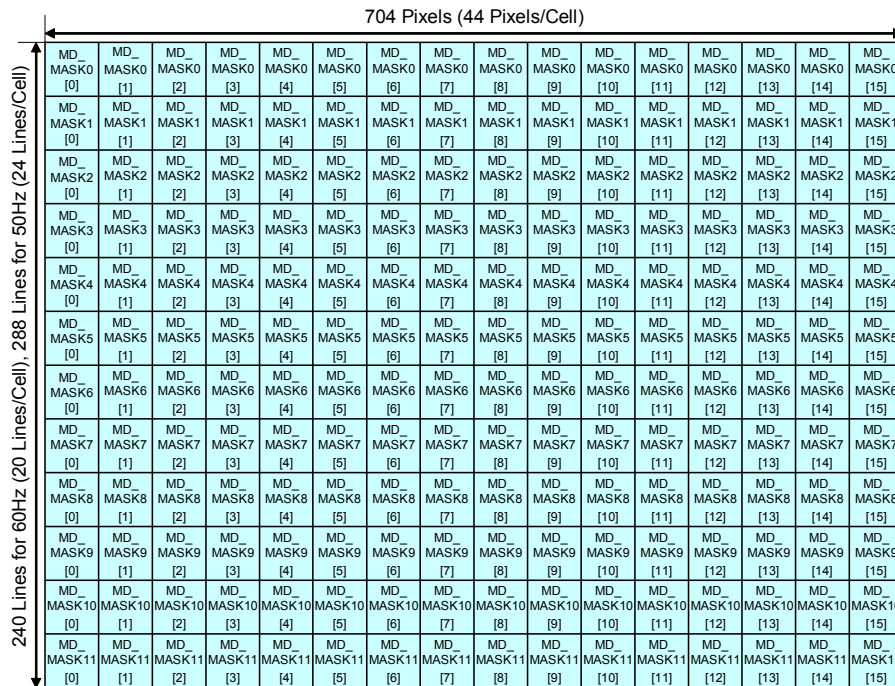

Fig 16 Motion mask and detection cell

The MD_MASK register has different function for reading and writing mode. For writing mode, setting “1” to MD_MASK register inhibits the specific cell from detecting motion. For reading mode, the MD_MASK register has three kinds of information depending on the MASK_MODE (2x82, 2xA2, 2xC2, and 2xE2) register. For MASK_MODE = “0”, the state of MD_MASK register means the result of VIN_A motion detection that “1” indicates detecting motion and “0” denotes no motion detection in the cell. For MASK_MODE = “1”, the state of MD_MASK register means the result of VIN_B motion detection. For MASK_MODE = “2 or 3”, the state of MD_MASK register means masking information of cell.

Sensitivity Control

The motion detector has 4 sensitivity parameters to control threshold of motion detection such as the level sensitivity via the MD_LVSENS (2x83, 2xA3, 2xC3, and 2xE3) register, the spatial sensitivity via the MD_SPSSENS (2x85, 2xA5, 2xC5, 2xE5) and MD_CELSENS (2x83, 2xA3, 2xC3, and 2xE3) register, and the temporal sensitivity parameter via the MD_TMPSENS (2x85, 2xA5, 2xC5, and 2xE5) register.

Level Sensitivity

In built-in motion detection algorithm, the motion is detected when luminance level difference between current and reference field is greater than MD_LVSENS value. Motion detector is more sensitive for the smaller MD_LVSENS value and less sensitive for the larger. When the MD_LVSENS is too small, the motion detector may be weak in noise.

Spatial Sensitivity

The TW2835 uses 192 (16x12) detection cells in full screen for motion detection. Each detection cell is composed of 44 pixels and 20 lines for NTSC and 24 lines for PAL. Motion detection from only luminance level difference between two fields is very weak in spatial random noise. To remove the fake motion detection from the random noise, the TW2835 supports a spatial filter via the MD_SPSSENS register which defines the number of detected cell to decide motion detection in full size image. The large MD_SPSSENS value increases the immunity of spatial random noise.

Each detection cell has 4 sub-cells also. Actually motion detection of each cell comes from comparison of sub-cells in it. The MD_CELSENS defines the number of detected sub-cell to decide motion detection in cell. That is, the large MD_CELSENS value increases the immunity of spatial random noise in detection cell.

Temporal Sensitivity

Similarly, temporal filter is used to remove the fake motion detection from the temporal random noise. The MD_TMPSENS regulates the number of taps in the temporal filter to control the temporal sensitivity so that the large MD_TMPSENS value increases the immunity of temporal random noise.

Velocity Control

The motion has various velocities. That is, in a fast motion an object appears and disappears rapidly between the adjacent fields while in a slow motion it is to the contrary. As the built-in motion detection algorithm uses the only luminance level difference between two adjacent fields, a slow motion is inferior in detection rate to a fast motion. To compensate this weakness, MD_SPEED (2x84, 2xA4, 2xC4, and 2xE4) parameter is used which is controllable up to 64 fields. MD_SPEED parameter adjusts the field interval in which the luminance level is compared. Thus, for detection of a fast motion a small value is needed and for a slow motion a large value is required. The parameter MD_SPEED value should be greater than MD_TMPSENS value.

Additionally, the TW2835 has 2 more parameters to control the selection of reference field. The MD_FLD (2x82, 2xA2, 2xC2, and 2xE2) register is a field selection parameter such as odd, even, any field or frame.

The MD_REFFLD (2x80, 2xA0, 2xC0, and 2xE0) register is provided to control the updating period of reference field. For MD_REFFLD = "0", the interval from current field to reference field is always same as the MD_SPEED. It means that the reference field is always updated every field. The Fig 17 shows the relationship between current and reference field for motion detection when the MD_REFFLD is "0".

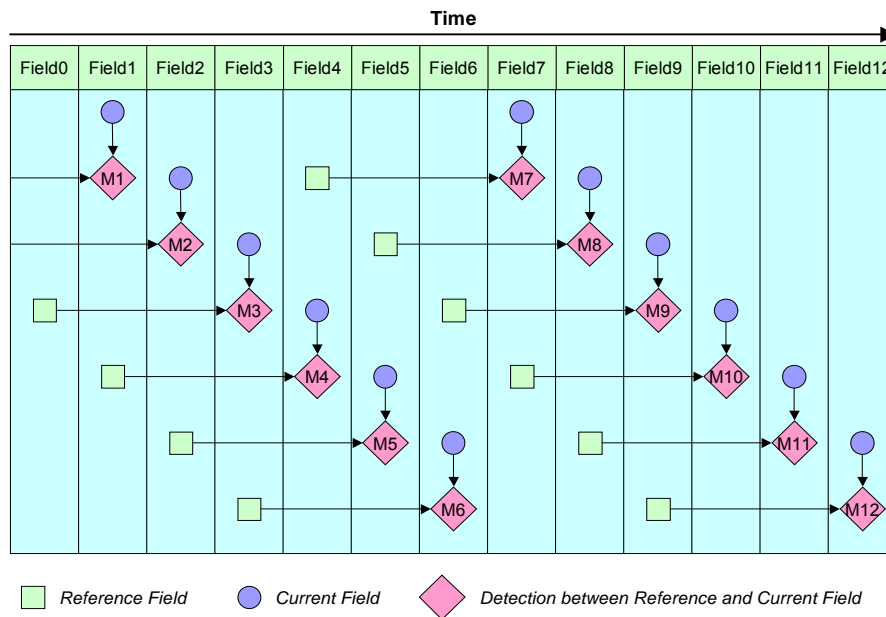

Fig 17 The relationship between current and reference field when MD_REFFLD = "0"

The TW2835 can update the reference field only at the period of MD_SPEED when the MD_REFFLD is high. For this case, the TW2835 can detect a motion with sense of a various velocity. The Fig 18 shows the relationship between current and reference field for motion detection when the MD_REFFLD = "1".

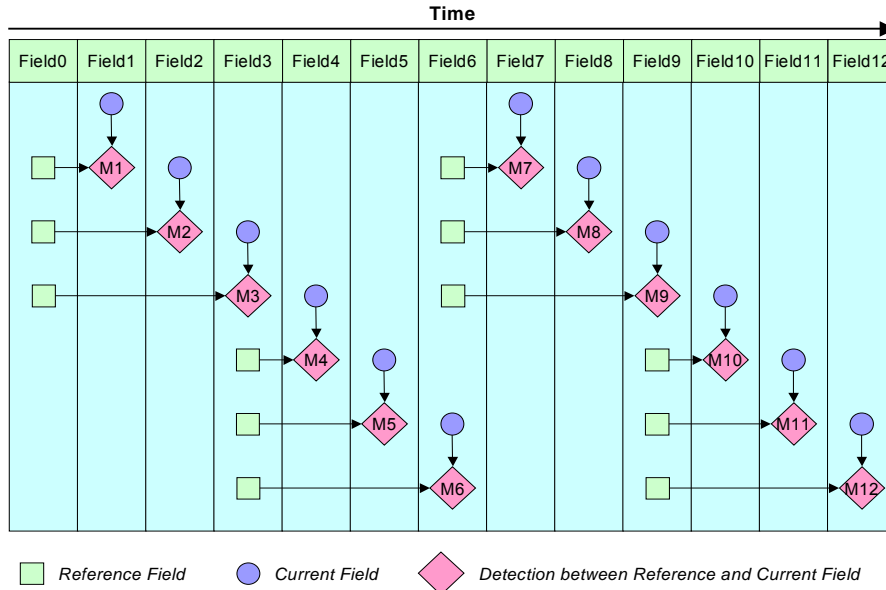

Fig 18 The relationship between current and reference field when MD_REFFLD = "1"

The TW2835 also supports the manual detection timing control of the reference field/frame via the MD_STRB_EN and MD_STRB (2x84, 2xA4, 2xC4, and 2xE4) register. For MD_STRB_EN = "0", the reference field/frame is automatically updated and reserved on every reference field/frame. For MD_STRB_EN = "1", the reference field/frame is updated and reserved only when MD_STRB = "1". In this mode, the interval between current and reference field/frame depends on user's strobe timing. This mode is very useful for a specific purpose like non-periodical velocity control and very slow motion detection.

The TW2835 also provides dual detection mode for non-realtime application such as pseudo-8ch application via MD_DUAL_EN (2x83, 2xA3, 2xC3, and 2xE3) register. For MD_DUAL_EN = 1, the TW2835 can detect dual motion independently for VIN_A and B Input which is defined by the ANA_SW (0x0D, 0x1D, 0x2D, and 0x3D) register. In this case, the MD_SPEED is limited to 31. These motion information can be read via the IRQENA_MD (1x79) register by the host interface.

Blind Detection

The TW2835 supports blind detection individually for 4 analog video inputs and makes an interrupt of blind detection to host. If video level in wide area of field is almost equal to average video level of field due to camera shaded by something, this input is defined as blind input.

The TW2835 has two sensitivity parameters to detect blind input such as the level sensitivity via the BD_LVSENS (2x80, 2xA0, 2xC0, and 2xE0) register and spatial sensitivity via the BD_CELSENS (2x80, 2xA0, 2xC0, and 2xE0) register.

The TW2835 uses total 768 (32x24) cells in full screen for blind detection. The BD_LVSENS parameter controls the threshold of level between cell and field average. The BD_CELSENS parameter defines the number of cells to detect blind. For BD_CELSENS = "0", the number of cell whose level is same as average of field should be over than 60% to detect blind, 70% for BD_CELSENS = "1", 80% for BD_CELSENS = "2", and 90% for BD_CELSENS = "3". That is, the large value of BD_LVSENS and BD_CELSENS makes blind detector less sensitive.

The TW2835 also supports dual detection mode for non-realtime application such as pseudo-8ch application via the MD_DUAL_EN (2x83, 2xA3, 2xC3, and 2xE3) register. The host can read blind detection information for both VIN_A and VIN_B input via the IRQENA_BD (1x7A) register.

Night Detection

The TW2835 supports night detection individually for 4 analog video inputs and makes an interrupt of night detection to host. If an average of field video level is very low, this input is defined as night input. Likewise, the opposite is defined as day input.

The TW2835 has two sensitivity parameters to detect night input such as the level sensitivity via the ND_LVSENS (2x81, 2xA1, 2xC1, and 2xE1) register and the temporal sensitivity via the ND_TMPSENS (2x81, 2xA1, 2xC1, and 2xE1) register. The ND_LVSENS parameter controls threshold level of day and night. The ND_TMPSENS parameter regulates the number of taps in the temporal low pass filter to control the temporal sensitivity. The large value of ND_LVSENS and ND_TMPSENS makes night detector less sensitive.

The TW2835 also supports dual detection mode for non-realtime application such as pseudo-8ch application via the MD_DUAL_EN (2x83, 2xA3, 2xC3, and 2xE3) register. The host can read night detection information for both VIN_A and VIN_B input via the IRQENA_ND (1x7B) register.

Video Control

The TW2835 has dual video controllers for display and record path. The TW2835 requires only external 64M SDRAM @ 32bit interface for proper operation. The TW2835 supports 8 channel display mode for display path and 4 channel for record path. The block diagram of video controller is shown in the following Fig 19.

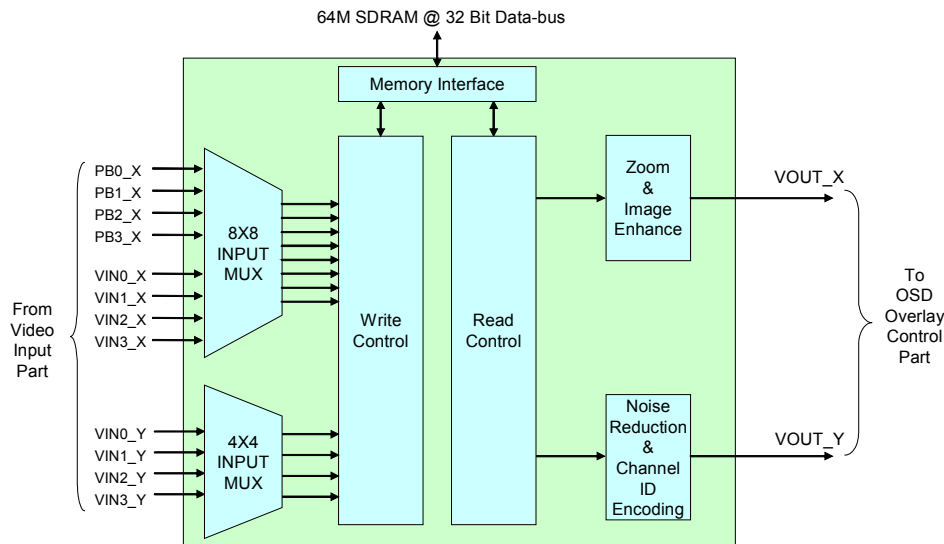

Fig 19 Block diagram of video controller

The TW2835 supports channel blanking, boundary on/off, blink, horizontal/vertical mirroring, and freeze function for each channel. The TW2835 can capture last 4 images automatically for each channel when video loss is detected.

The TW2835 has three operating modes such as live, strobe and switch mode. Each channel can be operated in its individual operating mode. That is, the TW2835 can be operated in multi-operating mode if each channel has different operating mode. Live mode is used to display real time video as QUAD or full live display, strobe mode is used to display non-realtime video with strobe signal from host and switch mode is used to display time-multiplexed video from several channels. For switch mode, the TW2835 supports two different types such as switch live and switch still mode.

The TW2835 also provides four record picture modes such as normal record mode and frame record mode and DVR normal record mode and DVR frame record mode. For record path, channel size and position have a limitation to half or full size in the horizontal and vertical direction.

For display path, the TW2835 can save and recall video through external extended SDRAM and support image enhancement function for non-realtime video such as freezing or playback video and provide high performance 2X zoom function. For record path, the TW2835 supports a noise reduction filter to reduce the compression data size and channel ID encoding that contains all current picture configurations.

The TW2835 also provides chip-to-chip cascade connection for 8 or 16 channel application.

Channel Input Selection

The channel for display path can select 1 input from 8 video inputs including 4 live video inputs and 4 playback inputs, but the channel for record path can choose 1 input from 4 live video inputs. The live video inputs can be selected via the DEC_PATH (0x80, 0x90, 0xA0, 0xB0 for display path, 1x60, 1x63, 1x66, 1x69 for record path) register and the playback inputs can be chosen via the PB_PATH_EN (1x10/13, 1x18/1B, 1x20/23, 1x28/2B) register. The Fig 20 shows the internal channel input selection.

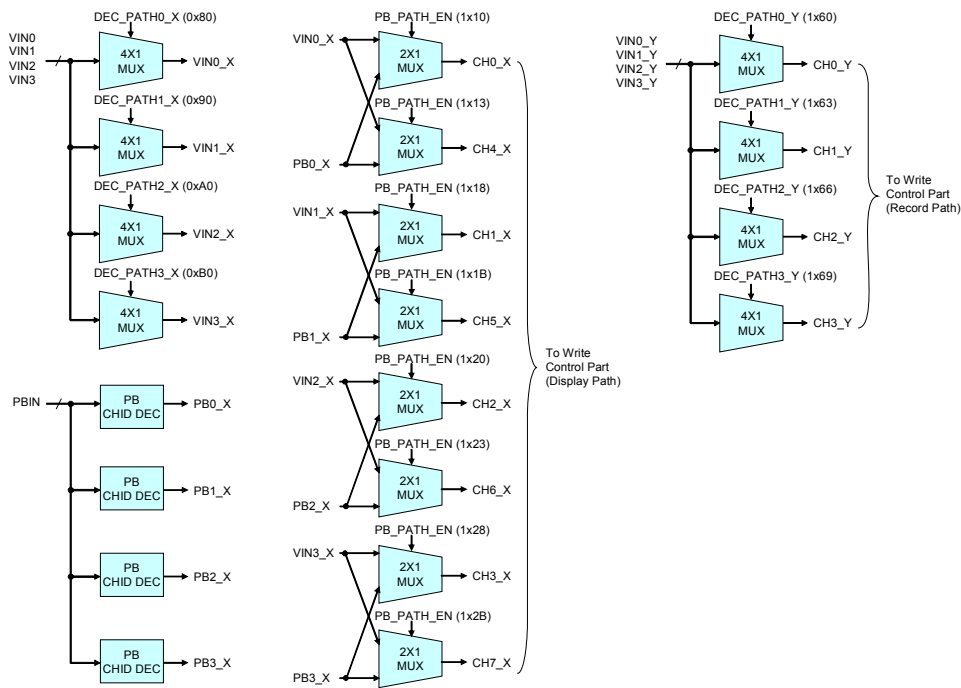

Fig 20 Channel input selection

Channel Operation Mode

Each channel can be working with three kinds of operating mode such as live, strobe and switch mode via the FUNC_MODE (1x10, 1x13, 1x18, 1x1B, 1x20, 1x23, 1x28, and 1x2B for display path, 1x60, 1x63, 1x66, and 1x69 for record path) register. The operation mode can be selected individually for each channel so that multi-operating mode can be implemented.

Live Mode

If FUNC_MODE is “0”, channel is operated in live mode. For the live mode, the video display is updated with real time. This mode is used to display a live video such as QUAD, PIP, and POP.

When changing the picture configuration such as input path, popup priority, PIP, POP, and etc, the TW2835 supports anti-rolling sequence by monitoring channel update with the STRB_REQ register (1x01 for display path, 1x54 for record path) after changing to strobe operation mode (FUNC_MODE = “1”). The following Fig 21 shows the sequence to change picture configuration.

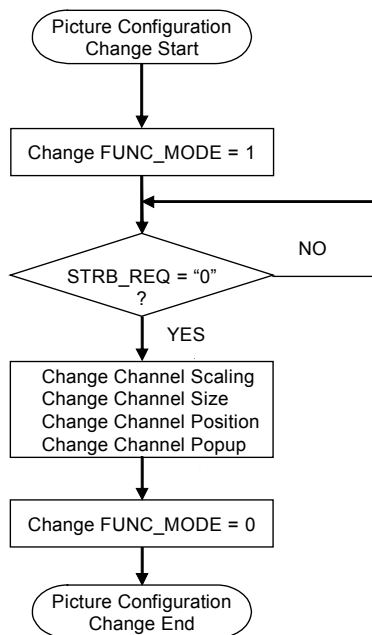

Fig 21 The sequence to change picture configuration

The status of STRB_REQ register can also be read through MPP1/2 pin with control of the MPPMD and MPPSET (1xB0, 1xB1, 1xB3, and 1xB5) register.

Strobe Mode

If FUNC_MODE is "1", channel is operated in strobe mode. For strobe mode, video display is updated whenever the TW2835 receives strobe command from host like CPU or Micom. If host doesn't send a strobe command to the TW2835 anymore, the channel maintains the last strobe image until getting a new strobe command. This mode is useful to display non-realtime video input such as playback video with multiplexed signal input and to implement pseudo 8 channel application or dual page mode or panorama channel display. Specially, the TW2835 supports easy interface for pseudo 8channel application that will be covered in display path control section. The TW2835 also supports auto strobe function for auto playback display that will be covered later in auto strobe function section.

Strobe operation is performed independently for each channel via the STRB_REQ (1x04, 1x54) register. But the STRB_REQ register has a different mode for reading and writing. Writing "1" into STRB_REQ in each channel makes the TW2835 updated by each incoming video. The updating status after strobe command can be known by reading the STRB_REQ register. If reading value is "1", updating is not completed after getting the strobe command. In that case, this channel cannot accept a new strobe command or a disabling strobe command from host. To send a new strobe command, host should wait until STRB_REQ state is "0". For freeze or non-strobe channel, the TW2835 can ignore the strobe command even though host sends it. In this case, the STRB_REQ register is cleared to "0" automatically without any updating video. The status of STRB_REQ register can also be read through MPP1/2 pin with control of the MPPSET (1xB3) register.

When updating video with a strobe command, the TW2835 supports field or frame updating mode via the STRB_FLD (1x04, 1x54) register. Odd field of input video can be updated and displayed for STRB_FLD = "0", even field for "1". For "2" of STRB_FLD register, the TW2835 doesn't care for even or odd field, and updates video by next any field. If the STRB_FLD register is "3", the strobe command updates video by frame. The following Fig 22 shows the example of strobe sequence for various STRB_FLD value.

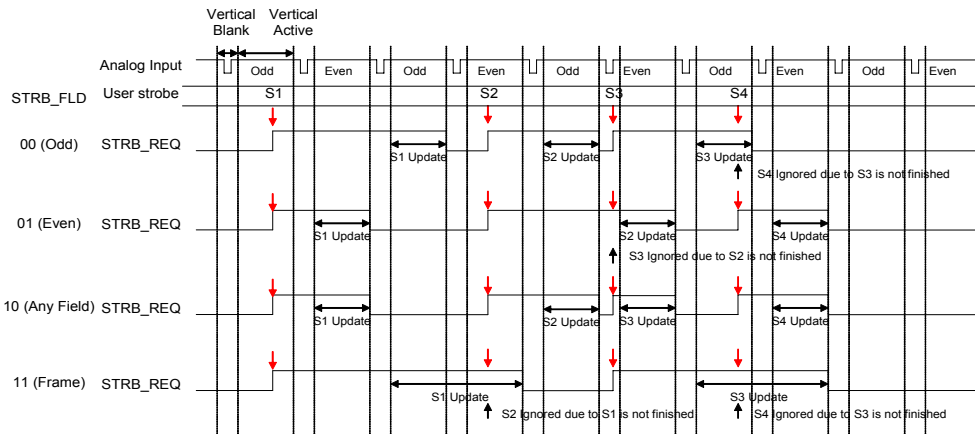

Fig 22 The example of strobe sequence for various STRB_FLD setting

The timing of strobe operation is related only with input video timing and strobe operation can be performed independently for each channel. So each channel is updated with different timing. The TW2835 provides a special feature as dual page mode using the DUAL_PAGE (1x01, 1x54) register. Although each channel is updated with different time, all channels can be displayed simultaneously in dual page mode. This means that the TW2835 waits until all channels are updated and then displays all channels with updated video at the same time. When dual page mode is enabled, host should send a strobe command for all channels and host should wait until all channels complete their strobe operations to send a new strobe command. The Fig 23 shows the example of 4 channel strobe sequences for dual page.

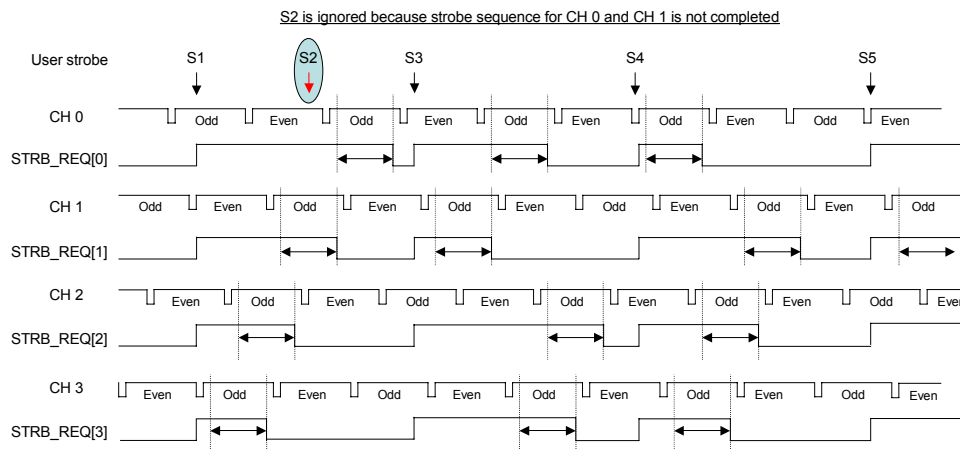

Fig 23 The example of 4 channel strobe sequences for dual page mode

Switch Mode

If FUNC_MODE is “2”, channel is operated in switch mode. The TW2835 supports 2 different switching types such as still switching and live switching mode via the MUX_MODE (1x06, 1x56) register. For still switching mode, the TW2835 maintains the switched channel video as still image until next switching request, but for live switching mode the TW2835 updates every field of switched channel until next switching request. The live switching mode is used for channel sequencer without any timing loss or disturbing. In switch mode, there is a constraint that the picture size of all switched channel should be same even though their size can be varied. The TW2835 can switch the channel by fields or frames that can be programmed up to 1 field or 1 frame rate. But if the channel is on freeze state, skip mode or disabled, the TW2835 ignores the request for switch mode.

Switch Trigger Mode

To operate the switching function properly, the channel switching should be requested with triggering that has three kinds of mode such as internal triggering from internal field counter, external triggering from external host or pin and interrupted triggering like alarm. The triggering mode can be selected by the TRIG_MODE (1x56) register. The TW2835 supports all triggering mode in record path, but provides only interrupt triggering mode in display path.

The TW2835 contains 128 depth internal queues that have channel sequence information with internal or external triggering. Actual queue size can be defined by the QUE_SIZE (1x57) register. The channel switching sequence in the internal queue is changed by setting “1” to QUE_WR (1x5A) register after defining the queue address with the QUE_ADDR (1x5A) register and the channel switching information with the MUX_WR_CH (1x59) register. The QUE_WR register will be cleared automatically after updating queue. The channel sequence information can be read via the CHID_MUX_OUT (1x0A for display path, 1x5E for record path) register. The following Fig 24 shows the structure of switching operation.

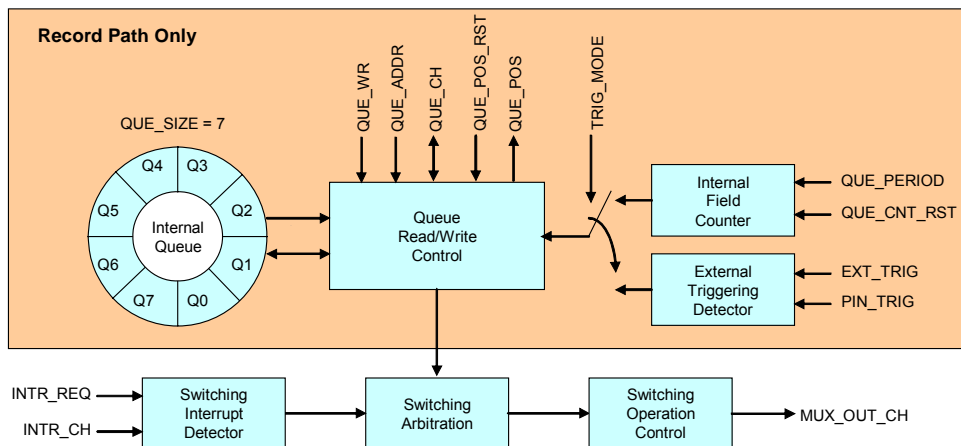

Fig 24 The structure of switching operation when QUE_SIZE = 7

For internal triggering mode, the switching period can be specified in the QUE_PERIOD (1x58) register that has 1 ~ 1024 field range. The internal field counter can be reset at anytime using the QUE_CNT_RST (1x5B) register and restarted automatically after reset. To reset an internal queue position, set "1" to QUE_POS_RST (1x5B) register and then the queue position will be restarted after reset. Both QUE_CNT_RST and QUE_POS_RST register can be cleared automatically after set to "1". The following Fig 25 shows an illustration of QUE_POS_RST and QUE_CNT_RST. The next queue position can be read via the QUE_ADDR (1x5A) register.

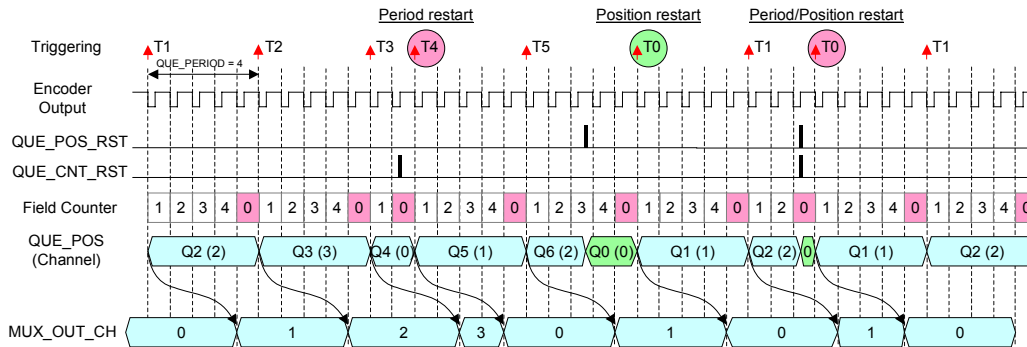

Fig 25 The illustration of QUE_POS_RST and QUE_CNT_RST

For external triggering mode, the request of channel switching comes from the EXT_TRIG (1x59) register or TRIGGER pin that is controlled by the PIN_TRIG_MD (1x56) register. Like internal triggering mode, writing "1" to the QUE_POS_RST register can reset the queue position in external triggering mode.

For interrupt triggering, host can request the channel switching at anytime via the INTR_REQ (1x07, 1x59) register. The switching channel is defined by the INTR_CH (1x07 for display path) or MUX_WR_CH (1x59 for record path) registers. Because the interrupted trigger has a priority over internal or external triggering in record path, the channel defined by the MUX_WR_CH can be inserted into the programmed channel sequence immediately.

Switching Sequence

The TW2835 also provides various switching types as odd field, even field or frame switching via the MUX_FLD (1x06, 1x56) register. For MUX_FLD = "0", it is working as field switching mode with only odd field, but with only even field for MUX_FLD = "1". For MUX_FLD = "2" or "3", it is working as frame switching with both odd and even field.

Actually the channel switching is executed just before vertical sync of video output in field switching mode or before vertical sync of only odd field in frame switching mode. So all register

for switching should be set before that time. Otherwise, the control values will be applied to the next field or frame. Likewise, the switching channel information is updated just before vertical sync of video output in field switching or before vertical sync of only odd field in frame switching mode.

Basically the switching sequence takes 4 field duration to display the switching channel from any triggering (field or frame). The host can read the current switching channel information through the MUX_OUT_CH (1x08, 1x6E) register. The TW2835 also supports external pin output for this channel information with DLINKI and MPP1/2 pin via the MPP_MD and MPP_SET (1xB0, 1xB1, 1xB3, and 1xB5) register. The switching channel information can also be discriminated by the channel ID in the video stream. The following Fig 26 shows the illustration of channel switching with internal triggering.

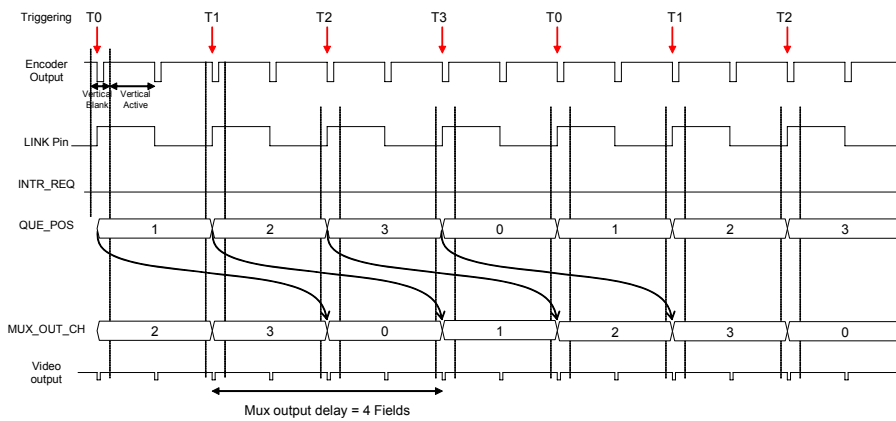

Fig 26 The illustration of switching sequence when QUE_SIZE = 3, QUE_PERIOD = 1

The following Fig 27 shows the illustration of channel switching with the combination of internal triggering and interrupted triggering mode.

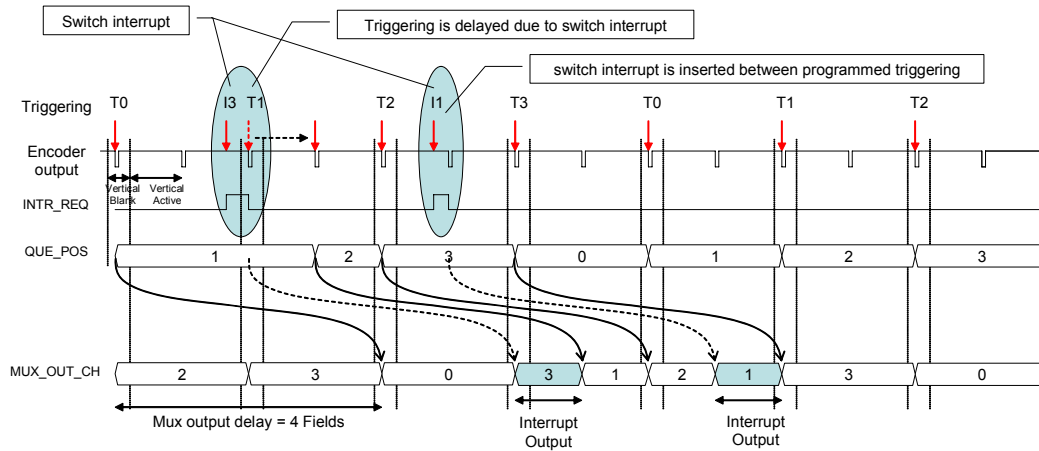

Fig 27 The interrupted switching sequence when QUE_SIZE = 3, QUE_PERIOD = 1

The TW2835 supports the skip function of the switching queue for switch mode in record path. In single chip application, the auto skip function of the switching queue can be supported if the MUX_SKIP_EN (1x5B) register is "1" and the NOVID_MODE is "1" or "3". But in the chip-to-chip cascaded application, the skip function should be forced with the MUX_SKIP_CH (1x5C, 1x5D) register because the switching queue for whole channels is located in the lowest slaver device but cannot get the no-video information from the other chips. The QUAD MUX function in chip-to-chip cascade application will be covered in the "Chip-to-Chip Cascade Operation (page 76)".

Channel Attribute

The TW2835 provides various channel attributes such as channel enabling, popup enabling, boundary selection, blank enabling, freeze, horizontal/vertical mirroring for both display and record path. As special feature, the TW2835 supports the last image capture function, save and recall function, image enhancement and playback input selection for display path. For last image capture mode, channel can be blanked or boundary can be blinked automatically on video loss state.

Background Control

Summation of all active channel regions can be called as active region and the rest region except active region is defined as background region. The TW2835 supports background overlay and the overlay color is controlled via the BGDCOL (1x0F, 1x5F) register.

Boundary Control

The TW2835 can overlay channel boundary on each channel region using the BOUND (1x11, 1x14, 1x19, 1x1C, 1x21, 1x24, 1x29, and 1x2C for display path, 1x61, 1x64, 1x67, and 1x6A for record path) register and it can be blinked via the BLINK (1x11, 1x14, 1x19, 1x1C, 1x21, 1x24, 1x29, and 1x2C for display path, 1x61, 1x64, 1x67, and 1x6A for record path) register when BOUND is high. The boundary color of channel can be selected through the BNDCOL (1x0F, 1x5F) register. The blink period can be also controlled through the TBLINK (1x01, 1x52) register.

Blank Control

Each channel can be blanked with specified color using the BLANK (1x11, 1x14, 1x19, 1x1C, 1x21, 1x24, 1x29, and 1x2C for display path, 1x61, 1x64, 1x67, and 1x6A for record path) register and the blank color can be specified via the BLKCOL (1x0F, 1x3F) register.

Freeze Control

Each channel can capture last 4 field images whenever freeze function is enabled and display 1 field image out of the captured 4 field images using the FRZ_FLD (1x0F, 1x3F) register. The freeze function can be enabled or disabled independently for each channel via the FREEZE (1x11, 1x14, 1x19, 1x1C, 1x21, 1x24, 1x29, and 1x2C for display path, 1x61, 1x64, 1x67, and 1x6A for record path) register. The TW2835 also supports frame freeze function via the FRZ_FRAME (1x01, 1x52) register, and 1 frame image out of the captured 2 frame images using the FRZ_FLD (1x0F, 1x3F) register.

Last Image Captured

When video loss has occurred or gone, the TW2835 provides 4 kinds of indication such as bypass of incoming video, channel blank, capture of last image, and capture of last image with blinking channel boundary depending on the NOVID_MODE (1x05, 1x55) register. This function is working automatically on video loss. The capturing last image is same as freeze function described above. User can select 1 field image out of captured 4 field images via the FRZ_FLD (1x0F, 1x5F) register which is shared with freeze function. The TW2835 has frame freeze function via the FRZ_FRAME (1x01, 1x52) register, and 1 frame image out of the captured 2 frame images using the FRZ_FLD (1x0F, 1x3F) register.

Horizontal / Vertical Mirroring

The TW2835 supports image-mirroring function for horizontal and/or vertical direction. The horizontal mirroring is achieved via the H_MIRROR (1x11, 1x14, 1x19, 1x1C, 1x21, 1x24, 1x29, and 1x2C for display path, 1x61, 1x64, 1x67, and 1x6A for record path) register and the vertical mirroring is attained via the V_MIRROR (1x11, 1x14, 1x19, 1x1C, 1x21, 1x24, 1x29, and 1x2C for display path, 1x61, 1x64, 1x67, and 1x6A for record path) register. It is useful for a reflection image in the horizontal and vertical direction from dome camera or car-rear vision system.

Field to Frame Conversion

If the displayed channel size is half size of the video input in vertical direction, the video input can be separated into two (odd/even) fields according to the line numbers such as odd line for odd field and even line for even field. With this conversion, the vertical resolution of the video input can be enhanced compared with simple half vertical scaling, but the field rate is reduced to half. This mode can be enabled via the FIELD_OP (1x12, 1x15, 1x1A, 1x1D, 1x22, 1x25, 1x2A, and 1x2D for display path, 1x62, 1x65, 1x68 and 1x6B for record path) register.

Display Path Control

The TW2835 can save images in external memory and recall them to display. This function can be working in display path. The TW2835 also supports the special filter to enhance image quality in display path for non-realtime video display such as frozen image, recalled image from saved images or playback input with multiplexed video source. The TW2835 provides high performance 2X zoom function in the vertical and horizontal direction.

The TW2835 supports any kind of picture configuration for display path with arbitrary picture size, position and pop-up control. The TW2835 also provides 8 channel display function for full triplex application (Display + Record + Playback) and the pseudo 8ch display function for non-realtime application.

Save and Recall Function

The save/recall function can be working independently for each channel and the number of the saved images depends on the picture size and field type. The TW2835 can save image only in live channel so that it cannot be saved in frozen channel. If channel is working on strobe operating mode, this channel can be saved with new strobe command. For switch operating mode, the channel can be saved only on switching time because this channel can be updated at this moment. **But, the save function cannot be working simultaneously with 1 ~ 5 frame bitmap page mode because both regions are overlapped with each other.**

To save image, several parameters should be controlled that are the SAVE_FLD, SAVE_HID, SAVE_ADDR (1x02) and SAVE_REQ (1x03) registers. The SAVE_FLD determines field or frame type for image to be saved. Even though the channel to be saved is hidden by upper layer picture, it can be saved using the SAVE_HID register that makes no effect on current display. The saving function is requested by writing "1" to the SAVE_REQ register and this register will be cleared when saving is done. Before it is cleared, the TW2835 cannot accept new saving request. The SAVE_ADDR register defines address where an image will be saved. Because 4M bits is allocated for each 1 field image, SAVE_ADDR can have range with 4 ~ 11 because the first 0~ 3 and last 12 ~ 15 addresses are reserved for normal operation so that it cannot be used for saving function.

To recall the saved video image, several parameters are required such as RECALL_FLD (1x03), RECALL_EN (1x11, 1x14, 1x19, 1x1C, 1x21, 1x24, 1x29, 1x2C) and RECALL_ADDR (1x12, 1x15, 1x1A, 1x1D, 1x22, 1x25, 1x2A, 1x2D) registers. If the RECALL_EN is "1", the TW2835 recalls the saved image that is located at the RECALL_ADDR in external memory and displays it just like incoming video. The RECALL_FLD register determines 1 field or 1 frame mode to display.

The following Fig 28 illustrates the relationship between external SDRAM size and SAVE_ADDR / RECALL_ADDR.

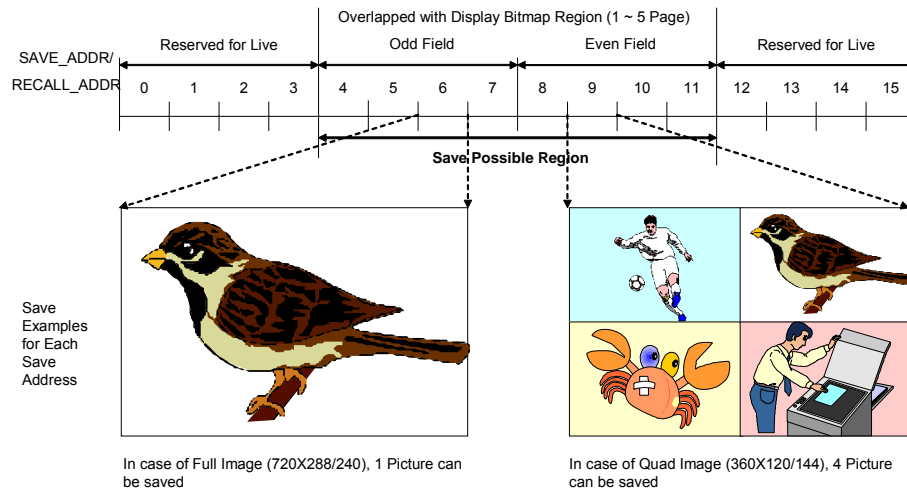

Fig 28 The relationship between SDRAM size and image Size

Image Enhancement

In non-realtime video such as frozen image, recalled image from saved images and playback input with multiplexed video source, the line flicker noise can be found in image because it displays same field image for both odd and even field. The embedded filter in the TW2835 can remove effectively this line flicker noise and be enabled via the ENHANCE (1x11, 1x14, 1x19, 1x1C, 1x21, 1x24, 1x29, 1x2C) register for each channel. This filter coefficient can be controlled via the FR_EVEN_OS and FR_ODD_OS (1x0B) register. The TW2835 also supports an automatic image enhancement mode via the AUTO_ENHANCE (1x05) register that is checking the channel operation mode such as recalling the saved or frozen image and then enabling the enhancement filter.

Zoom Function

The TW2835 supports high performance 2X zoom function in the vertical and horizontal direction for display path. The zoom function can be working in any operation mode such as live, strobe and switch mode. Conventional system also has zoom function, but it has a very poor quality due to line flicker noise even though interpolation filter is adapted. The TW2835 provides high quality zoom characteristics using a high performance interpolation filter and image enhancement technique. When zoom is executed, the image enhancement is operated automatically and the zoom filter coefficient can be controlled via the ZM_EVEN_OS and ZM_ODD_OS (1x0B) register.

The zoomed region will be defined with the ZOOMH (1x0D) and ZOOMV (1x0E) registers and can be displayed via the ZMBNDCOL, ZMBNDEN, ZMAREAEN, ZMAREA (1x0C) register. The zoom operation is enabled via the ZMENA (1x0C) register.

The TW2835 also supports only horizontal direction zoom via the H_ZM_MD (1x0C) register. This mode is useful to display full size from playback input with CIF format (360x240 @ NTSC, 360x288 @ PAL). In this mode, ZOOMV register is useless because vertical direction has no meaning in this mode.

Picture Size and Popup Control

Each channel region can be defined using its own PICHL (1x30, 1x34, 1x38, 1x3C, 1x40, 1x44, 1x48, and 1x4C), PICHR (1x31, 1x35, 1x39, 1x3D, 1x41, 1x45, 1x49, and 1x4D), PICVT (1x32, 1x36, 1x3A, 1x3E, 1x42, 1x46, 1x4A, and 1x4E), and PICVB (1x33, 1x37, 1x3B, 1x3F, 1x43, 1x47, 1x4B, and 1x4F) register. If more than 2 channels have same region, there will be a conflict of what to display for that area. Generally the TW2835 defines that the channel 0 has priority over channel 7. So if a conflict happens between more than 2 channels, the channel 0 will be displayed first as top layer and then channel 1 and 2 and 3 are hidden beneath.

The TW2835 also provides a channel pop-up attribute via the POP_UP (1x10, 1x13, 1x18, 1x1B, 1x20, 1x23, 1x28, and 1x2B) register to give priority for another display. If a channel has pop-up attribute, it will be displayed as top layer. This feature is used to configure PIP (Picture-In-Picture) or POP (Picture-Out-Picture). The following Fig 29 shows the channel definition and priority for display path.

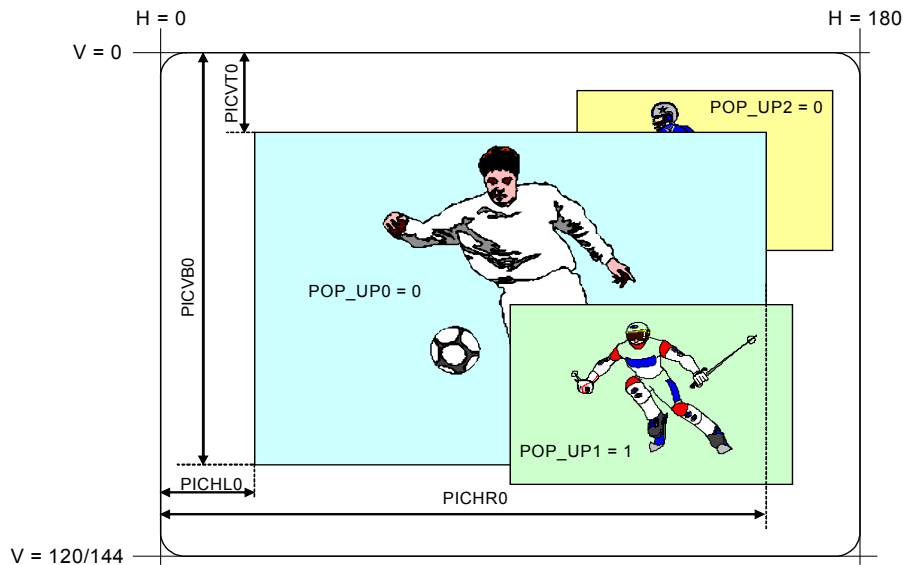

Fig 29 The channel position and priority in display path

Full Triplex Function

The TW2835 provides a full triplex function that implies to support four channel live, four channel playback display and four channel record output. The playback input is selected via the PB_PATH_EN (1x10, 1x13, 1x18, 1x1B, 1x20, 1x23, 1x28, and 1x2B) register for display path and the selected channel is updated automatically from the channel ID decoder via the PB_CH_NUM (1x16, 1x1E, 1x26, and 1x2E) register. The auto-cropping and auto-strobe mode is very useful to display the playback input with multiplexed or dual page video format. (A detailed description for playback path is referred to “Playback Path Control” Chapter, page 57)

The TW2835 also supports pseudo 8 channel display mode with any picture configuration for non-realtime application. The TW2835 has a respective strobe request bit for each channel (STRB_REQ, 1x03 register) so that the channel is updated easily by host after the analog switch is changed. The following Fig 30 shows an illustration of pseudo 8-channel system.

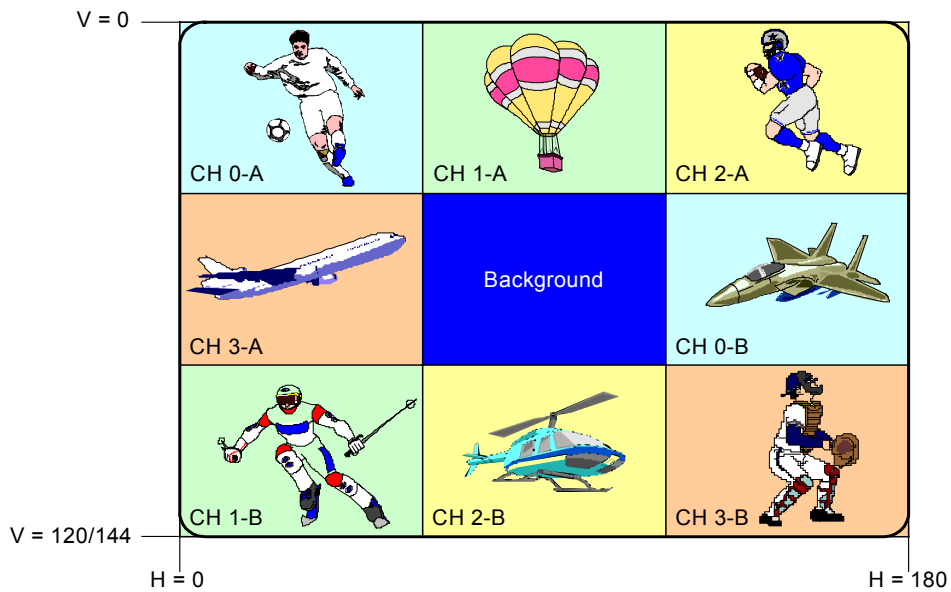

Fig 30 Pseudo 8 channel display operation

Playback Path Control

The TW2835 supports the playback function for variable record mode input such as normal record mode, frame record mode, DVR normal record mode, and DVR frame record mode. The TW2835 also provides auto cropping and auto strobe function for playback input through auto channel ID decoding. The auto strobe function implies that the selected channel is updated automatically from the playback input of the time-multiplexed full D1, CIF or Quad record format.

If the channel operation mode is live mode (FUNC_MODE = "0"), the playback input can be bypassed in display path, but the auto cropping function from the channel ID decoder is available to separate each channel from the multi-channel format such as QUAD (Auto cropping function is described in "Cropping Function" section, page 34). The displayed channel can be selected via the PB_CH_NUM (1x16, 1x1E, 1x26, and 1x2E) register.

If the channel operation mode is strobe mode (FUNC_MODE = "1"), the auto strobe function is used to update the channel automatically for the playback input of the time-multiplexed full D1, CIF or Quad record format through channel ID decoder. The auto strobe function is enabled by the PB_AUTO_EN (1x16) and PB_CH_NUM (1x16, 1x1E, 1x26, and 1x2E) register and can also be used for pseudo 8 channel display of playback input with the dual page mode or pseudo 8 channel MUX mode.

The TW2835 supports event strobe mode with event information in auto channel ID. It makes the channel updated whenever event information in auto channel ID is detected. The event strobe mode can be enabled via the EVENT_PB (1x16, 1x1E, 1x26, and 1x2E) register.

The TW2835 provides an anti-rolling function for the case of changing the picture configuration in playback application through the PB_STOP (1x16, 1x1E, 1x26, and 1x2E) register. If the PB_STOP is set to high in strobe operation mode (FUNC_MODE = "1"), the channel is not updated until the PB_STOP is set to low after picture configuration is changed.

To remove the image shaking from the playback input of frame switching mode, the TW2835 also supports frame to field conversion in auto strobe mode via the FLD_CONV (1x16, 1x1E, 1x26, and 1x2E) register. It makes the channel updated with only 1 field even though the playback input is made up of frame.

Normal Record Mode

The TW2835 provides various playback functions for normal record mode input. For playback input of live mode, the FUNC_MODE should be set to “0” and then it can be bypassed and displayed in live mode. For playback input of multiplexed record format, the FUNC_MODE should be set into “1” and then the auto strobe function is used for automatic display of the selected channel. . The following Fig 31 shows the examples of playback function for normal record mode using bypass, auto cropping, scaling, repositioning, and popup control.

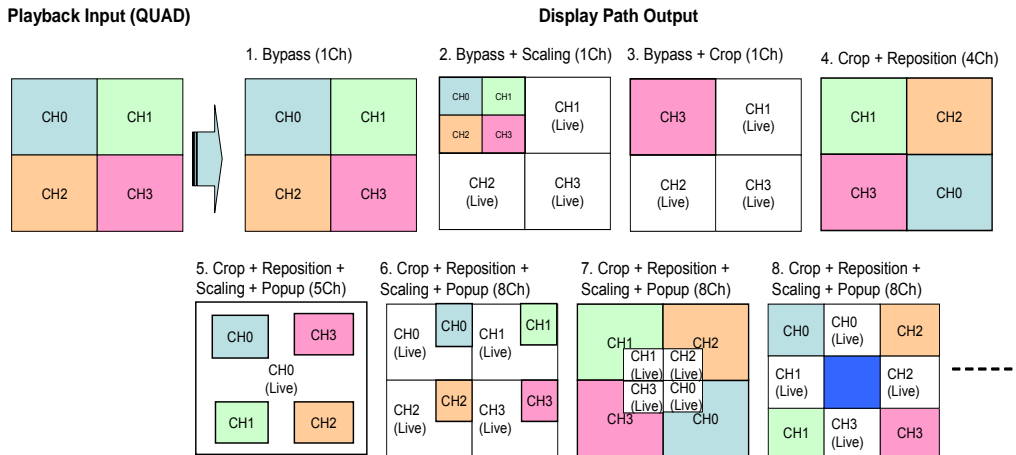

Fig 31 The examples of the playback function for normal record mode

The following Fig 32 shows the various display examples for various playback input format using auto strobe function.

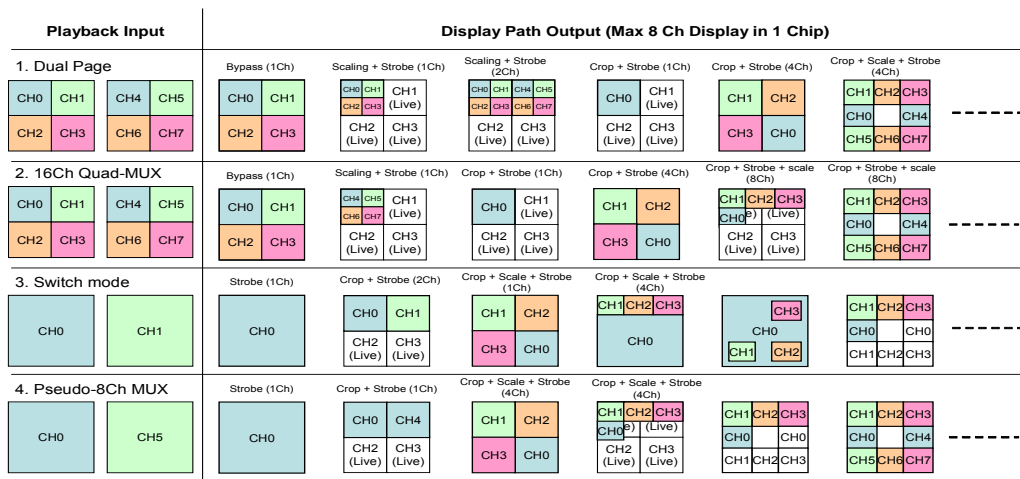

Fig 32 The example of auto strobe function for normal record mode

Frame Record Mode

The TW2835 supports the playback function for frame record mode input. The playback input of frame record mode is formed with 1 frame so that the vertical lines of each playback channel have twice as many as the normal record mode. So if the displayed channel size is half size of the playback input in vertical direction, the playback input can be separated into two (odd/even) fields according to the line numbers such as odd line for odd field and even line for even field. With this conversion, the vertical resolution of the playback input can be enhanced compared with simple half vertical scaling of the playback input. This mode can be enabled via the FIELD_OP (1x12, 1x15, 1x1A, 1x1D, 1x22, 1x25, 1x2A, and 1x2D) register.

The following Fig 33 shows the various display examples with auto cropping, auto strobe, and scaling function for playback input using frame record mode.

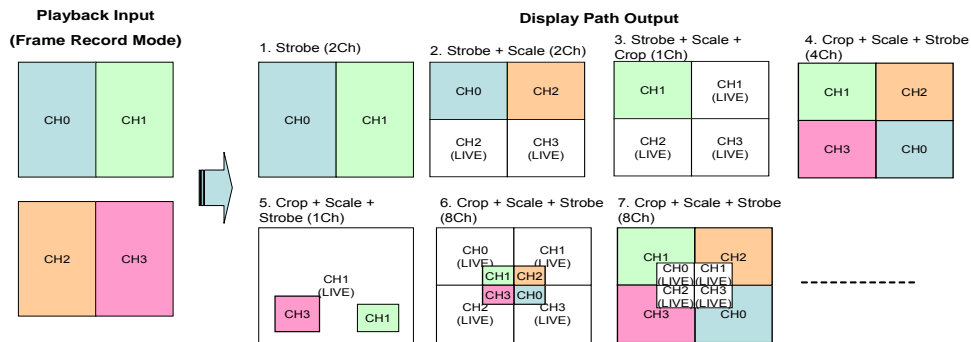

Fig 33 The examples of the playback function for frame record mode

The following Fig 34 shows the illustration of this conversion from frame record mode to normal display mode in playback application.

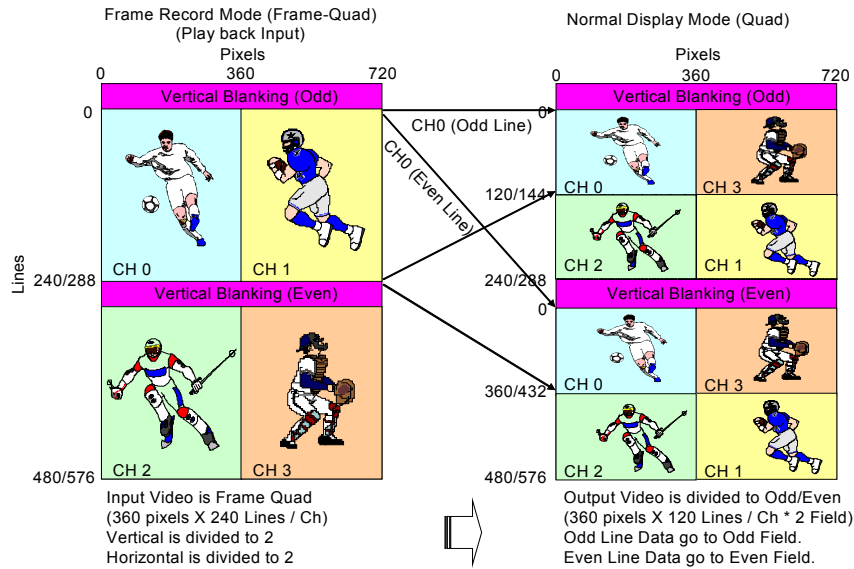

Fig 34 The conversion from frame record mode to normal display mode

The TW2835 also supports only horizontal zoom mode via the H_ZM_MD (1x0C) register. This mode is useful to display the playback input of frame record mode to full size image. The following Fig 35 shows the illustration of this conversion in playback application.

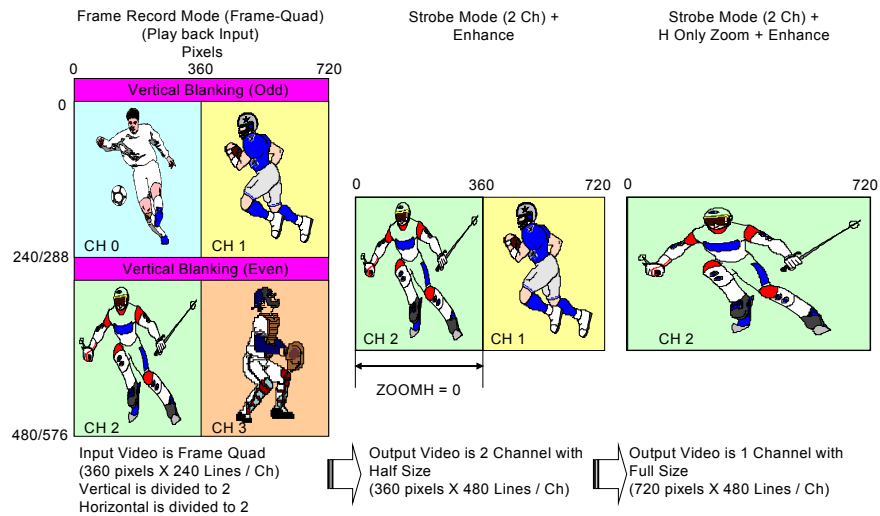

Fig 35 The conversion from frame record mode to full image

DVR Normal Record Mode

If the playback input is the DVR normal record mode, it cannot be displayed directly because it is special mode not for display but for record to compression part. The TW2835 supports the conversion from this DVR normal record mode to normal display mode via the DVR_IN (1x12, 1x15, 1x1A, 1x1D, 1x22, 1x25, 1x2A, and 1x2D) register. For auto cropping function of the playback with this mode, the PB_CROP_MD (0x38) register should be set into "1" to crop the 1/4 vertical picture size (Please refer to "Cropping and Scaling Function for Playback" section in Page 34).

The following Fig 36 shows the illustration of conversion from DVR normal record mode to normal display mode in playback application.

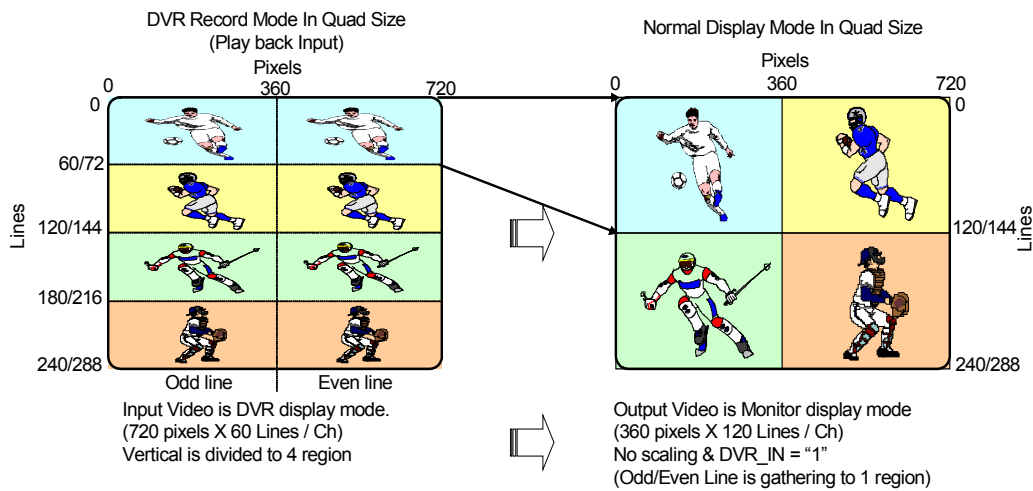

Fig 36 The conversion from DVR normal record mode to normal display mode

The TW2835 supports all channel attributes in this mode except the scaling function for vertical direction. So the picture size in this mode will be fixed to Quad (360x120).

DVR Frame Record Mode

The TW2835 also provides the conversion from DVR frame record mode to normal display mode using combination of frame record mode and DVR normal record mode via the DVR_IN and FIELD_OP (1x12, 1x15, 1x1A, 1x1D, 1x22, 1x25, 1x2A, and 1x2D) register. The following Fig 37 shows the illustration of conversion from DVR frame record mode to normal display mode in playback application.

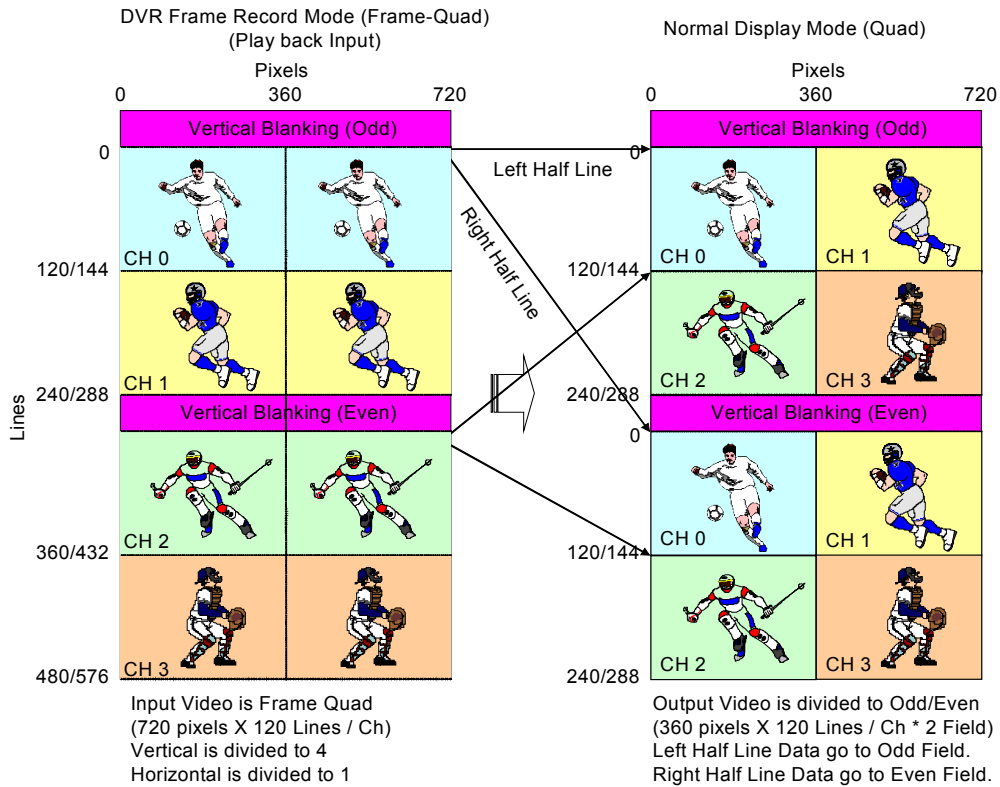

Fig 37 The conversion from DVR frame record mode to normal display mode

Like DVR normal record mode, all channel attributes can be supported, but the scaling function cannot be supported in this mode. So the channel size will be fixed to Quad size. To implement PIP or POP application with smaller size than Quad, only odd line data is used with channel size definition, scaling and enhancement function.

Like frame record mode, the only horizontal zoom mode is useful to display the playback input of DVR frame record mode to full size image via the DVR_IN and H_ZM_MD (1x0C) register. The following Fig 38 shows the illustration of this conversion from DVR frame record mode to normal display mode for full image in playback application.

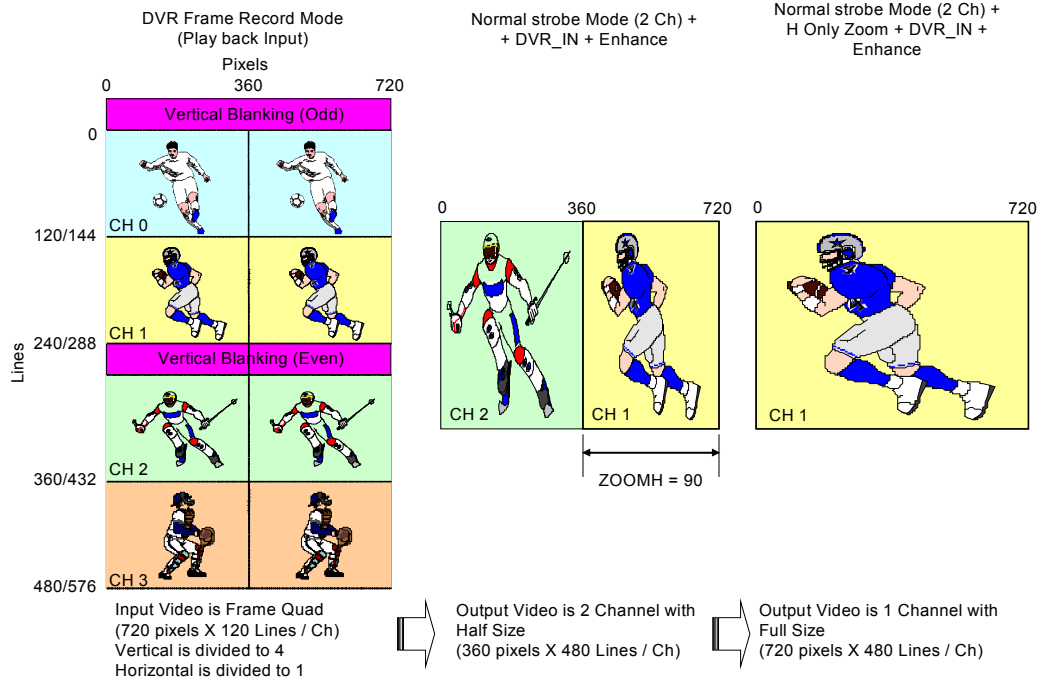

Fig 38 The conversion from DVR frame record mode to normal display mode for full image

Record Path Control

The TW2835 supports 4 record modes such as normal record mode, frame record mode, DVR record mode and DVR frame record mode. The DVR record mode and DVR frame record mode generate continuous video stream for each channel and transfer it to compression part (M-JPEG or MPEG) so that they are very useful for DVR application. The frame record mode can be used to record each channel with full vertical resolution. Especially the TW2835 includes a noise reduction filter in record path so that it can reduce spot noise and then provide less compression file size.

The record mode is selected via the DIS_MODE and FRAME_OP (1x51) register. If the FRAME_OP is "0", the DIS_MODE = "0" stands for normal record mode and the DIS_MODE = "1" represents DVR record mode. If the FRAME_OP is "1", the DIS_MODE = "0" stands for frame record mode and the DIS_MODE = "1" represents DVR frame record mode.

The TW2835 supports high performance free scaler vertically and horizontally in display path, but has the size and position limitation such as Full / Quad / CIF in record path. The TW2835 also provides four channel real-time record mode with full D1 format using DLINKI and MPP1/2 pin.

Normal Record Mode

Each channel position and size can be defined using its own PIC_SIZE (1x6C), and PIC_POS (1x6D) register. The channel size is defined via the PIC_SIZE register such as “0” for horizontal and vertical half size (QUAD), “1” for horizontal full size and vertical half size, “2” for horizontal half size and vertical full size, and “3” for horizontal and vertical full size. The channel position is defined via the PIC_POS register such as “0” for no horizontal and vertical offset, “1” for only horizontal half offset, “2” for only vertical half offset, and “3” for horizontal and vertical half offset. The channel size and location should be defined within the full picture size. (i.e. PIC_SIZE = “3” & PIC_POS = “2” is not allowed)

The horizontal full size of picture is controlled via the SIZE_MODE (1x51) register such as “0” for 720 pixels, “1” for 702 pixels, and “2” for 640 pixels. Likewise, the vertical full size is selected by the SYS5060 (1x00) register such as “0” for 240 lines and “1” for 288 lines.

If more than 2 channels have same region, there will be a conflict of what to display for that area. Generally the TW2835 defines that the channel 0 has priority over channel 3. So if a conflict happens between more than 2 channels, the channel 0 will be displayed first as top layer and then the channel 1, 2 and 3 are hidden beneath. The TW2835 also provides a channel pop-up attribute via the POP_UP (1x60, 1x63, 1x66, and 1x69) register to give priority for another display. If a channel has pop-up attribute, it will be displayed as top layer. The following Fig 39 shows the example of the channel position and size control in normal record mode.

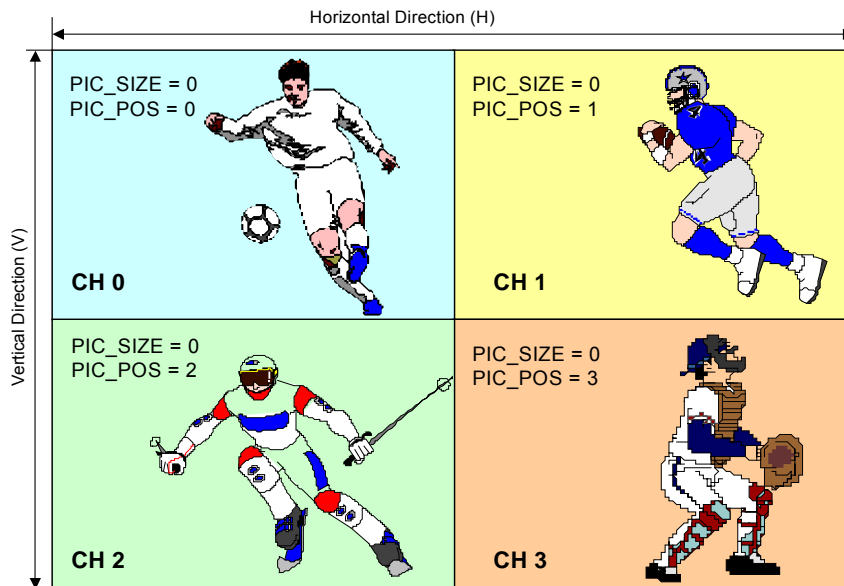

Fig 39 The channel position and size control in normal record mode

Frame Record Mode

The frame record mode is similar to normal record mode except that the definition of picture size is extended to frame area and only one field data can be output in 1 frame. The odd or even field selection is controlled via the FRAME_FLD (1x51) register. Like normal record mode, each channel position and size are defined using its own PIC_SIZE (1x6C), and PIC_POS (1x6D) register. The channel size is defined via the PIC_SIZE register such as “0” for horizontal half size and vertical full size, “1” for horizontal and vertical full size, but “2” or “3” is not allowed. That is, the channel size for vertical direction supports only one field size. The channel position is defined via the PIC_POS register such as “0” for no horizontal and vertical offset, “1” for only horizontal half offset, “2” for only vertical 1 field offset, and “3” for horizontal half picture offset and vertical 1 field offset. The channel size and location should be defined within the full picture size. In frame record mode, the TW2835 also supports the full operation mode such as live, strobe or switch operation and provides a pop-up attribute via the POP_UP register. The Fig 40 shows the example of the channel position and size control in frame record mode.

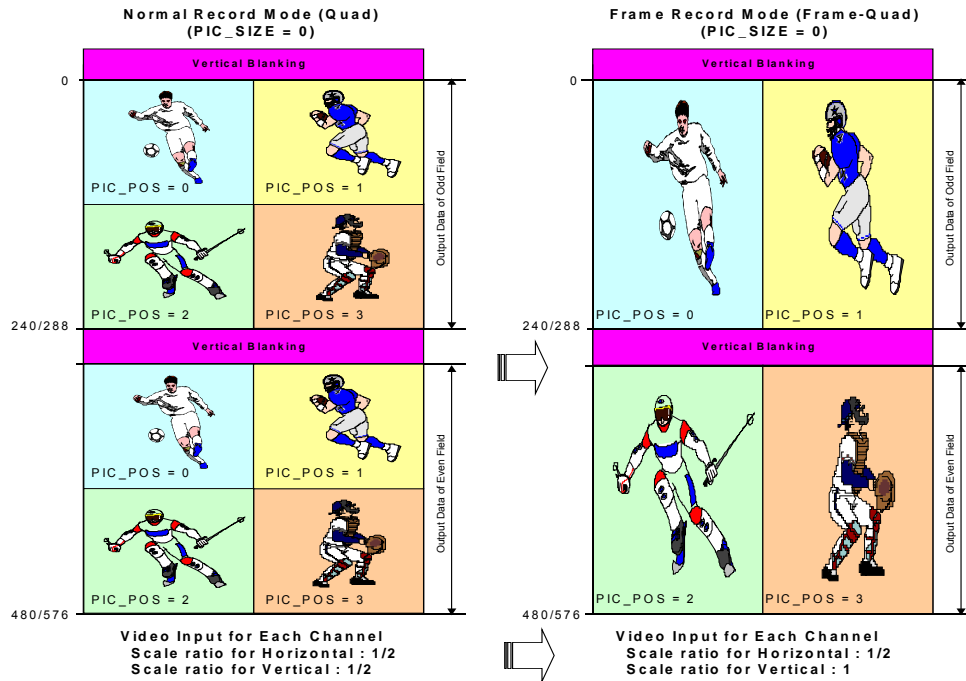

Fig 40 The channel position and size control in frame record mode

DVR Normal Record Mode

The DVR normal record mode outputs the continuous video stream for compression part (M-JPEG or MPEG) in DVR application. Like normal record mode, each channel position and size can be defined using its own PIC_SIZE (1x6C), and PIC_POS (1x6D) register.

The channel size is defined via the PIC_SIZE register such as “0” for horizontal and vertical half size (QUAD), “1” for horizontal full size and vertical half size, “2” for horizontal half size and vertical full size, and “3” for horizontal and vertical full size. The channel position is defined via the PIC_POS register such as “0” for no vertical offset, “1” for vertical 1/4 picture offset, “2” for vertical 1/2 picture offset and “3” for vertical 3/4 picture offset. The channel size and location should be defined within the full picture size. In DVR normal record mode, the TW2835 also supports the full operation mode such as live, strobe or switch operation and provides a pop-up attribute via the POP_UP register. But the channel boundary is not supported in DVR normal record mode. The following Fig 41 shows the example of the channel position and size control in DVR normal record mode.

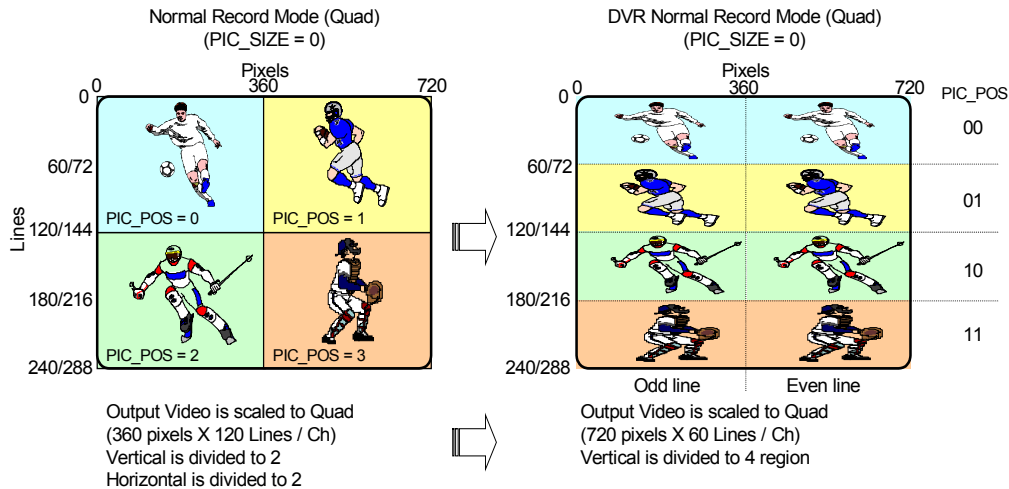

Fig 41 The channel position and size control for DVR normal record mode

DVR Frame Record Mode

The DVR frame record mode is the combination of frame record mode and DVR normal record mode. The odd or even field selection is controlled via the FRAME_FLD (1x51) register like frame record mode. The TW2835 also supports the full operation mode such as live, strobe or switch operation, but the channel boundary is not supported in DVR frame record mode.

Like frame record mode, each channel position and size can be defined using its own PIC_SIZE (1x6C), and PIC_POS (1x6D) register. The channel size is defined via the PIC_SIZE register such as “0” for horizontal half size and vertical full size, “1” for horizontal and vertical full size, but “2” or “3” is not allowed. The channel position is defined via the PIC_POS register such as “0” for no horizontal and vertical offset, “1” for vertical half offset, “2” for vertical 1 field offset, and “3” for vertical 1 and half field offset. The channel size and location should be defined within the full picture size. The following Fig 42 shows the example of DVR frame record mode.

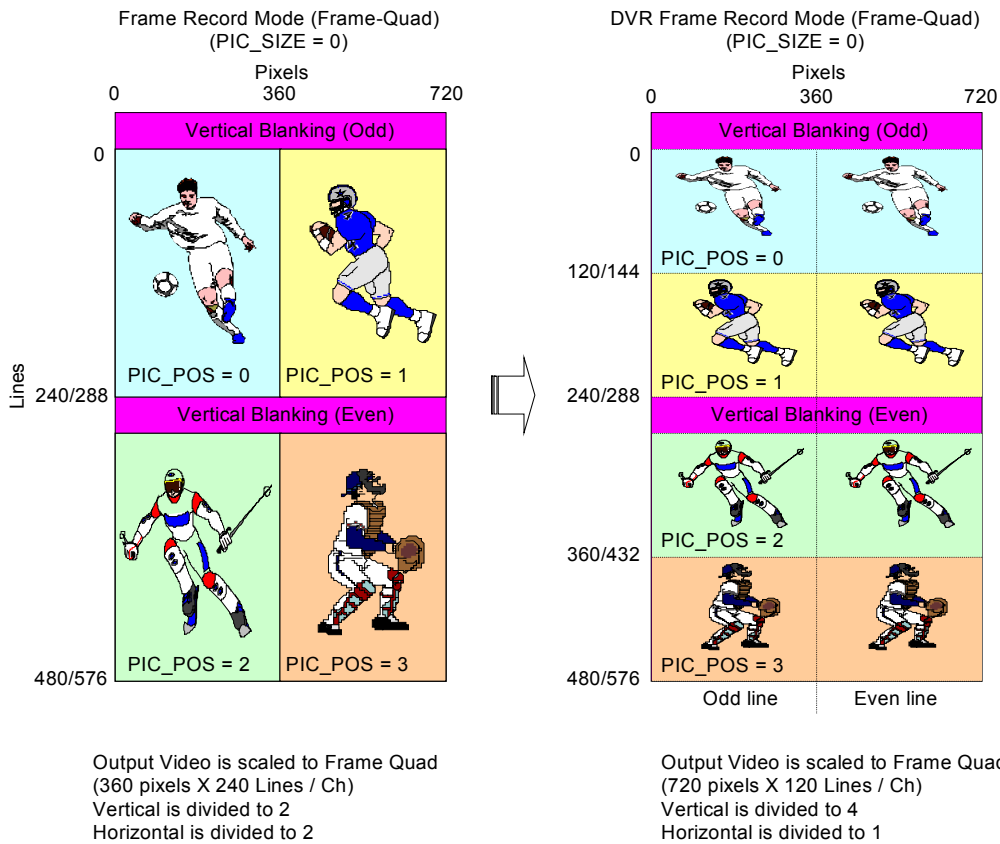

Fig 42 The channel position and size control for DVR frame record mode

Noise Reduction

The TW2835 includes a noise reduction filter in record path and the characteristic can be controlled via the TM_WIN_MD (1x53), MEDIAN_MD, TM_SLOP, and TM_THR (1x50) register. But this noise reduction filter is only available for normal record mode.

The TM_WIN_MD register defines window type to reduce spot noise as “0” for 3X3 matrix, “1” for cross matrix, “2” for multiplier matrix, and “3” for vertical bar matrix. The MEDIAN_MD defines the noise reduction filter mode as “0” for adaptive threshold median filter mode, “1” for normal median filter mode. For adaptive threshold median filter mode, the TW2835 has cross-correlation detector for noise detection. If cross-correlation value is over than TM_THR of noise threshold level, the noise reduction filter will be operated according to the graph defined by the TM_SLOP register.

The following Fig 43 shows the slope control for adaptive threshold median filter mode.

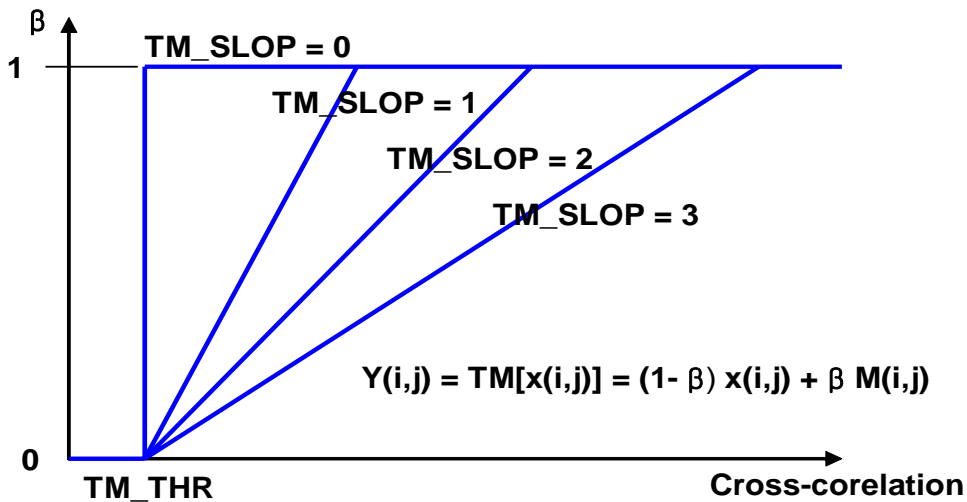

Fig 43 The slope control for adaptive threshold median filter mode

The TW2835 supports the noise reduction filter for each channel via the NR_EN (1x60, 1x63, 1x66, and 1x69) register. The TW2835 also supports auto noise reduction filter mode via the AUTO_NR_EN (1x55) register that is enabled when night is detected. Additionally the TW2835 has programmable black level of luminance component in record path to reduce the black spot noise via the LIM_656_Y (0xC1, and 0xC2) register.

Channel ID Encoder

The TW2835 supports the channel ID encoding to detect the picture information in video stream for record path. The TW2835 has three kinds of channel ID such as User channel ID, Detection channel ID and Auto channel ID. The User channel ID is used for customized information such as system information and date. The Detection channel ID is used for detected information of current live input such as motion, video loss, blind and night detection. The Auto channel ID is employed for automatic identification of picture configuration such as video input path number with cascaded stage, analog switch, event, region enable, and field/frame mode information. The TW2835 also supports both analog and digital type channel ID during VBI period.

Channel ID Information

The channel ID can be composed of 8 byte User channel ID, 8 byte Detection channel ID and 4 byte Auto channel ID. The User channel ID is defined by user and may be used for system information, date and so on. The Detection channel ID is used for the detected information such as video loss state, motion, blind and night detection. The Auto channel ID is used to identify the current picture configuration. Basically the Auto channel ID has 4 byte data that contains 4 region channel information in one picture such as QUAD split image. That is, each region has 1 byte channel information. The Auto channel ID format is described in the following Table 4.

Table 4. The Auto channel ID information

Bit	Name	Function
7	REG_EN	Region Enable Information
6	EVENT	New Event Information
5	FLDMODE	Sequence Unit (0 : Frame, 1 : Field)
4	ANAPATH	Analog switch information
[3:2]	CASCADE	Cascaded Stage Information
[1:0]	VIN_PATH	Video Input Path Number (depending on DEC_PATH_Y)

The REG_EN is used to indicate whether the corresponding 1/4 region is active or blank. The EVENT is used to denote the updating information of each channel in live, strobe or switch operation. Especially the EVENT information is very useful for switch operation or non-realtime application such as pseudo 8ch or dual page mode because each channel can be updated whenever EVENT is detected. The FLDMODE is used to denote the sequence unit such as frame or field. The ANAPATH is used to identify the analog switch information in the channel input path. The ANAPATH information is required for non-realtime application such as pseudo 8ch, dual page or pseudo 8channel MUX application using analog switch. The CASCADE is used to indicate the cascaded stage of channel in chip-to-chip cascaded application. The VIN_PATH information is used to indicate the video input path of channel.

Four bytes of Auto channel ID can be distinguished by its order. The first byte of Auto channel ID defines the left top region channel. Likewise the second byte defines the right top, the third byte defines the left bottom and the fourth byte defines the right bottom region channel in one

picture. The following Fig 44 shows the example of Auto channel ID for various recording output formats.

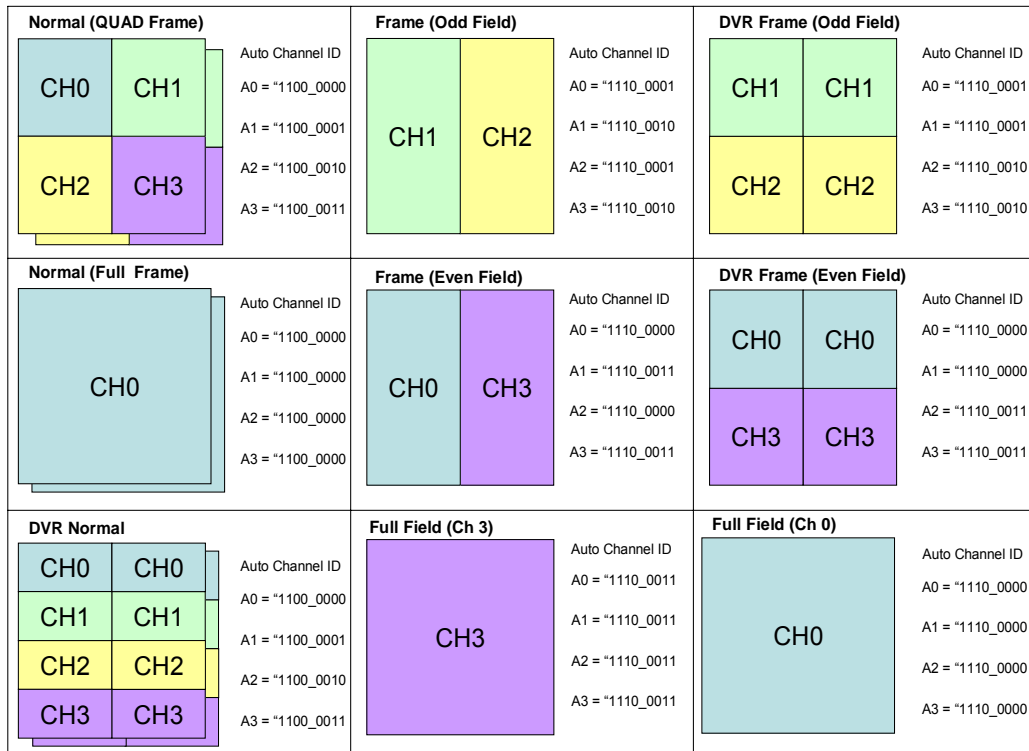

Fig 44 The example of auto channel ID for various record output formats

The Detection channel ID consists of 2 bytes because each channel requires 4 bits for video loss, motion, blind and night detection information. The detailed Detection channel ID format is described in the following Table 5.

Table 5. The Detection channel ID information

Bit	Name	Function
3	NOVID	Video loss Information (0 : Video is Enabled, 1 : Video loss)
2	MD_DET	Motion Information (0 : No Motion, 1 : Motion)
1	BLIND_DET	Blind Information (0 : No Blind, 1 : Blind)
0	NIGHT_DET	Night Information (0 : Day, 1 : Night)

In analog channel ID type, 4 byte information can be inserted in one line so that only the half line is required for 1 chip detection channel ID, but two lines are always reserved for detection channel ID in case of cascaded application. For cascaded application, max 8 bytes are needed for detection channel ID information. The order of those channel ID depends on the cascaded stage via the LINK_NUM (1x00) register. That is, the master chip information (LINK_NUM = "0") is output at first order and the last slave chip information (LINK_NUM = "3") at last. The TW2835 also supports non-realtime detection channel ID format via the VIS_DM_MD (1x83) register. The non-realtime detection channel ID requires 4 bytes for 8 channel information. So one line is used for it and the order is that VIN_A information (ANA_SW = "0") is output at first and VIN_B information at last.

Analog Type Channel ID in VBI

The TW2835 supports the analog type channel ID during VBI period. The analog channel ID can include an Auto channel ID, Detection channel ID and User channel ID. Each channel ID can be enabled via the VIS_AUTO_EN, AUTO_RPT_EN, VIS_DET_EN, VIS_USER_EN (1x80) registers. The Auto channel ID requires one line basically, but can need one more line for repetition. Both Detection channel ID and User channel ID require two lines so that total six lines are used for analog type channel ID.

The vertical starting position of analog channel ID is controlled by the VIS_LINE_OS (1x83) register with 1 line unit and the horizontal starting position is defined via VIS_PIXEL_HOS(1x81) register with 2 pixel unit. The pixel width of each bit is controlled by the VIS_PIXEL_WIDTH (1x82) register and the magnitude of each bit is defined by the VIS_HIGH_VAL/VIS_LOW_VAL (1x84/1x85) register.

The analog channel ID consists of run-in clock, channel ID data, type and parity bit. The run-in clock insertion is enabled via the VIS_RIC_EN (1x80) register. The channel ID data can include 4 byte information and the channel ID type contains 3 bits that “0” is meant for Auto channel ID, “1” for repeated channel ID, “2” for Detection channel ID of master and first slave stage chip, “3” for Detection channel ID of second and third slave chip, “4” for User channel ID of VIS_MAN0~3, and “5” for User channel ID of VIS_MAN4~8. The parity is 1 bit width and used for even parity. The analog channel ID is located right after digital channel ID line. The following Fig 45 shows the illustration of analog channel ID.

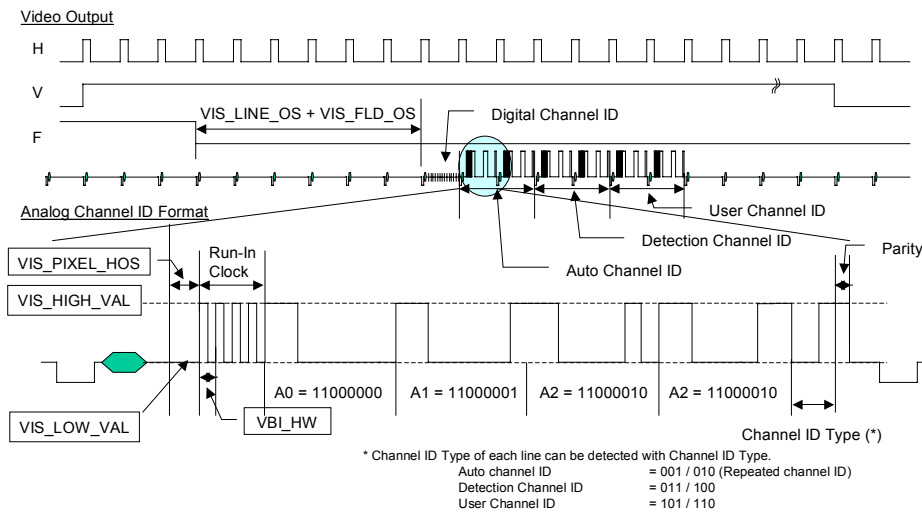

Fig 45 The illustration of analog channel ID

Digital Type Channel ID in VBI

The TW2835 also provides the digital type channel ID during VBI period. It's useful for DSP application because the channel ID can be inserted in just 1 line with special format. The digital channel ID is located before analog channel ID line. The digital channel ID can be enabled via the VIS_CODE_EN (1x80) register.

The digital channel ID is inserted in Y data in ITU-R BT.656 stream and composed of ID # and channel information. The ID # indicates the index of digital type channel ID including the Start code, Auto/Detection/User channel ID and End code. The ID # has 0 ~ 63 index and each channel information of 1 byte is divided into 2 bytes of 4 LSB that takes "50h" offset against ID # for discrimination. The Start code is located in ID# 0 ~ 1 and the Auto channel ID is situated in ID# 2 ~ 9. The Detection channel ID is located in ID # 10 ~ 25 and the User channel ID is situated in ID # 26 ~ 41. The End code occupies the others. The digital channel ID is repeated more than 5 times during horizontal active period. The following Fig 46 shows the illustration of the digital channel ID.

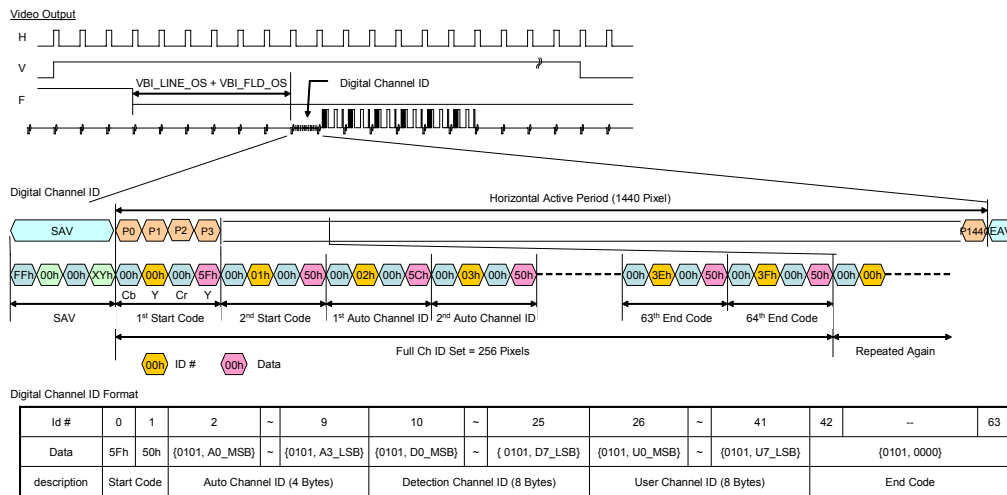

Fig 46 The illustration of the digital channel ID in VBI period

Digital Type Channel ID in Channel Boundary

The TW2835 also supports the extra type of digital channel ID in horizontal boundary of each channel. This information can be used for very easy memory management of each channel in DSP solution because this digital channel ID information includes not only the channel information but also line number of picture. The Auto channel ID format is described in the following Table 6.

Table 6 The digital channel ID information in active area

Bit	Name	Function
[15:7]	LINENUM	Active Line number
6	FIELD	Field Polarity Information
5	REG_EN	Region Enable Information
4	ANAPATH	Analog switch information
[3:2]	CASCADE	Cascade Stage Information
[1:0]	VIN_PATH	Video Input Path Number (depending on DEC_PATH_Y)

This digital channel ID is enabled in the horizontal active area by setting “1” to the CH_START (1x55) register. The following Fig 47 shows the digital channel ID in channel boundary.

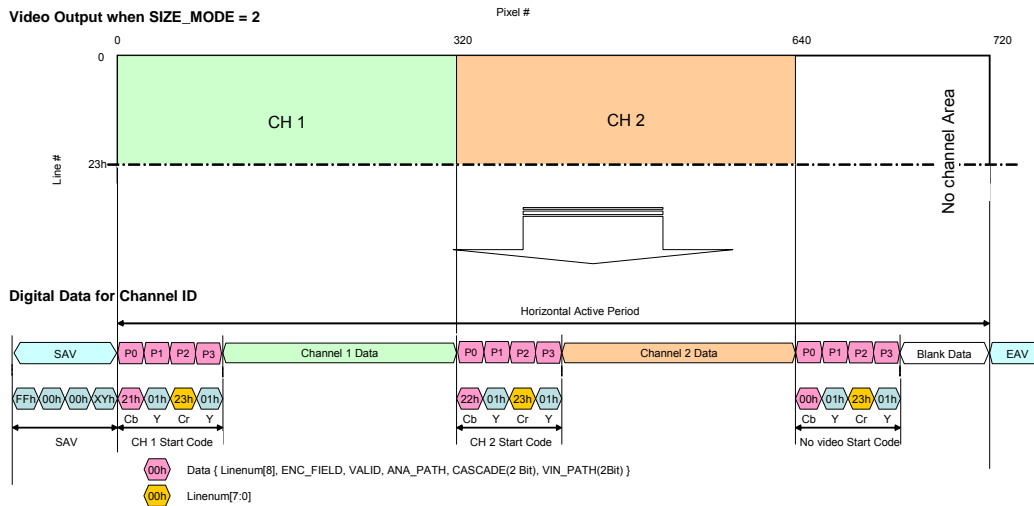

Fig 47 The digital channel ID format in channel boundary

Chip-to-Chip Cascade Operation

The TW2835 supports chip-to-chip cascade connection up to 4 chips for 16-channel application and also provides the independent operation for display and record path. That is, the display path can be operated with cascade connection even though the record path is working in normal operation. Likewise, the cascade connection of record path is limited within 4 chips while the infinite cascade connection of display path can be supported for more than 16-channel application.

In cascade operation, the TW2835 transfers all information of slaver chips to master chip including video data, zoom factors, switching information and 2D box except overlay information such as single box, mouse pointer and bitmap information. Therefore, the master chip should be controlled for overlay and the lowest slaver chip should be controlled for the others such as video data, zoom control and switching queue.

Channel Priority Control

When 2 channels are overlapped in chip-to-chip cascade operation for display path, there is a priority with the following order such as popup attributed channel of master device, popup attributed channel of slaver device, non-popup attributed channel of master device and non-popup attributed channel of slaver device. Using this popup attribute, the TW2835 can implement the channel overlay such as PIP, POP, and full D1 format channel switching in chip-to-chip cascade connection.

For QUAD multiplexing record output in chip-to-chip cascade application, the popup priority of the channel is controlled via the QUAD_MUX queue. The QUAD_MUX operation is enabled via the POS_CTL_EN (1x70) register and the operation mode should be set into strobe operation (FUNC_MODE = "1"). If the POS_CTL_EN is "0", the channel position is defined via the PIC_POS (1x6D) register and the priority from top to bottom layer is controlled by the popup attribute like the display path. If the POS_CTL_EN is "1", the channel position and priority is controlled by the pre-defined queue or interrupt.

The TW2835 supports the interrupt triggering via the POS_INTR (1x70), POS_CH (1x73, 1x74) register and also provides the internal or external triggering mode for the QUAD_MUX operation. The triggering mode is selected via the POS_TRIG_MODE (1x70) register such as "0" for external trigger mode and "1" for internal trigger mode.

The QUAD_MUX queue size can be defined by the POS_QUE_SIZE (1x71) register. To change the channel popup sequence in internal queue, the POS_QUE_WR (1x75) register should be set to "1" after defining the queue address with the POS_QUE_ADDR (1x75) register and the channel number with the POS_CH (1x73, 1x74) register. The POS_QUE_WR register will be cleared automatically after updating queue. The QUAD_MUX queue is shared with the normal switching queue so that the maximum queue size for QUAD_MUX is 32 (=128/4) depth.

The QUAD_MUX switching period can be defined via the POS_QUE_PERIOD (1x72) register that has 1 ~ 1024 period range in the internal triggering mode. The switching period unit is controlled via the POS_FLD_MD (1x71) register as field or frame. If switching period unit is frame, switching will occur at the beginning of odd field. The internal field counter can be reset at anytime using the POS_CNT_RST (1x75) register that will be cleared automatically after set to "1". To reset an internal queue position, the POS_QUE_RST (1x75) register should be set to "1" and will be cleared automatically after set to "1". The structure of QUAD_MUX switching operation is shown in the following Fig 48.

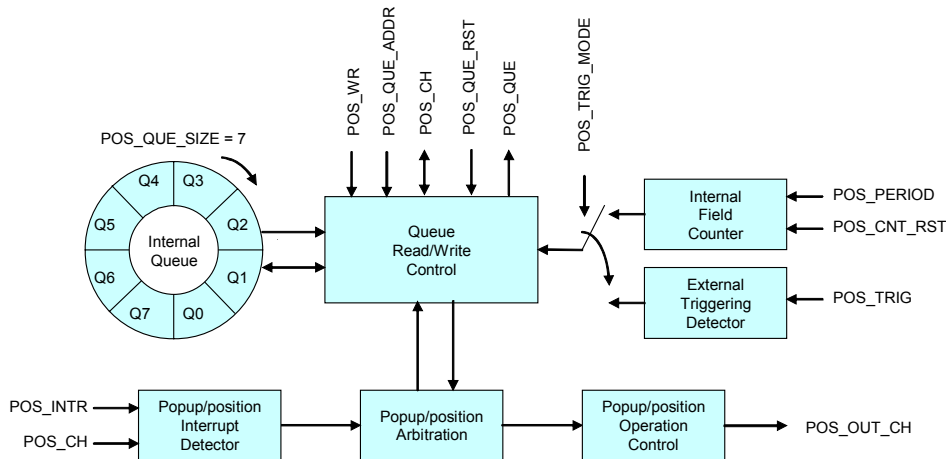

Fig 48 The structure of QUAD_MUX switching operation when POS_SIZE = 7

For QUAD_MUX switching operation by field unit, the TW2835 supports an auto strobe mode for channel to be updated automatically with specific field data. The STRB_FLD (1x04, 1x54) register is used to select specific field data in strobe mode and the STRB_AUTO (1x07, 1x57) register is used to update it automatically.

The QUAD_MUX operation has several limitations. The first is that the channel region should not be overlapped with other channel region via the PIC_SIZE and PIC_POS register. The second is that the channel position and popup property in live or strobe operation mode can be controlled by the popup/position control. But the channel position and priority in switch operation mode is determined by the QUAD_MUX queue. The third is that the POS_CH register in QUAD_MUX queue should be set as the following sequence that is the left top, right top, left bottom and right bottom position in the picture. The POS_CH register includes the cascade stage and channel number information.

120 CIF/Sec Record Mode

For chip-to-chip cascade connection, the DLINKI, VLINKI and HLINKI pin in master chip should be connected to VDOUTX, VSENC and HSENC pin in slaver chips. So the VDOUTX, VSENC and HSENC output pin is only available in master device when cascaded.

The TW2835 has several registers for cascade operation such as the LINK_EN, LINK_NUM, LINK_LAST (1x00) and SYNC_DEL (1x7E) register. For lowest slaver chip, both LINK_LAST_X and LINK_LAST_Y should be set to "1". To receive the cascade data from slaver chip, either LINK_EN_X or LINK_EN_Y should be set to "1". To transfer the cascade data properly among the chips, the LINK_NUM and SYNC_DEL should be set properly in accordance with its order. The information of switching channel can be taken from master chip via the channel ID in video stream output or by reading the MUX_OUT_CH (1x08, 1x6E) register. The information of switching channel can also be taken from the lowest slaver chip via the MPP1/2 pins. The following Fig 49 illustrates the cascade connection for 120 CIF/Sec record mode.

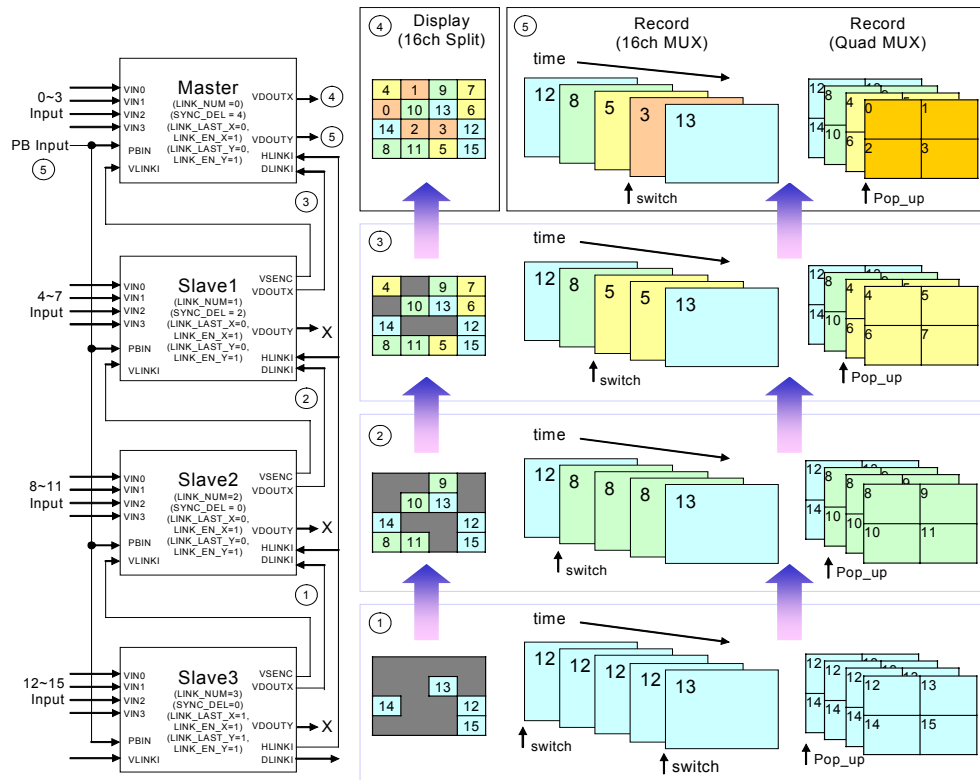

Fig 49 The cascade connection for 120 CIF/sec record mode

240 CIF/Sec Record Mode

The TW2835 supports 240 CIF/Sec record mode in chip-to-chip cascade connection. In this case, the display path is composed of 4 chip cascade stage, but the record path consists of 2 chip cascade stage. That is, two lowest slaver chips for record path should be set with the LINK_LAST_Y = "1" and the switching channel information can be taken from two master chips for record path via the channel ID in video stream or by reading the MUX_OUT_CH (1x6E) register. The following Fig 50 illustrates the cascade connection for 240 CIF/Sec record mode.

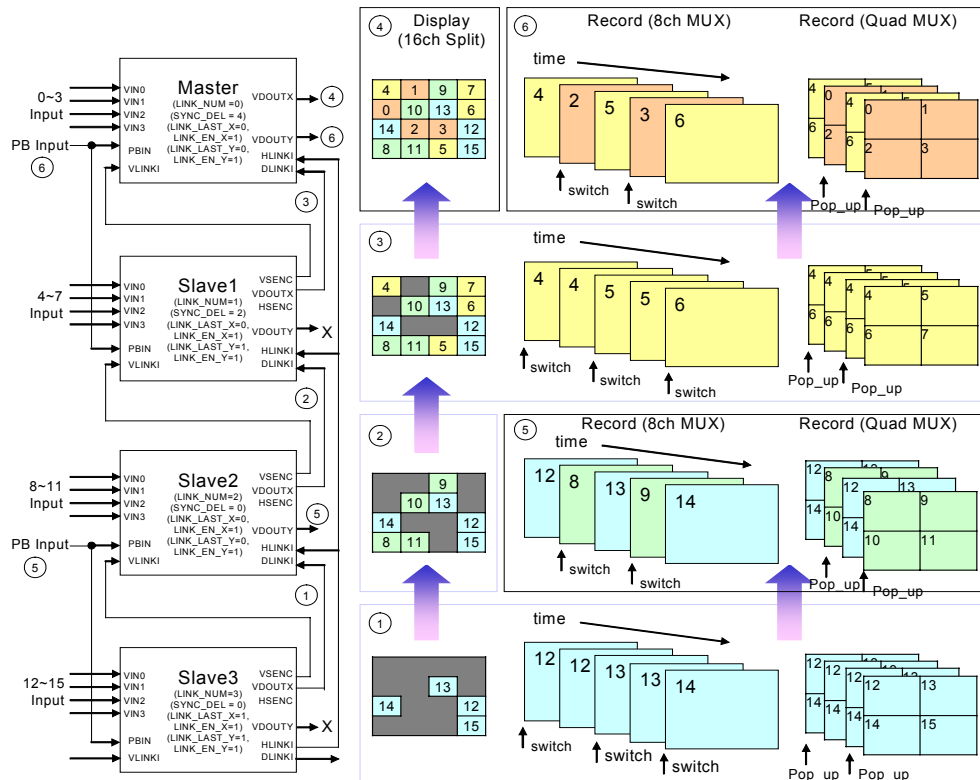

Fig 50 The cascade connection for 240 CIF/sec record mode

480 CIF/Sec Record Mode

The TW2835 also supports 480 CIF/Sec record mode in chip-to-chip cascade connection. In this case, the display path is composed of 4 chip cascade stage, but the record path has no cascade connection. Even though the record path has no cascade connection, the LINK_NUM should be set properly in accordance with its cascade order for correct channel number in channel ID and the LINK_EN_Y should be set to "0" or the LINK_LAST_Y should be set to "1". The TW2835 transfers the slaver chip information to master chip such as zoom control and 2D box only for display path and the switching channel information for record path can be taken from each chip via the channel ID in video stream or by reading the MUX_OUT_CH (1x6E) register. The following Fig 51 illustrates the cascade connection for 480 CIF/Sec record mode.

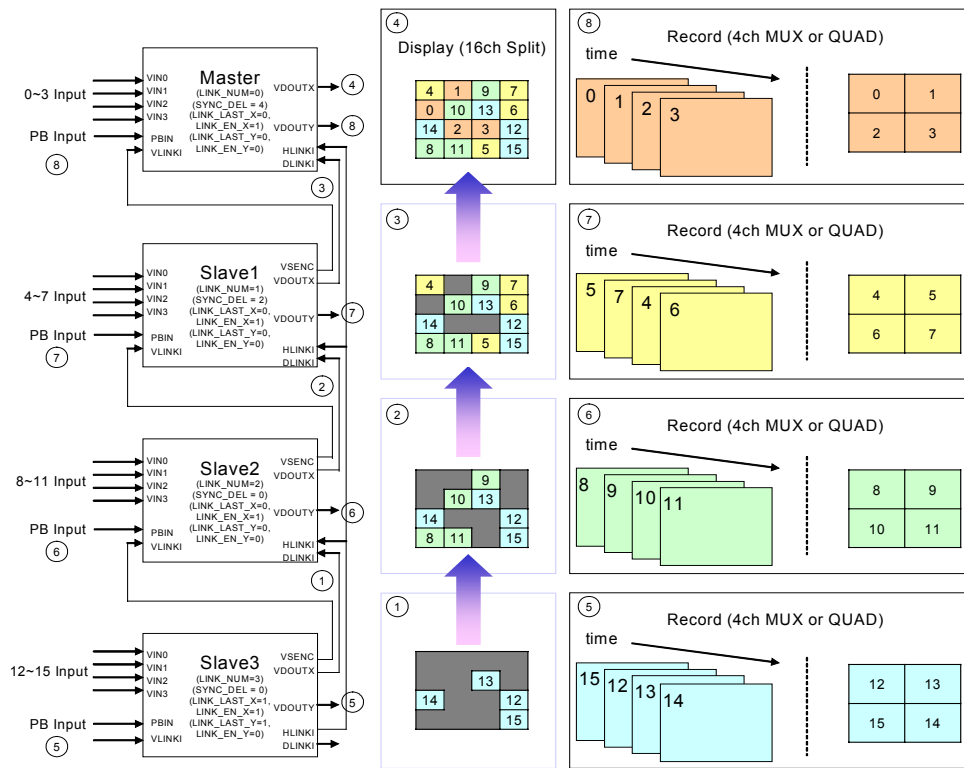

Fig 51 The cascade connection for 480 CIF/Sec record mode

Infinite Cascade Mode for Display Path

In normal cascade connection, the master chip has LINK_NUM = "0" and the lowest slaver chip has LINK_NUM = "3". The master chip can output both display and record path, but the slaver device can output only record path. To implement more than 16 channel application, the TW2835 also provides the infinity cascade connection for display path. That is, the video data and popup information can be transferred to next cascade chip even though the master chip is set with LINK_NUM = "0" and the slaver chip with LINK_NUM = "3" for display path. This mode can be enabled via the T_CASCADE_EN (1x7F) register.

The following Fig 52 illustrates the multiple cascade connection for display path. In this example, the display path in the last master chip can output 32 channel video and the record path can implement "480 CIF/sec" with lower 4 chips and "120 CIF/sec" with upper 4 chips.

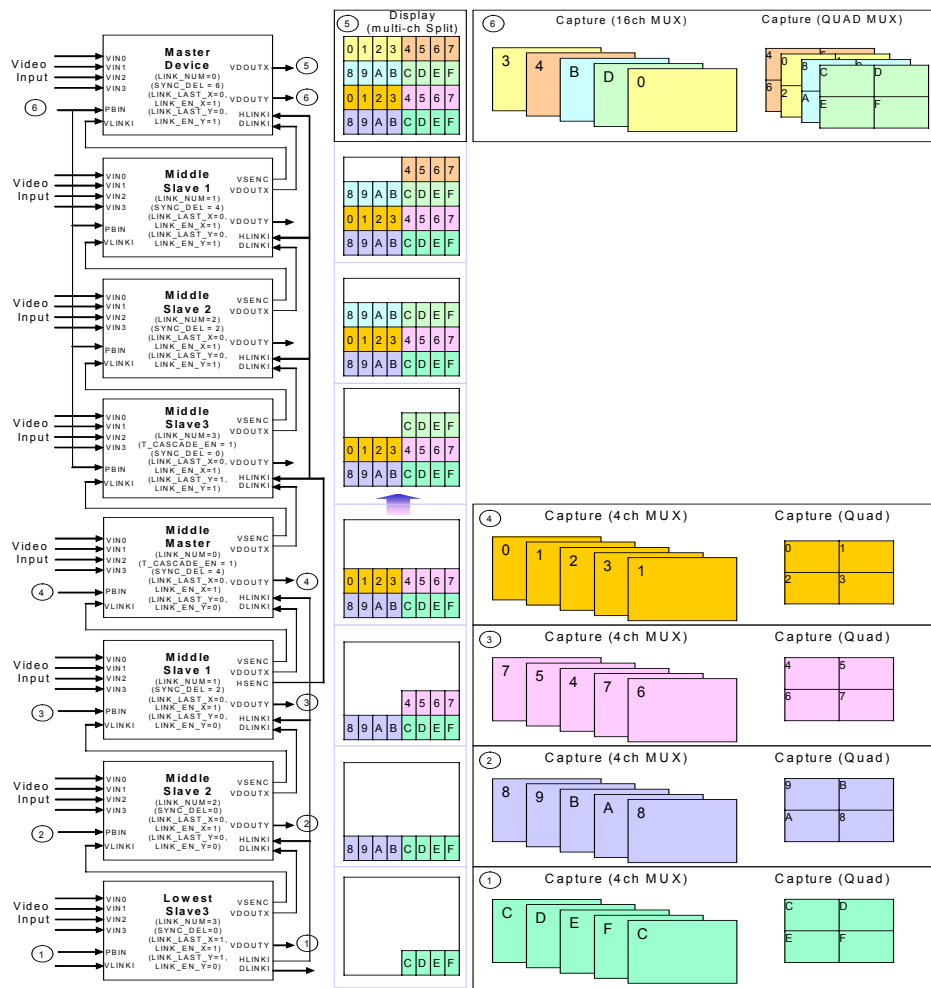

Fig 52 Infinite cascade mode for display path

OSD (On Screen Display) Control

The TW2835 provides various overlay layers such as 2D box layer, bitmap layer, single box layer and mouse pointer layer that can be overlaid on display and record path independently. The following Fig 53 shows the overlay block diagram.

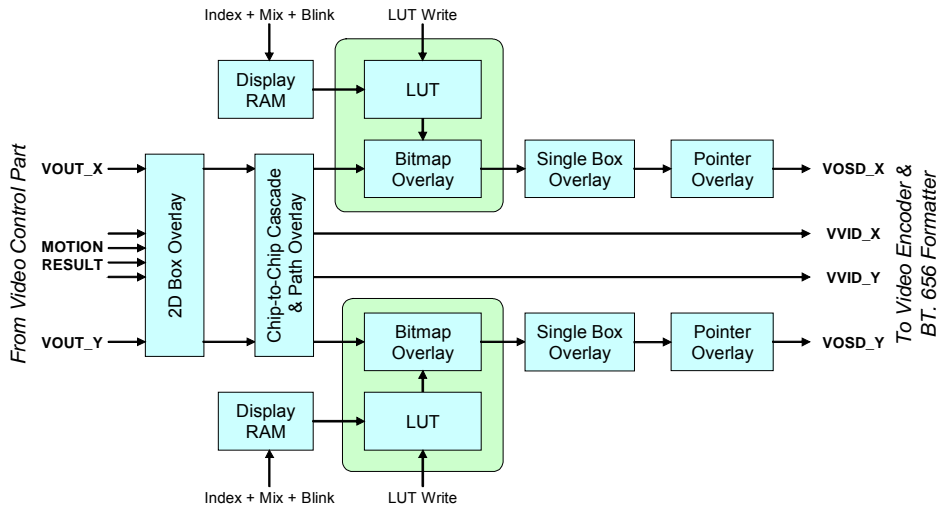

Fig 53 Overlay block diagram

The bitmap data can be downloaded from host and supported up to 2 fields * 6 pages for display path and 2 field * 1 page for record path. The TW2835 supports four single and 2D arrayed boxes that are programmable for size, position and color.

Dual analog video outputs and dual digital video outputs can enable or disable a bitmap, single box and mouse pointer overlay respectively. The overlay priority of OSD is shown in Fig 54. The various OSD overlay function is very useful to build GUI interface.

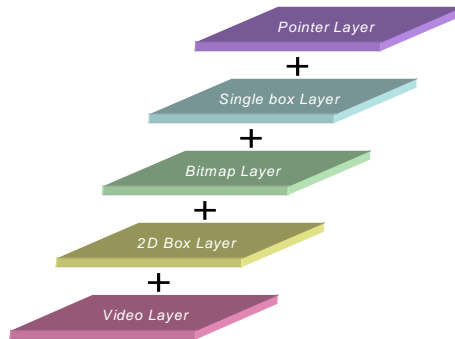

Fig 54 The overlay priority of OSD layer

2 Dimensional Arrayed Box

The TW2835 supports four 2D arrayed boxes that have programmable cell size up to 16x16. The 2D arrayed box can be used to make table menu or display motion detection information via the 2DBOX_MODE (2x60, 2x68, 2x70, 2x78) register. The 2D arrayed box is displayed on each path by the 2DBOX_EN (2x60, 2x68, 2x70, and 2x78) register.

For each 2D arrayed box, the number of row and column cells is defined via the 2DBOX_HNUM and 2DBOX_VNUM (2x66, 2x6E, 2x76, and 2x7E) registers. The horizontal and vertical location of left top is controlled by the 2DBOX_HL (2x62, 2x6A, 2x72, and 2x7A) register and the 2DBOX_VT (2x64, 2x6C, 2x74, and 2x7C) registers. The horizontal and vertical size of each cell is defined by the 2DBOX_VW (2x65, 2x6D, 2x75, and 2x7D) registers and the 2DBOX_HW (2x63, 2x6B, 2x73, and 2x7B) registers. So the whole size of 2D arrayed box is same as the sum of cells in row and column.

The boundary of 2D arrayed box is enabled by the 2DBOX_BNDEN (2x61, 2x69, 2x71, and 2x79) register and its color is controlled via the 2DBOX_BNDCOL (2x5F) register which selects one of 4 colors such as 0% black, 25% gray, 50% gray and 75% white.

Especially the TW2835 provides the function to indicate cursor cell inside 2D arrayed box. The cursor cell is enabled by the 2DBOX_CUREN (2x60, 2x68, 2x70, and 2x78) register and the displayed location is defined by the 2DBOX_CURHP and 2DBOX_CURVP (2x67, 2x6F, 2x77, and 2x7F) registers. Its color is a reverse color of cell boundary. It is useful function to control motion mask region.

The plane of 2D arrayed box is separated into mask plane and detection plane. The mask plane represents the cell defined by MD_MASK (2x86 ~ 2x9D, 2xA6 ~ 2xBD, 2xC6 ~ 2xDD, 2xE6 ~ 2xFD) register. The detection plane represents the motion detected cell excluding the mask cells among whole cells. The mask plane of 2D arrayed box is enabled by the 2DBOX_MSKEN (2x60, 2x68, 2x70, 2x78) register and the detection plane is enabled by the 2DBOX_DETEN (2x60, 2x68, 2x70, 2x78) register. The color of mask plane is controlled by the MASK_COL (2x5B ~ 2x5E) register and the color of detection plane is defined by the DET_COL (2x5B ~ 2x5E) register which selects one out of 12 fixed colors or 4 user defined colors using the CLUT (2x13 ~ 2x1E) register. The mask plane of 2D arrayed box shows the mask information according to the MD_MASK registers automatically and the additional narrow boundary of each cell is provided to display motion detection via the 2DBOX_DETEN register and its color is a reverse cell boundary color. The plane can be mixed with video data by the 2DBOX_MIX (2x60, 2x68, 2x70, 2x78) register and the alpha blending level is controlled as 25%, 50%, and 75% via the ALPHA_2DBOX (2x1F) register. Even in the horizontal / vertical mirroring mode, the video data and motion detection result can be matched via the 2DBOX_HINV and 2DBOX_VINV (2x81, 2xA1, 2xC1, 2xE1) registers.

The TW2835 has 4 2D arrayed boxes so that 4 video channels can have its own 2D arrayed box for motion display mode. To overlay mask information and motion result on video data properly, the scaling ratio of video should be matched with 2D arrayed box size.

The following Fig 55 shows the 2D arrayed box of table mode and motion display mode.

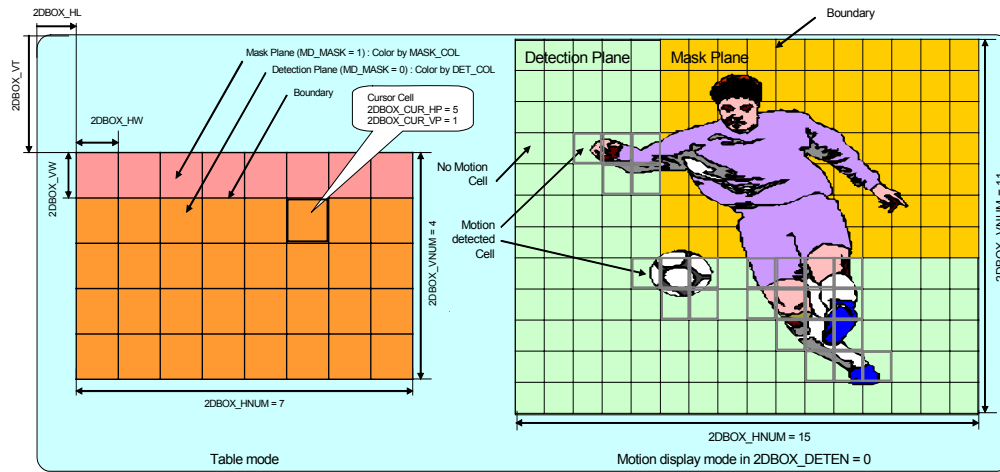

Fig 55 The 2D arrayed box in table mode and motion display mode

In case those several 2D arrayed boxes have same region, there will be a conflict of what to display for that region. Generally the TW2835 defines that 2D arrayed box 0 has priority over other 2D arrayed box. So if a conflict happens between more than 2 2D arrayed boxes, 2D arrayed box 0 will be displayed first as top layer and 2D arrayed box 1, box 2, and box 3 are hidden beneath that are not supported for pop-up attribute like channel attribute.

Bitmap Overlay

The TW2835 has bitmap overlay function for display and record path independently. Each bitmap overlay function block consists of display RAM, lookup table (LUT) and overlay control block. The display RAM stores the downloaded bitmap data from host via the OSD_BUF_DATA (2x00 ~ 2x03) registers by 4 dot unit for display path and 8 dot unit for record path. Actually, the downloaded bit map data consists of index and attributes such as mix and blink. The TW2835 can support max 6 frame bit map pages for display path, and 1 frame for record path. But to extend the bit map page to 1 ~ 5 frame page, the save function is not allowed because those frame pages are overlapped with save function page.

The TW2835 has the respective display RAM for display and record path and supports full bitmap overlay with 720 x 576/480 dot resolution for both paths. Each dot has its own attributes such as mix, blink, and LUT index (6 bits for display path and 2 bits for record path). The mix attribute makes character mixed with video data and blink attribute gets character to be blinked with the period defined by the BLK_TIME (2x1F) register. The index attribute selects the displayed color out of 64 colors in display path and 4 colors in record path. If the index is 0xFFh for display path and 0xFh for record path, the dot is disabled and cannot be displayed on the picture. The lookup table (LUT) converts the index into the real displayed color (Y/Cb/Cr). The relationship between the OSD_BUF_DATA and the displayed location is shown in the following Fig 56.

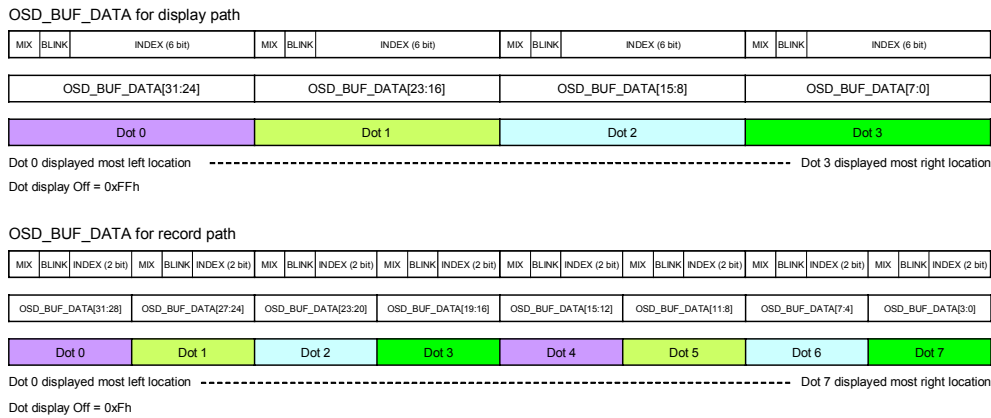

Fig 56 The relationship between the OSD_BUF_DATA and the displayed location

The following Fig 57 shows the structure of the display RAM in display and record path.

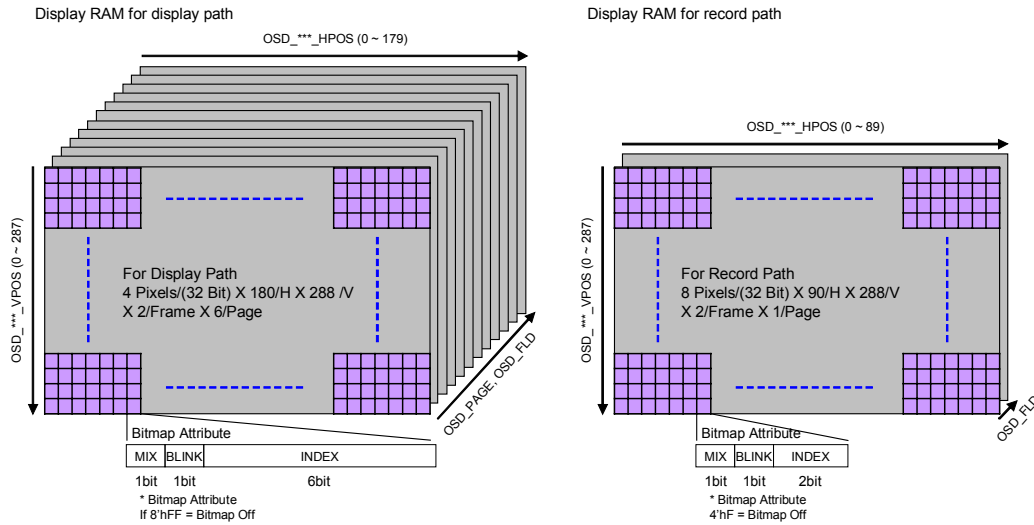

Fig 57 The structure of the display RAM

The TW2835 support two method for downloading in display RAM such as using internal buffer and using graphic acceleration via the OSD_ACC_EN (2x0A) register. The internal buffer usage is normal method to download a bit map data by 4 ~ 64 dot for display path and 8 ~ 128 dot for record path through the OSD_BUF_DATA, OSD_BUF_ADDR and OSD_BUF_WR (2x04) register. The horizontal starting position for downloading bitmap in display RAM is defined by the OSD_START_HPOS (2x05) register with 4 dot unit for display path and 8 dot unit for record path. The vertical starting position for downloading bitmap is defined by the OSD_START_VPOS (2x07, 2x09) register with 1 line unit. The MSB of the OSD_START_VPOS selects the field of downloading as “0” is for odd field and “1” is for even field. The writing data size of internal buffer is defined by the OSD_BL_SIZE (2x0A) register and the writing path of internal buffer is selected by the OSD_MEM_PATH (2x0A) register (“0” for display path and “1” for record path). The download processing is started by the OSD_MEM_WR (2x0A) register that will be cleared automatically when downloading is finished.

The graphic acceleration is useful for single writing, box, line drawing and clearing bitmap data because it will automatically fill in specific display RAM area via the OSD_BUF_DATA. For the graphic acceleration, the OSD_START_HPOS, OSD_START_VPOS, OSD_MEM_PATH and OSD_MEM_WR registers except the OSD_BL_SIZE register are shared with internal buffer. Additionally the horizontal and vertical ending positions are defined by the OSD_END_HPOS (2x06) and OSD_END_VPOS (2x08) register. For proper graphic acceleration, the graphic acceleration region may be separated into multiple regions like 16 x A + B. That is, the “A” region can be divided by 16 unit (1unit is 8 dot for display path, 4 dot for record path) and the

remained region can be less than 16 unit. So if the region can not be divided by 16 unit, the graphic acceleration should be performed two times independently. The graphic acceleration is started by the OSD_MEM_WR (2x0A) register that will be cleared automatically when graphic acceleration is finished.

The Fig 58 shows the flowchart for downloading data to display RAM and lookup table.

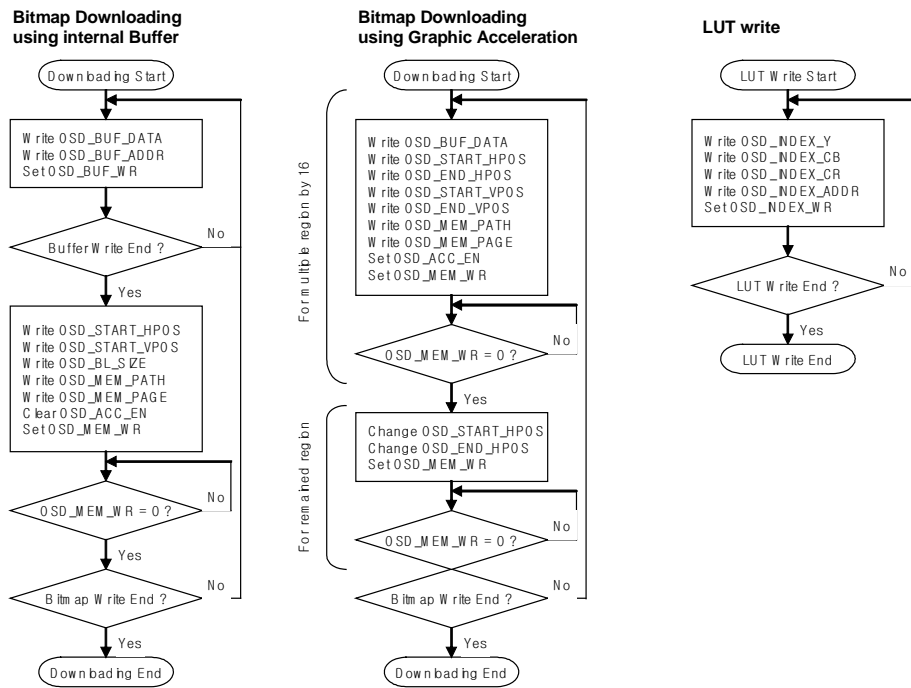

Fig 58 The flowchart for downloading data to display RAM

The field of bitmap is selected by the OSD_FLD (2x0F) register for display and record path. For OSD_FLD = “1” or “2”, only one field data is displayed for both fields, but for OSD_FLD = “3”, frame data is displayed so that the bitmap resolution can be enhanced 2 times in vertical direction. For display path, the TW2835 can read the bitmap data from the extended page of display RAM via the OSD_RD_PAGE (2x0F) register. It’s useful to change bitmap data from pre-downloaded bitmap page.

The blink period is controlled via the TBLINK_OSD (2x1F) register as “0” for 0.25 sec, “1” for 0.5 sec, “2” for 1 sec, and “3” for 2 sec period. The alpha blending level is also controlled via ALPHA_OSD (2x1F) register as 25%, 50%, and 75%.

The TW2835 supports dual color LUT (Look-Up Table) with Y/Cb/Cr color space for display and record path via the OSD_INDEX_Y (2x0B), OSD_INDEX_CB (2x0C) and OSD_INDEX_CR (2x0D) register. The OSD_INDEX_ADDR (2x0E) register controls the writing position of LUT as

“0 ~ 63” is for LUT of display path and “64 ~ 67” for record path. The update processing of color LUT is started by the OSD_INDEX_WR (2x0E) register that will be cleared automatically when downloading is finished.

The TW2835 also provides bitmap overlay function between display and record path via the OSD_OVL_MD (2x38) register as “0” for no overlay, “1” for low priority overlay, “2” for high priority overlay, and “3” for only the other path overlay. The following Fig 59 shows the bitmap overlay function between display and record path.

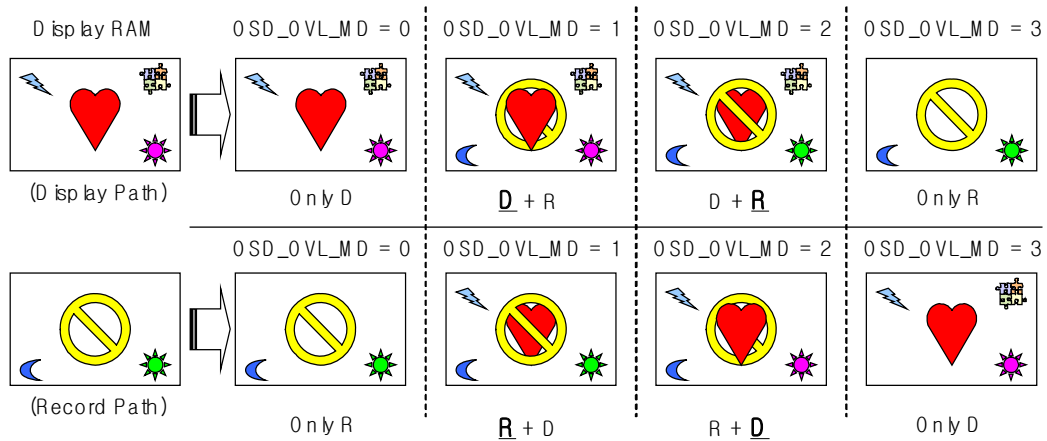

Fig 59 The bitmap overlay function between display and record path

Single Box

The TW2835 provides 4 single boxes that can be used for picture masking or box cursor. Each single box has programmable location and size parameters with the BOX_HL (2x22, 2x28, 2x2D, 2x34), BOX_HW (2x23, 2x29, 2x2E, 2x35), BOX_VT (2x24, 2x2A, 2x2F, 2x36) and BOX_VW (2x25, 2x2B, 2x30, 2x37) registers. The BOX_HL is the horizontal location of box with 2 pixel unit and the BOX_HW is the horizontal size of box with 2 pixel unit. The BOX_VT is the vertical location of box with 1 line unit and the BOX_VW is the vertical size of box with 1 line unit.

The BOX_PLNEN (2x20, 2x26, 2x2B, 2x32) register enables each plane color and its color is defined by the BOX_PLNCOL (2x21, 2x27, 2x2C, 2x33) register, which selects one out of 12 fixed colors or 4 user defined colors using the CLUT (2x13 ~ 2x1E) register. Each box plane can be mixed with video data via the BOX_PLNMIX (2x20, 2x26, 2x2B, 2x32) register and the alpha blending level is controlled via the ALPHA_BOX (2x1F) register.

The color of box boundary is enabled via the BOX_BNDEN (2x20, 2x26, 2x2B, 2x32) register and its color is defined by the BOX_BNDCOL (2x20, 2x26, 2x2B, 2x32) registers.

In case that several boxes have same region, there will be a conflict of what to display for that region. Generally the TW2835 defines that box 0 has priority over box 3. So if a conflict happens between more than 2 boxes, box 0 will be displayed first as top layer and box 1 to box 3 are hidden beneath that are not supported for pop-up attribute unlike channel display.

Mouse Pointer

The TW2835 supports the mouse pointer that has attributes such as pointer enabling, pointer location, blink and sub-layer enabling. The mouse pointer can be overlaid on both display and record path independently.

The mouse pointer is located in the full screen according to the CUR_HP (2x11) register with 2 pixel step and CUR_VP (2x12) register with 1 line step. Two kinds of mouse pointer are provided through the CUR_TYPE (2x10) register. The CUR_SUB (2x10) register determines a pointer inside area to be filled with 100% white or to be transparent and the CUR_BLINK (2x10) register controls a blink function of mouse. Actually the CUR_ON (2x10) register enables or disables the mouse pointer for display and record path independently.

Video Output

The TW2835 supports dual digital video outputs with ITU-R BT.656 format and 2 analog video outputs with built-in video encoder at the same time. Dual video controllers generate 4 kinds of video data such as the display path video data with/without OSD and the record path video data with/without the OSD. The CCIR_IN (1xA0) register selects one of 4 video data for the digital video output and ENC_IN (1xA0) register selects one of 4 video data for the analog video output as shown in Fig 60.

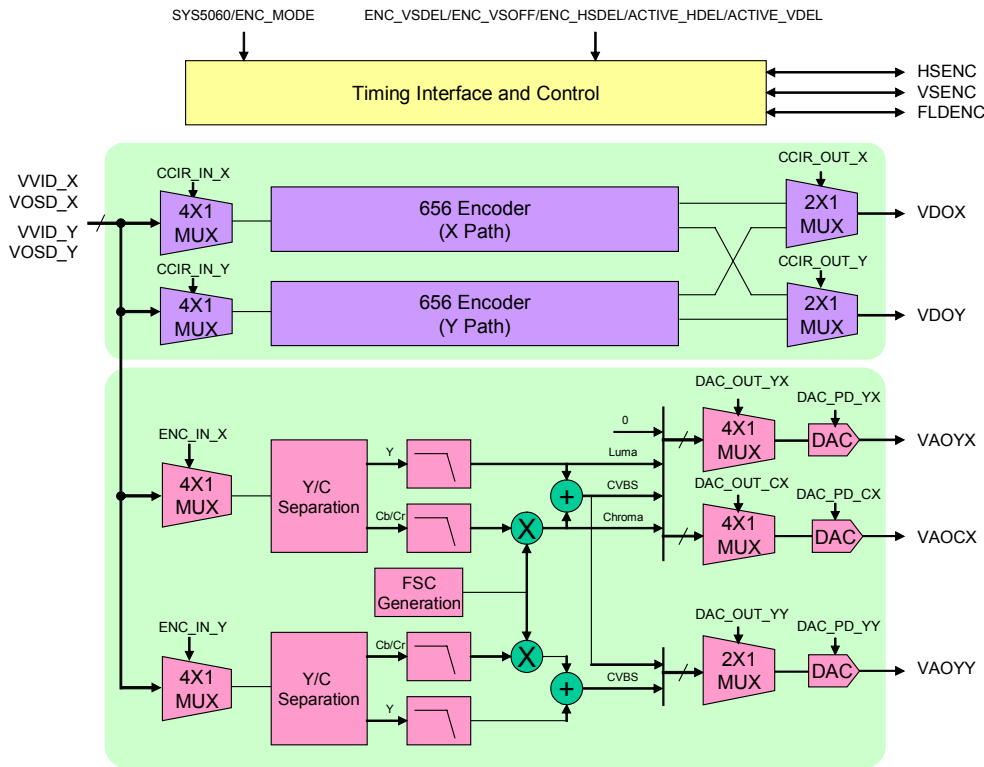

Fig 60 Video output selection

The TW2835 supports all NTSC and PAL standards for analog output, which can be composite video, or S-video video for both display and record path. All outputs can be operated as master mode to generate timing signal internally or slave mode to be synchronized with external timing.

Timing Interface and Control

The TW2835 can be operated in master or slave mode via the ENC_MODE (1xA4) register. In master mode, the TW2835 can generate all of timing signals internally while the TW2835 receives all of timing signals from external device in slaver mode. The polarity of horizontal, vertical sync and field flag can be controlled by the ENC_HSPOL, ENC_VSPOL and ENC_FLDPOL (1xA4) registers respectively for both master and slave mode. In slave mode, the TW2835 can detect field polarity from vertical sync and horizontal sync via the ENC_FLD (1xA4) register or can detect vertical sync from the field flag via the ENC_VS (1xA4) register. The detailed timing diagram is illustrated in the following Fig 61.

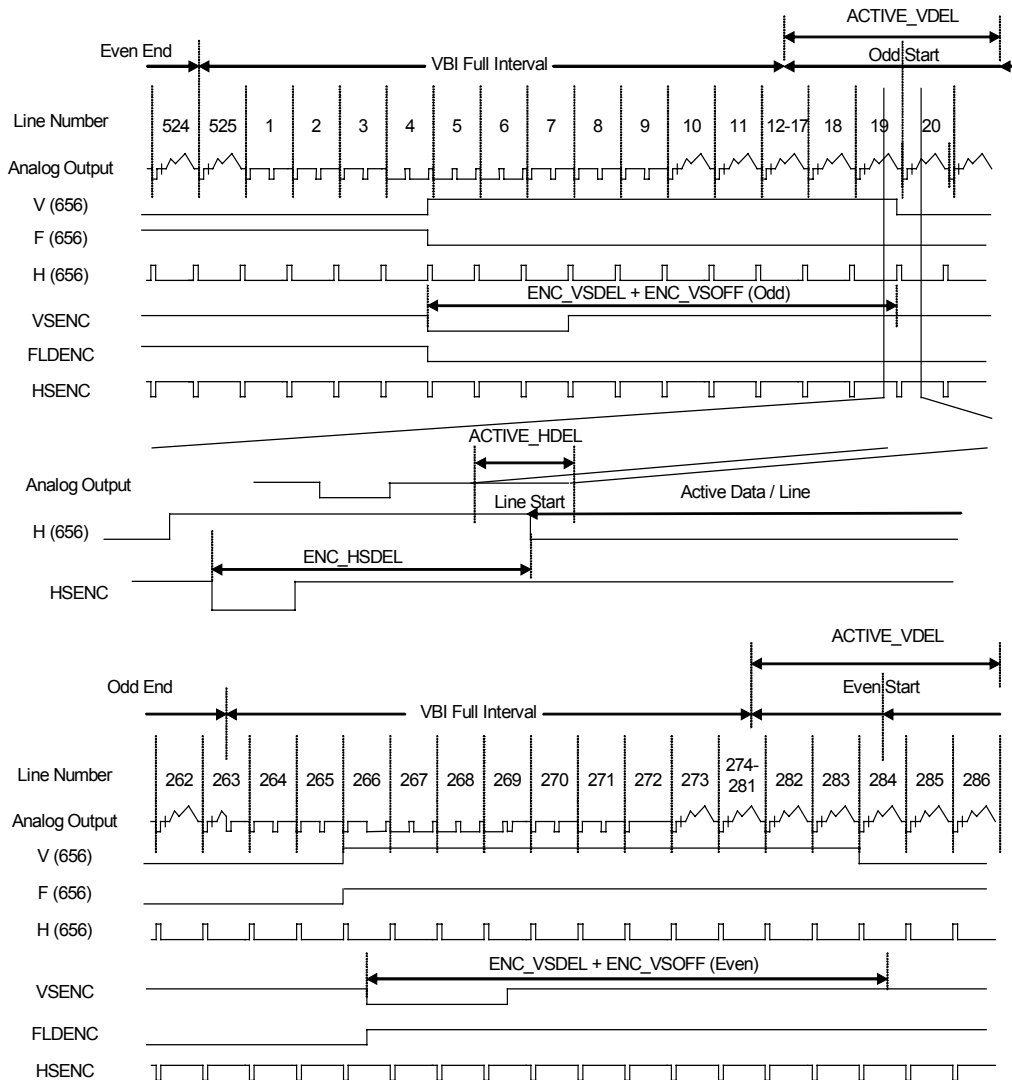

Fig 61 Horizontal and vertical timing control

The TW2835 provides or receives the timing signal through the HSENC, VSENC and FLDENC pins. To adjust the timing of those pins from video output, the TW2835 has the ENC_HSDEL (1xA6), ENC_VSDEL and ENC_VSOFF (1xA5) registers which control only the related signal timing regardless of analog and digital video output. Likewise, by controlling the ACTIVE_VDEL (1xA7) and ACTIVE_HDEL (1xA8) registers, only active video period can be shifted on horizontal and vertical direction independently. The shift of active video period produces the cropped video image because the timing signal is not changed even though active period is moved. So this feature is restricted to adjust video location in monitor for example.

To control the analog video timing differently from digital video output, the ACTIVE_MD (1xA8) register can be used. For ACTIVE_MD = "1", both analog and digital output timing can be controlled together, but for ACTIVE_MD = "0", the active delay of only analog video output can be controlled independently.

In cascade application, these timing related register should be controlled with same value for all cascade chips and be operated as only master mode because HSENC and VSENC pin is dedicated to cascade purpose. (Please refer to "Chip-to-Chip Cascade Operation" section on page 76)

Analog Video Output

The TW2835 supports analog video output using built-in video encoder, which generates composite or S-video with three 10 bit DAC for display and record path. The incoming digital video are adjusted for gain and offset according to NTSC or PAL standard. Both the luminance and chrominance are band-limited and interpolated to 27MHz sampling rate for digital to analog conversion. The NTSC output can be selected to include a 7.5 IRE pedestal. The TW2835 also provides internal test color bar generation.

Output Standard Selection

The TW2835 supports various video standard outputs via the SYS5060 (1x00) and ENC_FSC, ENC_PHALT, ENC_PED (1xA9) registers as described in the following Table 7.

Table 7 Analog output video standards

Format	Specification			Register			
	Line/Fv (Hz)	Fh (KHz)	Fsc (MHz)	SYS5060	ENC_FSC	ENC_PHALT	ENC_PED
NTSC-M	525/59.94	15.734	3.579545	0	0	0	1
NTSC-J							0
NTSC-4.43	525/59.94	15.734	4.43361875	0	1	0	1
NTSC-N	625/50	15.625	3.579545	1	0	0	0
PAL-BDGI	625/50	15.625	4.43361875	1	1	1	0
PAL-N							1
PAL-M	525/59.94	15.734	3.57561149	0	2	1	0
PAL-NC	625/50	15.625	3.58205625	1	3	1	0
PAL-60	525/59.94	15.734	4.43361875	0	1	1	0

If the ENC_ALTRST (1xA9) register is set to “1”, phase alternation can be reset every 8 field so that phase alternation keeps same phase every 8 field.

Luminance Filter

The bandwidth of luminance signal can be selected via the YBW (1xAA) register as shown in the following Fig 62.

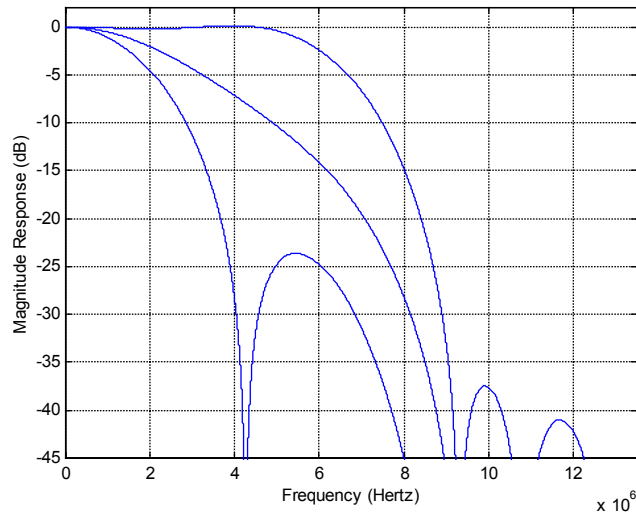

Fig 62 Characteristics of luminance filter

Chrominance Filter

The bandwidth of chrominance signal can be selected via the CBW (1xAA) register as shown in the following Fig 63.

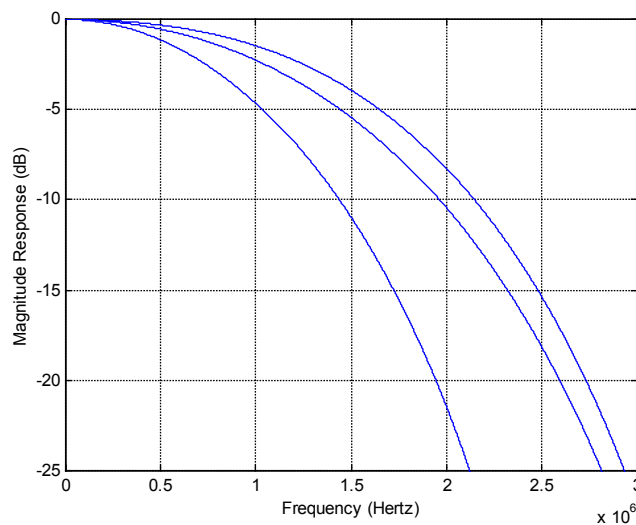

Fig 63 Characteristics of chrominance Filter

Digital-to-Analog Converter

The digital video data from video encoder is converted to analog video signal by DAC (Digital to Analog Converter). The analog video signal format can be selected for each DAC independently via the DAC_OUT_SEL (1xA1, 1xA2) register like the following Table 8. Each DAC can be disabled independently to save power by the DAC_PD (1xA1, 1xA2) register. The video output gain can also be controlled via the VOGAIN (0x41, 0x42) register.

Table 8 The available output combination of DAC

Path		Display				Record
Format		No Output	CVBS	Luma	Chroma	CVBS
Output	VAOYX	O	O	O	O	X
	VAOCX	O	O	O	O	X
	VAOYY	O	O	X	X	O

A simple reconstruction filter is required externally to reject noise as shown in the Fig 64.

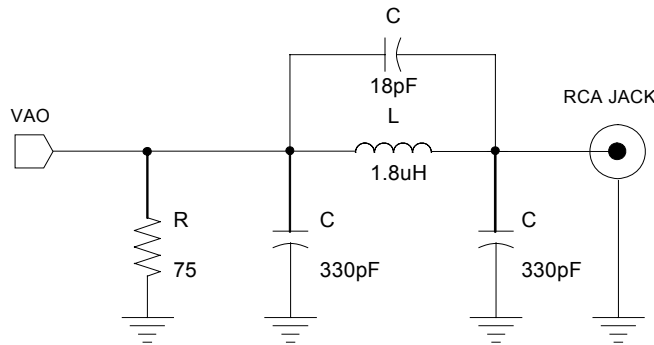

Fig 64 Example of reconstruction filter

Digital Video Output

The digital output data of ITU-R BT.656 format is synchronized with CLKVDOX/Y pin which is 27MHz for single output or 54MHz for dual output. Each digital data of display and record path can be output through VDOX and VDOY pin respectively on single output mode. For the dual output mode, both display and record path output can come out through only one VDOX or VDOY pin. The active video level of the ITU-R BT.656 can be limited to 1 ~ 254 via the CCIR_LMT (1xA4) register. In case that channel ID is located in active video period, the CCIR_LMT should be set to low for proper digital channel ID operation.

The following Table 9 shows the ITU-R BT.656 SAV and EAV code sequence.

Table 9 ITU-R BT.656 SAV and EAV code sequence

	Line		Condition			FVH			SAV/EAV Code Sequence			
	From	To	Field	Vertical	Horizontal	F	V	H	First	Second	Third	Fourth
60Hz (525Lines)	523 (1 ¹)	3	EVEN	Blank	EAV	1	1	1	0xFF	0x00	0x00	0xF1
					SAV			0				0xEC
	4	19	ODD	Blank	EAV	0	1	1				0xB6
					SAV			0				0xAB
	20	259 (263 ¹)	ODD	Active	EAV	0	0	1				0x9D
					SAV			0				0x80
	260 (264 ¹)	265	ODD	Blank	EAV	0	1	1				0xB6
					SAV			0				0xAB
	266	282	EVEN	Blank	EAV	1	1	1				0xF1
					SAV			0				0xEC
	283	522 (525 ¹)	EVEN	Active	EAV	1	0	1				0xDA
					SAV			0				0xC7
50Hz (625Lines)	1	22	ODD	Blank	EAV	0	1	1	0xFF	0x00	0x00	0xB6
					SAV			0				0xAB
	23	310	ODD	Active	EAV	0	0	1				0x9D
					SAV			0				0x80
	311	312	ODD	Blank	EAV	0	1	1				0xB6
					SAV			0				0xAB
	313	335	EVEN	Blank	EAV	1	1	1				0xF1
					SAV			0				0xEC
	336	623	EVEN	Active	EAV	1	0	1				0xDA
					SAV			0				0xC7
	624	625	EVEN	Blank	EAV	1	1	1				0xF1
					SAV			0				0xEC

Note 1. The number of () is ITU-R BT. 656 standard. The TW2835 also supports this standard by CCIR_STD register (1xA8 Bit[6]).

The TW2835 also supports ITU-R BT.601 interface through the VDOX and VDOY pin.

Single Output Mode

For the single output mode, each digital output data in display and record path can be output at 27MHz ITU-R BT 656 interface through VDOX and VDOY pin that are synchronized with CLKVDOX and CLKVDOY. The output data is selected by the CCIR_OUT (1xA3) register which selects the display path data for “0” and record path data for “1”. The timing diagram of single output mode for ITU-R BT.656 interface is shown in the following Fig 65.

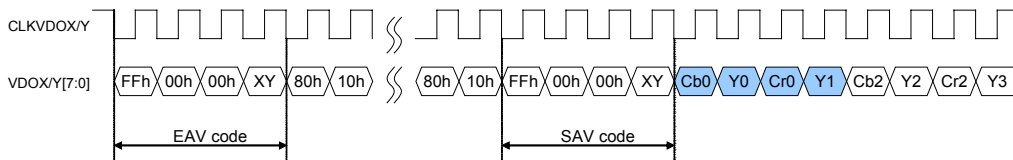

Fig 65 Timing diagram of single output mode for 656 Interface

The TW2835 also supports 13.5MHz ITU-R BT 601 interface through VDOX and VDOY pin via the CCIR_601 (1xA3) register. The output data is selected via the CCIR_OUT register which chooses the display path data for “0” and record path data for “1”. The timing diagram of single output mode for ITU-R BT 601 interface is shown in the following Fig 66.

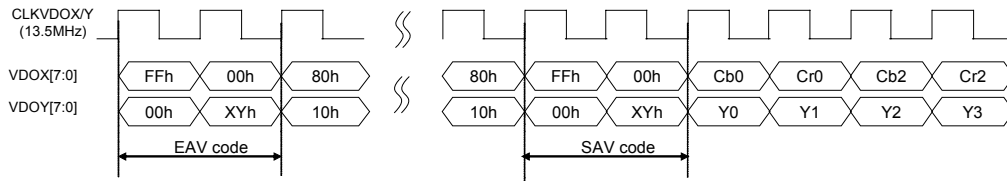

Fig 66 Timing diagram of single output mode for 601 Interface

The video output is synchronized with CLKVDOX and CLKVDOY pins whose phase and frequency can be controlled by the ENC_CLK_FR_X, ENC_CLK_FR_Y, ENC_CLK_PH_X and ENC_CLK_PH_Y (1xAD) registers.

Dual Output Mode

The TW2835 also supports dual output mode that is time-multiplexed with display and record path data at 54MHz clock rate. The sequence is related with the CCIR_OUT (1xA3) register that the display path data precedes the record path for CCIR_OUT = “2” and the record path data precedes the display path for CCIR_OUT = “3”. This mode is useful to reduce number of pins for interface with other devices. The timing diagram of dual output mode for ITU-R BT 656 interface is illustrated in the Fig 67.

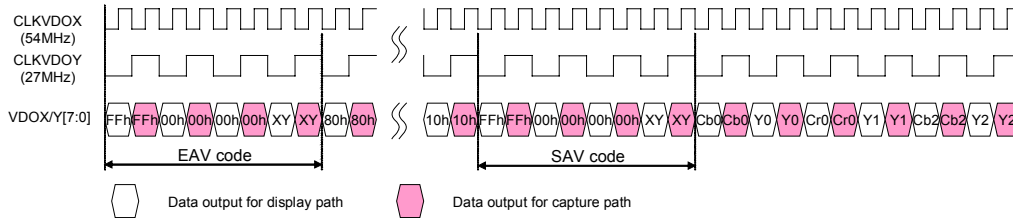

Fig 67 Timing diagram of dual output mode for 656 Interface

The TW2835 also supports dual output mode with 13.5MHz ITU-R BT 601 interface that is timing multiplexed to 27MHz through VDOX and VDOY pin via the CCIR_601 (1xA3) register. The sequence is determined by the CCIR_OUT register like 54MHz ITU-R BT.656 interface. The timing diagram of single output mode for ITU-R BT 601 interface is shown in the following Fig 68.

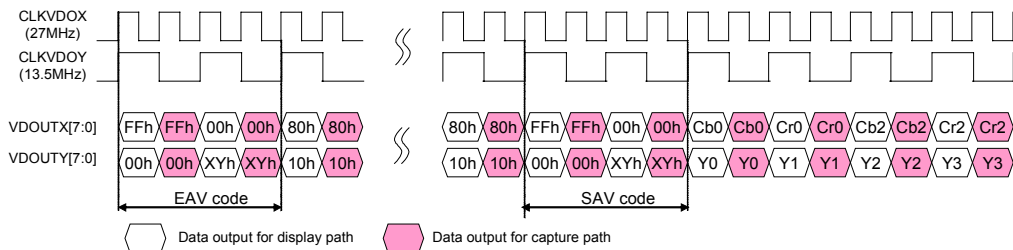

Fig 68 Timing diagram of dual output mode for 601 Interface

The video output is synchronized with CLKVDOX and CLKVDOY pins whose polarity and frequency can be controlled by the ENC_CLK_FR_X, ENC_CLK_FR_Y, ENC_CLK_PH_X and ENC_CLK_PH_Y registers.

Audio CODEC

The audio codec in the TW2835 is composed of 4 audio Analog-to-Digital converters, 1 Digital-to-Analog converter, audio mixer, digital serial audio interface and audio detector shown as the Fig 69. The TW2835 can accept 4 analog audio signals and 1 digital serial audio data and produce 1 mixing analog audio signal and 2 digital serial audio data.

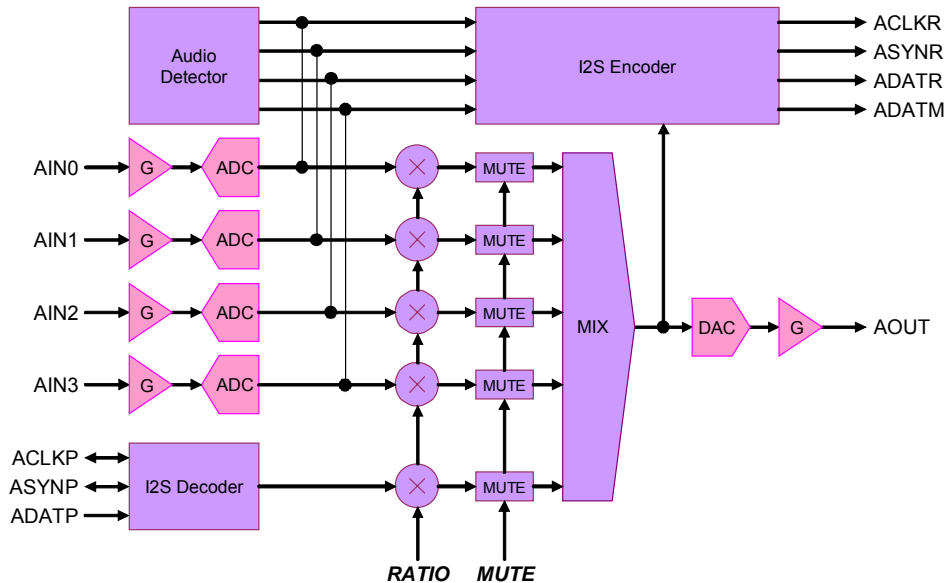

Fig 69 Block Diagram of Audio Codec

The level of analog audio input signal AIN0 ~ AIN3 can be adjusted respectively by internal programmable gain amplifiers that are defined via the AIGAIN0, AIGAIN1, AIGAIN1 and AIGAIN3 (0x60, 0x61) registers and then sampled by each Analog-to-Digital converters. The digital serial audio input data through the ACLKP, ASYNP and ADATP pin are used for playback function. To record audio data, the TW2835 provides the digital serial audio output via the ACLKR, ASYNR and ADATR pin.

The TW2835 can mix all of audio inputs including analog audio signal and digital audio data according to the predefined mixing ratio for each audio via the MIX_RATIO1 ~ MIX_RATIO4 and MIX_RATIOOP (0x6E, 0x6F, and 0x70) registers. This mixing audio output can be provided through the analog and digital interfaces. The embedded audio Digital-to-Analog converter supports the analog mixing audio output whose level can be controlled by programmable gain amplifier via the AOGAIN (0x70) register. The ADATM pin supports the digital mixing audio

output and its digital serial audio timings are provided through the ACLKR and ASYNR pins that are shared with the digital serial audio record timing pins.

Multi-Chip Operation

The TW2835 can be operated with the cascaded connection up to 16 chips that accept 64 channel audio inputs. The Fig 70 shows the example of 16 channel audio connection using 4 chips.

Each stage chip can accept 4 analog audio signals so that four cascaded chips through the ADATP and ADATM pin will be 16 channels audio controller. The first stage chip provides 16ch digital serial audio data for record. Even though the first stage chip has only 1 digital serial audio data pin ADATR for record, the TW2835 can generate 16 channel data simultaneously using multi-channel method. Also, each stage chip can support 4 channel record outputs that are corresponding with analog audio inputs. This first stage chip can also output 16 channel mixing audio data by the digital serial audio data and analog audio signal. Each chip accepts the digital serial audio data for playback and converts it to analog signal through the Digital-to-Analog Converter.

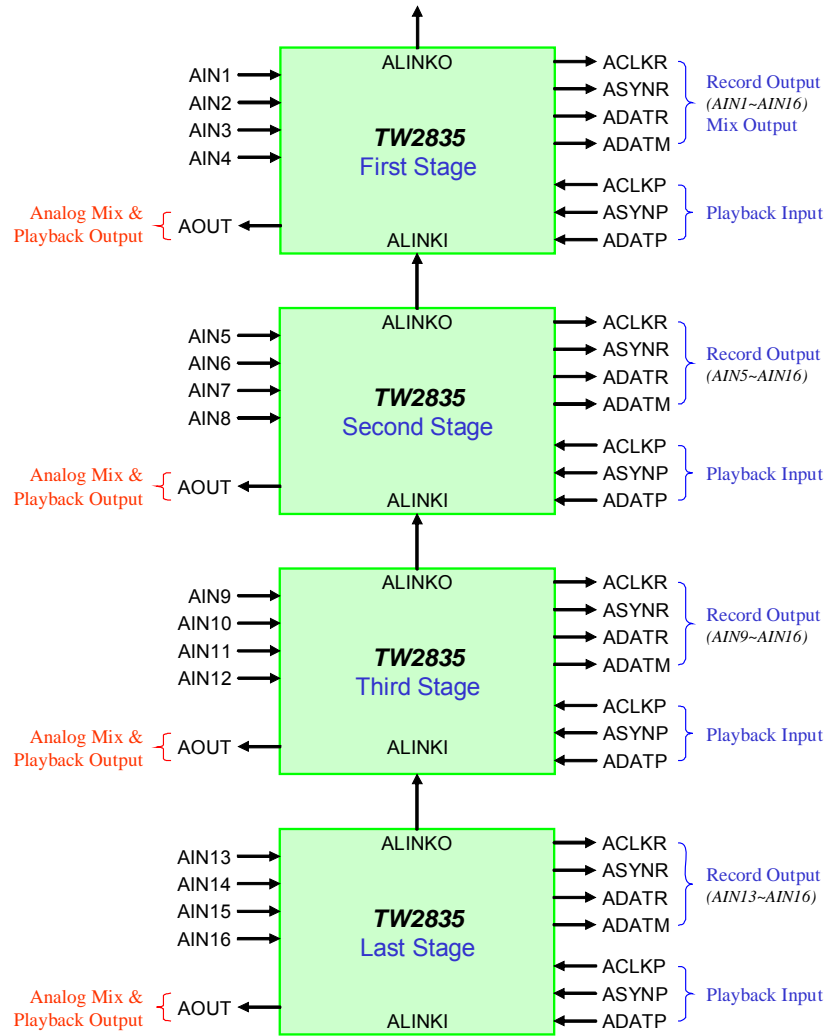
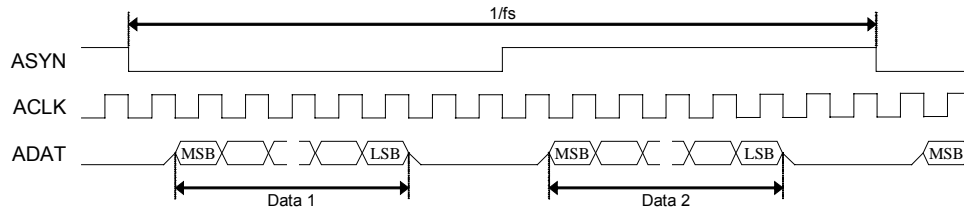

Fig 70 Connection for Multi-chip Operation

Serial Audio Interface

There are 3 kinds of digital serial audio interfaces in the TW2835, the first is a recording output, the second is a mixing output and the third is a playback input. These 3 digital serial audio interfaces follow a standard I2S or DSP interface as shown in the Fig 71.



(a) I2S Format

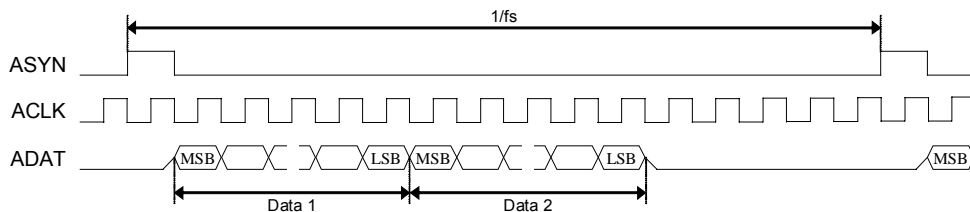

(b) DSP Format

Fig 71 Timing Chart of Serial Audio Interface

Playback Input

The serial interface using the ACLKP, ASYNP and ADATP pins accepts the digital serial audio data for the playback purpose. The ACLKP and ASYNP pins can be operated as master or slaver mode. For master mode, these pins work as output pin and generate the standard audio clock and synchronizing signal. For slaver mode, these pins are input mode and accept the standard audio clock and synchronizing signal. The ADATP pin is always input mode regardless of operating mode. One of audio data in left or right channel should be selected for playback audio by the PB_LRSEL (0x6C). The sampling frequency, bit width and number of audio bit are defined by the PB_SAMRATE, PB_BITWID and PB_BITRATE (0x6C) register.

Record Output

To record audio data, the TW2835 provides the digital serial audio data through the ACLKR, ASYNR and ADATR pins. The RM_SAMRATE, RM_BITWID and RM_BITRATE(0x62) registers define the sampling frequency, bit width and number of audio bit. Even though the standard I2S and DSP format can have only 2 audio data on left and right channel, the TW2835 can provide an extended I2S and DSP format which can have 16 channel audio data through ADATR pin. The R_MULTCH (0x63) defines the number of audio data to be recorded by the ADATR pin. The Fig 72 shows the digital serial audio data organization for multi-channel audio.

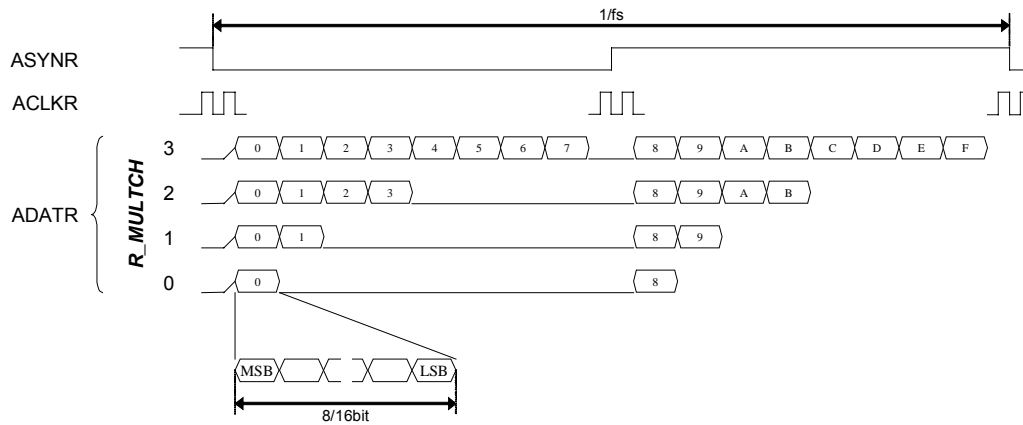

(a) I2S Format

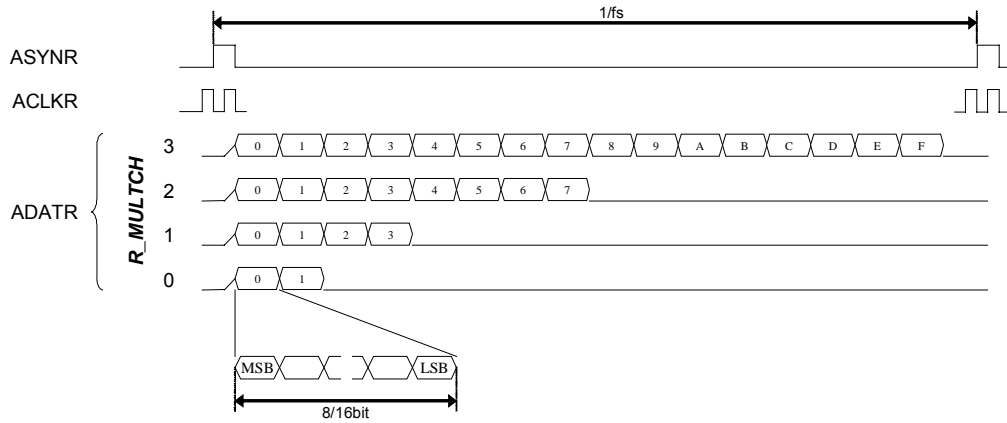

(b) DSP Format

Fig 72 Timing Chart of Multi-channel Audio Record

The following Table 10 shows the sequence of audio data to be recorded for each mode of the R_MULTCH (0x63) register. The sequences of 0 ~ F do not mean actual audio channel number but represent sequence only. The actual audio channel should be assigned to sequence 0 ~ F by the R_SEQ_0 ~ R_SEQ_F (0x64 ~ 0x6B) register. When the ADATM pin is used for record via the R_ADATM (0x63) register, the audio sequence of ADATM is showed also in Table 10.

Table 10 Sequence of Multi-channel Audio Record

I2S Format																	
R_MULTCH	Pin	Left Channel								Right Channel							
0	ADATR	0								8							
	ADATM	F								7							
1	ADATR	0	1							8	9						
	ADATM	F	E							7	6						
2	ADATR	0	1	2	3					8	9	A	B				
	ADATM	F	E	D	C					7	6	5	4				
3	ADATR	0	1	2	3	4	5	6	7	8	9	A	B	C	D	E	F
	ADATM	F	E	D	C	B	A	9	8	7	6	5	4	3	2	1	0
DSP Format																	
R_MULTCH	Pin	Left/Right Channel															
0	ADATR	0	1														
	ADATM	F	E														
1	ADATR	0	1	2	3												
	ADATM	F	E	D	C												
2	ADATR	0	1	2	3	4	5	6	7								
	ADATM	F	E	D	C	B	A	9	8								
3	ADATR	0	1	2	3	4	5	6	7	8	9	A	B	C	D	E	F
	ADATM	F	E	D	C	B	A	9	8	7	6	5	4	3	2	1	0

Mix Output

The digital serial audio data on the ADATM pin has 2 different audio data which are mixing audio and playback audio. The mixing digital serial audio data is the same as analog mixing output. The sampling frequency, bit width and number of audio for the ADATM pin are same as the ADATR pin because the ACLKR and ASYNR pins are shared with the ADATR and ADATM pins.

Analog Audio Output

The embedded audio Digital-to-Analog converter supports the analog mixing audio output whose level can be controlled via the AOGAIN (0x70) register. The audio DAC output can be disabled to save power by the ADAC_PD (0x4C) register. A simple reconstruction filter is required externally to reject noise as shown in the Fig 64.

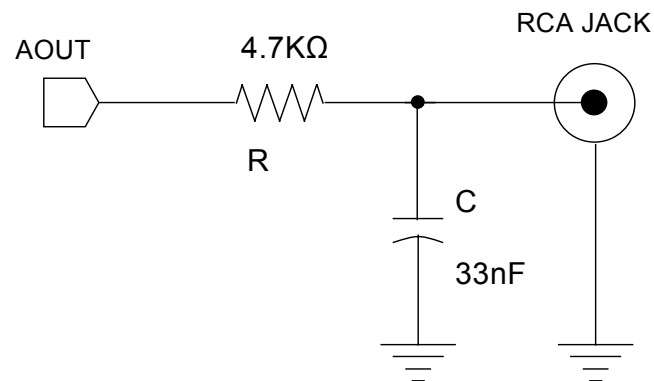

Fig 73 Example of audio DAC reconstruction filter

Host Interface

The TW2835 provides serial and parallel interfaces that can be selected by HSPB pin. When HSPB is low, the parallel interface is selected, the serial interface for high. Some of the interface pins serve a dual purpose depending on the working mode. The pins HALE and HDAT [7] in parallel mode become SCLK and SDAT pins in serial mode and the pins HDAT [6:1] and HCSB0 in parallel mode become slave address in serial mode respectively. Each interface protocol is shown in the following figures.

Table 11 Pin assignments for serial and parallel interface

Pin Name	Serial Mode	Parallel Mode
HSPB	HIGH	LOW
HALE	SCLK	AEN
HRDB	Not Used (VSSO)	RENB
HWRB	Not Used (VSSO)	WENB
HCSB0	Slave Address[0]	CSB0
HCSB1	Not Used (VSSO)	CSB1
HDAT[0]	Not Used (VSSO)	PDATA[0]
HDAT[1]	Slave Address[1]	PDATA[1]
HDAT[2]	Slave Address[2]	PDATA[2]
HDAT[3]	Slave Address[3]	PDATA[3]
HDAT[4]	Slave Address[4]	PDATA[4]
HDAT[5]	Slave Address[5]	PDATA[5]
HDAT[6]	Slave Address[6]	PDATA[6]
HDAT[7]	SDAT	PDATA[7]

Serial Interface

HDATA [6:1] and HCSB0 pins define slave address in serial mode. Therefore, any slave address can be assigned for full flexibility. The Fig 74 shows an illustration of serial interface for the case of slave address (Read : "0x85", Write : 0x84").

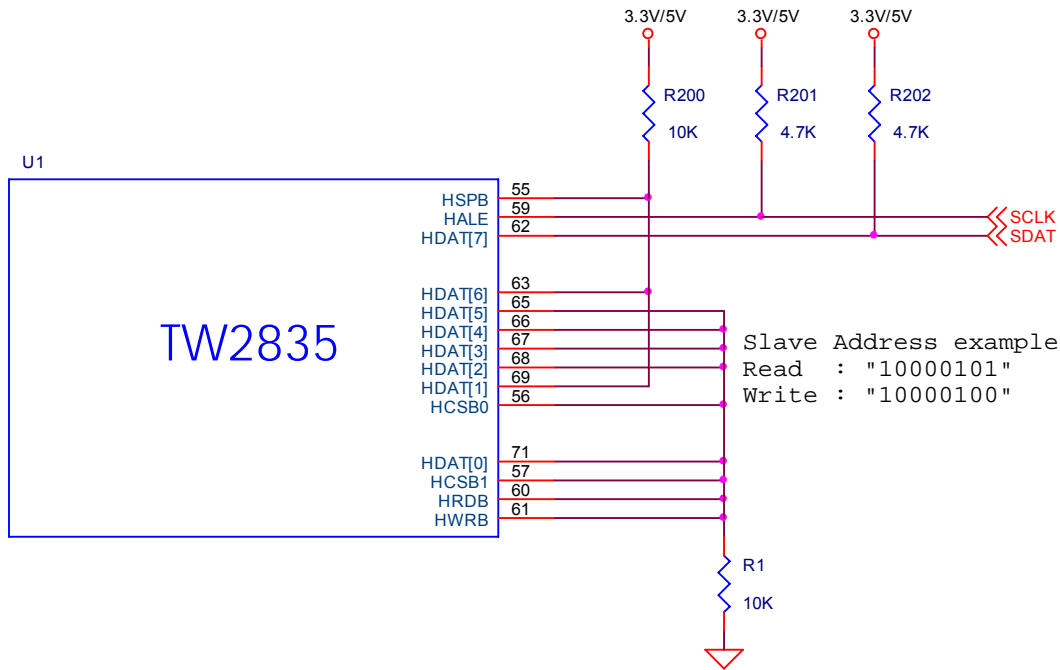

Fig 74 The serial interface for the case of slave address. (Read : "0x85", Write : "0x84")

The TW2835 has total 3 pages for registers (1 page can contain 256 registers) so that the page index [1:0] is used for selecting page of registers. Page 0 is assigned for video decoder, Page 1 is for video controller / encoder and Page 2 is for OSD / motion detector / Box / Mouse pointer.

The detailed timing diagram is illustrated in the Fig 75 and Fig 76.

The TW2835 also supports automatic index increment so that it can read or write continuous multi-bytes without restart. Therefore, the host can read or write multiple bytes in sequential order without writing additional slave address, page index and index address. The data transfer rate on the bus is up to 400K bits/s.

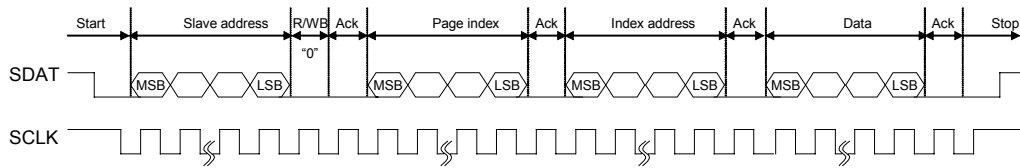

Fig 75 Write timing of serial interface

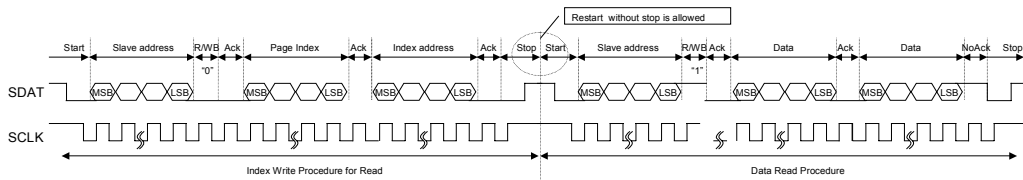

Fig 76 Read timing of serial interface

Parallel Interface

In parallel interface, page of registers can be selected by CSB0 and CSB1 pins, which are working as page index [1:0] in serial interface. Page number 0 is selected by CSB1 = "0" and CSB0 = "0", page number 1 is by CSB1 = "0" and CSB0 = "1", and page number 2 is by CSB1 = "1" and CSB0 = "0". The TW2835 also supports automatic index increment for parallel interface. The writing and reading timing is shown in the Fig 77 and Fig 78 respectively. The detail timing parameters are in Table 12.

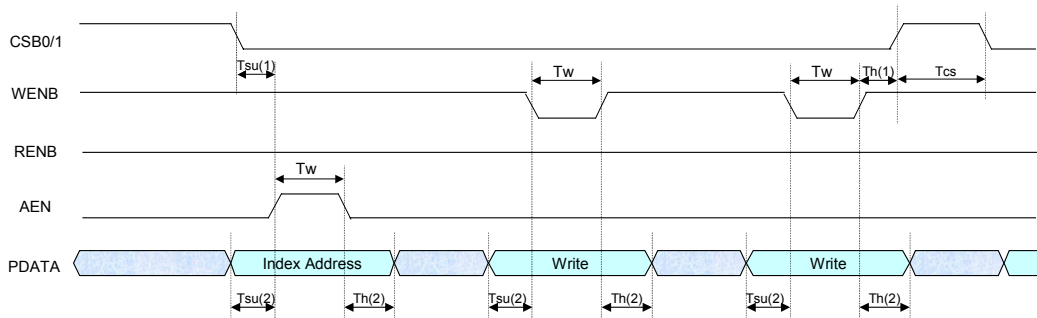

Fig 77 Write timing of parallel interface with auto index increment mode

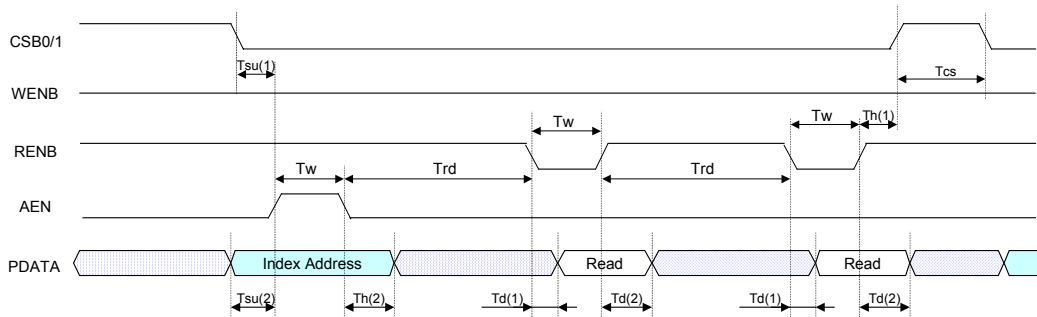

Fig 78 Read timing of parallel interface with auto index increment mode

Table 12 Timing parameters of parallel interface

Parameter	Symbol	Min	Typ	Max	Units
CSB setup until AEN active	Tsu(1)	10			ns
PDATA setup until AEN,WENB active	Tsu(2)	10			ns
AEN, WENB, RENB active pulse width	Tw	40			ns
CSB hold after WENB, RENB inactive	Th(1)	60			ns
PDATA hold after AEN,WENB inactive	Th(2)	20			ns
PDATA delay after RENB active	Td(1)			12	ns
PDATA delay after RENB inactive	Td(2)	60			ns
CSB inactive pulse width	Tcs	60			ns
RENB active delay after AEN inactive RENB active delay after RENB inactive	Trd	60			ns

Interrupt Interface

The TW2835 provides the interrupt request function via an IRQ pin. Any video loss, motion, blind, and night detection will make IRQ pin high or low whose polarity can be controlled via the IRQ_POL (1x76) register. The host can distinguish what event makes interrupt request to IRQ pin by reading the status of IRQENA_NOVID (1x78), IRQENA_MD (1x79), IRQENA_BD (1x7A) and IRQENA_ND (1x7B) registers that have different function for reading and writing. For writing mode, setting “1” to those registers enables to detect the related event. For reading mode, the state of those registers has two kinds of information depending on the IRQENA_RD (1x76) register. For IRQENA_RD = “1”, the state of those registers indicates the written value on the writing mode. For IRQENA_RD = “0”, the state of those registers denotes the related event status. The interrupt request will be cleared automatically by reading those registers when the IRQENA_RD is “0”. The following Fig 79 is show an illustration of the interrupt sequence.

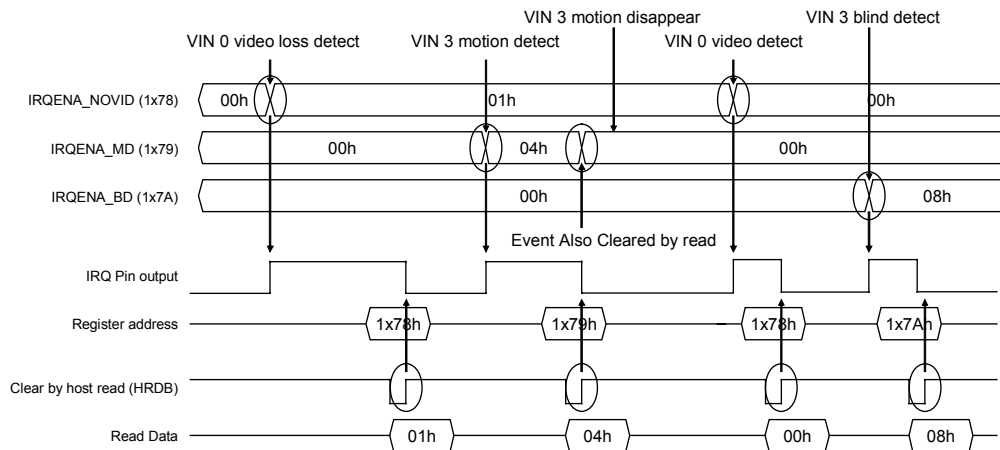

Fig 79 the illustration of Interrupt Sequence

The TW2835 also provides the status of video loss, motion, blind and night detection for individual channel through the MPP0/1 pins with the control of the MPPSET (1xB0, 1xB1, 1xB3, 1xB5) register.

MPP Pin Interface

The TW2835 provides the multi-purpose pin through the DLINKI and MPP1/2 pin that is controlled via the MPP_MD, MPP_SET, MPP_DATA (1xB0 ~ 1xB5) register. But, DLINK pin is also used for cascaded interconnection in cascaded application. The following Table 13 shows the detailed mode with the control of the related register.

Table 13 MPP Pin Interface Mode

MPP_MD	MPP_SET	I/O	MPP_DATA	Remark
0	0	In	Input Data from Pin	Default
	1	Out	Strobe_det_c	Capture path
	2		CHID_MUX[3:0]	
	3		CHID_MUX[7:4]	
	4		Mux_out_det[15:12]	
	5 – 7		-	Reserved
	8		Strobe_det_d	Display Path
	9 – 13		-	Reserved
	14		{1'b0, H, V, F}	BT. 656 Sync
	15		{hsync, vsync, field, link}	Analog Encoder Sync
1	0		Out	Write Data to Pin
	1	In	Input Data from Pin	
2	0	Out	Decoder H Sync	Bit[3:0] : VIN3 ~ VIN0
	1		Decoder V Sync	
	2		Decoder Field Sync	
	3		Decoder Ch 0/1 [7:4]	MSB for Ch 0/1
	4		Decoder Ch 0/1 [3:0]	LSB for Ch 0/1
	5		Decoder Ch 2/3 [7:4]	MSB for Ch 2/3
	6		Decoder Ch 2/3 [3:0]	LSB for Ch 2/3
	7		-	Reserved
	8		Novid_det_m	For VINA (ANA_SW = 0)
	9		Md_det_m	
	10		Bd_det_m	
	11		Nd_det_m	
	12		Novid_det_s	For VINB (ANA_SW = 1)
	13		Md_det_s	
14	Bd_det_s			
15	Nd_det_s			

The TW2835 also supports four channel real-time record output using MPP1 and MPP2 pin. The video output is synchronized with CLKMPP1 and CLKMPP2 pins whose polarity and frequency can be controlled via the DEC_CLK_FR_X, DEC_CLK_FR_Y, DEC_CLK_PH_X and DEC_CLK_PH_Y registers.

TW2835 Video and Audio Controller

Preliminary

Control Register

Register Map

For Video Decoder

Address				BIT7	BIT6	BIT5	BIT4	BIT3	BIT2	BIT1	BIT0	
VIN0	VIN1	VIN2	VIN3									
0x00	0x10	0x20	0x30	DET_FORMAT *			DET_COLOR *	LOCK_COLOR *	LOCK_GAIN *	LOCK_OFST *	LOCK_HPLL *	
0x01	0x11	0x21	0x31	IFMTMAN	IFORMAT			AGC	PEDEST	DET_NONSTD *	DET_FLD60 *	
0x02	0x12	0x22	0x32	HDELAY_XY [7:0]								
0x03	0x13	0x23	0x33	HACTIVE_XY [7:0]								
0x04	0x14	0x24	0x34	VDELAY_XY [7:0]								
0x05	0x15	0x25	0x35	VACTIVE_XY [7:0]								
0x06	0x16	0x26	0x36	0	0	VACTIVE_XY[8]	VDELAY_XY[8]	HACTIVE_XY [9:8]		HDELAY_XY [9:8]		
0x07	0x17	0x27	0x37	HUE								
0x08	0x18	0x28	0x38	SAT								
0x09	0x19	0x29	0x39	CONT								
0x0A	0x1A	0x2A	0x3A	BRT								
0x0B	0x1B	0x2B	0x3B	YBWI	COMBMD		YPEAK_MD	YPEAK_GN				
0x0C	0x1C	0x2C	0x3C	0	0	CKILL		CTI_GN				
0x0D	0x1D	0x2D	0x3D	0	0	0	0	ANA_SW	SW_RESET	WPEAK_MD		
0x0E	0x1E	0x2E	0x3E	0	0	0	1	0	0	0	1	
0x40	PB_SDEL			WPEAK_REF			WPEAK_RNG		WPEAK_TIME			
0x41	MPPCLK_OEB			VOGAINCX			0	VOGAINYX				
0x42	0	0	0	0	0	0	0	VOGAINYY				
0x43	0	1	0	0	GNTIME			OSTIME				
0x44	SLICELVL			HSWIDTH								
0x45	FLDMODE			VSMODE	FLDPOL	HSPOL	VSPOL	1	0			
0x46	IFCOMP			CLPF			ACCTIME		APCTIME			
0x47	0	1	C_CORE			0	CDEL					
0x48	U_GAIN											
0x49	V_GAIN											
0x4A	U_OFF											
0x4B	V_OFF											
0x4C	0	0	ADAC_PD	AADC_PD	VADC_PD3	VADC_PD2	VADC_PD1	VADC_PD0				
0x4D	0	0	0	0	NOVID_MD			1	1			
0x4E	0	0	0	0	0	1	0	1				
0x4F	0	0	0	0	0	0	0	0				
0x50	0	0	0	0	0	0	0	0				
0x51	1	0	0	0	0	0	0	0				
0x52	0	0	0	0	0	1	1	0				
0x53	0	0	0	0	0	0	0	0				
0x54	0	0	0	0	0	0	0	0				
0x55	FLD					VAV						
0x60	AIGAIN1					AIGAIN0						

TW2835 Video and Audio Controller

Preliminary

For Video Decoder

Address				BIT7	BIT6	BIT5	BIT4	BIT3	BIT2	BIT1	BIT0
VIN0	VIN1	VIN2	VIN3								
0x61				AIGAIN3				AIGAIN2			
0x62				M_PBSEL		M_RLSWAP	RM_BITRATE	RM_DATMOD	RM_SAMRATE	RM_BITWID	RM_SYNC
0x63				0	0	0	0	0	R_ADATM	R_MULTCH	
0x64				R_SEQ_1				R_SEQ_0			
0x65				R_SEQ_3				R_SEQ_2			
0x66				R_SEQ_5				R_SEQ_4			
0x67				R_SEQ_7				R_SEQ_6			
0x68				R_SEQ_9				R_SEQ_8			
0x69				R_SEQ_B				R_SEQ_A			
0x6A				R_SEQ_D				R_SEQ_C			
0x6B				R_SEQ_F				R_SEQ_E			
0x6C				0	PB_MASTER	PB_LRSEL	PB_BITRATE	PB_DATMOD	PB_SAMRATE	PB_BITWID	PB_SYNC
0x6D				0	0	MIX_DERATIO		MIX_MUTE			
0x6E				MIX_RATIO1				MIX_RATIO0			
0x6F				MIX_RATIO3				MIX_RATIO2			
0x70				AOGAIN				MIX_RATIOF			
0x71				0	1	MIX_MODE		MIX_OUTSEL			
0x72				0	0	0	0	0	0	0	0
0x73				0	0	0	0	0	0	0	0
0x74				0	0	0	0	0	0	0	0
0x80	0x90	0xA0	0xB0	DEC_PATH_X		0	0	VSFLT_X		HSFLT_X	
0x81	0x91	0xA1	0xB1	VSCALE_X [15:8]							
0x82	0x92	0xA2	0xB2	VSCALE_X [7:0]							
0x83	0x93	0xA3	0xB3	HSCALE_X [15:8]							
0x84	0x94	0xA4	0xB4	HSCALE_X [7:0]							
0x85	0x95	0xA5	0xB5	0	0	0	0	VSFLT_PB		HSFLT_PB	
0x86	0x96	0xA6	0xB6	VSCALE_PB [15:8]							
0x87	0x97	0xA7	0xB7	VSCALE_PB [7:0]							
0x88	0x98	0xA8	0xB8	HSCALE_PB [15:8]							
0x89	0x99	0xA9	0xB9	HSCALE_PB [7:0]							
0x8A	0x9A	0xAA	0xBA	0 / 1 / 2 / 3		VSCALE_Y	HSCALE_Y	VSFLT_Y		HSFLT_Y	
0x8B	0x9B	0xAB	0xBB	HDELAY_PB [7:0]							
0x8C	0x9C	0xAC	0xBC	HACTIVE_PB [7:0]							
0x8D	0x9D	0xAD	0xBD	VDELAY_PB [7:0]							
0x8E	0x9E	0xAE	0xBE	VACTIVE_PB [7:0]							
0x8F	0x9F	0xAF	0xBF	0	0	VACTIVE_PB [8]	VDELAY_PB [8]	HACTIVE_PB [9:8]		HDELAY_PB [9:8]	
0xC0				0	PB_FLDPOL	0	0	MAN_PBCROP	PB_CROP_MD	PB_ACT_MD	
0xC1				LIM_656_PB	LIM_656_X	LIM_656_Y1		LIM_656_Y0			
0xC2				0	LIM_656_DEC	LIM_656_Y3		LIM_656_Y2			
0xC3				BGNDEN_PB				BGNDCOL	AUTOBGNDPB	AUTOBGNDY	AUTOBGNDX
0xC4				BGNDEN_Y				BGNDEN_X			
0xC5				PAL_DLY_Y				PAL_DLY_X			
0xC6				1	1	1	1	PAL_DLY_PB			
0xC7				1	1	1	1	1	1	1	1

TW2835 Video and Audio Controller

Preliminary

For Video Decoder

Address				BIT7	BIT6	BIT5	BIT4	BIT3	BIT2	BIT1	BIT0
VIN0	VIN1	VIN2	VIN3								
0xC8				0	0	0	0	0	FLD_OFST_PB	FLD_OFST_Y	FLD_OFST_X
0xC9				0	0	1	1	1	1	0	0
0xCA				0	OUT_CHID	0	0	1	1	1	1
0xFE				0x28*							

- Notes
1. "*" stand for read only register
 2. VIN0 ~ VIN3 stand for video input 0 ~ video input 3.

For Video Controller (Display path)

Address								BIT7	BIT6	BIT5	BIT4	BIT3	BIT2	BIT1	BIT0
CH0	CH1	CH2	CH3	CH4	CH5	CH6	CH7								
1x00								SYS_5060	OVERLAY	LINK_LAST_X	LINK_LAST_Y	LINK_EN_X	LINK_EN_Y	LINK_NUM	
1x01								0	0	0	TBLINK	FRZ_FRAME	DUAL_PAGE	STRB_FLD	
1x02								RECALL_FLD	SAVE_FLD		SAVE_HID	SAVE_ADDR			
1x03								SAVE_REQ							
1x04								STRB_REQ							
1x05								NOVID_MODE		0	0	0	AUTO_ENHACE	INVALID_MODE	
1x06								MUX_MODE	0	MUX_FLD		0	0	0	0
1x07								STRB_AUTO	0	0	INTR_REQX	INTR_CH			
1x08								MUX_OUT_CH0				MUX_OUT_CH1			
1x09								MUX_OUT_CH2				MUX_OUT_CH3			
1x0A								CHID_MUX_OUT							
1x0B								ZM_EVEN_OS		ZM_ODD_OS		FR_EVEN_OS		FR_ODD_OS	
1x0C								ZMENA	H_ZM_MD	ZMBNDCOL	ZMBNDEN	ZMAREAEN	ZMAREA		
1x0D								ZOOMH							
1x0E								ZOOMV							
1x0F								FRZ_FLD		BNDCOL		BGDCOL		BLKCOL	
1x10	1x18	1x20	1x28	1x13	1x1B	1x23	1x2B	CH_EN	POP_UP	FUNC_MODE		ANA_PATH_SEL	PB_PATH_EN	Reserved	
1x11	1x19	1x21	1x29	1x14	1x1C	1x24	1x2C	RECALL_CH	FRZ_CH	H_MIRROR	V_MIRROR	ENHANCE	BLANK	BOUND	BLINK
1x12	1x1A	1x22	1x2A	1x15	1x1D	1x25	1x2D	0	0	FIELD_OP	DVR_IN	RECALL_ADDR			
1x16	1x1E	1x26	1x2E	1x16	1x1E	1x26	1x2E	PB_AUTO_EN	FLD_CONV	PB_STOP	EVENT_PB	PB_CH_NUM			
1x17	1x1F	1x27	1x2F	1x17	1x1F	1x27	1x2F	0	0	0	0	0	0	0	0
1x30	1x34	1x38	1x3C	1x40	1x44	1x48	1x4C	PICHL							
1x31	1x35	1x39	1x3D	1x41	1x45	1x49	1x4D	PICHR							
1x32	1x36	1x3A	1x3E	1x42	1x46	1x4A	1x4E	PICVT							
1x33	1x37	1x3B	1x3F	1x43	1x47	1x4B	1x4F	PICVB							

- Notes
1. "*" stand for read only register
 2. CH0 ~ CH7 stand for channel 0 ~ channel 7.

TW2835 Video and Audio Controller

Preliminary

For Video Controller (Record path)

Address				BIT7	BIT6	BIT5	BIT4	BIT3	BIT2	BIT1	BIT0
CH0	CH1	CH2	CH3								
1x50				MEDIAN_MD	TM_SLOP			TM_THR			
1x51				0	FRAME_OP	FRAME_FLD	DIS_MODE	0	0	SIZE_MODE	
1x52				TBLINK	FRZ_FRAME	TM_WIN_MD		0	0	0	0
1x53				0	0	0	0	0	0	0	0
1x54				0	STRB_FLD		DUAL_PAGE	STRB_REQ			
1x55				NOVID_MODE		0	CH_START	0	AUTO_NR_EN	INVALID_MODE	
1x56				MUX_MODE	TRIG_MODE	MUX_FLD		PIN_TRIG_MD		PIN_TRIG_EN	
1x57				STRB_AUTO		QUE_SIZE					
1x58				QUE_PERIOD[7:0]							
1x59				QUE_PERIOD[9:8]		EXT_TRIG	INTR_REQY	MUX_WR_CH			
1x5A				QUE_WR	QUE_ADDR						
1x5B				0	Q_POS_RD_CTL	Q_DATA_RD_CTL		MUX_SKIP_EN	ACCU_TRIG	QUE_CNT_RST	QUE_POS_RST
1x5C				MUX_SKIP_CH[15:8]							
1x5D				MUX_SKIP_CH[7:0]							
1x5E				CHID_MUX_OUT							
1x5F				FRZ_FLD		BNDCOL		BGDCOL		BLKCOL	
1x60	1x63	1x66	1x69	CH_EN	POP_UP	FUNC_MODE		NR_EN_DM	NR_EN	DEC_PATH_Y	
1x61	1x64	1x67	1x6A	0	FRZ_CH	H_MIRROR	V_MIRROR	0	BLANK	BOUND	BLINK
1x62	1x65	1x68	1x6B	0	0	FIELD_OP	0	0	0	0	0
1x6C				PIC_SIZE3		PIC_SIZE2		PIC_SIZE1		PIC_SIZE0	
1x6D				PIC_POS3		PIC_POS2		PIC_POS1		PIC_POS0	
1x6E				MUX_OUT_CH0				MUX_OUT_CH1			
1x6F				MUX_OUT_CH2				MUX_OUT_CH3			
1x70				POS_CTL_EN	POS_TRIG_MODE	POS_TRIG	POS_INTR	0	POS_RD_CTL	POS_DATA_RD_CTL	
1x71				POS_PERIOD[9:8]		POS_FLD_MD	POS_SIZE				
1x72				POS_QUE_PER[7:0]							
1x73				POS_CH0				POS_CH1			
1x74				POS_CH2				POS_CH3			
1x75				POS_QUE_WR	POS_CNT_RST	POS_QUE_RST	POS_QUE_ADDR				
1x76				IRQENA_RD	0	0	0	0	0	IRQ_POL	IRQ_RPT
1x77				IRQ_PERIOD							
1x78				IRQENA_NOVID_S				IRQENA_NOVID_M			
1x79				IRQENA_MD_S				IRQENA_MD_M			
1x7A				IRQENA_BD_S				IRQENA_BD_M			
1x7B				IRQENA_ND_S				IRQENA_ND_M			
1x7C				DET_NOVID_PB				0	0	0	0
1x7D				0	0	0	0	0	0	0	0
1x7E				1	SYNC_DEL			MCLK_CTL			
1x7F				MEM_INIT	0	T_CASCADE_EN	0	0	1	0	0
1x80				VIS_ENA	VIS_AUTO_EN	AUTO_RPT_EN	VIS_DET_EN	VIS_USER_EN	VIS_CODE_EN	VIS_RIC_EN	1
1x81				VIS_PIXEL_HOS							
1x82				VIS_FLD_OS		0	VIS_PIXEL_WIDTH				
1x83				0	VIS_DM_MD	0	VIS_LINE_OS				
1x84				VIS_HIGH_VAL							

TW2835 Video and Audio Controller

Preliminary

For Video Controller (Record path)

Address				BIT7	BIT6	BIT5	BIT4	BIT3	BIT2	BIT1	BIT0
CH0	CH1	CH2	CH3								
1x85				VIS_LOW_VAL							
1x86				AUTO_VBI_DET	0	VBI_ENA	VBI_CODE_EN	VBI_RIC_ON	VBI_FLT_EN	CHID_RD_TYPE	VBI_RD_CTL
1x87				VBI_PIXEL_HOS							
1x88				VBI_FLD_OS		VAV_CHK	VBI_PIXEL_WIDTH				
1x89				VBI_SIZE			VBI_LINE_OS				
1x8A				VBI_MID_VALUE							
1x8B				DET_CHID_TYPE/{3'b0, auto_valid, det_valid, user_valid}							
1x8C				AUTO_CHID0							
1x8D				AUTO_CHID1							
1x8E				AUTO_CHID2							
1x8F				AUTO_CHID3							
1x90				USER_CHID0							
1x91				USER_CHID1							
1x92				USER_CHID2							
1x93				USER_CHID3							
1x94				USER_CHID4							
1x95				USER_CHID5							
1x96				USER_CHID6							
1x97				USER_CHID7							
1x98				DET_CHID0							
1x99				DET_CHID1							
1x9A				DET_CHID2							
1x9B				DET_CHID3							
1x9C				DET_CHID4							
1x9D				DET_CHID5							
1x9E				DET_CHID6							
1x9F				DET_CHID7							

- Notes
1. "*" stand for read only register
 2. CH0 ~ CH3 stand for channel 0 ~ channel 3.

TW2835 Video and Audio Controller

Preliminary

For Video Output

Address	BIT7	BIT6	BIT5	BIT4	BIT3	BIT2	BIT1	BIT0
1xA0	ENC_IN_X		ENC_IN_Y		CCIR_IN_X		CCIR_IN_Y	
1xA1	DAC_PD_CX	0	DAC_OUT_YX		DAC_PD_YX	0	DAC_OUT_CX	
1xA2	1	DAC_OUT_YY		DAC_PD_YY	0	0	0	0
1xA3	CCIR_601_X	0	CCIR_OUT_X		CCIR601_Y	0	CCIR_OUT_Y	
1xA4	ENC_MODE	CCIR_LMT	ENC_VS	ENC_FLD	CCIR_FLDPOL	ENC_HSPOL	ENC_VSPOL	ENC_FLDPOL
1xA5	ENC_VSOFF			ENC_VSDEL				
1xA6	ENC_HSDEL[7:0]							
1xA7	ENC_HSDEL[9:8]		TST_FSC_FREE	ACTIVE_VDEL				
1xA8	ACTIVE_MD	CCIR_STD	ACTIVE_HDEL					
1xA9	ENC_FSC		0	0	1	ENC_PHALT	ENC_ALTRST	ENC_PED
1xAA	ENC_CBW_X		ENC_YBW_X		ENC_CBW_Y		ENC_YBW_Y	
1xAB	0	HOUT	VOUT	FOUT	ENC_BAR_X	ENC_CKILL_X	ENC_BAR_Y	ENC_CKILL_Y
1xAC	ENC_CLK_FR_X		ENC_CLK_PH_X		ENC_CLK_CTL_X			
1xAD	ENC_CLK_FR_Y		ENC_CLK_PH_Y		ENC_CLK_CTL_Y			
1xAE	DEC_CLK_FR_X		DEC_CLK_PH_X		DEC_CLK_CTL_X			
1xAF	DEC_CLK_FR_Y		DEC_CLK_PH_Y		DEC_CLK_CTL_Y			
1xB0	0	0	MPP_MD2		MPP_MD1		MPP_MD0	
1xB1	MPP0_SET_MSB				MPP0_SET_LSB			
1xB2	MPP0_DATA_MSB				MPP0_DATA_LSB			
1xB3	MPP1_SET_MSB				MPP1_SET_LSB			
1xB4	MPP1_DATA_MSB				MPP1_DATA_LSB			
1xB5	MPP2_SET_MSB				MPP2_SET_LSB			
1xB6	MPP2_DATA_MSB				MPP2_DATA_LSB			
1xB7	MEM_INIT_DET	0	0	0	0	0	0	0
1xB8	0							
1xB9	0	0	0	0	0	0	0	0
1xBA	0	0	0	0	0	0	0	0
1xBB	0	0	0	0	0	0	0	0
1xBC	0	0	0	0	0	0	0	0
1xBD	0		0		0		0	
1xBE	0		0		0		0	
1xBF	0		0		0		0	

Notes 1. "*" stand for read only register

TW2835 Video and Audio Controller

Preliminary

For Character and Mouse Overlay

Address	BIT7	BIT6	BIT5	BIT4	BIT3	BIT2	BIT1	BIT0	
2x00	OSD_BUF_DATA[31:24]								
2x01	OSD_BUF_DATA[23:16]								
2x02	OSD_BUF_DATA[15:8]								
2x03	OSD_BUF_DATA[7:0]								
2x04	OSD_BUF_WR	OSD_BUF_RD_MD	0	0	OSD_BUF_ADDR				
2x05	OSD_START_HPOS								
2x06	OSD_END_HPOS								
2x07	OSD_START_VPOS[7:0]								
2x08	OSD_END_VPOS[7:0]								
2x09	OSD_BL_SIZE				OSD_START_VPOS[9:8]		OSD_END_VPOS[9:8]		
0x0A	OSD_MEM_WR	OSD_ACC_EN	OSD_MEM_PATH	OSD_WR_PAGE			0	OSD_INDEX_RD_MD	
0x0B	OSD_INDEX_Y								
0x0C	OSD_INDEX_CB								
2x0D	OSD_INDEX_CR								
2x0E	OSD_INDEX_WR	OSD_INDEX_ADDR							
2x0F	0	OSD_RD_PAGE			OSD_FLD_X		OSD_FLD_Y		
2x10	CUR_ON_X	CUR_ON_Y	CUR_TYPE	CUR_SUB	CUR_BLINK	0	CUR_HP [0]	CUR_VP [0]	
2x11	CUR_HP								
2x12	CUR_VP								
2x13	CLUT0_Y								
2x14	CLUT0_CB								
2x15	CLUT0_CR								
2x16	CLUT1_Y								
2x17	CLUT1_CB								
2x18	CLUT1_CR								
2x19	CLUT2_Y								
2x1A	CLUT2_CB								
2x1B	CLUT2_CR								
2x1C	CLUT3_Y								
2x1D	CLUT3_CB								
2x1E	CLUT3_CR								
2x1F	TBLINK OSD		ALPHA OSD		ALPHA 2DBOX		ALPHA BOX		

Notes

TW2835 Video and Audio Controller

Preliminary

For Single Box

Address				BIT7	BIT6	BIT5	BIT4	BIT3	BIT2	BIT1	BIT0
B0	B1	B2	B3								
2x20	2x26	2x2C	2x32	BOX_BNDCOL		BOX_PLNMIX_Y	BOX_BNDEN_Y	BOXPLNEN_Y	BOX_PLNMIX_X	BOX_BNDEN_X	BOXPLNEN_X
2x21	2x27	2x2D	2x33	BOX_PLNCOL				BOX_HL[0]	BOX_HW[0]	BOX_VT[0]	BOX_VW[0]
2x22	2x28	2x2E	2x34					BOX_HL[8:1]			
2x23	2x29	2x2F	2x35					BOX_HW[8:1]			
2x24	2x2A	2x30	2x36					BOX_VT[8:1]			
2x25	2x2B	2x31	2x37					BOX_VW[8:1]			
2x38				0	0	0	0	OVL_MD X		OVL_MD Y	

Notes 1. B0 ~ B3 stand for single box 0 to 3.

For 2D Arrayed Box Overlay

Address				BIT7	BIT6	BIT5	BIT4	BIT3	BIT2	BIT1	BIT0
2DBC	2DB1	2DB2	2DB3								
2x5B				MASKAREA0_COL				DETAREA0_COL			
2x5C				MASKAREA1_COL				DETAREA1_COL			
2x5D				MASKAREA2_COL				DETAREA2_COL			
2x5E				MASKAREA3_COL				DETAREA3_COL			
2x5F				MDBND3_COL		MDBND2_COL		MDBND1_COL		MDBND0_COL	
2x60	2x68	2x70	2x78	2DBOX_EN X	2DBOX_EN Y	2DBOX_MODE	2DBOX_CUREN	2DBOX_MIX	2DBOX_IN_SEL		
2x61	2x69	2x71	2x79	2DBOX_HINV	2DBOX_VINV	MASKAREA_EN	DETAREA_EN	2DBOX_BND_EN	0	2DBOX_HL[0]	2DBOX_VT[0]
2x62	2x6A	2x72	2x7A					2DBOX_HL[8:1]			
2x63	2x6B	2x73	2x7B					2DBOX_HW			
2x64	2x6C	2x74	2x7C					2DBOX_VT[8:1]			
2x65	2x6D	2x75	2x7D					2DBOX_VW			
2x66	2x6E	2x76	2x7E	2DBOX_HNUM				2DBOX_VNUM			
2x67	2x6F	2x77	2x7F	2DBOX_CURHP				2DBOX_CURVP			

Notes 1. 2DB0 ~ 2DB3 stand for 2D arrayed box 0 to 3.

TW2835 Video and Audio Controller

Preliminary

For Motion Detector

Address				BIT7	BIT6	BIT5	BIT4	BIT3	BIT2	BIT1	BIT0		
VIN0	VIN1	VIN2	VIN3										
2x80	2xA0	2xC0	2xE0	MD_DIS	MD_REFFLD	BD_CELSENS		BD_LVSENS					
2x81	2xA1	2xC1	2xE1	ND_LVSENS				ND_TMPSENS					
2x82	2xA2	2xC2	2xE2	MD_MASK_RD_MD		MD_FLD		MD_ALIGN					
2x83	2xA3	2xC3	2xE3	MD_CELLSSENS		MD_DUAL_EN	MD_LVSENS						
2x84	2xA4	2xC4	2xE4	MD_STRB_EN	MD_STRB	MD_SPEED							
2x85	2xA5	2xC5	2xE5	MD_TMPSENS				MD_SPSSENS					
2x86	2xA6	2xC6	2xE6	MD_MASK[15:8]									
2x88	2xA8	2xC8	2xE8										
2x8A	2xAA	2xCA	2xEA										
2x8C	2xAC	2xCC	2xEC										
2x8E	2xAE	2xCE	2xEE										
2x90	2xB0	2xD0	2xF0										
2x92	2xB2	2xD2	2xF2										
2x94	2xB4	2xD4	2xF4										
2x96	2xB6	2xD6	2xF6										
2x98	2xB8	2xD8	2xF8										
2x9A	2xBA	2xDA	2xFA										
2x9C	2xBC	2xDC	2xFC										
2x87	2xA7	2xC7	2xE7										
2x89	2xA9	2xC9	2xE9										
2x8B	2xAB	2xCB	2xEB	MD_MASK[7:0]									
2x8D	2xAD	2xCD	2xED										
2x8F	2xAF	2xCF	2xEF										
2x91	2xB1	2xD1	2xF1										
2x93	2xB3	2xD3	2xF3										
2x95	2xB5	2xD5	2xF5										
2x97	2xB7	2xD7	2xF7										
2x99	2xB9	2xD9	2xF9										
2x9B	2xBB	2xDB	2xFB										
2x9D	2xBD	2xDD	2xFD										
2x9E	2xBE	2xDE	2xFE	DET_NOVID_S	DET_MD_S	DET_BD_S	DET_ND_S	DET_NOVID_M	DET_MD_M	DET_BD_M	DET_ND_M		

Notes 1. VIN0 ~ VIN3 stand for video input 0 ~ video input 3.

Recommended Value
For Video Decoder

Address				NTSC				PAL			
VIN0	VIN1	VIN2	VIN3	1 CH	4 CH	9 CH	16 CH	1 CH	4 CH	9 CH	16 CH
0x00	0x10	0x20	0x30	8'h00				8'h00			
0x01	0x11	0x21	0x31	C8				88			
0x02	0x12	0x22	0x32	20				20			
0x03	0x13	0x23	0x33	D0				D0			
0x04	0x14	0x24	0x34	06				05			
0x05	0x15	0x25	0x35	F0				20			
0x06	0x16	0x26	0x36	08				28			
0x07	0x17	0x27	0x37	80				80			
0x08	0x18	0x28	0x38	80				80			
0x09	0x19	0x29	0x39	80				80			
0x0A	0x1A	0x2A	0x3A	80				80			
0x0B	0x1B	0x2B	0x3B	02				82			
0x0C	0x1C	0x2C	0x3C	06				06			
0x0D	0x1D	0x2D	0x3D	00				00			
0x0E	0x1E	0x2E	0x3E	11				11			
	0x40			00				00			
	0x41			77				77			
	0x42			07				07			
	0x43			45				45			
	0x44			A0				A0			
	0x45			D0				D0			
	0x46			2F				2F			
	0x47			64				64			
	0x48			80				80			
	0x49			80				80			
	0x4A			82				82			
	0x4B			82				82			
	0x4C			00				00			
	0x4D			0F				0F			
	0x4E			05				05			
	0x4F			00				00			
	0x50			00				00			
	0x51			80				80			
	0x52			06				06			
	0x53			00				00			
	0x54			00				00			
	0x55			00				00			
	0x60			88				88			
	0x61			88				88			
	0x62			00				00			
	0x63			00				00			
	0x64			10				10			
	0x65			32				32			
	0x66			54				54			
	0x67			76				76			
	0x68			98				98			

Address				NTSC				PAL			
VIN0	VIN1	VIN2	VIN3	1 CH	4 CH	9 CH	16 CH	1 CH	4 CH	9 CH	16 CH
0x69				BA				BA			
0x6A				DC				DC			
0x6B				FE				FE			
0x6C				00				00			
0x6D				00				00			
0x6E				88				88			
0x6F				88				88			
0x70				88				88			
0x71				54				54			
0x72				00				00			
0x73				00				00			
0x74				00				00			
0x80	0x90	0xA0	0xB0	00/40/ 80/C0	01/41/ 81/C1	06/46/ 86/C6	0B/4B/ 8B/CB	00/40/ 80/C0	01/41/ 81/C1	06/46/ 86/C6	0B/4B/ 8B/CB
0x81	0x91	0xA1	0xB1	FF	7F	55	3F	FF	7F	55	3F
0x82	0x92	0xA2	0xB2	FF	FF	55	FF	FF	FF	55	FF
0x83	0x93	0xA3	0xB3	FF	7F	55	3F	FF	7F	55	3F
0x84	0x94	0xA4	0xB4	FF	FF	55	FF	FF	FF	55	FF
0x85	0x95	0xA5	0xB5	00	01	06	0B	00	01	06	0B
0x86	0x96	0xA6	0xB6	FF	7F	55	3F	FF	7F	55	3F
0x87	0x97	0xA7	0xB7	FF	FF	55	FF	FF	FF	55	FF
0x88	0x98	0xA8	0xB8	FF	7F	55	3F	FF	7F	55	3F
0x89	0x99	0xA9	0xB9	FF	FF	55	FF	FF	FF	55	FF
0x8A	0x9A	0xAA	0xBA	00/40/ 80/C0	31/71/ B1/F1	-	-	00/40/ 80/C0	31/71/ B1/F1	-	-
0x8B	0x9B	0xAB	0xBB	00				00			
0x8C	0x9C	0xAC	0xBC	D0				D0			
0x8D	0x9D	0xAD	0xBD	00				00			
0x8E	0x9E	0xAE	0xBE	F0				20			
0x8F	0x9F	0xAF	0xBF	08				28			
0xC0				00				00			
0xC1				00				00			
0xC2				00				00			
0xC3				07				07			
0xC4				00				00			
0xC5				00				FF	00	00	00
0xC6				F0				F0			
0xC7				FF				FF			
0xC8				00				00			
0xC9				3C				3C			
0xCA				0F				0F			
0xFE				28				28			

For Video Controller

Address				NTSC				PAL			
CH0	CH1	CH2	CH3	1 CH	4 CH	9 CH	16 CH	1 CH	4 CH	9 CH	16 CH
1x00				8'h00				8'h80			
1x01				00				00			
1x02				00				00			
1x03				00				00			
1x04				00				00			
1x05				80				80			
1x06				00				00			
1x07				00				00			
1x08				00				00			
1x09				00				00			
1x0A				00				00			
1x0B				D7				D7			
1x0C				00				00			
1x0D				00				00			
1x0E				00				00			
1x0F				A7				A7			
1x10				80				80			
1x18				81				81			
1x20				82				82			
1x28				83				83			
1x11	1x19	1x21	1x29	02				02			
1x12	1x1A	1x22	1x2A	00				00			
1x13	1x1B	1x23	1x2B	00				00			
1x14	1x1C	1x24	1x2C	00				00			
1x15	1x1D	1x25	1x2D	00				00			
1x16	1x1E	1x26	1x2E	00				00			
1x17	1x1F	1x27	1x2F	00				00			
1x30				00	00	00	00	00	00	00	00
1x31				B4	5A	3C	2D	B4	5A	3C	2D
1x32				00	00	00	00	00	00	00	00
1x33				78	3C	28	1E	90	48	30	24
1x34				00	5A	3C	2D	00	5A	3C	2D
1x35				B4	B4	78	5A	B4	B4	78	5A
1x36				00	00	00	00	00	00	00	00
1x37				78	3C	28	1E	90	48	30	24
1x38				00	00	78	5A	00	00	78	5A
1x39				B4	5A	B4	87	B4	5A	B4	87
1x3A				00	3C	00	00	00	48	00	00
1x3B				78	78	28	1E	90	90	30	24
1x3C				00	5A	00	87	00	5A	00	87
1x3D				B4	B4	3C	B4	B4	B4	3C	B4
1x3E				00	3C	28	00	00	48	30	00
1x3F				78	78	50	1E	90	90	60	24
1x40 ~ 1x4F				00				00			
1x50				00				00			
1x51				00				00			
1x52				00				00			
1x53				00				00			

Address				NTSC				PAL			
CH0	CH1	CH2	CH3	1 CH	4 CH	9 CH	16 CH	1 CH	4 CH	9 CH	16 CH
1x54				00				00			
1x55				80				80			
1x56				00				00			
1x57				00				00			
1x58				00				00			
1x59				00				00			
1x5A				00				00			
1x5B				00				00			
1x5C				00				00			
1x5D				00				00			
1x5E				00				00			
1x5F				A7				A7			
1x60				80		-	-	80		-	-
1x63				81		-	-	81		-	-
1x66				82		-	-	82		-	-
1x69				83		-	-	83		-	-
1x61	1x64	1x67	1x6A	02		-	-	-		-	-
1x62	1x65	1x68	1x6B	00		-	-	-		-	-
1x6C				00	FF	-	-	00	FF	-	-
1x6D				00	E4	-	-	00	E4	-	-
1x6E				00				00			
1x6F				00				00			
1x70				00				00			
1x71				00				00			
1x72				00				00			
1x73				00				00			
1x74				00				00			
1x75				00				00			
1x76				00				00			
1x77				00				00			
1x78				00				00			
1x79				00				00			
1x7A				00				00			
1x7B				00				00			
1x7C				00				00			
1x7D				00				00			
1x7E				88				88			
1x7F				84				84			
1x80				FF				FF			
1x81				00				00			
1x82				51				51			
1x83				07				07			
1x84				EB				EB			
1x85				10				10			
1x86				A8				A8			
1x87				00				00			
1x88				51				51			
1x89				E7				E7			
1x8A				80				80			

Address				NTSC				PAL			
CH0	CH1	CH2	CH3	1 CH	4 CH	9 CH	16 CH	1 CH	4 CH	9 CH	16 CH
1x8B				00				00			
1x8C				00				00			
1x8D				00				00			
1x8E				00				00			
1x8F				00				00			
1x90 ~ 1x9F				00				00			
1xA0				77				77			
1xA1				23				23			
1xA2				D0				D0			
1xA3				01				01			
1xA4				C0				C0			
1xA5				10				10			
1xA6				00				00			
1xA7				0D				0D			
1xA8				20				20			
1xA9				09				4C			
1xAA				AA				AA			
1xAB				00				00			
1xAC				00				00			
1xAD				00				00			
1xAE				00				00			
1xAF				00				00			
1xB0 ~ 1xBF				00				00			

- Notes 1. Blanks have the same value of 1 CH.
2. All values are Hexa format.

For Motion Detector

Address				NTSC	PAL
VIN0	VIN1	VIN2	VIN3		
2x80	2xA0	2xC0	2xE0	8'h17	8'h17
2x81	2xA1	2xC1	2xE1	88	88
2x82	2xA2	2xC2	2xE2	08	08
2x83	2xA3	2xC3	2xE3	6A	6A
2x84	2xA4	2xC4	2xE4	07	07
2x85	2xA5	2xC5	2xE5	24	24

- Notes 1. All values are Hexa format.

Register Description

VIN	Index	[7]	[6]	[5]	[4]	[3]	[2]	[1]	[0]
0	0x00	DET_ FORMAT			DET_ COLOR	LOCK_ COLOR	LOCK_ GAIN	LOCK_ OFST	LOCK_ HPLL
1	0x10								
2	0x20								
3	0x30								

DET_FORMAT Status of video standard detection (*Read only*)

- 0 PAL-B/D
- 1 PAL-M
- 2 PAL-N
- 3 PAL-60
- 4 NTSC-M
- 5 NTSC-4.43
- 6 NTSC-N

DET_COLOR Status of color detection (*Read only*)

- 0 Color is not detected
- 1 Color is detected

LOCK_COLOR Status of locking for color demodulation loop (*Read only*)

- 0 Color demodulation loop is not locked
- 1 Color demodulation loop is locked

LOCK_GAIN Status of locking for AGC loop (*Read only*)

- 0 AGC loop is not locked
- 1 AGC loop is locked

LOCK_OFST Status of locking for clamping loop (*Read only*)

- 0 Clamping loop is not locked
- 1 Clamping loop is locked

LOCK_HPLL Status of locking for horizontal PLL (*Read only*)

- 0 Horizontal PLL is not locked
- 1 Horizontal PLL is locked

VIN	Index	[7]	[6]	[5]	[4]	[3]	[2]	[1]	[0]
0	0x01	IFMTMAN	IFORMAT			AGC	PEDEST	DET_ NONSTD *	DET_ FLD60 *
1	0x11								
2	0x21								
3	0x31								

Notes : * Read only bits

IFMTMAN	Setting video standard manually with IFORMAT 0 Detect video standard automatically according to incoming video signal (default) 1 Video standard is selected with IFORMAT
IFORMAT	Force the device to operate in a particular video standard when IFMTMAN is high or to free-run in a particular video standard on no-video status when IFMTMAN is low 0 PAL-B/D (default) 1 PAL-M 2 PAL-N 3 PAL-60 4 NTSC-M 5 NTSC-4.43 6 NTSC-N
AGC	Enable the AGC 0 Disable the AGC (default) 1 Enable the AGC
PEDEST	Enable gain correction for 7.5 IRE black (pedestal) level 0 No pedestal level (0 IRE is ITU-R BT.656 code 16) (default) 1 7.5 IRE setup level (7.5 IRE is ITU-R BT.656 code 16)
DET_NONSTD	Status of non-standard video detection (<i>Read only</i>) 0 The incoming video source is standard 1 The incoming video source is non-standard
DET_FLD60	Status of field frequency of incoming video (<i>Read only</i>) 0 50Hz field frequency 1 60Hz field frequency

VIN	Index	[7]	[6]	[5]	[4]	[3]	[2]	[1]	[0]
0	0x06	0	0	/ACTIVE_XY[8]	VDELAY_XY[8]	HACITIVE_XY[9:8]		HDELAY_XY[9:8]	
1	0x16								
2	0x26								
3	0x36								
0	0x02	HDELAY_XY[7:0]							
1	0x12								
2	0x22								
3	0x32								

HDELAY_XY This 10bit register defines the starting location of horizontal active pixel for display / record path. A unit is 1 pixel. The default value is decimal 32.

VIN	Index	[7]	[6]	[5]	[4]	[3]	[2]	[1]	[0]
0	0x06	0	0	/ACTIVE_XY[8]	VDELAY_XY[8]	HACITIVE_XY[9:8]		HDELAY_XY[9:8]	
1	0x16								
2	0x26								
3	0x36								
0	0x03	HACTIVE_XY[7:0]							
1	0x13								
2	0x23								
3	0x33								

HACTIVE_XY This 10bit register defines the number of horizontal active pixel for display / record path. A unit is 1 pixel. The default value is decimal 720.

VIN	Index	[7]	[6]	[5]	[4]	[3]	[2]	[1]	[0]
0	0x06	0	0	VACTIVE_XY[8]	VDELAY_XY[8]	HACITIVE_XY[9:8]		HDELAY_XY[9:8]	
1	0x16								
2	0x26								
3	0x36								
0	0x04	VDELAY_XY[7:0]							
1	0x14								
2	0x24								
3	0x34								

VDELAY_XY This 9bit register defines the starting location of vertical active for display / record path. A unit is 1 line. The default value is decimal 6.

VIN	Index	[7]	[6]	[5]	[4]	[3]	[2]	[1]	[0]
0	0x06	0	0	VACTIVE_XY[8]	VDELAY_XY[8]	HACITIVE_XY[9:8]		HDELAY_XY[9:8]	
1	0x16								
2	0x26								
3	0x36								
0	0x05	VACTIVE_XY[7:0]							
1	0x15								
2	0x25								
3	0x35								

VACTIVE_XY This 9bit register defines the number of vertical active lines for display / record path. A unit is 1 line. The default value is decimal 240.

VIN	Index	[7]	[6]	[5]	[4]	[3]	[2]	[1]	[0]
0	0x07	HUE							
1	0x17								
2	0x27								
3	0x37								

HUE Control the hue information. The resolution is 1.4° / LSB.

0	-180°
:	:
128	0° (default)
:	:
255	180°

VIN	Index	[7]	[6]	[5]	[4]	[3]	[2]	[1]	[0]
0	0x08	SAT							
1	0x18								
2	0x28								
3	0x38								

SAT Control the color saturation. The resolution is 0.8% / LSB.

0	0 %
:	:
128	100 % (default)
:	:
255	200 %

VIN	Index	[7]	[6]	[5]	[4]	[3]	[2]	[1]	[0]
0	0x09	CONT							
1	0x19								
2	0x29								
3	0x39								

CONT Control the contrast. The resolution is 0.8% / LSB.

0	0 %
:	:
128	100 % (default)
:	:
255	200 %

VIN	Index	[7]	[6]	[5]	[4]	[3]	[2]	[1]	[0]
0	0x0A	BRT							
1	0x1A								
2	0x2A								
3	0x3A								

BRT Control the brightness. The resolution is 0.2IRE / LSB.

0	-25 IRE
:	:
128	0 (default)
:	:
255	25 IRE

VIN	Index	[7]	[6]	[5]	[4]	[3]	[2]	[1]	[0]
0	0x0B	YBWI	COMBMD		YPEAK_ MD				YPEAK_GN
1	0x1B								
2	0x2B								
3	0x3B								

YBWI Select the luminance trap filter mode
 0 Narrow bandwidth trap filter mode (default)
 1 Wide bandwidth trap filter mode

COMBMD Select the adaptive comb filter mode
 0,1 Adaptive comb filter mode (default)
 2 Force trap filter mode
 3 Not supported

YPEAK_MD Select the luminance peaking frequency band
 0 4~5 MHz frequency band (default)
 1 2~4 MHz frequency band

YPEAK_GN Control the luminance peaking gain
 0 No peaking (default)
 1 12.5 %
 2 25 %
 3 37.5 %
 4 50 %
 5 62.5 %
 6 75 %
 7 87.5 %
 8 100 %
 9 112.5 %
 10 125 %
 11 137.5 %
 12 150 %
 13 162.5 %
 14 175 %
 15 187.5 %

VIN	Index	[7]	[6]	[5]	[4]	[3]	[2]	[1]	[0]
0	0x0C	0	0	CKILL		CTI_GN			
1	0x1C								
2	0x2C								
3	0x3C								

CKIL Control the color killing mode
 0,1 Auto detection mode (default)
 2 Color is always alive
 3 Color is always killed

CTI_GN Control the CTI gain
 0 No CTI
 1 12.5 %
 2 25 %
 3 37.5 %
 4 50 %
 5 62.5 %
 6 75 % (default)
 7 87.5 %
 8 100 %
 9 112.5 %
 10 125 %
 11 137.5 %
 12 150 %
 13 162.5 %
 14 175 %
 15 187.5 %

VIN	Index	[7]	[6]	[5]	[4]	[3]	[2]	[1]	[0]
0	0x0D	0	0	0	0	ANA_SW	SW_RESET	WPEAK_MD	
1	0x1D								
2	0x2D								
3	0x3D								

ANA_SW

Control the analog input channel switch

0 VIN_A channel is selected (default)

1 VIN_B channel is selected

SW_RESET

Reset the system by software except control registers.

This bit is self-clearing in a few clocks after enabled.

0 Normal operation (default)

1 Enable soft reset

WPEAK_MD

Select the automatic white peak control mode.

0 No automatic white peak control (default)

1 Suppress the excessive white peak level into WPEAK_REF level

2 Increase the low level into WPEAK_REF level

3 Suppress and Increase the input level into WPEAK_REF level

VIN	Index	[7]	[6]	[5]	[4]	[3]	[2]	[1]	[0]
0	0x0E	0	0	0	1	0	0	0	1
1	0x1E								
2	0x2E								
3	0x3E								

This control register is reserved for putting the part into test mode. For normal operation, the above value should be set in this register.

Index	[7]	[6]	[5]	[4]	[3]	[2]	[1]	[0]
0x40	PB_SDEL		WPEAK_REF		WPEAK_RNG		WPEAK_TIME	

PB_SDEL Control the start point of active video from ITU-R BT.656 digital playback input

- 0 No delay (default)
- 1 1ck delay of 27MHz
- 2 2ck delay of 27MHz
- 3 3ck delay of 27MHz

WPEAK_REF Control the white peak reference level for automatic white peak control

- 0 100 IRE (default)
- 1 110 IRE
- 2 130 IRE
- 3 140 IRE

WPEAK_RNG Control the range of automatic white peak control

- 0 -3 ~ 3 dB (default)
- 1 -6 ~ 6 dB
- 2,3 -9 ~ 9 dB

WPEAK_TIME Control the time constant of automatic white peak control loop

- 0 Slower (default)
- 1 Slow
- 2 Fast
- 3 Faster

Index	[7]	[6]	[5]	[4]	[3]	[2]	[1]	[0]
0x41	MPPCLK_OEB	VOGAINCX			0	VOGAINYX		
0x42	0	0	0	0	0	VOGAINYY		

MPPCLK_OEB Control the tri-state of CLKMPP1/2 output pins
 0 Outputs are Tri-state (default)
 1 Outputs are enabled

VOGAIN Control the gain of analog video output for each DAC
 0 90.625 %
 1 93.75 %
 2 96.875 %
 3 100 %
 4 103.125 %
 5 106.25 %
 6 109.375 %
 7 112.5 %

Index	[7]	[6]	[5]	[4]	[3]	[2]	[1]	[0]
0x43	0	1	0	0	GNTIME		OSTIME	

GNTIME Control the time constant of gain tracking loop

- 0 Slower
- 1 Slow (default)
- 2 Fast
- 3 Faster

OSTIME Control the time constant of offset tracking loop

- 0 Slower
- 1 Slow (default)
- 2 Fast
- 3 Faster

Index	[7]	[6]	[5]	[4]	[3]	[2]	[1]	[0]
0x44	1	0	HSWIDTH					

HSWIDTH Define the width of horizontal sync output.
A unit is 1 pixel. The default value is decimal 32.

Index	[7]	[6]	[5]	[4]	[3]	[2]	[1]	[0]
0x45	FLDMODE		VSMODE	FLDPOL	HSPOL	VSPOL	1	0

FLDMODE Select the field flag generation mode
 0 Field flag is detected from incoming video (default)
 1 Field flag is generated from small accumulator of detected field
 2 Field flag is generated from medium accumulator of detected field
 3 Field flag is generated from large accumulator of detected field

VSMODE Control the VS and field flag timing
 0 VS and field flag is aligned with vertical sync of incoming video (default)
 1 VS and field flag is aligned with HS

FLDPOL Select the FLD polarity
 0 Odd field is high (default)
 1 Even field is high

HSPOL Select the HS polarity
 0 Low for sync duration (default)
 1 High for sync duration

VSPOL Select the VS polarity
 0 Low for sync duration (default)
 1 High for sync duration

Index	[7]	[6]	[5]	[4]	[3]	[2]	[1]	[0]
0x46	IFCOMP		CLPF		ACCTIME		APCTIME	

IFCOMP Select the IF-compensation filter mode

- 0 No compensation (default)
- 1 +1 dB/ MHz
- 2 +2 dB/ MHz
- 3 +3 dB/ MHz

CLPF Select the Color LPF mode

- 0 550KHz bandwidth
- 1 750KHz bandwidth (default)
- 2 950KHz bandwidth
- 3 1.1MHz bandwidth

ACCTIME Control the time constant of auto color control loop

- 0 Slower
- 1 Slow
- 2 Fast
- 3 Faster (default)

APCTIME Control the time constant of auto phase control loop

- 0 Slower
- 1 Slow
- 2 Fast
- 3 Faster (default)

Index	[7]	[6]	[5]	[4]	[3]	[2]	[1]	[0]
0x47	0	1	C_CORE		0	CDEL		

- C_CORE Coring to reduce the noise in the chrominance
- 0 No coring
 - 1 Coring value is within 128 +/- 1 range
 - 2 Coring value is within 128 +/- 2 range (default)
 - 3 Coring value is within 128 +/- 4 range

- CDEL Adjust the group delay of chrominance path relative to luminance
- 0 -2.0 pixel
 - 1 -1.5 pixel
 - 2 -1.0 pixel
 - 3 -0.5 pixel
 - 4 0.0 pixel (default)
 - 5 0.5 pixel
 - 6 1.0 pixel
 - 7 1.5 pixel

Index	[7]	[6]	[5]	[4]	[3]	[2]	[1]	[0]
0x48	U_GAIN							

U_GAIN Adjust gain for U (or Cb) component. The resolution is 0.8% / LSB.

0	0 %
:	:
128	100 % (default)
:	:
255	200 %

Index	[7]	[6]	[5]	[4]	[3]	[2]	[1]	[0]
0x49	V_GAIN							

V_GAIN Adjust gain for V (or Cr) component. The resolution is 0.8% / LSB.

0	0 %
:	:
128	100 % (default)
:	:
255	200 %

Index	[7]	[6]	[5]	[4]	[3]	[2]	[1]	[0]
0x4A	U_OFF							

U_OFF U (or Cb) offset adjustment register. The resolution is 0.4% / LSB.
 0 -50 %
 : :
 128 0 % (default)
 : :
 255 50 %

Index	[7]	[6]	[5]	[4]	[3]	[2]	[1]	[0]
0x4B	V_OFF							

V_OFF V (or Cr) offset adjustment register. The resolution is 0.4% / LSB.
 0 -50 %
 : :
 128 0 % (default)
 : :
 255 50 %

Index	[7]	[6]	[5]	[4]	[3]	[2]	[1]	[0]
0x4C	0	0	ADAC_ PD	AADC_ PD	VADC_PD			

ADAC_PD Power down the audio DAC.
 0 Normal operation (default)
 1 Power down

AADC_PD Power down the audio ADC.
 0 Normal operation (default)
 1 Power down

VADC_PD Power down the video ADC.
 VADC_PD[3:0] stands for CH3 to CH0.
 0 Normal operation (default)
 1 Power down

Index	[7]	[6]	[5]	[4]	[3]	[2]	[1]	[0]
0x4D	0	0	0	0	NOVID_MD		1	1

NOVID_MD Select the No-video flag generation mode
 0 Faster
 1 Fast
 2 Slow
 3 Slower (default)

Index	[7]	[6]	[5]	[4]	[3]	[2]	[1]	[0]
0x4E	0	0	0	0	0	1	0	1
0x4F	0	0	0	0	0	0	0	0
0x50	0	0	0	0	0	0	0	0
0x51	1	0	0	0	0	0	0	0
0x52	0	0	0	0	0	1	1	0
0x53	0	0	0	0	0	0	0	0
0x54	0	0	0	0	0	0	0	0

This control register is reserved for putting the part into test mode. For normal operation, the above value should be set in this register.

Index	[7]	[6]	[5]	[4]	[3]	[2]	[1]	[0]
0x55	FLD				VAV			

FLD Status of the field flag for corresponding channel (*Read only*)

FLD[3:0] stands for VIN3 to VIN0.

0 Odd field when FLDPOL (0x46) = 1

1 Even field when FLDPOL (0x46) = 1

VAV Status of the vertical active video signal for corresponding channel (*Read only*). VAV[3:0] stands for VIN3 to VIN0.

0 Vertical blanking time

1 Vertical active time

Index	[7]	[6]	[5]	[4]	[3]	[2]	[1]	[0]
0x60	AIGAIN1				AIGAIN0			
0x61	AIGAIN3				AIGAIN2			

AIGAIN

Select the amplifier's gain for each analog audio input AIN0 ~ AIN3.

- 0 0.25
- 1 0.31
- 2 0.38
- 3 0.44
- 4 0.50
- 5 0.63
- 6 0.75
- 7 0.88
- 8 1.00 (default)
- 9 1.25
- 10 1.50
- 11 1.75
- 12 2.00
- 13 2.25
- 14 2.50
- 15 2.75

Index	[7]	[6]	[5]	[4]	[3]	[2]	[1]	[0]
0x62	M_PBSEL		M_RLSWAP	RM_BITRATE	RM_DATMOD	RM_SAMRATE	RM_BITWID	RM_SYNC

M_PBSEL	Select the playback audio data on the ADATM / AOUT pin. 0 The playback audio input from the first stage chip (default) 1 The playback audio input from the second stage chip 2 The playback audio input from the third stage chip 3 The playback audio input from the last stage chip
M_RLSWAP	Define the sequence of mixing and playback audio data on the ADATM pin. 0 Mixing audio on left channel and playback audio on right channel (default) 1 Playback audio on left channel and mixing audio on right channel
RM_BITRATE	Define the bit rate for record and mixing audio on the ACLKR, ASYNR, ADATR and ADATM pin. 0 256 bit per sample period (256fs) (default) 1 384 bit per sample period (384fs)
RM_DATMOD	Define the data mode on the ADATR and ADATM pin. 0 2's complement data mode (default) 1 Straight binary data mode
RM_SAMRATE	Define the sample rate for record and mixing audio on the ACLKR, ASYNR, ADATR and ADATM pin. 0 8KHz (default) 1 16KHz
RM_BITWID	Define the bit width for record and mixing audio on the ADATR and ADATM pin. 0 16 bit (default) 1 8 bit
RM_SYNC	Define the digital serial audio data format for record and mixing audio on the ACLKR, ASYNR, ADATR and ADATM pin. 0 I2S format (default) 1 DSP format

Index	[7]	[6]	[5]	[4]	[3]	[2]	[1]	[0]
0x63	0	0	0	0	0	R_ADATM	R_MULTCH	

R_ADATM Select the output mode for the ADATM pin.
 0 Digital serial data of mixing audio (default)
 1 Digital serial data of record audio

R_MULTCH Define the number of audio for record on the ADATR pin.
 0 2 audios (default)
 1 4 audios
 2 8 audios
 3 16 audios

Index	[7]	[6]	[5]	[4]	[3]	[2]	[1]	[0]
0x64	R_SEQ_1				R_SEQ_0			
0x65	R_SEQ_3				R_SEQ_2			
0x66	R_SEQ_5				R_SEQ_4			
0x67	R_SEQ_7				R_SEQ_6			
0x68	R_SEQ_9				R_SEQ_8			
0x69	R_SEQ_B				R_SEQ_A			
0x6A	R_SEQ_D				R_SEQ_C			
0x6B	R_SEQ_F				R_SEQ_E			

R_SEQ

Define the sequence of record audio on the ADATR pin.

Refer to the Fig16 and Table5 for the detail of the R_SEQ_0 ~ R_SEQ_F.

The default value of R_SEQ_0 is "0", R_SEQ_1 is "1", ... and R_SEQ_F is "F".

- 0 AIN1
- 1 AIN2
- : :
- : :
- 14 AIN15
- 15 AIN16

Index	[7]	[6]	[5]	[4]	[3]	[2]	[1]	[0]
0x6C	0	PB_MASTER	PB_LRSEL	PB_BITRATE	PB_DATMOD	PB_SAMRATE	PB_BITWID	PB_SYNC

PB_MASTER	Define the operation mode of the ACLKP and ASYNP pin for playback. 0 Slaver mode (ACLKP and ASYNP is input mode) (default) 1 Master mode (ACLKP and ASYNP is output mode)
PB_LRSEL	Select the channel for playback. 0 Left channel audio is used for playback input. (default) 1 Right channel audio is used for playback input.
PB_BITRATE	Define the bit rate for playback audio on the ACLKP, ASYNP and ADATP pin. 0 256 bit per sample period (256fs) (default) 1 384 bit per sample period (384fs)
PB_DATMOD	Define the data mode on the ADATP pin. 0 2's complement data mode (default) 1 Straight binary data mode
PB_SAMRATE	Define the sample rate for playback audio on the ACLKP, ASYNP and ADATP pin. 0 8KHz (default) 1 16KHz
PB_BITWID	Define the bit width for playback audio on the ADATP pin. 0 16 bit (default) 1 8 bit
PB_SYNC	Define the digital serial audio data format for playback audio on the ACLKP, ASYNP and ADATP pin. 0 I2S format (default) 1 DSP format

Index	[7]	[6]	[5]	[4]	[3]	[2]	[1]	[0]
0x6D	0	0	MIX_ DERATIO	MIX_MUTE				

MIX_DERATIO Disable the mixing ratio value for all audio.
 0 Apply individual mixing ratio value for each audio (default)
 1 Apply nominal value for all audio commonly

MIX_MUTE Enable the mute function for each audio. It effects only for mixing.
 MIX_MUTE[0] : Audio input AIN0.
 MIX_MUTE[1] : Audio input AIN1.
 MIX_MUTE[2] : Audio input AIN2.
 MIX_MUTE[3] : Audio input AIN3.
 MIX_MUTE[4] : Playback audio input.
 It effects only for single chip or the last stage chip
 0 Normal
 1 Muted (default)

Index	[7]	[6]	[5]	[4]	[3]	[2]	[1]	[0]
0x6E	MIX_RATIO1				MIX_RATIO0			
0x6F	MIX_RATIO3				MIX_RATIO2			
0x70	AOGAIN				MIX_RATIO_P			

MIX_RATIO

Define the ratio values for audio mixing.

MIX_RATIO0 : Audio input AIN0.

MIX_RATIO1 : Audio input AIN1.

MIX_RATIO2 : Audio input AIN2.

MIX_RATIO3 : Audio input AIN3.

MIX_RATIO_P : Playback audio input.

It effects only for single chip or the last stage chip.

- 0 0.25
- 1 0.31
- 2 0.38
- 3 0.44
- 4 0.50
- 5 0.63
- 6 0.75
- 7 0.88
- 8 1.00 (default)
- 9 1.25
- 10 1.50
- 11 1.75
- 12 2.00
- 13 2.25
- 14 2.50
- 15 2.75

Index	[7]	[6]	[5]	[4]	[3]	[2]	[1]	[0]
0x70	AOGAIN				MIX_RATIO			

AOGAIN Define the amplifier gain for analog audio output.

- 0 0.25
- 1 0.31
- 2 0.38
- 3 0.44
- 4 0.50
- 5 0.63
- 6 0.75
- 7 0.88
- 8 1.00 (default)
- 9 1.25
- 10 1.50
- 11 1.75
- 12 2.00
- 13 2.25
- 14 2.50
- 15 2.75

Index	[7]	[6]	[5]	[4]	[3]	[2]	[1]	[0]
0x71	0	1	MIX_MODE	MIX_OUTSEL				

MIX_MODE Control the mixing mode for audio mixing.

- 0 Average mode (default)
- 1 Just summation mode

MIX_OUTSEL Define the final audio output for analog and digital mixing out.

- 0 Select record audio of channel 0
- 1 Select record audio of channel 1
- 2 Select record audio of channel 2
- 3 Select record audio of channel 3
- 4 Select record audio of channel 4
- 5 Select record audio of channel 5
- 6 Select record audio of channel 6
- 7 Select record audio of channel 7
- 8 Select record audio of channel 8
- 9 Select record audio of channel 9
- 10 Select record audio of channel 10
- 11 Select record audio of channel 11
- 12 Select record audio of channel 12
- 13 Select record audio of channel 13
- 14 Select record audio of channel 14
- 15 Select record audio of channel 15
- 16 Select playback audio of the first stage chip
- 17 Select playback audio of the second stage chip
- 18 Select playback audio of the third stage chip
- 19 Select playback audio of the last stage chip
- 20 Select mixed audio (default)

Index	[7]	[6]	[5]	[4]	[3]	[2]	[1]	[0]
0x72	0	0	0	0	0	0	0	0
0x73	0	0	0	0	0	0	0	0
0x74	0	0	0	0	0	0	0	0

This control register is reserved for putting the part into test mode. For normal operation, the above value should be set in this register.

CH	Index	[7]	[6]	[5]	[4]	[3]	[2]	[1]	[0]
0	0x80	DEC_PATH_X	0	0	VSFLT_X	HSFLT_X			
1	0x90								
2	0xA0								
3	0xB0								

DEC_PATH_X Select the video input for each channel scaler in display path.

- 0 Video input from internal video decoder on VIN0 pin (default)
- 1 Video input from internal video decoder on VIN1 pin
- 2 Video input from internal video decoder on VIN2 pin
- 3 Video input from internal video decoder on VIN3 pin

VSFLT_X Select the vertical anti-aliasing filter mode for display path.

- 0 Full bandwidth (default)
- 1 0.25 Line-rate bandwidth
- 2,3 0.18 Line-rate bandwidth

HSFLT_X Select the horizontal anti-aliasing filter mode for display path.

- 0 Full bandwidth (default)
- 1 2 MHz bandwidth
- 2 1.5 MHz bandwidth
- 3 1 MHz bandwidth

Path	CH	Index	[7]	[6]	[5]	[4]	[3]	[2]	[1]	[0]
X	0	0x81	VSCALE_X[15:8]							
	1	0x91								
	2	0xA1								
	3	0xB1								
	0	0x82	VSCALE_X[7:0]							
	1	0x92								
	2	0xA2								
	3	0xB2								
PB	0	0x86	VSCALE_PB[15:8]							
	1	0x96								
	2	0xA6								
	3	0xB6								
	0	0x87	VSCALE_PB[7:0]							
	1	0x97								
	2	0xA7								
	3	0xB7								

VSCALE The 16 bit register defines a vertical scaling ratio. The actual vertical scaling ratio is $VSCALE/(2^{16} - 1)$. The default value is 0xFFFF.

Path	CH	Index	[7]	[6]	[5]	[4]	[3]	[2]	[1]	[0]
X	0	0x83	HSCALE_X[15:8]							
	1	0x93								
	2	0xA3								
	3	0xB3								
	0	0x84	HSCALE_X[7:0]							
	1	0x94								
	2	0xA4								
	3	0xB4								
PB	0	0x88	HSCALE_PB[15:8]							
	1	0x98								
	2	0xA8								
	3	0xB8								
	0	0x89	HSCALE_PB[7:0]							
	1	0x99								
	2	0xA9								
	3	0xB9								

HSCALE The 16 bit register defines a horizontal scaling ratio. The actual horizontal scaling ratio is $HSCALE/(2^{16} - 1)$. The default value is 0xFFFF.

CH	Index	[7]	[6]	[5]	[4]	[3]	[2]	[1]	[0]
0	0x85	0	0	0	0	VSFLT_PB		HSFLT_PB	
1	0x95								
2	0xA5								
3	0xB5								

VSFLT_PB Select the vertical anti-aliasing filter mode for PB path.

- 0 Full bandwidth (default)
- 1 0.25 Line-rate bandwidth
- 2,3 0.18 Line-rate bandwidth

HSFLT_PB Select the horizontal anti-aliasing filter mode for PB path.

- 0 Full bandwidth (default)
- 1 2 MHz bandwidth
- 2 1.5 MHz bandwidth
- 3 1 MHz bandwidth

CH	Index	[7]	[6]	[5]	[4]	[3]	[2]	[1]	[0]
0	0x8A	0		VSCALE_ Y	HSCALE_ Y	VSFLT_Y		HSFLT_Y	
1	0x9A	1							
2	0xAA	2							
3	0xBA	3							

VSCALE_Y Enable the half vertical scaling for record path.
 0 Disable the vertical scaling (default)
 1 Enable the half vertical scaling

HSCALE_Y Enable the half horizontal scaling for record path.
 0 Disable the horizontal scaling (default)
 1 Enable the half horizontal scaling

VSFLT_PB Select the vertical anti-aliasing filter mode for record path.
 0 Full bandwidth (default)
 1 0.25 Line-rate bandwidth
 2,3 0.18 Line-rate bandwidth

HSFLT_PB Select the horizontal anti-aliasing filter mode for record path.
 0 Full bandwidth (default)
 1 2 MHz bandwidth
 2 1.5 MHz bandwidth
 3 1 MHz bandwidth

CH	Index	[7]	[6]	[5]	[4]	[3]	[2]	[1]	[0]
0	0x06	0	0	/ACTIVE_ PB[8]	VDELAY_ PB[8]	HACITIVE_PB[9:8]		HDELAY_PB[9:8]	
1	0x16								
2	0x26								
3	0x36								
0	0x02	HDELAY_PB[7:0]							
1	0x12								
2	0x22								
3	0x32								

HDELAY_PB This 10bit register defines the starting location of horizontal active pixel for PB path. A unit is 1 pixel. The default value is decimal 0.

CH	Index	[7]	[6]	[5]	[4]	[3]	[2]	[1]	[0]
0	0x06	0	0	/ACTIVE_ PB[8]	VDELAY_ PB[8]	HACITIVE_PB[9:8]		HDELAY_PB[9:8]	
1	0x16								
2	0x26								
3	0x36								
0	0x03	HACTIVE_PB[7:0]							
1	0x13								
2	0x23								
3	0x33								

HACTIVE_PB This 10bit register defines the number of horizontal active pixel for PB path. A unit is 1 pixel. The default value is decimal 720.

CH	Index	[7]	[6]	[5]	[4]	[3]	[2]	[1]	[0]
0	0x06	0	0	VACTIVE_PB[8]	VDELAY_PB[8]	HACITIVE_PB[9:8]		HDELAY_PB[9:8]	
1	0x16								
2	0x26								
3	0x36								
0	0x04	VDELAY_PB[7:0]							
1	0x14								
2	0x24								
3	0x34								

VDELAY_PB This 9bit register defines the starting location of vertical active for PB path. A unit is 1 line. The default value is decimal 0.

CH	Index	[7]	[6]	[5]	[4]	[3]	[2]	[1]	[0]
0	0x06	0	0	VACTIVE_PB[8]	VDELAY_PB[8]	HACITIVE_PB[9:8]		HDELAY_PB[9:8]	
1	0x16								
2	0x26								
3	0x36								
0	0x05	VACTIVE_PB[7:0]							
1	0x15								
2	0x25								
3	0x35								

VACTIVE_PB This 9bit register defines the number of vertical active lines for PB path. A unit is 1 line. The default value is decimal 240.

Index	[7]	[6]	[5]	[4]	[3]	[2]	[1]	[0]
0xC0	0	PB_FLDPOL	0	0	MAN_PBCROP	PB_CROP_MD	PB_ACT_MD	

PB_FLDPOL Select the FLD polarity of playback input
 0 Even field is high
 1 Odd field is high

MAN_PB_CROP Select manual cropping mode for playback input
 0 Auto cropping mode with fixed cropping position (default)
 1 Manual cropping mode with HDELAY/HACTIVE and
 VDELAY/VACTIVE

PB_CROP_MD Select the cropping mode for playback input
 0 Normal record mode or frame record mode (default)
 1 Cropping for DVR record mode or DVR frame record mode input

PB_ACT_MD Select the horizontal active size for playback input when MAN_PB_CROP
 is low
 0 720 pixels (default)
 1 704 pixels
 2/3 640 pixels

Index	[7]	[6]	[5]	[4]	[3]	[2]	[1]	[0]
0xC1	LIM_656_ PB	LIM_656_ X	LIM_656_Y1		LIM_656_Y0			
0xC2	0	LIM_656_ DEC	LIM_656_Y3		LIM_656_Y2			

LMT_656_PB Control the range of output level for PB path.
 0 Output ranges are limited to 1 ~ 254 (default)
 1 Output ranges are limited to 16 ~ 235

LMT_656_X Control the range of output level for display path.
 0 Output ranges are limited to 1 ~ 254 (default)
 1 Output ranges are limited to 16 ~ 235

LMT_656_Y Control the range of output level for record path.
 0 Output ranges are limited to 1 ~ 254 (default)
 1 Output ranges are limited to 16 ~ 254
 2 Output ranges are limited to 24 ~ 254
 3 Output ranges are limited to 32 ~ 254
 4 Output ranges are limited to 1 ~ 235
 5 Output ranges are limited to 16 ~ 235
 6 Output ranges are limited to 24 ~ 235
 7 Output ranges are limited to 32 ~ 235

LMT_656_DEC Control the range of output level for decoder bypass mode.
 0 Output ranges are limited to 1 ~ 254 (default)
 1 Output ranges are limited to 16 ~ 235

Index	[7]	[6]	[5]	[4]	[3]	[2]	[1]	[0]
0xC3	BGNDEN_PB				BGNDCOL	AUTO BGNDPB	AUTO BGNDY	AUTO BGNDX
0xC4	BGNDEN_Y				BGNDEN_X			

BGNDEN Enable the background color for each channel.

BGNDEN[3:0] stands for CH3 to CH0.

- 0 Background color is disabled (default)
- 1 Background color is enabled

BLKCOL Select the background color when BGNDEN = "1".

- 0 Blue color (default)
- 1 Black color

AUTO_BGND Select the decoder background mode.

- 0 Manual background mode (default)
- 1 Automatic background mode when No-video is detected.

Index	[7]	[6]	[5]	[4]	[3]	[2]	[1]	[0]
0xC5	PAL_DLY_Y				PAL_DLY_X			
0xC6	1	1	1	1	PAL_DLY_PB			

PAL_DLY Select the PAL delay line mode.

0 Vertical scaling mode is selected in chrominance path (default)

1 PAL delay line mode is selected in chrominance path

Index	[7]	[6]	[5]	[4]	[3]	[2]	[1]	[0]
0xC7	1	1	1	1	1	1	1	1

This control register is reserved for putting the part into test mode. For normal operation, the above value should be set in this register.

Index	[7]	[6]	[5]	[4]	[3]	[2]	[1]	[0]
0xC8	0	0	0	0	0	FLD_ OFST_PB	FLD_ OFST_Y	FLD_ OFST_X

FLDOS Remove the field offset between ODD and EVEN field.

0 Normal operation (default)

1 Remove the field offset between ODD and EVEN field

Index	[7]	[6]	[5]	[4]	[3]	[2]	[1]	[0]
0xC9	0	0	1	1	1	1	0	0

This control register is reserved for putting the part into test mode. For normal operation, the above value should be set in this register.

Index	[7]	[6]	[5]	[4]	[3]	[2]	[1]	[0]
0xCA	0	OUT_CHID	0	0	1	1	1	1

OUT_CHID Enable the channel ID format in the horizontal blanking period for Decoder Bypass mode
 0 Disable the channel ID format (default)
 1 Enable the channel ID format

Index	[7]	[6]	[5]	[4]	[3]	[2]	[1]	[0]
0xFE	DEV_ID *					REV_ID *		

Notes “*” stand for read only register

DEV_ID The TW2835 product ID code is 00101.

REV_ID The revision number.

Index	[7]	[6]	[5]	[4]	[3]	[2]	[1]	[0]
1x00	SYS_5060	OVERLAY	LINK_LAST_X	LINK_LAST_Y	LINK_EN_X	LINK_EN_Y	LINK_NUM	

- SYS_5060** Select the standard format for video controller.
 0 60Hz, 525 line format (default)
 1 50Hz, 625 line format
- OVERLAY** Control the overlay between display and record path.
 0 Disable the overlay (default)
 1 Enable the overlay
- LINK_LAST** Define the lowest slaver chip in chip-to-chip cascade operation.
 0 Master or middle slaver chip (default)
 1 The lowest slaver chip
- LINK_EN** Control the chip-to-chip cascade operation for display and record path.
 0 Disable the cascade operation (default)
 1 Enable the cascade operation
- LINK_NUM** Define the stage number of chip-to-chip cascade connection.
 0 Master chip (default)
 1 1st slaver chip
 2 2nd slaver chip
 3 3rd slaver chip

Path	Index	[7]	[6]	[5]	[4]	[3]	[2]	[1]	[0]
X	1x01	0	0	0	TBLINK	FRZ_FRAME	DUAL_PAGE	STRB_FLD	

- TBLINK** Control the blink period of channel boundary.
- 0 Blink for every 30 fields (default)
 - 1 Blink for every 60 fields
- FRZ_FRAME** Select the field or frame mode on freeze status.
- 0 Field display mode (default)
 - 1 Frame display mode
- DUAL_PAGE** Enable the dual page operation.
- 0 Normal strobe operation for each channel (default)
 - 1 Enable the dual page operation
- STRB_FLD** Control the field mode for strobe operation.
- 0 Capture odd field only (default)
 - 1 Capture even field only
 - 2 Capture first field of any field
 - 3 Capture frame

Path	Index	[7]	[6]	[5]	[4]	[3]	[2]	[1]	[0]
X	1x02	RECALL_FLD	SAVE_FLD	SAVE_HID	SAVE_ADDR				

- RECALL_FLD** Select the field or frame data on recalling picture.
- 0 Recall frame data from SDRAM (default)
 - 1 Recall field data from SDRAM
- SAVE_FLD** Select the field or frame data to save.
- 0 Save first odd field data to SDRAM (default)
 - 1 Save first even field data to SDRAM
 - 2 Save first any field data to SDRAM
 - 3 Save first frame (odd and even field) data to SDRAM
- SAVE_HID** Control the priority to save picture.
- 0 Save picture as shown in screen (default)
 - 1 Save picture even though hidden under other picture
- SAVE_ADDR** Define the save address of SDRAM.
- The unit address has 4Mbit memory space.
- 0-3 Reserved for normal operation. Do not use this address.
(default = 0)
 - 4-11 Available address for 64M SDRAM
 - 12-15 Reserved for normal operation. Do not use this address.

Path	Index	[7]	[6]	[5]	[4]	[3]	[2]	[1]	[0]
X	1x03	SAVE_REQ							

- SAVE_REQ** Request to save for each channel.
- SAVE_REQ[7:0] stands for channel 7 to 0
- 0 None operation (default)
 - 1 Request to start saving picture

Path	Index	[7]	[6]	[5]	[4]	[3]	[2]	[1]	[0]
X	1x04	STRB_REQ							

STRB_REQ Request strobe operation.
 STRB_REQ[7:0] stands for channel 7 to 0
 0 None operation (default)
 1 Request to start strobe operation

Path	Index	[7]	[6]	[5]	[4]	[3]	[2]	[1]	[0]
X	1x05	NOVID_MODE	0	0	0	AUTO_ENHANCE	INVALID_MODE		

NOVID_MODE Select the indication method for no-video channel
 0 Bypass (default)
 1 Capture last image
 2 Blanked with blank color
 3 Capture last image and blink channel boundary

AUTO_ENHANCE Enable auto enhancement mode in field display mode
 0 Manual enhancement mode in field display mode (default)
 1 Auto enhancement mode in field display mode

INVALID_MODE Select the indication mode for no channel area
 In horizontal and vertical active region
 0 Background layer with background color (default)
 1 Y = 0, Cb/Cr = 128
 2 Y/Cb/Cr = 0
 3 Y/Cb/Cr = 0

In horizontal and vertical blanking region
 0 Y = 16, Cb/Cr = 128 (default)
 1 Background layer with background color
 2 Y = 0, Cb = {0, F, V, 0, Cascade, linenum[8:7]}, Cr = {0, linenum[6:0]}
 3 Y/Cb/Cr = 0

Path	Index	[7]	[6]	[5]	[4]	[3]	[2]	[1]	[0]
X	1x06	MUX_MODE	0	MUX_FLD		0	0	0	0

MUX_MODE Define the switch operation mode
 0 Switch still mode (default)
 1 Switch live mode

MUX_FLD Select the field mode on switch still mode
 0 Odd Field (default)
 1 Even Field
 2,3 Capture Frame

Path	Index	[7]	[6]	[5]	[4]	[3]	[2]	[1]	[0]
X	1x07	STRB_AUTO	0	0	NTR_REQX	INTR_CH			

STRB_AUTO Enable automatic strobe mode when FUNC_MODE = "1"
 0 User strobe mode (default)
 1 Automatic strobe mode

INTR_REQX Request to start the interrupt switch operation in display path
 0 None operation (default)
 1 Request to start the interrupt switch operation in display path

INTR_CH Define the channel number for interrupt switch operation
 INTR_CH[3:2] represents the stage of cascaded chips for interrupt switch operation
 0 Master chip (default)
 1 1st slaver chip
 2 2nd slaver chip
 3 3rd slaver chip

 INTR_CH[1:0] represents the channel number for interrupt switch operation
 0 Channel 0 (default)
 1 Channel 1
 2 Channel 2
 3 Channel 3

Path	Index	[7]	[6]	[5]	[4]	[3]	[2]	[1]	[0]
X	1x08	MUX_OUT_CH0 *				MUX_OUT_CH1 *			
	1x09	MUX_OUT_CH2 *				MUX_OUT_CH3 *			

Notes “*” stand for read only register

- MUX_OUT_CH0 Channel information in current field/frame for interrupt switch operation
 - MUX_OUT_CH1 Channel information in next field/frame for interrupt switch operation
 - MUX_OUT_CH2 Channel information after 2 fields for interrupt switch operation
 - MUX_OUT_CH3 Channel information after 3 fields for interrupt switch operation
- MUX_OUT_CH [3:2] represents the stage of cascaded chips for interrupt switch operation
- 0 Master chip (default)
 - 1 1st slaver chip
 - 2 2nd slaver chip
 - 3 3rd slaver chip
- MUX_OUT_CH [1:0] represents the channel number for interrupt switch operation
- 0 Channel 0 (default)
 - 1 Channel 1
 - 2 Channel 2
 - 3 Channel 3

Path	Index	[7]	[6]	[5]	[4]	[3]	[2]	[1]	[0]
X	1x0A	CHID_MUX_OUT *							

Notes “*” stand for read only register

- CHID_MUX_OUT Channel ID of current field/frame in interrupt switch operation
 CHID_MUX_OUT [7] represents the channel ID latch enabling pulse
 0->1 Rising edge for channel ID Update
 1->0 Falling edge after 16 clock * 18.5 ns from rising edge
- CHID_MUX_OUT [6] represents the updated picture in interrupt switch operation
 0 No Updated
 1 Updated by new switching
- CHID_MUX_OUT [5] represents the field mode in interrupt switch operation
 0 Frame Mode
 1 Field Mode
- CHID_MUX_OUT [4] represents the analog switch path
 0 Analog switch 0 path
 1 Analog switch 1 path
- CHID_MUX_OUT [3:2] represents the stage of cascaded chips for interrupt switch operation
 0 Master chip
 1 1st slaver chip
 2 2nd slaver chip
 3 3rd slaver chip
- CHID_MUX_OUT [1:0] represents the channel number for interrupt switch operation
 0 Channel 0
 1 Channel 1
 2 Channel 2
 3 Channel 3

Path	Index	[7]	[6]	[5]	[4]	[3]	[2]	[1]	[0]
X	1x0B	ZM_EVEN_OS		ZM_ODD_OS		FR_EVEN_OS		FR_ODD_OS	

ZM_EVEN_OS Even field offset coefficient when zoom is enabled

- 0 No Offset
- 1 + 0.25 Offset
- 2 + 0.5 Offset
- 3 + 0.75 Offset (default)

ZM_ODD_OS Odd field offset coefficient when zoom is enabled

- 0 No Offset
- 1 + 0.25 Offset (default)
- 2 + 0.5 Offset
- 3 + 0.75 Offset

FR_EVEN_OS Even field offset coefficient when the enhancement is enabled

- 0 No Offset
- 1 + 0.25 Offset (default)
- 2 + 0.5 Offset
- 3 + 0.75 Offset

FR_ODD_OS Odd field offset coefficient when the enhancement is enabled

- 0 No Offset
- 1 + 0.25 Offset
- 2 + 0.5 Offset
- 3 + 0.75 Offset (default)

Path	Index	[7]	[6]	[5]	[4]	[3]	[2]	[1]	[0]
X	1x0C	ZMENA	H_ZM_MD	ZMBNDCOL		ZMBNDEN	ZMAREAEN	ZMAREA	

ZMENA	Enable the zoom function.
0	Disable the zoom function (default)
1	Enable the zoom function
H_ZM_MD	Select the zoom mode for only horizontal direction
0	2x zoom for both horizontal and vertical direction (default)
1	2x zoom for horizontal direction
ZMBNDCOL	Define the boundary color for zoomed area
0	0% Black (default)
1	25% Gray
2	75% Gray
3	100% White
ZMBNDEN	Enable the boundary for zoomed area.
0	Disable the boundary for zoomed area (default)
1	Enable the boundary for zoomed area
ZMAREAEN	Enable the mark for zoomed area
0	Disable the mark for zoom area (default)
1	Enable the mark for zoom area
ZMAREA	Control the effect for zoomed area.
0	10 IRE bright up for inside of zoomed area (default)
1	20 IRE bright up for inside of zoomed area
2	10 IRE bright up for outside of zoomed area
3	20 IRE bright up for outside of zoomed area

Path	Index	[7]	[6]	[5]	[4]	[3]	[2]	[1]	[0]
X	1x0D	ZOOMH							

ZOOMH Define the horizontal left point of zoomed area. 4 pixels/step.
 0 Left end value (default)
 : :
 180 Right end value

Path	Index	[7]	[6]	[5]	[4]	[3]	[2]	[1]	[0]
X	1x0E	ZOOMV							

ZOOMV Define the vertical top point of zoom area. 2 lines/step.
 0 Top end value (default)
 : :
 120 Bottom end value for 60Hz, 525 lines system
 : :
 144 Bottom end value for 50Hz, 625 lines system

Path	Index	[7]	[6]	[5]	[4]	[3]	[2]	[1]	[0]
X	1x0F	FRZ_FLD		BNDCOL		BGDCOL		BLKCOL	

FRZ_FLD Select the image for freeze function or for last image capture on video loss.

- 0 Last image (default)
- 1 Last image of 1 field before
- 2 Last image of 2 fields before
- 3 Last image of 3 fields before

BNDCOL Define the channel boundary color.

- 0 0% Black
- 1 25% Gray
- 2 75% Gray
- 3 100% White (default)

Channel boundary color is changed according to this value when boundary is blinking.

- 0 100% White
- 1 100% White
- 2 0% Black
- 3 0% Black (default)

BGDCOL Define the background color.

- 0 0% Black
- 1 40% Gray (default)
- 2 75% Gray
- 3 100% Amplitude 100% Saturation Blue

BLKCOL Define the color of the blanked channel.

- 0 0% Black
- 1 40% Gray
- 2 75% Gray
- 3 100% Amplitude 100% Saturation Blue (default)

Path	CH	Index	[7]	[6]	[5]	[4]	[3]	[2]	[1]	[0]
X	0	1x10	CH_EN	POP_UP	FUNC_MODE		ANA_PATH_SEL	PB_PATH_EN	0 (RESERVED)	
	1	1x18							1 (RESERVED)	
	2	1x20							2 (RESERVED)	
	3	1x28							3 (RESERVED)	
	4	1x13			0	FUNC_MODE[0]			0 (RESERVED)	
	5	1x1B							1 (RESERVED)	
	6	1x23							2 (RESERVED)	
	7	1x2B							3 (RESERVED)	

CH_EN Enable the channel.
 0 Disable the channel (default)
 1 Enable the channel

POP_UP Enable pop-up.
 0 Disable pop-up (default)
 1 Enable pop-up

FUNC_MODE Select the operation mode.
 0 Live mode (default)
 1 Strobe mode
 2-3 Switch mode for Channel 0/1/2/3

ANA_PATH_SEL Select the switching path on PB display mode with PB_AUTO_EN = 1
 0 Main channel selection (default)
 1 Sub channel selection

PB_PATH_EN Select the input between Live and PB for each channel
 0 Normal live analog input (default)
 1 PB path input

RESERVED The following value should be set for proper operation. (default = 0)

1x10/1x13	0
1x18/1x1B	1
1x20/1x23	2
1x28/1x2B	3

Path	CH	Index	[7]	[6]	[5]	[4]	[3]	[2]	[1]	[0]
X	0	1x11	RECALL_ EN	FREEZE	H_MIRROR	V_MIRROR	ENHANCE	BLANK	BOUND	BLINK
	1	1x19								
	2	1x21								
	3	1x29								
	4	1x14								
	5	1x1C								
	6	1x24								
	7	1x2C								

RECALL_EN Enable the recall function of main channel.
 0 Disable the recall function (default)
 1 Enable the recall function

FREEZE Enable the freeze function of main channel.
 0 Normal operation (default)
 1 Enable the freeze function

H_MIRROR Enable the horizontal mirroring function of main channel.
 0 Normal operation (default)
 1 Enable the horizontal mirroring function

V_MIRROR Enable the vertical mirroring function of main channel.
 0 Normal operation (default)
 1 Enable the vertical mirroring function

ENHANCE Enable the image enhancement function of main channel.
 0 Normal operation (default)
 1 Enable the image enhancement function

BLANK Enable the blank of main channel.
 0 Disable the blank (default)
 1 Enable the blank

BOUND Enable the channel boundary of main channel.
 0 Disable the channel boundary (default)
 1 Enable the channel boundary

BLINK Enable the boundary blink of main channel when boundary is enabled.
 0 Disable the boundary blink (default)
 1 Enable the boundary blink

Path	CH	Index	[7]	[6]	[5]	[4]	[3]	[2]	[1]	[0]
X	0	1x12	0	0	FLD_OP	DVR_IN	RECALL_ADDR			
	1	1x1A								
	2	1x22								
	3	1x2A								
	4	1x15								
	5	1x1D								
	6	1x25								
	7	1x2D								

FLD_OP Enable Field to Frame conversion mode.
 0 Normal operation (default)
 1 Enable Field to Frame conversion mode

DVR_IN Enable DVR to normal conversion mode.
 0 Normal operation (default)
 1 DVR to normal conversion mode

RECALL_ADDR Define the recall address for main channel. (default = 0)
 0-3 Reserved address. Do not use this value
 4-15 Available address for 64M SDRAM

Path	CH	Index	[7]	[6]	[5]	[4]	[3]	[2]	[1]	[0]
X	0	1x16	PB_AUTO_EN	FLD_CONV	PB_STOP	EVENT_PB				PB_CH_NUM
	1	1x1E	0							
	2	1x26	0							
	3	1x2E	0							

PB_AUTO_EN Enable the auto strobe and auto cropping function for playback input
 0 Disable the auto strobe/cropping function (default)
 1 Enable the auto strobe/cropping function

FLD_CONV Enable Frame to Field conversion mode
 0 Normal operation (default)
 1 Enable Frame to Field conversion mode

PB_STOP Disable the auto strobe operation for playback input
 0 Normal operation (default)
 1 Disable the auto strobe operation for playback input

EVEN_PB Enable the event strobe function for playback input
 0 Disable the event strobe function for playback input (default)
 1 Enable the event strobe function for playback input

PB_CH_NUM Select the channel number from playback input for display (default = 0)
 PB_CH_NUM[3:2] represents the stage of cascaded chips
 0 Master chip
 1 1st slaver chip
 2 2nd slaver chip
 3 3rd slaver chip

 PB_CH_NUM[1:0] represents the channel number
 0 Channel 0
 1 Channel 1
 2 Channel 2
 3 Channel 3

Path	CH	Index	[7]	[6]	[5]	[4]	[3]	[2]	[1]	[0]
X	0	1x17	0	0	0	0	0	0	0	0
	1	1x1F								
	2	1x27								
	3	1x2F								

This is reserved register.

For normal operation, the above value should be set in this register.

Path	CH	Index	[7]	[6]	[5]	[4]	[3]	[2]	[1]	[0]
X	0	1x30	PICHL							
	1	1x34								
	2	1x38								
	3	1x3C								
	4	1x40								
	5	1x44								
	6	1x48								
	7	1x4C								

PICHL Define the horizontal left position of channel
 0 Left end (default)
 : :
 180 Right end

Path	CH	Index	[7]	[6]	[5]	[4]	[3]	[2]	[1]	[0]
X	0	1x31	PICHR							
	1	1x35								
	2	1x39								
	3	1x3D								
	4	1x41								
	5	1x45								
	6	1x49								
	7	1x4D								

PICHR Define the horizontal right position of channel region
 0 Left end (default)
 : :
 180 Right end

Path	CH	Index	[7]	[6]	[5]	[4]	[3]	[2]	[1]	[0]
X	0	1x32	PICVT							
	1	1x36								
	2	1x3A								
	3	1x3E								
	4	1x42								
	5	1x46								
	6	1x4A								
	7	1x4E								

PICVT Define the vertical top position of channel region.
 0 Top end (default)
 : :
 120 Bottom end for 60Hz system
 : :
 144 Bottom end for 50Hz system

Path	CH	Index	[7]	[6]	[5]	[4]	[3]	[2]	[1]	[0]
X	0	1x33	PICVB							
	1	1x37								
	2	1x3B								
	3	1x3F								
	4	1x43								
	5	1x47								
	6	1x4B								
	7	1x4F								

PICVB Define the vertical bottom position of channel region.
 0 Top end (default)
 : :
 120 Bottom end for 60Hz system
 : :
 144 Bottom end for 50Hz system

Index	[7]	[6]	[5]	[4]	[3]	[2]	[1]	[0]
1x50	MEDIAN_MD	TM_SLOP		TM_THR				

- MEDIAN_MD** Select the noise reduction filter mode.
- 0 Adaptive median filter mode (default)
 - 1 Simple median filter mode
- TM_SLOP** Select the slope of adaptive median filter mode
- 0 Gradient is 0
 - 1 Gradient is 1 (default)
 - 2 Gradient is 2
 - 3 Gradient is 3
- TM_THR** Select the threshold of adaptive median filter mode
- 0 No threshold
 - : :
 - 8 Median value (default)
 - : :
 - 31 Max value

Path	Index	[7]	[6]	[5]	[4]	[3]	[2]	[1]	[0]
Y	1x51	0	FRAME_OP	FRAME_FLD	DIS_MODE	0	0	SIZE_MODE	

FRAME_OP Select the frame operation mode for record path.
 0 Normal operation mode (Default)
 1 Frame operation mode

DIS_MODE Select the record mode depending on FRAME_OP.
 When FRAME_OP = 0
 0 Normal record mode (Default)
 1 DVR normal record Mode

When FRAME_OP = 1
 0 Frame record mode
 1 DVR frame record mode

FRAME_FLD Select the displayed field when FRAME_OP = "1".
 0 Odd field is displayed (default)
 1 Even field is displayed

SIZE_MODE Select the active pixel size per line
 0 720 pixels (default)
 1 704 pixels
 2 640 pixels
 3 640 pixels

Path	Index	[7]	[6]	[5]	[4]	[3]	[2]	[1]	[0]
Y	1x52	TBLINK	FRZ_FRAME	TM_WIN_MD		0	0	0	0

TBLINK Control the blink period of channel boundary.

- 0 Blink for every 30 fields (default)
- 1 Blink for every 60 fields

FRZ_FRAME Select field or frame display mode on freeze status

- 0 Field display mode (default)
- 1 Frame display mode

TM_WIN_MD Select the mask type of median/adaptive median filter

- 0 9x9 mask (default)
- 1 Cross mask
- 2 Multiplier mask
- 3 Vertical bar mask

Path	Index	[7]	[6]	[5]	[4]	[3]	[2]	[1]	[0]
Y	1x53	0	0	0	0	0	0	0	0

This is reserved register.

For normal operation, the above value should be set in this register.

Path	Index	[7]	[6]	[5]	[4]	[3]	[2]	[1]	[0]
Y	1x54	0	STRB_FLD		DUAL_PAGE	STRB_REQ			

STRB_FLD Control the field mode for strobe operation.

- 0 Capture odd field only (default)
- 1 Capture even field only
- 2 Capture first field of any field
- 3 Capture frame

DUAL_PAGE Enable dual page operation.

- 0 Normal strobe operation for each channel (default)
- 1 Enable the dual page operation

STRB_REQ Request the strobe operation.

STRB_REQ[3:0] represents the channel 3 to 0

- 0 None operation (default)
- 1 Request to start strobe operation

Path	Index	[7]	[6]	[5]	[4]	[3]	[2]	[1]	[0]
Y	1x55	NOVID_MODE		0	CH_START	0	AUTO_NR_EN	INVALID_MODE	

NOVID_MODE Select the indication method for no video detected channel

- 0 Bypass (default)
- 1 Capture last image
- 2 Blanked with blank color
- 3 Capture last image and blink channel boundary

CH_START Enable the digital channel ID in horizontal boundary of channel

- 0 Disable the digital channel ID in horizontal boundary (default)
- 1 Enable the digital channel ID in horizontal boundary

AUTO_NR_EN Enable the noise reduction filter automatically when night is detected

- 0 Disable auto noise reduction filter operation (default)
- 1 Enable auto noise reduction filter operation

INVALID_MODE Select the indication mode for no channel area

In horizontal and vertical active region

- 0 Background layer with background color (default)
- 1 Y = 0, Cb/Cr = 128
- 2 Y/Cb/Cr = 0
- 3 Y/Cb/Cr = 0

In horizontal and vertical blanking region

- 0 Y = 16, Cb/Cr = 128 (default)
- 1 Background layer with background color
- 2 Y = 0, Cb = {0, F, V, 0, Cascade, linenum[8:7]}, Cr = {0, linenum[6:0]}
- 3 Y/Cb/Cr = 0

Path	Index	[7]	[6]	[5]	[4]	[3]	[2]	[1]	[0]
Y	1x56	MUX_MODE	TRIG_MODE	MUX_FLD		PIN_TRIG_MD		PIN_TRIG_EN	
	1x57	STRB_AUTO	QUE_SIZE						

- MUX_MODE** Define the switch mode.
- 0 Switch channel with still picture (default)
 - 1 Switch channel with live picture
- TRIG_MODE** Define the switch trigger mode.
- 0 MUX with external trigger from host (default)
 - 1 MUX with internal trigger
- MUX_FLD** Control the capturing field for switch operation.
- 0 Capture odd field only (default)
 - 1 Capture even field only
 - 2 Capture frame
 - 3 Capture frame
- PIN_TRIG_MD** Select the triggering input on external trigger mode
- 0 No triggering by VLINKI Pin (default)
 - 1 Triggering by positive edge of VLINKI pin
 - 2 Triggering by negative edge of VLINKI pin
 - 3 Triggering by both positive and negative edge of VLINKI pin
- PIN_TRIG_EN** Enable triggering by VLINKI Pin
- [0] is stand for switching control, [1] is stand for popup position control
- 0 Disable pin triggering (default)
 - 1 Enable pin triggering
- STRB_AUTO** Enable automatic strobe mode when FUNC_MODE = "1"
- 0 Manual strobe mode (default)
 - 1 Automatic strobe mode
- QUE_SIZE** Define the actually using queue size in switching mode.
- 0 Queue size = 1 (default)
 - : :
 - 127 Queue size = 128

Path	Index	[7]	[6]	[5]	[4]	[3]	[2]	[1]	[0]
Y	1x58	QUE_PERIOD [7:0]							
	1x59	QUE_PERIOD [9:8]	EXT_TRIG	INTR_REQ	MUX_WR_CH				

- QUE_PERIOD** Control the trigger period for internal trigger mode.
 0 Trigger period = 1 field (default)
 : :
 1023 Trigger period = 1024 fields
- EXT_TRIG** Make trigger when TRIG_MODE = "0" (external trigger mode).
 0 None operation (default)
 1 Request to start MUX with external trigger mode
- INTR_REQ** Request to start the switch operation by interrupt
 0 None operation (default)
 1 Request to start the switch operation by interrupt
- MUX_WR_CH** Define the channel number to be written in internal MUX queue or in interrupt trigger.
 MUX_WR_CH[3:2] stands for stage of cascaded chips
 0 Master chip (default)
 1 1st slaver chip
 2 2nd slaver chip
 3 3rd slaver chip
- MUX_WR_CH[1:0] stands for channel number
 0 Channel 0 (default)
 1 Channel 1
 2 Channel 2
 3 Channel 3

Path	Index	[7]	[6]	[5]	[4]	[3]	[2]	[1]	[0]
Y	1x5A	QUE_WR	QUE_ADDR						

QUE_WR Control to write the data of internal queue.
 0 None operation (default)
 1 Request to write the QUE_CH in QUE_ADDR of internal queue

QUE_ADDR Define the queue address.
 0 1st queue address (default)
 : :
 127 128th queue address

Path	Index	[7]	[6]	[5]	[4]	[3]	[2]	[1]	[0]
Y	1x5B	0	Q_POS_RD_CTL	Q_DATA_RD_CTL	MUX_SKIP_EN	ACCU_TRIG	QUE_CNT_RST	QUE_POS_RST	
	1x5C	MUX_SKIP_CH[15:8]							
	1x5D	MUX_SKIP_CH[7:0]							

- Q_POS_RD_CTL** Control the read mode of the QUE_ADDR
- 0 Current queue address of internal queue (default)
 - 1 Written value into the QUE_ADDR
- Q_DATA_RD_CTL** Control the read mode of the MUX_WR_CH
- 0 Current queue data of internal queue (default)
 - 1 Written value into the MUX_WR_CH
 - 2,3 Queue data at the QUE_ADDR
- MUX_SKIP_EN** Enable the switch skip mode
- 0 Disable the switch skip mode
 - 1 Enable the switch skip mode
- ACCU_TRIG** Adjust the switch timing in external triggering via the VLINK1 pin
- 0 Output is delayed in 4 fields from triggering (default)
 - 1 Output is matched with triggering
- QUE_CNT_RST** Reset the internal field counter to count queue period.
- 0 None operation (default)
 - 1 Reset the field counter
- QUE_POS_RST** Reset the queue address.
- 0 None operation (default)
 - 1 Reset the queue address and restart address
- MUX_SKIP_CH** Define the switch skip channel
- MUX_SKIP_CH[15:0] stands for channel 15 ~ 0 including cascaded chip
- 0 Normal operation (default)
 - 1 Skip channel

Path	Index	[7]	[6]	[5]	[4]	[3]	[2]	[1]	[0]
Y	1x5E	CHID_MUX_OUT *							

Notes “*” stand for read only register

CHID_MUX_OUT Channel ID of current field/frame in switch operation (Read only register)
 CHID_MUX_OUT [7] represents the channel ID latch enabling pulse
 0->1 Rising edge for updating the channel ID
 1->0 Falling edge after 16 clock * 18.5 ns from rising edge

CHID_MUX_OUT [6] represents the updated picture in switch operation
 0 No Updated
 1 Updated by New Switching

CHID_MUX_OUT [5] represents the field mode in switch operation
 0 Frame mode
 1 Field mode

CHID_MUX_OUT [4] represents the analog switching path
 0 Analog switching 0 path
 1 Analog switching 1 path

CHID_MUX_OUT [3:2] represents the stage of cascaded chip for switch operation
 0 Master chip
 1 1st slaver chip
 2 2nd slaver chip
 3 3rd slaver chip

CHID_MUX_OUT [1:0] represents the channel number for switch operation
 0 Channel 0
 1 Channel 1
 2 Channel 2
 3 Channel 3

Path	Index	[7]	[6]	[5]	[4]	[3]	[2]	[1]	[0]
Y	1x5F	FRZ_FLD		BNDCOL		BGDCOL		BLKCOL	

FRZ_FLD Select the image for freeze function or for last capturing mode on video loss.

- 0 Last image (default)
- 1 Last image of 1 field before
- 2 Last image of 2 fields before
- 3 Last image of 3 fields before

BNDCOL Define the boundary color of channel.

- 0 0% Black
- 1 25% Gray
- 2 75% Gray
- 3 100% White (default)

Channel boundary color is changed according to this value when boundary is blinking.

- 0 100% White
- 1 100% White
- 2 0% Black
- 3 0% Black (default)

BGDCOL Define the background color.

- 0 0% Black
- 1 40% Gray (default)
- 2 75% Gray
- 3 100% Amplitude 100% Saturation Blue

BLKCOL Define the color of the blanked channel.

- 0 0% Black
- 1 40% Gray
- 2 75% Gray
- 3 100% Amplitude 100% Saturation Blue (default)

Path	CH	Index	[7]	[6]	[5]	[4]	[3]	[2]	[1]	[0]
Y	0	1x60	CH_EN	POP_UP	FUNC_MODE	NR_EN_DM	NR_EN	DEC_PATH_Y		
	1	1x63								
	2	1x66								
	3	1x69								

CH_EN

Enable the channel.

- 0 Disable the channel (default)
- 1 Enable the channel

POP_UP

Enable the pop-up attribute.

- 0 Disable the pop-up attribute (default)
- 1 Enable the pop-up attribute

FUNC_MODE

Select the operation mode.

- 0 Live mode (default)
- 1 Strobe mode
- 2-3 Switch mode

NR_EN

Enable the noise reduction filter in main path with ANA_SW = 0

NR_EN_DM

Enable the noise reduction filter in sub path with ANA_SW = 1

- 0 Disable the noise reduction filter (default)
- 1 Enable the noise reduction filter

DEC_PATH_Y

Select the video input for each channel.

- 0 Video input from internal video decoder on VIN0 pins (default)
- 1 Video input from internal video decoder on VIN1 pins
- 2 Video input from internal video decoder on VIN2 pins
- 3 Video input from internal video decoder on VIN3 pins

Path	CH	Index	[7]	[6]	[5]	[4]	[3]	[2]	[1]	[0]
Y	0	1x61	0	FREEZE	H_MIRROR	V_MIRROR	0	BLANK	BOUND	BLINK
	1	1x64								
	2	1x67								
	3	1x6A								

FREEZE Enable the freeze function of main channel.

- 0 Normal operation (default)
- 1 Enable the freeze function

H_MIRROR Enable the horizontal mirroring function of main channel.

- 0 Normal operation (default)
- 1 Enable the horizontal mirroring function

V_MIRROR Enable the vertical mirroring function of main channel.

- 0 Normal operation (default)
- 1 Enable the vertical mirroring function

BLANK Enable the blank of main channel.

- 0 Disable the blank (default)
- 1 Enable the blank

BOUND Enable the channel boundary of main channel.

- 0 Disable the channel boundary (default)
- 1 Enable the channel boundary

BLINK Enable the boundary blink of main channel when boundary is enabled.

- 0 Disable the boundary blink (default)
- 1 Enable the boundary blink

Path	CH	Index	[7]	[6]	[5]	[4]	[3]	[2]	[1]	[0]
Y	0	1x62	0	0	FIELD_OP	0	0	0	0	0
	1	1x65								
	2	1x68								
	3	1x6B								

FIELD_OP Enable Field to Frame conversion mode.
 0 Normal operation (default)
 1 Enable Field to Frame conversion mode

Path	Index	[7]	[6]	[5]	[4]	[3]	[2]	[1]	[0]
Y	1x6C	PIC_SIZE3		PIC_SIZE2		PIC_SIZE1		PIC_SIZE0	

PIC_SIZE Define the channel size
 in normal record mode or DVR normal record mode
 0 Half Size for both direction (360x120/144) (default)
 1 Half size for vertical size (720x120/144)
 2 Half size for horizontal size (360x240/288)
 3 Full size (720x240/288)

in Frame record mode or DVR frame record mode
 0 Half size for horizontal size (360x240/288)
 1 Full size for horizontal size (720x240/288)
 2/3 Not supported

Path	Index	[7]	[6]	[5]	[4]	[3]	[2]	[1]	[0]
Y	1x6D	PIC_POS3		PIC_POS2		PIC_POS1		PIC_POS0	

PIC_POS

Define the channel start position

in Normal record mode

- 0 No offset for both horizontal and vertical direction (default)
- 1 Half offset for horizontal and no offset for vertical direction
- 2 No offset for horizontal and half offset for vertical direction
- 3 Half offset for horizontal and half offset for vertical direction

in Frame record mode

- 0 No offset for both horizontal and vertical direction
- 1 Half offset for horizontal and no offset for vertical direction
- 2 No offset for horizontal and field offset for vertical direction
- 3 Half offset for horizontal and field offset for vertical direction

in DVR normal record mode

- 0 No offset for both horizontal and vertical direction
- 1 Quarter offset for vertical direction
- 2 Half offset for vertical direction
- 3 Three Quarter offset for vertical direction

in DVR Frame record mode

- 0 No offset for both horizontal and vertical direction
- 1 Half offset for vertical direction
- 2 Field offset for vertical direction
- 3 Field and half offset for vertical direction

Path	Index	[7]	[6]	[5]	[4]	[3]	[2]	[1]	[0]
Y	1x6E	MUX_OUT_CH0 *				MUX_OUT_CH1 *			
	1x6F	MUX_OUT_CH2 *				MUX_OUT_CH3 *			

Notes “*” stand for read only register

MUX_OUT_CH0 Channel Information in current field/frame for switch operation

MUX_OUT_CH1 Channel Information in next field/frame for switch operation

MUX_OUT_CH2 Channel Information after 2 fields for switch operation

MUX_OUT_CH3 Channel Information after 3 fields for switch operation

MUX_OUT_CH [3:2] represents the stage of cascaded chips

0 Master chip (default)

1 1st slaver chip

2 2nd slaver chip

3 3rd slaver chip

MUX_OUT_CH [1:0] represents the channel number

0 Channel 0 (default)

1 Channel 1

2 Channel 2

3 Channel 3

Path	Index	[7]	[6]	[5]	[4]	[3]	[2]	[1]	[0]
Y	1x70	POS_CTL_EN	POS_TRIG_MODE	POS_TRIG	POS_INTR	0	POS_RD_CTL	POS_DATA_RD_CTL	

- POS_CTL_EN** Enable the position/popup control
- 0 Disable the position/popup control (default)
 - 1 Enable the position/popup control
- POS_TRIG_MODE** Select the position/popup trigger mode
- 0 External trigger mode (default)
 - 1 Internal trigger mode
- POS_TRIG** Request the external trigger on external trigger mode
- 0 None Operation (default)
 - 1 Request to start position/popup control in external trigger mode
- POS_INTR** Request to start position/popup control with interrupt
- 0 None Operation (default)
 - 1 Request to start position/popup control with interrupt
- POS_RD_CTL** Control the read mode for the POS_QUE_ADDR
- 0 Current queue address for internal position/popup queue (default)
 - 1 Written value into the POS_QUE_ADDR
- POS_DATA_RD_CTL** Control the read mode for the POS_CH
- 0 Current queue data for internal queue position (default)
 - 1 Written POS_CH value
 - 2 Queue data of the POS_QUE_ADDR
 - 3 Queue data of the POS_QUE_ADDR

Path	Index	[7]	[6]	[5]	[4]	[3]	[2]	[1]	[0]
Y	1x71	POS_QUE_PER[9:8]		POS_FLD_MD	POS_QUE_SIZE				
	1x72	POS_QUE_PER [7:0]							
	1x73	POS_CH0				POS_CH1			
	1x74	POS_CH2				POS_CH3			

- POS_QUE_SIZE** Control the position/popup queue size
 0 Queue size = 1 (default)
 : :
 31 Queue size = 32
- POS_FLD_MD** Select the position/popup queue period unit
 0 Frame (default)
 1 Field
- POS_QUE_PER** Control the trigger period for internal trigger mode.
 0 Trigger period = 1 field or frame (default)
 : :
 1023 Trigger period = 1024 fields or frames
- POS_CH** Define the channel for each region
 POS_CH0 stands for no offset region of both H/V
 POS_CH1 stands for half offset of H
 POS_CH2 stands for half offset of V
 POS_CH3 stands for half offset of both H/V
 POS_CH [3:2] stands for the stage of cascaded chips
 0 Master chip (default)
 1 1st slaver chip
 2 2nd slaver chip
 3 3rd slaver chip
- POS_CH [1:0] stands for the channel number
 0 Channel 0 (default)
 1 Channel 1
 2 Channel 2
 3 Channel 3

Path	Index	[7]	[6]	[5]	[4]	[3]	[2]	[1]	[0]
Y	1x75	POS_QUE_WR	POS_CNT_RST	POS_QUE_RST	POS_QUE_ADDR				

POS_QUE_WR Control to write the data of internal position queue

- 0 None operation (default)
- 1 Write data into the POS_CH register at the POS_QUE_ADDR

POS_CNT_RST Reset the internal field counter to count queue period of position queue.

- 0 None operation (default)
- 1 Reset the field counter

POS_QUE_RST Reset the queue address of position queue.

- 0 None operation (default)
- 1 Reset the queue address and restart address

POS_QUE_ADDR Define the queue address.

- 0 1st queue address (default)
- : :
- 31 32nd queue address

Index	[7]	[6]	[5]	[4]	[3]	[2]	[1]	[0]
1x76	IRQENA_RD	0	0	0	0	0	IRQ_POL	IRQ_RPT
1x77	IRQ_PERIOD							

IRQENA_RD Select the read mode for IRQENA_XX registers

- 0 Read the Status/Event information (default)
IRQ event will be cleared after host reads IRQENA_XX registers.
- 1 Read the written data
IRQ event is not cleared even if host reads IRQENA_XX registers.

IRQ_POL Select the IRQ polarity.

- 0 Active high (default)
- 1 Active low

IRQ_RPT Select the IRQ mode.

- 0 IRQ pin maintains the state “1” until the interrupt request is cleared (default)
- 1 Interrupt request is repeated with 5msec period via IRQ pin when the interrupt is not cleared in long time.

IRQ_PERIOD Control the interrupt generation period (The unit is field).

- 0 Immediate generation of interrupt when any Interrupt happens
- : :
- 255 Interrupt generation by the duration of the IRQ_PERIOD

Index	[7]	[6]	[5]	[4]	[3]	[2]	[1]	[0]
1x78	IRQENA_NOVID							

IRQENA_NOVID Enable the interrupt for video loss detection.

IRQENA_NOVID[3:0] stand for VIN3 to VIN0 with ANMA_SW = 0
 IRQENA_NOVID[7:4] stand for VIN3 to VIN0 with ANMA_SW = 1

- 0 Video-loss interrupt is disabled (default)
- 1 Video-loss interrupt is enabled

The read information is determined by the IRQENA_RD (1x76). When the IRQ_ENA_RD = “0”, the information is like the following and the interrupt will be cleared when the register is read by host.

- 0 Video is alive (default)
- 1 Video loss is detected

Index	[7]	[6]	[5]	[4]	[3]	[2]	[1]	[0]
1x79	IRQENA_MD							
1x7A	IRQENA_BD							
1x7B	IRQENA_ND							

IRQENA_MD

Enable the interrupt for motion detection.

IRQENA_MD[3:0] stand for VIN3 to VIN0 with ANA_SW = 0

IRQENA_MD[7:4] stand for VIN3 to VIN0 with ANA_SW = 1

0 Motion interrupt is disabled (default)

1 Motion interrupt is enabled

The read information is determined by the IRQENA_RD (1x76). When the IRQ_ENA_RD = "0", the information is like the following and the interrupt will be cleared when the register is read by host.

0 No motion is detected (default)

1 Motion is detected

IRQENA_BD

Enable the interrupt for blind detection.

IRQENA_BD [3:0] stand for VIN3 to VIN0 with ANA_SW = 0.

IRQENA_BD [7:4] stand for VIN3 to VIN0 with ANA_SW = 1.

0 Blind interrupt is disabled (default)

1 Blind interrupt is enabled

The read information is determined by the IRQENA_RD (1x76). When the IRQ_ENA_RD = "0", the information is like the following and the interrupt will be cleared when the register is read by host.

0 No blind is detected (default)

1 Blind is detected

IRQENA_ND

Enable the interrupt for night detection.

IRQENA_ND [3:0] stand for VIN3 to VIN0 with ANA_SW = 0.

IRQENA_ND [7:4] stand for VIN3 to VIN0 with ANA_SW = 1.

0 Night interrupt is disabled (default)

1 Night interrupt is enabled

The read information is determined by the IRQENA_RD (1x76). When the IRQ_ENA_RD = "0", the information is like the following and the interrupt will be cleared when the register is read by host.

0 Day is detected (default)

1 Night is detected

Index	[7]	[6]	[5]	[4]	[3]	[2]	[1]	[0]
1x7C	PB_NOVID_DET*				0	0	0	0

Notes “*” stand for read only register

PB_NOVID_DET Status for playback input
 0 Playback input is alive
 1 Video-loss is detected for playback input

Index	[7]	[6]	[5]	[4]	[3]	[2]	[1]	[0]
1x7D	0							

This is reserved register.

For normal operation, the above value should be set in this register.

Index	[7]	[6]	[5]	[4]	[3]	[2]	[1]	[0]
1x7E	1	SYNC_DEL			MCLKDEL			

SYNC_DEL Control relative data delay for cascade channel extension
 SYNC_DEL should be defined to have 2 offset from slaver chip.
 Please refer to Fig 49 ~ Fig 52 for reference.
 The default value is 0.

MCLKDEL Control the clock delay of the CLK54MEM pin
 The delay can be controlled about 1ns.
 The default value is 0.

Index	[7]	[6]	[5]	[4]	[3]	[2]	[1]	[0]
1x7F	MEM_INIT	0	T_CASCADE_EN	0	0	1	0	0

MEM_INIT Initialize the operation mode of SDRAM.
 This is cleared by itself after setting "1".
 0 None operation (default)
 1 Request to start initializing operation mode of SDRAM

T_CASCADE_EN Enable the infinite cascade mode for display path
 0 Normal operation (default)
 1 Enable the infinite cascade mode for display path

Index	[7]	[6]	[5]	[4]	[3]	[2]	[1]	[0]
1x80	VIS_ENA	VIS_AUTO_EN	AUTO_RPT_EN	VIS_DET_EN	VIS_USER_EN	VIS_CODE_EN	VIS_RIC_EN	1
1x81	VIS_PIXEL_HOS							

VIS_ENA Enable the Analog channel ID during vertical blanking interval
 0 Disable the Analog channel ID (default)
 1 Enable the Analog channel ID

VIS_AUTO_EN Enable the Auto channel ID In Analog channel ID
 0 Disable the Auto channel ID (default)
 1 Enable the Auto channel ID

AUTO_RPT_EN Enable the Auto channel ID repetition mode in Analog channel ID
 0 Disable the Auto channel ID repetition mode (default)
 1 Enable the Auto channel ID repetition mode

VIS_DET_EN Enable the Detection channel ID in Analog channel ID
 0 Disable the Detection channel ID (default)
 1 Enable the Detection channel ID

VIS_USER_EN Enable the User channel ID in Analog channel ID
 0 Disable the User channel ID (default)
 1 Enable the User channel ID

VIS_CODE_EN Enable the Digital channel ID
 0 Disable the Digital channel ID (default)
 1 Enable the Digital channel ID

VIS_RIC_EN Enable the run-in clock of Analog channel ID during VBI
 0 Disable the run-in clock (default)
 1 Enable the run-in clock

VIS_PIXEL_HOS Define the horizontal starting offset for Analog channel ID
 0 No offset (default)
 : :
 Table 1 255 pixel Offset

Index	[7]	[6]	[5]	[4]	[3]	[2]	[1]	[0]
1x82	VIS_FLD_OS		0	VIS_PIXEL_WIDTH				
1x83	0	VIS_DM_MD	0	VIS_LINE_OS				
1x84	VIS_HIGH_VAL							
1x85	VIS_LOW_VAL							

- VIS_FLD_OS** Control the vertical starting offset of each field for Analog channel ID
- 0 Odd : 1 Line, Even : 0 Line (default)
 - 1 Odd : 1 Line, Even : 1 Line
 - 2 Odd : 1 Line, Even : 2 Line
 - 3 Odd : 1 Line, Even : 3 Line
- VIS_DM_MD** Select the non-realtime mode for Detection channel ID
- 0 Normal mode (default)
 - 1 Non-realtime Mode
- VIS_PIXEL_WIDTH** Control the pixel width of each bit for Analog channel ID
- 0 1 pixel
 - : :
 - 31 32 pixels (default)
- VBI_LINE_OS** Control the vertical starting offset from field transition for Analog channel ID
- 0 No offset
 - : :
 - 8 7 lines (default)
 - : :
 - Table 1 31 lines
- VIS_HIGH_VAL** Magnitude value for bit "1" of Analog channel ID (default = 235)
- VIS_LOW_VAL** Magnitude value for bit "0" of Analog channel ID (default = 16)

Index	[7]	[6]	[5]	[4]	[3]	[2]	[1]	[0]
1x86	AUTO_VBI_DET	0	VBI_ENA	VBI_CODE_EN	VBI_RIC_ON	VBI_FLT_EN	CHID_RD_TYPE	VBI_RD_CTL

AUTO_VBI_DET	Select the detection mode of Analog channel ID for playback input 0 Manual detection mode for Analog channel ID (default) 1 Automatic detection mode for Analog channel ID
VBI_ENA	Enable the Analog channel ID detection for playback input 0 Disable the Analog channel ID detection (default) 1 Enable the Analog channel ID detection
VBI_CODE_EN	Enable the Digital channel ID detection for playback input 0 Disable the Digital channel ID detection mode (default) 1 Enable the Digital channel ID detection mode
VBI_RIC_ON	Select the run-in clock mode for Analog channel ID 0 No run-in clock mode (default) 1 Run-in clock mode
VBI_FLT_EN	Select the LPF filter mode for playback input 0 Bypass mode (default) 1 Enable the LPF filter
CHID_RD_TYPE	Control the read mode of channel ID decoder 0 Read the channel valid data from channel ID decoder (default) 1 Read the channel ID type from channel ID decoder
VBI_RD_CTL	Control the read mode of channel ID for channel ID CODEC (default = 0) Table 1 Read the written data into USER_CHID registers (1x90 ~ 1x97) Read the encoded result in DET_CHID registers (1X98 ~ 1x9F) Read the encoded ID data from AUTO_CHID registers. (1x8C ~ 1x8F) Table 1 Read the decoded ID data from USER_CHID registers (1x90 ~ 1x97) Read the decoded result for DET_CHID registers (1X98 ~ 1x9F) Read the decoded ID data from AUTO_CHID registers (1x8C ~ 1x8F)

Index	[7]	[6]	[5]	[4]	[3]	[2]	[1]	[0]
1x87	VBI_PIXEL_HOS							
1x88	VBI_FLD_OS	VAV_CHK	VBI_PIXEL_HW					

VBI_PIXEL_HOS Define the horizontal starting offset of Analog channel ID
 When Manual detection mode of Analog channel ID (AUTO_VBI_DET = 0)
 0 No offset (Not supported in No run-in clock mode) (default)
 ::
 Table 1 255 pixel offset

When Auto detection mode of Analog channel ID (AUTO_VBI_DET = 1),
 this register notifies the detected horizontal starting offset for Analog
 channel ID.

VBI_FLD_OS Control the vertical starting offset of each field for Analog channel ID
 0 Odd : 1 Line, Even : 0 Line (default)
 1 Odd : 1 Line, Even : 1 Line
 2 Odd : 1 Line, Even : 2 Line
 3 Odd : 1 Line, Even : 3 Line

VAV_CHK Enable the channel ID detection in vertical active period
 0 Enable the channel ID detection for VBI period only (default)
 1 Enable the channel ID detection for VBI and vertical active period

VBI_PIXEL_HW Control the pixel width for each bit of Analog channel ID
 0 1 pixel (default)
 ::
 Table 1 32 pixels

Index	[7]	[6]	[5]	[4]	[3]	[2]	[1]	[0]
1x89	VBI_LINE_WIDTH			VBI_LINE_OS				
1x8A	VBI_MID_VAL							
1x8B	CHID_TYPE/CHID_VALID *							

Notes “*” stand for read only register

VBI_LINE_WIDTH Control the line width for Analog channel ID
 When Manual detection mode of Analog channel ID (AUTO_VBI_DET = 0)
 0 1 line
 : :
 Table 1 8 lines (default)

When Auto detection mode of Analog channel ID (AUTO_VBI_DET = 1),
 this register notifies the detected line width for Analog channel ID.

VBI_LINE_OS Control the vertical starting offset from field transition for Analog channel ID
 0 No offset
 : :
 8 7 lines (default)
 : :
 Table 1 31 lines

VBI_MID_VAL Define the threshold level to detect bit “0” or bit “1” from Analog channel ID
 (default = 128)

CHID_VALID Status for validity of detected channel ID when CHID_RD_TYPE = 0
 CHID_VALID[4] stands for Auto Channel ID
 CHID_VALID[3] stands for Detection Channel ID 0
 CHID_VALID[2] stands for Detection Channel ID 1
 CHID_VALID[1] stands for User Channel ID 0
 CHID_VALID[0] stands for User Channel ID 1
 0 Not Valid
 1 Valid

CHID_TYPE Indication of the detected channel ID type when CHID_RD_TYPE = 1
 CHID_TYPE[5:0] stands for line number for Analog channel ID
 0 Auto channel ID
 1 User/Detection channel ID

Index	[7]	[6]	[5]	[4]	[3]	[2]	[1]	[0]
1x8C								AUTO_CHID0*
1x8D								AUTO_CHID1*
1x8E								AUTO_CHID2*
1x8F								AUTO_CHID3*
1x90								USER_CHID0
1x91								USER_CHID1
1x92								USER_CHID2
1x93								USER_CHID3
1x94								USER_CHID4
1x95								USER_CHID5
1x96								USER_CHID6
1x97								USER_CHID7
1x98								DET_CHID0 *
1x99								DET_CHID1 *
1x9A								DET_CHID2 *
1x9B								DET_CHID3 *
1x9C								DET_CHID4 *
1x9D								DET_CHID5 *
1x9E								DET_CHID6 *
1x9F								DET_CHID7 *

Notes “*” stand for read only register

AUTO_CHID Data information of Auto channel ID
 USER_CHID Data information of User channel ID (default = 0)
 USER_CHID 0/1/2/3 stands for 1st line channel ID
 USER_CHID 4/5/6/7 stands for 2nd line channel ID
 DET_CHID Data information of Detection channel ID
 DET_CHID 0/1/2/3 stands for 1st line channel ID
 DET_CHID 4/5/6/7 stands for 2nd line channel ID

Read mode depends on VBI_RD_CTL register
 0 Encoded Auto/User/Detection channel ID
 1 Decoded Auto/User/Detection channel ID

Index	[7]	[6]	[5]	[4]	[3]	[2]	[1]	[0]
1xA0	ENC_IN_X		ENC_IN_Y		CCIR_IN_X		CCIR_IN_Y	

ENC_IN Select the video data for analog output of video encoder.

- 0 Video data of display path without OSD and mouse overlay (default)
- 1 Video data of display path with OSD and mouse overlay
- 2 Video data of record path without OSD and mouse overlay
- 3 Video data of record path with OSD and mouse overlay

CCIR_IN Select the video data for ITU-R BT 656 digital output.

- 0 Video data of display path without OSD and mouse overlay (default)
- 1 Video data of display path with OSD and mouse overlay
- 2 Video data of record path without OSD and mouse overlay
- 3 Video data of record path with OSD and mouse overlay

Index	[7]	[6]	[5]	[4]	[3]	[2]	[1]	[0]
1xA1	DAC_PD_CX	0	DAC_OUT_YX		DAC_PD_YX	0	DAC_OUT_CX	

DAC_PD_YX Enable the power down of VAOYX DAC.

DAC_PD_CX Enable the power down of VAOCX DAC.

- 0 Normal operation (default)
- 1 Enable power down of DAC

DAC_OUT_YX Define the analog video format for VAOYX DAC.

DAC_OUT_CX Define the analog video format for VAOCX DAC.

- 0 No Output (default)
- 1 CVBS for display path
- 2 Luminance for display path
- 3 Chrominance for display path

Index	[7]	[6]	[5]	[4]	[3]	[2]	[1]	[0]
1xA2	1	DAC_OUT_YY			DAC_PD_YY	0	0	0

DAC_PD_YY Enable the power down of VAOYY DAC.

- 0 Normal operation (default)
- 1 Enable power down of DAC

DAC_OUT_YY Define the analog video format for VAOYY DAC.

- 0 No Output (default)
- 1 CVBS for display path
- 2 Not supported
- 3 Not supported
- 4 Not supported
- 5 CVBS for record path
- 6 Not supported
- 7 Not supported

Path		Display				Record
Format		No Output	CVBS	Luma	Chroma	CVBS
Output	VAOYX	O	O	O	O	X
	VAOCX	O	O	O	O	X
	VAOYY	O	O	X	X	O

Index	[7]	[6]	[5]	[4]	[3]	[2]	[1]	[0]
1xA3	CCIR_601	0	CCIR_OUT_X	CCIR_601_INV	0	CCIR_OUT_Y		

CCIR_601 Define the digital data output format.

- 0 ITU-R BT.656 mode (default)
- 1 ITU-R BT.601 mode

CCIR_601_INV Swap Y/C output port when CCIR_601 = 1

- 0 VDOX : Y output, VDOY : C output (default)
- 1 VDOX : C output, VDOY : Y output

CCIR_OUT Define the mode of ITU-R BT.656 digital output.

The default value is "0" for CCIR_OUT_X, but "1" for CCIR_OUT_Y.

When ITU-R BT.656 is selected (CCIR_601 = 0)

- 0 Display path video data with single output mode (27MHz)
- 1 Record path video data with single output mode (27MHz)
- 2 Display and Record path video data with dual output mode (54MHz)
- 3 Record and Display path video data with dual output mode (54MHz)

When ITU-R BT.601 is selected (CCIR_601 = 1)

- 0 Display path video data with single output mode (13.5MHz)
- 1 Record path video data with single output mode (13.5MHz)
- 2 Dual output mode with Display and Record path video data (27MHz)
- 3 Dual output mode with Record and Display path video data (27MHz)

Index	[7]	[6]	[5]	[4]	[3]	[2]	[1]	[0]
1xA4	ENC_MODE	CCIR_LMT	ENC_VS	ENC_FLD	CCIR_FLDPOL	ENC_HSPOL	ENC_VSPOL	ENC_FLDPOL

- ENC_MODE Define the operation mode of video encoder.
 0 Slave operation mode (default)
 1 Master operation mode
- CCIR_LMT Control the data range of ITU-R BT 656 output.
 0 Not limited (default)
 1 Data range is limited to 1 ~ 254 code
- ENC_VS Define the vertical sync detection type.
 0 Detect vertical sync from VSENC pin (default)
 1 Detect vertical sync from combination of HSENC and FLDEN pins
- ENC_FLD Define the field polarity detection type
 0 Detect field polarity from FLDENC pin (default)
 1 Detect field polarity from combination of HSENC and VSENC pins
- CCIR_FLDPOL Control the field polarity of ITU-R BT 656 output.
 0 High for even field (default)
 1 High for odd field
- ENC_HSPOL Control the horizontal sync polarity.
 0 Active low (default)
 1 Active high
- ENC_VSPOL Control the vertical sync polarity.
 0 Active low (default)
 1 Active high
- ENC_FLDPOL Control the field polarity.
 0 Even field is high (default)
 1 Odd field is high

Index	[7]	[6]	[5]	[4]	[3]	[2]	[1]	[0]
1xA5	ENC_VSOFF		ENC_VSDEL					

ENC_VSOFF Compensate the field offset for first active video line.

0 Apply same ENC_VSDEL for odd and even field (default)

1 Apply {ENC_VSDEL+1} for odd and ENC_VSDEL for even field

2 Apply ENC_VSDEL for odd and {ENC_VSDEL +1} for even field

3 Apply ENC_VSDEL for odd and {ENC_VSDEL +2} for even field

ENC_VSDEL Control the line delay of vertical sync from active video by 1 line/step.

0 No delayed

: :

32 32 line delay (default)

: :

Table 1 63 line delay

Index	[7]	[6]	[5]	[4]	[3]	[2]	[1]	[0]
1xA6	ENC_HSDEL[9:2]							
1xA7	ENC_HSDEL[1:0]		0	ACTIVE_VDEL				

ENC_HSDEL Control the pixel delay of horizontal sync from active video by 1/2 pixel/step.

0 No delayed

: :

128 64 pixel delay (default)

: :

1023 255 pixel delay

ACTIVE_VDEL Control the line delay of active video by 1 line/step.

0 - 11 Lines delayed

: :

12 0 Line delayed (default)

: :

Table 1 + 13 Lines delayed

Index	[7]	[6]	[5]	[4]	[3]	[2]	[1]	[0]
1xA8	ACTIVE_MD	CCIR_STD	ACTIVE_HDEL					
1xA9	ENC_FSC		0	0	1	ENC_PHALT	ENC_ALTRST	ENC_PED

- ACTIVE_MD** Select the active delay mode for digital BT. 656 output
- 0 Control the active delay for both analog encoder and digital output (default)
 - 1 Control the active delay for only analog encoder
- CCIR_STD** Select the ITU-R BT656 standard format for 60Hz system.
- 0 240 line for odd and even field (default)
 - 1 244 line for odd and 243 line for even field (ITU-R BT.656 standard)
- ACTIVE_HDEL** Control the pixel delay of active video by 1 pixel/step.
- 0 - 32 Pixel delay
 - : :
 - 32 0 Pixel delay (default)
 - : :
 - 63 + 31 Pixel delay
- ENC_FSC** Set color sub-carrier frequency for video encoder.
- 0 3.57954545 MHz (default)
 - 1 4.43361875 MHz
 - 2 3.57561149 MHz
 - 3 3.58205625 MHz
- ENC_PHALT** Set the phase alternation.
- 0 Disable phase alternation for line-by-line (default)
 - 1 Enable phase alternation for line-by-line
- ENC_ALTRST** Reset the phase alternation every 8 field
- 0 No reset mode (default)
 - 1 Reset the phase alternation every 8 field
- ENC_PED** Set 7.5IRE for pedestal level
- 0 0 IRE for pedestal level
 - 1 7.5 IRE for pedestal level (default)

Index	[7]	[6]	[5]	[4]	[3]	[2]	[1]	[0]
1xAA	ENC_CBW_X		ENC_YBW_X		ENC_CBW_Y		ENC_YBW_Y	

ENC_CBW Control the chrominance bandwidth of video encoder.
 0 0.8 MHz
 1 1.15 MHz
 2 1.35 MHz (default)
 3 1.35 MHz

ENC_YBW Control the luminance bandwidth of video encoder.
 0 Narrow bandwidth
 1 Narrower bandwidth
 2 Wide bandwidth (default)
 3 Middle band width

Index	[7]	[6]	[5]	[4]	[3]	[2]	[1]	[0]
1xAB	0	HOUT*	VOUT*	FOUT*	ENC_BAR_X	ENC_CKILL_X	ENC_BAR_Y	ENC_CKILL_Y

Notes “**” stand for read only register

HOUT Status of horizontal sync for encoder timing
 VOUT Status of vertical sync for encoder timing
 FOUT Status of field polarity for encoder timing

ENC_BAR Enable the test pattern output.
 0 Normal operation (default)
 1 Internal color bar with 100% amplitude 100 % saturation

ENC_CKILL Enable the color killing function
 0 Normal operation (default)
 1 Color is killed

Index	[7]	[6]	[5]	[4]	[3]	[2]	[1]	[0]
1xAC	ENC_CLK_FR_X		ENC_CLK_PH_X		ENC_CLKDEL_X			
1xAD	ENC_CLK_FR_Y		ENC_CLK_PH_Y		ENC_CLKDEL_Y			
1xAE	DEC_CLK_FR_X		DEC_CLK_PH_X		DEC_CLKDEL_X			
1xAF	DEC_CLK_FR_Y		DEC_CLK_PH_Y		DEC_CLKDEL_Y			

- ENC_CLK_FR_X Control the clock frequency of CLKVDOX pin (default = 1, 27MHz)
- ENC_CLK_FR_Y Control the clock frequency of CLKVDOY pin (default = 1, 27MHz)
- DEC_CLK_FR_X Control the clock frequency of CLKMPP1 pin (default = 2, 27MHz)
- DEC_CLK_FR_Y Control the clock frequency of CLKMPP2 pin (default = 0, 54MHz)
- 0 54MHz
- 1 27MHz for Memory Controlled Digital Output
- 2 27MHz for Decoder Bypassed Digital Output
- 3 13.5MHz for Memory Controlled Digital Output
-
- ENC_CLK_PH_X Control the clock phase of CLKVDOX pin (default = 0, 0 degree)
- ENC_CLK_PH_Y Control the clock phase of CLKVDOY pin (default = 2, 180 degree)
- DEC_CLK_PH_X Control the clock phase of CLKMPP1 pin (default = 0, 0 degree)
- DEC_CLK_PH_Y Control the clock phase of CLKMPP2 pin (default = 0, 0 degree)
- 0 None operation
- 1 None operation when clock frequency is not 13.5MHz
90 degree shift when clock frequency is 13.5MHz
- 2 180 degree Phase Inverting
- 3 180 degree Phase Inverting when clock frequency is not 13.5MHz
270 degree shift when clock frequency is 13.5MHz
-
- ENC_CLKDEL_X Control the clock delay of CLKVDOX pin
- ENC_CLKDEL_Y Control the clock delay of CLKVDOY pin
- DEC_CLKDEL_X Control the clock delay of CLKMPP1 pin
- DEC_CLKDEL_Y Control the clock delay of CLKMPP2 pin
- The delay can be controlled by 1ns.
- The default value is 0.

Index	[7]	[6]	[5]	[4]	[3]	[2]	[1]	[0]
1xB0	0	0	MPPOUT2		MPPOUT1		MPPOUT0	
1xB1	MPPSET0_MSB				MPPSET0_LSB			
1xB2	MPPDATA0_MSB				MPPDATA0_LSB			
1xB3	MPPSET1_MSB				MPPSET1_LSB			
1xB4	MPPDATA1_MSB				MPPDATA1_LSB			
1xB5	MPPSET2_MSB				MPPSET2_LSB			
1xB6	MPPDATA2_MSB				MPPDATA2_LSB			

- MPPOUT2** Select the MPP2 pin function (default= 0)
- MPPOUT1** Select the MPP1 pin function (default= 0)
- MPPOUT0** Select the DLINKI pin function (default= 0)
 In cascaded mode, DLINKI pin is reserved for cascaded operation
 0 Multi purpose output mode 1 (default)
 1 GPPIO mode
 2 Multi purpose output mode 2
- MPPSET_MSB** Select the function for MPP [7:4] pins in Multi purpose output Mod 1
 Select I/O for each bit for MPP [7:4] pins in GPPIO Mode
 Select the function for MPP [7:4] pins in Multi purpose output Mod 2 (default= 0)
- MPPSET_LSB** Select the function for MPP [3:0] pins in Multi purpose output Mod 1
 Select I/O for each bit for MPP [3:0] pins in GPPIO Mode
 Select the function for MPP [3:0] pins in Multi purpose output Mod 2 (default= 0)
 The detailed description for each mode is shown in following table
- MPPDATA_MSB** In writing mode, the data is for MPP [7:4] in GPPIO mode
 In reading mode, the data stands for MPP [7:4] pin status (default= 0)
- MPPDATA_LSB** In writing mode, the data is for MPP [3:0] in GPPIO mode
 In reading mode, the data stands for MPP [3:0] pin status (default= 0)

MPP_MD	MPP_SET	I/O	MPP_DATA	Remark
0	0	In	Input Data from Pin	Default
	1	Out	STROBE_DET_C	Capture path
	2		CHID_MUX[3:0]	
	3		CHID_MUX[7:4]	
	4		MUX_OUT_DET[15:12]	
	5 – 7		-	
	8	STROBE_DET_D	Display Path	
	9 – 13	-	Reserved	
	14	{1'b0, H, V, F}	BT. 656 Sync	
	15	{hsync, vsync, field, link}	Analog Encoder Sync	
1	0	Out	Write Data to Pin	GPP I/O Mode
	1	In	Input Data from Pin	
2	0	Out	Decoder H Sync	Bit[3:0] : VIN3 ~ VIN0
	1		Decoder V Sync	
	2		Decoder Field Sync	
	3		Decoder Ch 0/1 [7:4]	MSB for Ch 0/1
	4		Decoder Ch 0/1 [3:0]	LSB for Ch 0/1
	5		Decoder Ch 2/3 [7:4]	MSB for Ch 2/3
	6		Decoder Ch 2/3 [3:0]	LSB for Ch 2/3
	7		-	Reserved
	8		NOVID_DET_M	For VINA (ANA_SW = 0)
	9		MD_DET_M	
	10		BD_DET_M	
	11		ND_DET_M	For VINB (ANA_SW = 1)
	12		NOVID_DET_S	
	13		MD_DET_S	
	14		BD_DET_S	
15	ND_DET_S			

Index	[7]	[6]	[5]	[4]	[3]	[2]	[1]	[0]
1xB7					00			
1xB8					00			
1xB9					00			
1xBA					00			
1xBB					00			
1xBC					00			
1xBD					00			
1xBE					00			
1xBF					00			

This is reserved register.

For normal operation, the above value should be set in this register.

Index	[7]	[6]	[5]	[4]	[3]	[2]	[1]	[0]
2x00	OSD_BUF_DATA[31:24]							
2x01	OSD_BUF_DATA[23:16]							
2x02	OSD_BUF_DATA[15:8]							
2x03	OSD_BUF_DATA[7:0]							
2x04	OSD_BUF_WR	OSD_BUF_RD	0		OSD_BUF_ADDR			

- OSD_BUF_DATA** Define the writing data of OSD buffer (Internal Buffer Size = 32Bit x 16) in normal single writing mode
 Define the OSD acceleration data in acceleration downloading mode (default = 0)
 [31:24] is left top font from 4 OSD dot in display path
 [31:28] is left top font from 8 OSD dot in capture path
 Read mode depends on OSD_BUF_RD
 0 Read the buffer data with OSD_BUF_ADDR (default)
 1 Read the OSD acceleration downloading data
- OSD_BUF_WR** Request to write the OSD internal buffer
 This bit is cleared automatically after downloading is finished
 0 Disable the writing or Writing is finished (default)
 1 Enable the writing
- OSD_BUF_ADDR** Select the OSD internal buffer address to read/write
 0 0 internal buffer address (default)
 : :
 Table 1 15 internal buffer address

Index	[7]	[6]	[5]	[4]	[3]	[2]	[1]	[0]
2x05	OSD_START_HPOS							
2x06	OSD_END_HPOS							
2x07	OSD_START_VPOS[7:0]							
2x08	OSD_END_VPOS[7:0]							
2x09					OSD_START_VPOS[9:8]		OSD_END_VPOS[9:8]	

OSD_START_HPOS Define the horizontal starting position in normal single writing mode
 Define the horizontal starting position in acceleration downloading mode
 For display path, 4 pixel per unit
 0 1 pixel (default)
 : :
 179 716 pixel

For record path, 8 pixel per unit
 0 1 pixel
 : :
 Table 1 712 pixel

OSD_END_HPOS Define the horizontal end position in acceleration wiring mode (default = 0)
 Same unit as the OSD_START_HPOS

OSD_START_VPOS Define the vertical starting position in normal single writing mode
 Define the vertical starting position in acceleration downloading mode
 Bit [9] stands for writing field
 0 Odd field (default)
 1 Even field
 Bit [8:0] stands for writing line number
 0 1 Line (default)
 : :
 239 240 Line for 60Hz system
 : :
 Table 1 288 Line for 50Hz system

OSD_END_VPOS Define the vertical end position in acceleration downloading mode
 (default = 0)
 The unit is same as the OSD_START_VPOS

Index	[7]	[6]	[5]	[4]	[3]	[2]	[1]	[0]
2x09	BUF_WR_SIZE							
2x0A	OSD_MEM_WR	OSD_ACC_EN	OSD_MEM_PATH	OSD_PAGE_D			0	INDEX_RD_MD

BUF_WR_SIZE Define the buffer downloading size in normal single writing mode
 0 32 Bit X 1 (default)
 : :
 Table 1 32 Bit X 16

OSD_MEM_WR Enable to write the OSD into memory.
 This bit is cleared automatically after downloading is finished
 0 Disable the writing or Writing is finished (default)
 1 Enable the writing

OSD_ACC_EN Select the OSD writing mode
 0 Normal single writing mode using internal buffer (default)
 1 Acceleration downloading mode

OSD_MEM_PATH Select the OSD writing Path
 0 Display path (default)
 1 Record path

OSD_WR_PAGE Select OSD writing page for display path
 0 Page = 0 (default)
 : :
 Table 1 Page = 5
 6/7 Not allowed

Index	[7]	[6]	[5]	[4]	[3]	[2]	[1]	[0]
2x0B	OSD_INDEX_Y							
2x0C	OSD_INDEX_CB							
2x0D	OSD_INDEX_CR							
2x0E	OSD_INDEX_WR	OSD_INDEX_ADDR						

OSD_INDEX_Y Y component for Color Look-Up Table (default = 0)
 OSD_INDEX_CB Cb component for Color Look-Up Table (default = 0)
 OSD_INDEX_CR Cr component for Color Look-Up Table (default = 0)
 OSD_INDEX_WR Request to write the Color Look-Up Table
 This register is cleared automatically after downloading is finished
 0 Disable the writing or Writing is finished (default)
 1 Enable the Writing

OSD_INDEX_ADDR Define the OSD index address for Color Look-Up Table
 0 0 index of LUT for display path (default)
 : :
 63 63 index of LUT for display path
 64 0 index of LUT for capture path
 : :
 67 3 index of LUT for capture path
 68- Not allowed

Index	[7]	[6]	[5]	[4]	[3]	[2]	[1]	[0]
2x0F	0	OSD_RD_PAGE_X			OSD_FLD_X		OSD_FLD_Y	

OSD_RD_PAGE_X Select the OSD reading page for display path
 0 Page = 0 (default)
 : :
 Table 1 Page = 5
 6/7 Not allowed

OSD_FLD Enable the bitmap overlay
 0 Disable the bitmap overlay (default)
 1 Enable the bitmap overlay with even field display RAM
 2 Enable the bitmap overlay with odd field display RAM
 3 Enable the bitmap overlay with both odd and even field display RAM

Index	[7]	[6]	[5]	[4]	[3]	[2]	[1]	[0]
2x10	CUR_ON_X	CUR_ON_Y	CUR_TYPE	CUR_SUB	CUR_BLINK	0	CUR_HP[0]	CUR_VP[0]
2x11	CUR_HP[8:1]							
2x12	CUR_VP[8:1]							

- CUR_ON** Enable the mouse pointer.
 0 Disable mouse pointer (default)
 1 Enable mouse pointer
- CUR_TYPE** Select the mouse type
 0 Small mouse pointer (default)
 1 Large mouse pointer
- CUR_SUB** Control inside style of mouse pointer.
 0 Transparent (default)
 1 Filled with white color
- CUR_BLINK** Enable blink of mouse pointer.
 0 Disable blink (default)
 1 Enable blink with 0.5 second period
- CUR_HP** Control the horizontal location of mouse pointer.
 0 0 Pixel position (default)
 : :
 360 720 Pixel position
- CUR_VP** Control the vertical location of mouse pointer.
 0 0 Line position (default)
 : :
 Table 1 288 Line position

Index	[7]	[6]	[5]	[4]	[3]	[2]	[1]	[0]
2x13								CLUT0_Y
2x14								CLUT0_CB
2x15								CLUT0_CR
2x16								CLUT1_Y
2x17								CLUT1_CB
2x18								CLUT1_CR
2x19								CLUT2_Y
2x1A								CLUT2_CB
2x1B								CLUT2_CR
2x1C								CLUT3_Y
2x1D								CLUT3_CB
2x1E								CLUT3_CR

CLUT0_Y	Y component for user defined color 0 (default : 0)
CLUT0_CB	Cb component for user defined color 0 (default : 0)
CLUT0_CR	Cr component for user defined color 0 (default : 0)
CLUT1_Y	Y component for user defined color 1 (default : 0)
CLUT1_CB	Cb component for user defined color 1 (default : 0)
CLUT1_CR	Cr component for user defined color 1 (default : 0)
CLUT2_Y	Y component for user defined color 2 (default : 0)
CLUT2_CB	Cb component for user defined color 2 (default : 0)
CLUT2_CR	Cr component for user defined color 2 (default : 0)
CLUT3_Y	Y component for user defined color 3 (default : 0)
CLUT3_CB	Cb component for user defined color 3 (default : 0)
CLUT3_CR	Cr component for user defined color 3 (default : 0)

Index	[7]	[6]	[5]	[4]	[3]	[2]	[1]	[0]
2x1F	TBLINK_OSD		ALPHA_OSD		ALPHA_2DBOX		ALPHA_BOX	

TBLINK_OSD Select the blink time for bitmap overlay

- 0 0.25 sec (default)
- 1 0.5 sec
- 2 1 sec
- 3 2 sec

ALPHA_OSD Select the alpha blending mode for bitmap overlay

- 0 50% (default)
- 1 50%
- 2 75%
- 3 25%

ALPHA_2DBOX Select the alpha blending mode for 2D arrayed Box

- 0 50% (default)
- 1 50%
- 2 75%
- 3 25%

ALPHA_BOX Select the alpha blending mode for Single Box

- 0 50% (default)
- 1 50%
- 2 75%
- 3 25%

Box	Index	[7]	[6]	[5]	[4]	[3]	[2]	[1]	[0]
B0	2x20	BOX_BND_COL		BOX_PLNMIX_Y	BOX_BNDEN_Y	BOX_PLNEN_Y	BOX_PLNMIX_X	BOX_BNDEN_X	BOX_PLNEN_X
B1	2x26								
B2	2x2B								
B3	2x32								

BOX_BND_COL Define the box boundary color for each box

- 0 0% White (Default)
- 1 25% White
- 2 50% White
- 3 75% White

BOX_PLNMIX_Y Enable the alpha blending for box plane area in record path

- 0 No alpha blending (Default)
- 1 Enable alpha blending

BOX_BNDEN_Y Enable the box boundary in record path

- 0 Disable (Default)
- 1 Enable

BOX_PLNEN_Y Enable the box plane area in record path

- 0 Disable (Default)
- 1 Enable

BOX_PLNMIX_X Enable the alpha blending of box plane area in display path

- 0 No alpha blending (Default)
- 1 Enable alpha blending

BOX_BNDEN_X Enable the box boundary in display path

- 0 Disable (Default)
- 1 Enable

BOX_PLNEN_X Enable the box plane area in display path

- 0 Disable (Default)
- 1 Enable

Box	Index	[7]	[6]	[5]	[4]	[3]	[2]	[1]	[0]
B0	2x21	BOX_PLNCOL							
B1	2x27								
B2	2x2C								
B3	2x33								

BOX_PLNCOL

Define the box plane color for each box

- 0 White (75% Amplitude 100% Saturation) (default)
- 1 Yellow (75% Amplitude 100% Saturation)
- 2 Cyan (75 % Amplitude 100 Saturation)
- 3 Green (75% Amplitude 100% Saturation)
- 4 Magenta (75% Amplitude 100% Saturation)
- 5 Red (75% Amplitude 100% Saturation)
- 6 Blue (75% Amplitude 100% Saturation)
- 7 0% Black
- 8 100% White
- 9 50% Gray
- 10 25% Gray
- 11 Blue (75% Amplitude 75% Saturation)
- 12 Defined by CLUT0
- 13 Defined by CLUT1
- 14 Defined by CLUT2
- 15 Defined by CLUT3

Box	Index	[7]	[6]	[5]	[4]	[3]	[2]	[1]	[0]
B0	2x21								
B1	2x27								
B2	2x2C								
B3	2x33								
B0	2x22	BOXHL[8:1]							
B1	2x28								
B2	2x2D								
B3	2x34								

BOX_HL Define the horizontal left location of box.
 0 Left end (default)
 : :
 Table 1 Right end

Box	Index	[7]	[6]	[5]	[4]	[3]	[2]	[1]	[0]
B0	2x21								
B1	2x27								
B2	2x2C								
B3	2x33								
B0	2x23	BOXHW[8:1]							
B1	2x29								
B2	2x2E								
B3	2x35								

BOX_HW Define the horizontal size of box.
 0 0 Pixel width (default)
 : :
 Table 1 720 Pixels width

Box	Index	[7]	[6]	[5]	[4]	[3]	[2]	[1]	[0]
B0	2x21							BOXVT[0]	
B1	2x27								
B2	2x2C								
B3	2x33								
B0	2x24	BOXVT[8:1]							
B1	2x2A								
B2	2x2F								
B3	2x36								

BOX_VT Define the vertical top location of box.
 0 Vertical top (default)
 : :
 Table 1 Vertical bottom

Box	Index	[7]	[6]	[5]	[4]	[3]	[2]	[1]	[0]
B0	2x21								BOXVW[0]
B1	2x27								
B2	2x2C								
B3	2x33								
B0	2x25	BOXVW[8:1]							
B1	2x2B								
B2	2x30								
B3	2x37								

BOX_VW Define the vertical size of box.
 0 0 Lines height (default)
 : :
 Table 1 288 Lines height

Index	[7]	[6]	[5]	[4]	[3]	[2]	[1]	[0]
2x38	0		0		OSD_OVL_MD_D		OSD_OVL_MD_C	

OSD_OVL_MD Control the OSD overlay mode for each path
 0 No overlay (default)
 1 Enable overlay with high priority
 2 Enable overlay with low priority
 3 Enable overlay with no priority

2DBox	Index	[7]	[6]	[5]	[4]	[3]	[2]	[1]	[0]
2DB0	2x5B	MDAREA_COL				DETAREA_COL			
2DB1	2x5C								
2DB2	2x5D								
2DB3	2x5E								
2x5F		MDBND3_COL	MDBND2_COL	MDBND1_COL	MDBND0_COL				

MDAREA_COL Define the color of Mask plane in 2D arrayed box. (default = 0)

DETAREA_COL Define the color of Detection plane in 2D arrayed box. (default = 0)

- 0 White (75% Amplitude 100% Saturation)
- 1 Yellow (75% Amplitude 100% Saturation)
- 2 Cyan (75 % Amplitude 100 Saturation)
- 3 Green (75% Amplitude 100% Saturation)
- 4 Magenta (75% Amplitude 100% Saturation)
- 5 Red (75% Amplitude 100% Saturation)
- 6 Blue (75% Amplitude 100% Saturation)
- 7 0% Black
- 8 100% White
- 9 50% Gray
- 10 25% Gray
- 11 Blue (75% Amplitude 75% Saturation)
- 12 Defined by CLUT0
- 13 Defined by CLUT1
- 14 Defined by CLUT2
- 15 Defined by CLUT3

MDBND_COL Define the color of 2D arrayed box boundary

- 0 0 % Black (default)
- 1 25% Gray
- 2 50% Gray
- 3 75% White

Define the displayed color for cursor cell and motion-detected region

- 0,1 75% White (default)
- 2,3 0% Black

2Dbox	Index	[7]	[6]	[5]	[4]	[3]	[2]	[1]	[0]
2DB0	2x60	2DBOX _EN_X	2DBOX _EN_Y	2DBOX _MODE	2DBOX_ CUREN	2DBOX _MIX	2DBOX_IN_SEL		
2DB1	2x68								
2DB2	2x70								
2DB3	2x78								

- 2DBOX_EN** Enable the 2Dbox
 0 Disable the 2D box (default)
 1 Enable the 2D box
- 2DBOX_MODE** Define the operation mode of 2D arrayed box.
 0 Table mode (default)
 1 Motion display mode
- 2DBOX_CUREN** Enable the cursor cell inside 2D arrayed box.
 0 Disable the cursor cell (default)
 1 Enable the cursor cell
- 2DBOX_MIX** Enable the alpha blending for 2D arrayed box plane with video data.
 0 Disable the alpha blending (default)
 1 Enable the alpha blending with ALPHA_2DBOX setting (2x03)
- 2DBOX_IN_SEL** Select the input for Mask / Detection data of 2D Box.
 0 Mask and Detection Data for VIN 0 and ANA_SW = 0 (default)
 1 Mask and Detection Data for VIN1 and ANA_SW = 0
 2 Mask and Detection Data for VIN 2 and ANA_SW = 0
 3 Mask and Detection Data for VIN 3 and ANA_SW = 0
 4 Mask and Detection Data for VIN 0 and ANA_SW = 1
 5 Mask and Detection Data for VIN1 and ANA_SW = 1
 6 Mask and Detection Data for VIN 2 and ANA_SW = 1
 7 Mask and Detection Data for VIN 3 and ANA_SW = 1

2Dbox	Index	[7]	[6]	[5]	[4]	[3]	[2]	[1]	[0]
2DB0	2x61	2DBOX_ HINV	2DBOX_ VINV	2DBOX_ MSKEN	2DBOX_ DETEN	2DBOX_ BNDEN	0		
2DB1	2x69								
2DB2	2x71								
2DB3	2x79								

- 2DBOX_HINV** Enable the horizontal mirroring for 2D arrayed box.
 0 Normal operation (default)
 1 Enable the horizontal mirroring
- 2DBOX_VINV** Enable the vertical mirroring for 2D arrayed box.
 0 Normal operation (default)
 1 Enable the vertical mirroring
- 2DBOX_DETEN** Enable the detection plane of 2D arrayed box.
 When 2DBOX_MODE = "0"
 0 Disable the detection plane of 2D arrayed box (default)
 1 Enable the detection plane of 2D arrayed box
- When 2DBOX_MODE = "1"
 0 Display the motion detection result with inner boundary
 1 Display the motion detection result with plane
- 2DBOX_MSKEN** Enable the mask plane of 2D arrayed box.
 0 Disable the mask plane of 2D arrayed box (default)
 1 Enable the mask plane of 2D arrayed box
- 2DBOX_BNDEN** Enable the boundary of 2D arrayed box.
 0 Disable the boundary (default)
 1 Enable the boundary

2Dbox	Index	[7]	[6]	[5]	[4]	[3]	[2]	[1]	[0]
2DB0	2x61							2DBOX_HL[0]	
2DB1	2x69								
2DB2	2x71								
2DB3	2x79								
2DB0	2x62	2DBOX_HL[8:1]							
2DB1	2x6A								
2DB2	2x72								
2DB3	2x7A								

2DBOX_HL Define the horizontal left location of 2D arrayed box.
 0 Horizontal left end (default)
 : :
 Table 1 Horizontal right end

2Dbox	Index	[7]	[6]	[5]	[4]	[3]	[2]	[1]	[0]
2DB0	2x63	2DBOX_HW							
2DB1	2x6B								
2DB2	2x73								
2DB3	2x7B								

2DBOX_HW Define the horizontal size of 2D arrayed box.
 0 0 Pixel width (default)
 : :
 Table 1 510 Pixels width

2Dbox	Index	[7]	[6]	[5]	[4]	[3]	[2]	[1]	[0]	
2DB0	2x61								2DBOX_VT[0]	
2DB1	2x69									
2DB2	2x71									
2DB3	2x79									
2DB0	2x64	2DBOX_VT[8:1]								
2DB1	2x6C									
2DB2	2x74									
2DB3	2x7C									

2DBOX_VT Define the vertical top location of 2D arrayed box.
 0 Vertical top end (default)
 : :
 240 Vertical bottom end for 60Hz system
 : :
 Table 1 Vertical bottom end for 50Hz system

2Dbox	Index	[7]	[6]	[5]	[4]	[3]	[2]	[1]	[0]
2DB0	2x65	2DBOX_VW							
2DB1	2x6D								
2DB2	2x75								
2DB3	2x7D								

2DBOX_VW Define the vertical size of 2D arrayed box.
 0 0 Line height (default)
 : :
 Table 1 255 Line height

2Dbox	Index	[7]	[6]	[5]	[4]	[3]	[2]	[1]	[0]
2DB0	2x66	2DBOX_HNUM				2DBOX_VNUM			
2DB1	2x6E								
2DB2	2x76								
2DB3	2x7E								

2DBOX_VNUM Define the row number of 2D arrayed box.
 For motion display mode, 11 is recommended.
 0 1 Row
 : :
 11 12 Row (default)
 : :
 Table 1 16 Rows

2DBOX_HNUM Define the column number of 2D arrayed box.
 For motion display mode, 15 is recommended.
 0 1 Column
 : :
 Table 1 16 Columns (default)

2Dbox	Index	[7]	[6]	[5]	[4]	[3]	[2]	[1]	[0]
2DB0	2x67	2DBOX_CURHP				2DBOX_CURVP			
2DB1	2x6F								
2DB2	2x77								
2DB3	2x7F								

2DBOX_CURHP Define the horizontal location of cursor cell within 2DBOX_HNUM.
 0 1st Column (default)
 : :
 Table 1 16th Column

2DBOX_CURVP Define the vertical location of cursor cell within 2DBOX_VNUM.
 0 1st Row (default)
 : :
 Table 1 16th Row

VIN	Index	[7]	[6]	[5]	[4]	[3]	[2]	[1]	[0]
0	2x80	MD_DIS	MD_REFFLD	BD_CELSENS			BD_LVSENS		
1	2xA0								
2	2xC0								
3	2xE0								
0	2x81	ND_LVSENS				ND_TMPSENS			
1	2xA1								
2	2xC1								
3	2xE1								

- MD_DIS** Disable the motion and blind detection.
 0 Enable motion and blind detection (default)
 1 Disable motion and blind detection
- MD_REFFLD** Control the updating time of reference field for motion detection.
 0 Update reference field every field (default)
 1 Update reference field according to MD_SPEED
- BD_CELSENS** Define the threshold of cell for blind detection.
 0 Low threshold (More sensitive) (default)
 : :
 3 High threshold (Less sensitive)
- BD_LVSENS** Define the threshold of level for blind detection.
 0 Low threshold (More sensitive) (default)
 : :
 15 High threshold (Less sensitive)
- ND_LVSENS** Define the threshold of level for night detection.
 0 Low threshold (More sensitive) (default)
 : :
 3 High threshold (Less sensitive)
- ND_TMPSENS** Define the threshold of temporal sensitivity for night detection.
 0 Low threshold (More sensitive) (default)
 : :
 Table 1 High threshold (Less sensitive)

VIN	Index	[7]	[6]	[5]	[4]	[3]	[2]	[1]	[0]
0	2x82	MD_MASK_RD_MD		MD_FLD					MD_ALGIN
1	2xA2								
2	2xC2								
3	2xE2								
0	2x83	MD_CELSENS		MD_DUAL_EN					MD_LVSENS
1	2xA3								
2	2xC3								
3	2xE3								

MD_MASK_RD_MD Select the read mode of MD_MASK register

- 0 Read motion detection information when ANA_SW = 0
- 1 Read motion detection information when ANA_SW = 1
- 2/3 Read the mask information

MD_FLD Select the field for motion detection.

- 0 Detecting motion for only odd field (default)
- 1 Detecting motion for only even field
- 2 Detecting motion for any field
- 3 Detecting motion for both odd and even field

MD_ALGIN Adjust the horizontal starting position for motion detection.

- 0 0 pixel (default)
- : :
- 15 15 pixels

MD_CELSENS Define the threshold of sub-cell number for motion detection.

- 0 Motion is detected if 1 sub-cell has motion (More sensitive) (default)
- 1 Motion is detected if 2 sub-cells have motion
- 2 Motion is detected if 3 sub-cells have motion
- 3 Motion is detected if 4 sub-cells have motion (Less sensitive)

MD_DUAL_EN Enable the non-realtime motion detection mode

- 0 Normal 4 channel motion detection mode (default)
- 1 8 channel detection mode for non-realtime application

MD_LVSENS Control the level sensitivity of motion detector.

- 0 More sensitive (default)
- : :
- Table 1 Less sensitive

VIN	Index	[7]	[6]	[5]	[4]	[3]	[2]	[1]	[0]
0	2x84	MD_STRB_EN	MD_STRB	MD_SPEED					
1	2xA4								
2	2xC4								
3	2xE4								
0	2x85	MD_TMPSENS				MD_SPSSENS			
1	2xA5								
2	2xC5								
3	2xE5								

- MD_STRB_EN** Select the trigger mode of motion detection
 0 Automatic trigger mode of motion detection (default)
 1 Manual trigger mode for motion detection
- MD_STRB** Request to start motion detection on manual trigger mode
 0 None Operation (default)
 1 Request to start motion detection
- MD_SPEED** Control the velocity of motion detector.
 Large value is suitable for slow motion detection.
 In MD_DUAL_EN = 1, MD_SPEED should be limited to 0 ~ 31.
 0 1 field intervals (default)
 1 2 field intervals
 : :
 61 62 field intervals
 62 63 field intervals
 63 Not supported
- MD_TMPSENS** Control the temporal sensitivity of motion detector.
 0 More Sensitive (default)
 : :
 15 Less Sensitive
- MD_SPSSENS** Control the spatial sensitivity of motion detector.
 0 More Sensitive (default)
 : :
 Table 1 Less Sensitive

Row	Index				Motion Detection Mask Control for VIN							
	VIN0	VIN1	VIN2	VIN3	[7]	[6]	[5]	[4]	[3]	[2]	[1]	[0]
1	2x86	2xA6	2xC6	2xE6	MD_MASK[15:8]							
2	2x88	2xA8	2xC8	2xE8								
3	2x8A	2xAA	2xCA	2xEA								
4	2x8C	2xAC	2xCC	2xEC								
5	2x8E	2xAE	2xCE	2xEE								
6	2x90	2xB0	2xD0	2xF0								
7	2x92	2xB2	2xD2	2xF2								
8	2x94	2xB4	2xD4	2xF4								
9	2x96	2xB6	2xD6	2xF6								
10	2x98	2xB8	2xD8	2xF8								
11	2x9A	2xBA	2xDA	2xFA								
12	2x9C	2xBC	2xDC	2xFC								
1	2x87	2xA7	2xC7	2xE7	MD_MASK[7:0]							
2	2x89	2xA9	2xC9	2xE9								
3	2x8B	2xAB	2xCB	2xEB								
4	2x8D	2xAD	2xCD	2xED								
5	2x8F	2xAF	2xCF	2xEF								
6	2x91	2xB1	2xD1	2xF1								
7	2x93	2xB3	2xD3	2xF3								
8	2x95	2xB5	2xD5	2xF5								
9	2x97	2xB7	2xD7	2xF7								
10	2x99	2xB9	2xD9	2xF9								
11	2x9B	2xBB	2xDB	2xFB								
12	2x9D	2xBD	2xDD	2xFD								

MD_MASK

Define the motion Mask/Detection cell for VIN

MD_MASK[15] is right end and MD_MASK[0] is left end of column.

In writing mode

- 0 Non-masking cell for motion detection (default)
- 1 Masking cell for motion detection

In reading mode when MASK_MODE = "0"

- 0 Motion is not detected for cell
- 1 Motion is detected for cell

In reading mode when MASK_MODE = "1"

- 0 Non-masked cell
- 1 Masked cell

VIN	Index	[7]	[6]	[5]	[4]	[3]	[2]	[1]	[0]
0	2x9E	DET_RESULT_S*				DET_RESULT_M*			
1	2xBE								
2	2xDE								
3	2xFE								

Notes “*” stand for read only register

- DET_RESULT_S Detection result for Video Input with ANA_SW = 1
- DET_RESULT_M Detection result for Video Input with ANA_SW = 0
- Bit[3] stand for video loss detection result
- Bit[2] stand for motion detection result
- Bit[1] stand for blind detection result
- Bit[0] stand for night detection result
- 0 Video Enable / No Motion / No Blind / Day
- 1 Video Loss/ Motion / Blind / Night

Parametric Information

DC Electrical Parameters

Table 14 Absolute Maximum Ratings

Parameter	Symbol	Min	Typ	Max	Units
VDDADC (measured to VSSADC)	VDD _{ADCM}	-0.5		2.3	V
VDDDAC (measured to VSSDAC)	VDD _{DACM}	-0.5		2.3	V
VDDI (measured to VSSI)	VDD _{IM}	-0.5		2.3	V
VDDO (measured to VSSO)	VDD _{OM}	-0.5		4.5	V
Voltage on Any Digital Data Pin (See the note below)	-	-0.5		4.5	V
Analog Input Voltage for ADC		-0.5		2.0	V
Storage Temperature	T _S	-65		150	° C
Junction Temperature	T _J	0		125	° C
Vapor Phase Soldering (15 Seconds)	T _{VSOL}			220	° C

NOTE: Long-term exposure to absolute maximum ratings may affect device reliability, and permanent damage may occur if operate exceeding the rating. The device should be operated under recommended operating condition.

Table 15 Recommended Operating Conditions

Parameter	Symbol	Min	Typ	Max	Units
VDDADC (measured to VSSADC)	VDD _{ADC}	1.62	1.8	1.98	V
VDDDAC (measured to VSSDAC)	VDD _{DAC}	1.62	1.8	1.98	V
VDDI (measured to VSSI)	VDD _I	1.62	1.8	1.98	V
VDDO (measured to VSSO)	VDD _O	3.0	3.3	3.6	V
Analog VIN Amplitude Range (AC coupling required)	VIN _R	0	0.5	1.0	V
Analog AIN Amplitude Range (AC coupling required)	AIN _R	0	0.5	1.0	V
Ambient Operating Temperature	T _A	-40		70	° C

Table 16 DC Characteristics

Parameter	Symbol	Min	Typ	Max	Units
Digital Inputs					
Input High Voltage (TTL)	V_{IH}	2.0		5.5	V
Input Low Voltage (TTL)	V_{IL}	-0.3		0.8	V
Input Leakage Current (@ $V_I=2.5V$ or $0V$)	I_L			± 10	μA
Input Capacitance	C_{IN}		6		pF
Digital Outputs					
Output High Voltage	V_{OH}	2.4			V
Output Low Voltage	V_{OL}			0.4	V
High Level Output Current (@ $V_{OH}=2.4V$)	I_{OH}	6.3	12.8	21.2	mA
Low Level Output Current (@ $V_{OL}=0.4V$)	I_{OL}	4.9	7.4	9.8	mA
Tri-state Output Leakage Current (@ $V_O=2.5V$ or $0V$)	I_{OZ}			± 10	μA
Output Capacitance	C_O		6		pF
Analog Pin Input Capacitance	C_A		6		pF

Table 17 Supply Current and Power Dissipation

Parameter	Symbol	Min	Typ	Max	Units
Analog Supply Current (1.8V)	I_{DDA}		150	165	mA
Digital Internal Supply Current (1.8V)	I_{DDI}		460	505	mA
Digital I/O Supply Current (3.3V)	I_{DDO}		25	27	mA
Total Power Dissipation	P_d		1.18	1.29	W

AC Electrical Parameters

Table 18 Clock Timing Parameters

Parameter	Symbol	Min	Typ	Max	Units
Delay from CLK54I to CLKVDO	1	4.7		12.5	ns
Hold from CLKVDO (27MHz) to Data	2a	17			ns
Delay from CLKVDO (27MHz) to Data	2b			21	ns
Hold from CLK54I to Data	3a	8			ns
Delay from CLK54I to Data	3b			12	ns
Setup from PBIN to PBCLK	4a	5			ns
Hold from PBCLK to PBIN	4b	5			ns

Note : Cload = 25pF.

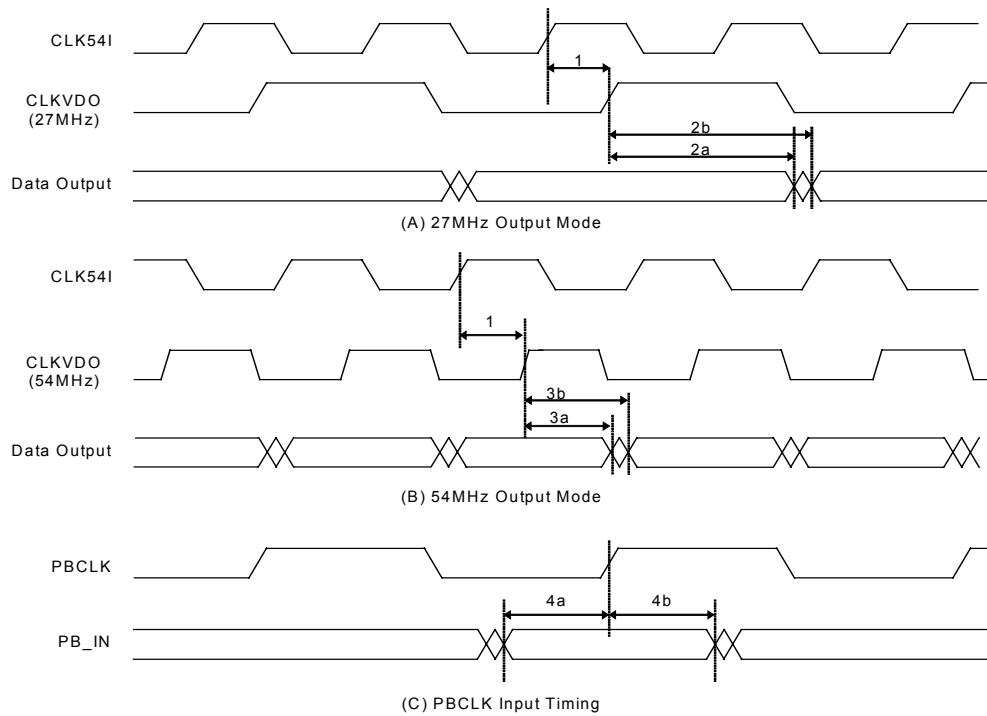

Fig 80 Clock Timing Diagram

Table 19. Serial Interface Timing

Parameter	Symbol	Min	Typ	Max	Units
Bus Free Time between STOP and START	t_{BF}	1.3			us
SDAT setup time	t_{sSDAT}	100			ns
SDAT hold time	t_{hSDAT}	0		0.9	us
Setup time for START condition	t_{sSTA}	0.6			us
Setup time for STOP condition	t_{sSTOP}	0.6			us
Hold time for START condition	t_{hSTA}	0.6			us
Rise time for SCLK and SDAT	t_R			300	ns
Fall time for SCLK and SDAT	t_F			300	ns
Capacitive load for each bus line	C_{BUS}			400	pF
SCLK clock frequency	f_{SCLK}			400	KHz

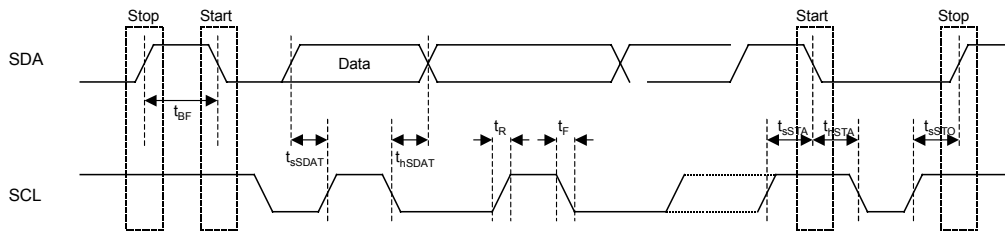

Fig 81. Serial Interface Timing Diagram

Table 20 Parallel Interface Timing Parameter

Parameter	Symbol	Min	Typ	Max	Units
CSB setup until AEN active	Tsu(1)	10			ns
PDATA setup until AEN,WENB active	Tsu(2)	10			ns
AEN, WENB, RENB active pulse width	Tw	40			ns
CSB hold after WENB, RENB inactive	Th(1)	60			ns
PDATA hold after AEN,WENB inactive	Th(2)	20			ns
PDATA delay after RENB active	Td(1)			12	ns
PDATA delay after RENB inactive	Td(2)	60			ns
CSB inactive pulse width	Tcs	60			ns
RENB active delay after AEN inactive	Trd	60			ns
RENB active delay after RENB inactive					

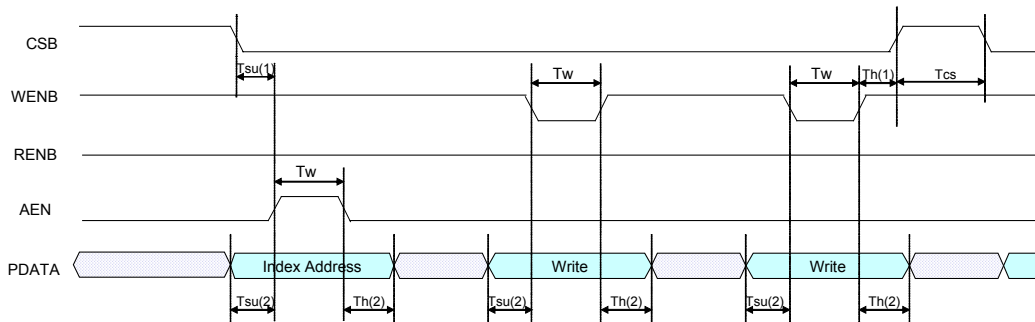

Fig 82 Write timing of parallel interface with auto index increment mode

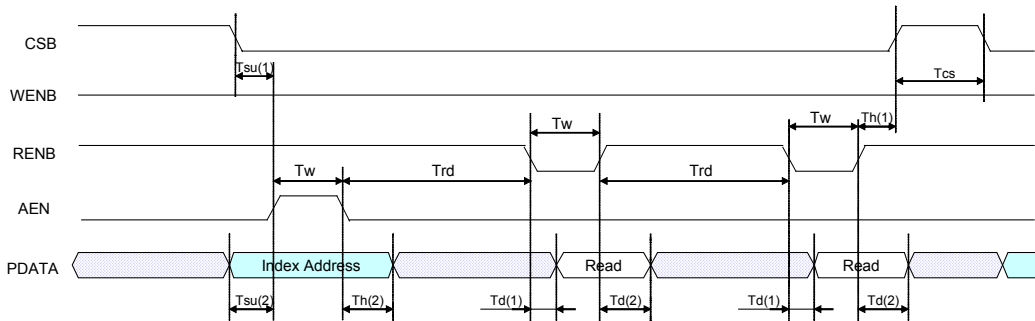

Fig 83 Read timing of parallel interface with auto index increment mode

Table 21. Analog Performance Parameter

Parameter	Symbol	Min	Typ	Max	Units
ADC characteristics					
Differential gain	D_{GA}			3	%
Differential phase	D_{pA}			2	deg
Channel Cross-talk	α_{ctA}			-50	dB
DAC characteristic					
Differential gain	D_{GD}			3	%
Differential phase	D_{pD}			2	deg
Channel Cross-talk	α_{ctA}			-50	dB

Table 22. Decoder Performance Parameter

Parameter	Symbol	Min	Typ	Max	Units
Horizontal PLL permissible static deviation	Δf_H			± 6	%
Color Sub-carrier PLL lock in range	Δf_{SC}	± 800			Hz
Video level tracking range	AGC	-6		18	dB
Color level tracking range	ACC	-6		30	dB
Oscillator Input					
Nominal frequency	f_{OSC}		54		MHz
Permissible frequency deviation	$\Delta f_{OSC}/f_{OSC}$			± 100	ppm
Duty cycle	dt_{OSC}			60	%

TW2835 Video and Audio Controller

Preliminary

Application Schematic

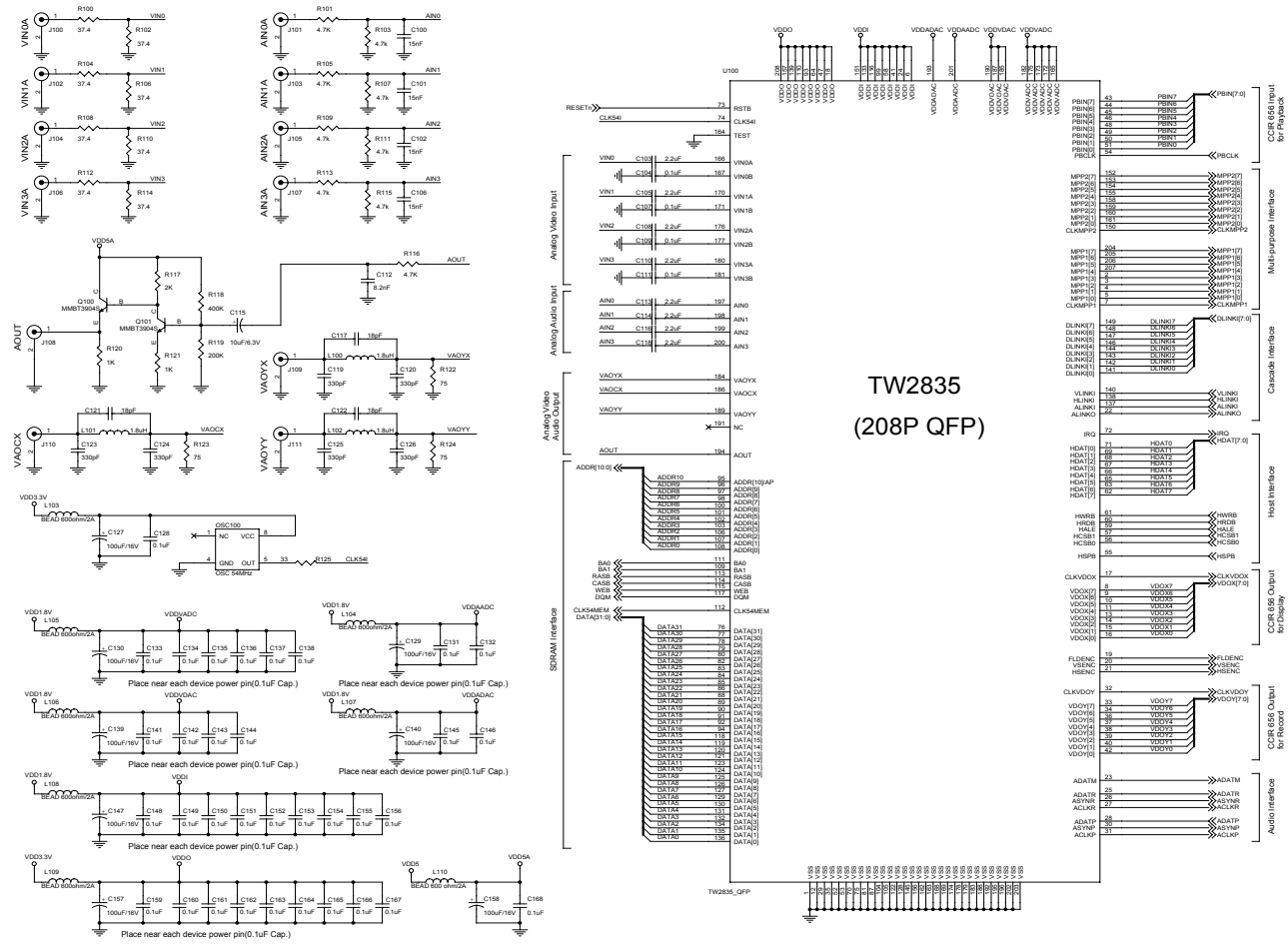

Package Dimension

208 QFP

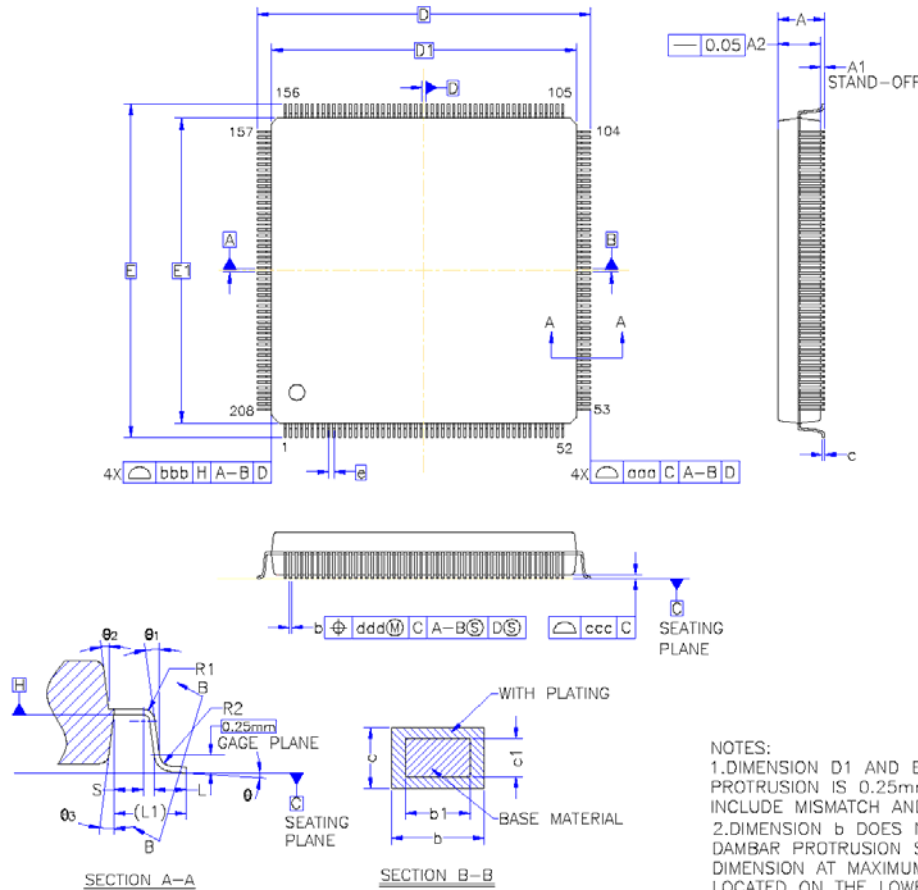

ALL DIMENSIONS ARE IN MILLIMETERS.

SYMBOL	MILLIMETER			INCH		
	MIN.	NOM.	MAX.	MIN.	NOM.	MAX.
A	—	—	4.00	—	—	0.157
A 1	0.25	0.32	0.40	0.010	0.013	0.016
A 2	3.20	3.40	3.60	0.126	0.134	0.142
D	30.60 BASIC			1.205 BASIC		
D 1	28.00 BASIC			1.102 BASIC		
E	30.60 BASIC			1.205 BASIC		
E 1	28.00 BASIC			1.102 BASIC		
R 2	0.08	—	0.25	0.003	—	0.01
R 1	0.08	—	—	0.003	—	—
Ø	0"	3.5"	8"	0"	3.5"	8"
Ø ₁	0"	—	—	0"	—	—
Ø ₂	5"	—	16"	5"	—	16"
Ø ₃	5"	—	16"	5"	—	16"
c	0.09	—	0.20	0.004	—	0.008
c 1	0.09	0.15	0.16	0.004	0.006	0.006
L 1	1.30 REF			0.052 REF		
L	0.45	0.60	0.75	0.018	0.024	0.030
S	0.20	—	—	0.008	—	—
b	0.17	—	0.27	0.007	—	0.011
b 1	0.17	0.20	0.23	0.007	0.008	0.009
e	0.50 BSC.			0.020 BSC.		
aaa	0.25			0.010		
bbb	0.20			0.008		
ccc	0.08			0.003		
ddd	0.08			0.003		

NOTES:
 1. DIMENSION D1 AND E1 DO NOT INCLUDE MOLD PROTRUSION. ALLOW PROTRUSION IS 0.25mm PER SIDE. DIMENSIONS D1 AND E1 DO INCLUDE MISMATCH AND ARE DETERMINED AT DATUM PLANE H;
 2. DIMENSION b DOES NOT INCLUDE DAMBAR PROTRUSION. ALLOWABLE DAMBAR PROTRUSION SHALL BE 0.08mm TOTAL IN EXCESS OF THE b DIMENSION AT MAXIMUM MATERIAL CONDITION. DAMBAR CANNOT BE LOCATED ON THE LOWER RADIUS OR THE LEAD FOOT;

256 LPGA

TOP VIEW

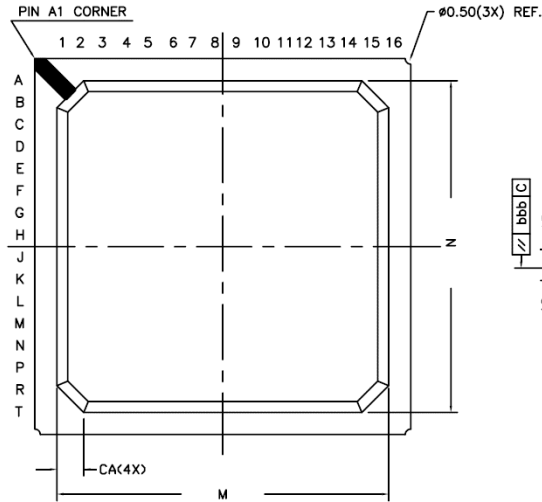

TOP VIEW

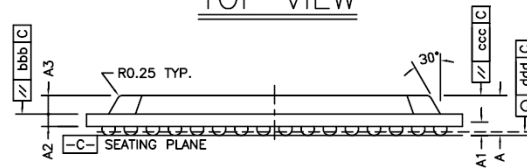

BOTTOM VIEW

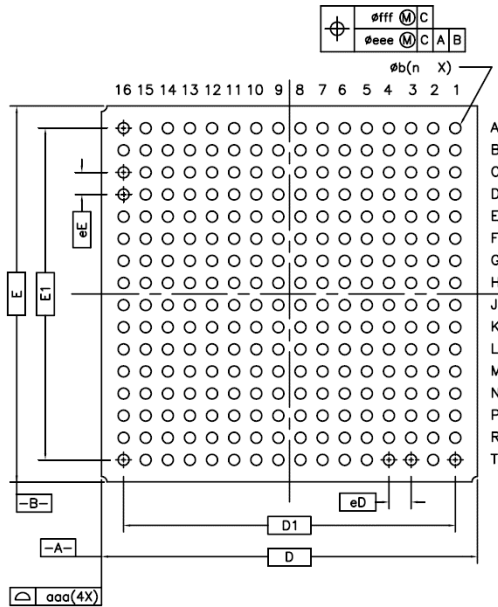

UNIT MM

	Symbol	Common Dimensions
Package :		LPGA
Body Size:	X	D 17.000
	Y	E 17.000
Ball Pitch :	X	eD 1.000
	Y	eE 1.000
Total Thickness :	A	1.810 ±0.190
Mold Thickness :	A3	0.850 Ref.
Substrate Thickness :	A2	0.560 Ref.
Ball Diameter :		0.500
Stand Off :	A1	0.300 ~ 0.500
Ball Width :	b	0.400 ~ 0.600
	X	M 15.000
Mold Area :	Y	N 15.000
	CA	1.2 Ref.
Package Edge Tolerance :	aaa	0.200
Substrate Flatness :	bbb	0.250
Mold Flatness :	ccc	0.350
Coplanarity:	ddd	0.200
Ball Offset (Package) :	eee	0.250
Ball Offset (Ball) :	fff	0.100
Ball Count :	n	256
Edge Ball Center to Center :	X	D1 15.000
	Y	E1 15.000

Revision History

Table 23 Datasheet Revision History

Revision	Date	Description	Product Code
1.0	Jul. 05. 2006	Preliminary Datasheet Release	BAPA1
1.1	Jul. 10.2006	Update the Errata 1) Update the Fig 49 ~ Fig 52 for SYNC_DEL value (P. 78 ~ P. 81) Update the register description for SYNC_DEL (P. 208) 2) Update the register description for VIS_CODE_EN (P.209) 3) Update the register description for 2DBOX_HL (P.239)	BAPA1
1.2	Oct. 10. 2006	Update the Errata 1) Update the description of noise reduction (P. 69) 2) Update the Fig 52 (P. 81) 3) Correct the register address mismatch (P.83, P.87, P.88) 4) Update the register description for NR_EN (P. 116) 5) Update the register description for MIX_OUTSEL (P.155) 6) Remove the register description for ENHANCE (P. 198) 7) Update the recommended schematic for Audio LPF filter (P.253)	BAPA1