



深圳市拓普微科技开发有限公司  
SHENZHEN TOPWAY TECHNOLOGY CO., LTD.

# TWM339AAY-1

## LCD Module User Manual

Prepared by:  <b>luolailiang</b>  Date: 2011-11-21	Checked by:    Date:	Approved by:    Date:
--	----------------------------------	-----------------------------------

Rev.	Descriptions	Release Date
0.1	New Release	2011-11-21

**Table of Content**

<b>1. Basic Specifications</b> .....	<b>3</b>
1.1 Display Specifications .....	3
1.2 Mechanical Specifications .....	3
1.3 Block Diagram .....	3
1.4 Terminal Functions .....	3
<b>2. Absolute Maximum Ratings</b> .....	<b>4</b>
<b>3. Electrical Characteristics</b> .....	<b>4</b>
3.1 DC Characteristics .....	4
3.2 LED Backlight Circuit Characteristics .....	4
3.3 AC Characteristics .....	5
<b>4. Function Specifications</b> .....	<b>6</b>
4.1 Basic Setting .....	6
4.2 Command and Data format .....	6
4.3 Addressing the LCD .....	7
4.4 Memory Map .....	7
4.5 Command Listing .....	8
<b>5. Design and Handling Precaution</b> .....	<b>9</b>

## 1. Basic Specifications

### 1.1 Display Specifications

- 1) LCD Display Mode : HTN, Positive, Transmissive
- 2) Display Color : Display Data = "1" : Black (\*1)  
: Display Data = "0" : White (\*2)
- 3) Viewing Angle : 12 H
- 4) Driving Method : 1/4 duty, 1/3 bias
- 5) Backlight : YG LED backlight

Note:

\*1. Color tone may slightly change by Temperature and Driving Condition.

\*2. The Color is defined as the inactive / background color

### 1.2 Mechanical Specifications

- 1) Outline Dimension : 246.0 x 55.88 x 13.5 MAX  
see attached Outline Drawing for details

### 1.3 Block Diagram

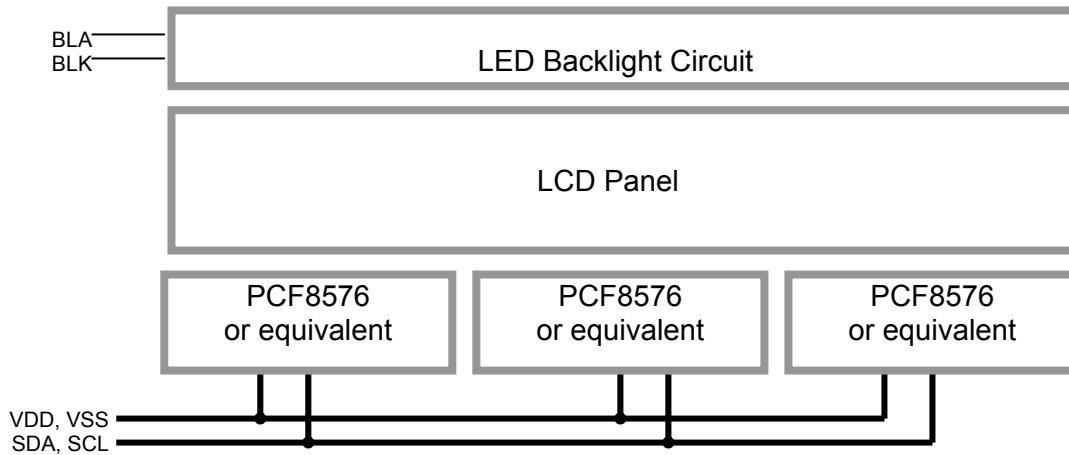

### 1.4 Terminal Functions

Pin No.	Pin Name	I/O	Descriptions
1	SDA	Input	I <sup>2</sup> C-bus data input/output
2	SCL	Input	I <sup>2</sup> C-bus serial clock input
3	VDD	Power	Positive Power Supply
4	VSS	Power	Negative Power Supply, Ground
5	BLA	Power	Backlight Positive Supply
6	BLK	Power	Backlight Negative Supply

## 2. Absolute Maximum Ratings

Items	Symbol	Min.	Max.	Unit	Condition
Supply Voltage	$V_{DD}$	-0.3	3.7	V	$V_{SS} = 0V$
Input Voltage	$V_{IN}$	$V_{SS}-0.3$	$V_{DD}+0.3$	V	$V_{SS} = 0V$
Operating Temperature	$T_{OP}$	-20	70	°C	No Condensation
Storage Temperature	$T_{ST}$	-30	80	°C	No Condensation

Cautions:

Any Stresses exceeding the Absolute Maximum Ratings may cause substantial damage to the device. Functional operation of this device at other conditions beyond those listed in the specification is not implied and prolonged exposure to extreme conditions may affect device reliability.

## 3. Electrical Characteristics

### 3.1 DC Characteristics

$V_{SS}=0V, V_{DD} =3.3V, T_{OP} =25^{\circ}C$

Items	Symbol	MIN.	TYP.	MAX.	Unit	Applicable Pin
Operating Voltage (*1)	$V_{DD}$	3.0	3.3	3.7	V	VDD
Input High Voltage	$V_{IN}$	$0.8 \times V_{DD}$	-	VDD	V	DATA, /RD, /WR, /CS
Input Low Voltage	$V_{IN}$	VSS	-	$0.2V_{DD}$	V	DATA, /RD, /WR, /CS
Operating Current	$I_{DD}$	-	0.11	2.0	mA	VDD

Note:

\*1. The variation of Operating Voltage may affect the LCD display contrast.

\*2. No Data transfer.

\*3. Exceeding the recommended driving current could cause substantial damage to the backlight and shorten its lifetime.

### 3.2 LED Backlight Circuit Characteristics

$V_{BLK}=0V, I_{f_{BLA}}=760mA, T_{OP}=25^{\circ}C$

Items	Symbol	MIN.	TYP.	MAX.	Unit	Applicable Pin
Forward Voltage	$V_{f_A}$	-	5.0	-	V	BLA, BLK
Forward Current	$I_{f_A}$	-	507	634	mA	BLA, BLK

Cautions:

Exceeding the recommended driving current could cause substantial damage to the backlight and shorten its lifetime.

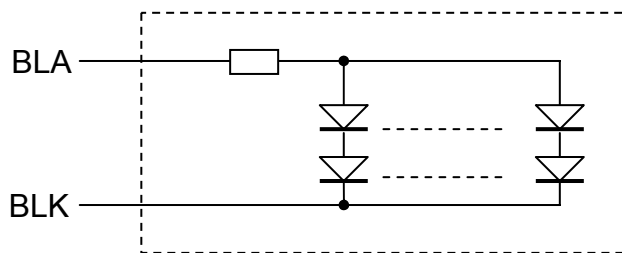

**3.3 AC Characteristics**

$V_{SS}=0V, V_{DD} =3.3V, T_{OP} =25^{\circ}C$

Symbol	MIN.	TYP.	MAX.	Unit	Descriptions
$t_{BUF}$	5.9	-	-	us	Bus free time
$t_{HD;STA}$	5.0	-	-	us	Start condition hold time
$t_{SU;STA}$	5.9	-	-	us	Set-up time for a repeated start condition
$t_{LOW}$	5.9	-	-	us	SCL low time
$t_{HIGH}$	5.0	-	-	us	SCL high time
$t_r$	-	-	0.8	us	SCL and SDA rise time
$t_f$	-	-	0.24	us	SCL and SDA fall time
$C_B$	-	-	320	pF	Capacitive bus line load
$t_{SU;DAT}$	313	-	-	ns	Data set-up time
$t_{HD;DAT}$	2	-	-	ns	Data hold time
$t_{SU;STO}$	2.0	-	-	us	Set-up time for stop condition

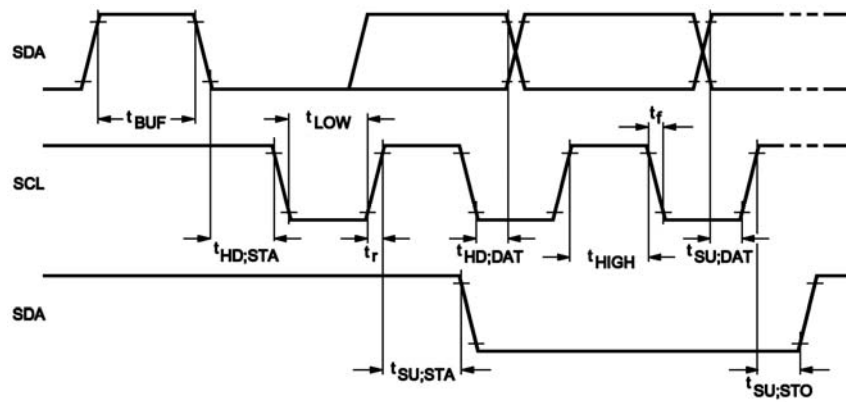

Timing Diagram

## 4. Function Specifications

### 4.1 Basic Setting

To drive the LCD module correctly and provide normally display, please use the following setting

BIAS = 1/3  
 MUX = 4BP  
 LCD Display = on

Note:  
 These setting/commands should issue to both controllers while start up.  
 See the Command Listing section for details.

### 4.2 Command and Data format

TWM339 is using I2C bus for data communication

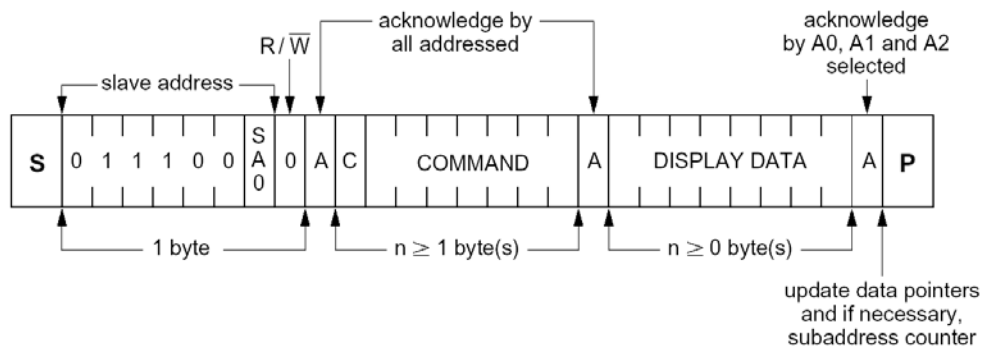

I<sup>2</sup>C-bus protocol

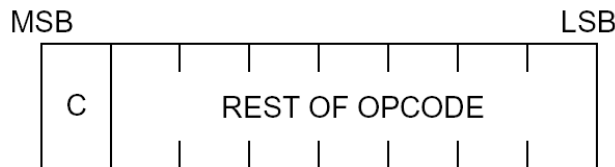

C = 0; last command.

C = 1; commands continue.

General format of command byte

For the details please refer to PCF8576C datasheet

**4.3 Addressing the LCD**

The LCD module contains three PCF8576.

Their addressed by different sub-address, 0x00,0x01,0x02

It is necessary to address each of them for command and data.

**4.4 Memory Map**

I<sup>2</sup>C Device Add=0x70, sub Add=0x00, SA0=0

Add	0x00	0x01	0x02	0x03	0x04	0x05	0x06	0x07	0x08	0x09	0x0A	0x0B	0x0C	0x0D	0x0E	0x0F	0x10	0x11	0x12	0x13
d7	1J	1I	1S	2A	2B	3J	3I	3S	4A	4B	5J	5I	5S	6A	6B	7J	7I	7S	8A	8B
d6	1L	1H	--	2P	2C	3L	3H	--	4P	4C	5L	5H	--	6P	6C	7L	7H	25Q	8P	8C
d5	1O	1K	1Q	2G	2D	3O	3K	3Q	4G	4D	5O	5K	5Q	6G	6D	7O	7K	7Q	8G	8D
d4	1N	1M	1R	2F	2E	3N	3M	3R	4F	4E	5N	5M	5R	6F	6E	7N	7M	7R	8F	8E
d3	1A	1B	2J	2I	2S	3A	3B	4J	4I	4S	5A	5B	6J	6I	6S	7A	7B	8J	8I	8S
d2	1P	1C	2L	2H	--	3P	3C	4L	4H	--	5P	5C	6L	6H	25R	7P	7C	8L	8H	25S
d1	1G	1D	2O	2K	2Q	3G	3D	4O	4K	4Q	5G	5D	6O	6K	6Q	7G	7D	8O	8K	8Q
d0	1F	1E	2N	2M	2R	3F	3E	4N	4M	4R	5F	5E	6N	6M	6R	7F	7E	8N	8M	8R

I<sup>2</sup>C Device Add=0x70, sub Add=0x01, SA0=0

Add	0x00	0x01	0x02	0x03	0x04	0x05	0x06	0x07	0x08	0x09	0x0A	0x0B	0x0C	0x0D	0x0E	0x0F	0x10	0x11	0x12	0x13
d7	9J	9I	9S	10A	10B	11J	11I	11S	12A	12B	13J	13I	13S	14A	14B	15J	15I	15S	16A	16B
d6	9L	9H	24R	10P	10C	11L	11H	24S	12P	12C	13L	13H	23Q	14P	14C	15L	15H	22R	16P	16C
d5	9O	9K	9Q	10G	10D	11O	11K	11Q	12G	12D	13O	13K	13Q	14G	14D	15O	15K	15Q	16G	16D
d4	9N	9M	9R	10F	10E	11N	11M	11R	12F	12E	13N	13M	13R	14F	14E	15N	15M	15R	16F	16E
d3	9A	9B	10J	10I	10S	11A	11B	12J	12I	12S	13A	13B	14J	14I	14S	15A	15B	16J	16I	16S
d2	9P	9C	10L	10H	24Q	11P	11C	12L	12H	23R	13P	13C	14L	14H	23S	15P	15C	16L	16H	22Q
d1	9G	9D	10O	10K	10Q	11G	11D	12O	12K	12Q	13G	13D	14O	14K	14Q	15G	15D	16O	16K	16Q
d0	9F	9E	10N	10M	10R	11F	11E	12N	12M	12R	13F	13E	14N	14M	14R	15F	15E	16N	16M	16R

I<sup>2</sup>C Device Add=0x70, sub Add=0x02, SA0=0

Add	0x00	0x01	0x02	0x03	0x04	0x05	0x06	0x07	0x08	0x09	0x0A	0x0B	0x0C	0x0D	0x0E	0x0F	0x10	0x11	0x12	0x13
d7	17J	17I	17S	18A	18B	19J	19I	19S	20A	20B	21J	21I	22J	22I	23J	23I	24J	24I	25J	25I
d6	17L	17H	22S	18P	18C	19L	19H	21Q	20P	20C	21L	21H	22L	22H	23L	23H	24L	24H	25L	25H
d5	17O	17K	17Q	18G	18D	19O	19K	19Q	20G	20D	21O	21K	22O	22K	23O	23K	24O	24K	25O	25K
d4	17N	17M	17R	18F	18E	19N	19M	19R	20F	20E	21N	21M	22N	22M	23N	23M	24N	24M	25N	25M
d3	17A	17B	18J	18I	18S	19A	19B	20J	20I	20S	21A	21B	22A	22B	23A	23B	24A	24B	25A	25B
d2	17P	17C	18L	18H	21R	19P	19C	20L	20H	21S	21P	21C	22P	22C	23P	23C	24P	24C	25P	25C
d1	17G	17D	18O	18K	18Q	19G	19D	20O	20K	20Q	21G	21D	22G	22D	23G	23D	24G	24D	25G	25D
d0	17F	17E	18N	18M	18R	19F	19E	20N	20M	20R	21F	21E	22F	22E	23F	23E	24F	24E	25F	25E

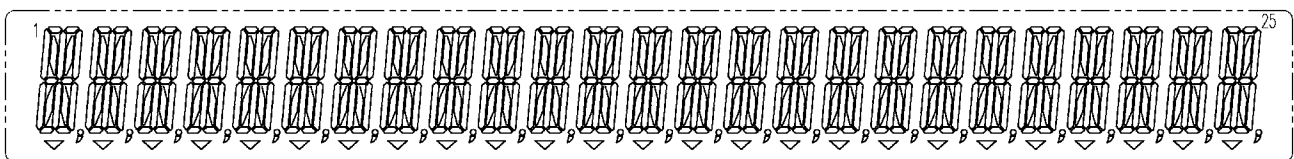

**Display Pattern**

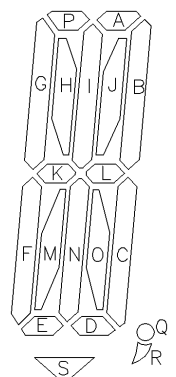

**Pattern Keys**

**4.5 Command Listing**

COMMAND	OPCODE	DESCRIPTION
MODE SET	C 1 0 LP E B M1 M0	Defines LCD drive mode.
		Defines LCD bias configuration.
		Defines display status. The possibility to disable the display allows implementation of blinking under external control.
		Defines power dissipation mode.
LOAD DATA POINTER	C 0 P5 P4 P3 P2 P1 P0	Six bits of immediate data, bits P5 to P0, are transferred to the data pointer to define one of forty display RAM addresses.
DEVICE SELECT	C 1 1 0 0 A2 A1 A0	Three bits of immediate data, bits A0 to A3, are transferred to the subaddress counter to define one of eight hardware subaddresses.
BANK SELECT	C 1 1 1 1 0 I O	Defines input bank selection (storage of arriving display data).
		Defines output bank selection (retrieval of LCD display data).
		The BANK SELECT command has no effect in 1 : 3 and 1 : 4 multiplex drive modes.
BLINK	C 1 1 1 0 A BF1 BF0	Defines the blinking frequency.
		Selects the blinking mode; normal operation with frequency set by BF1, BF0 or blinking by alternation of display RAM banks. Alternation blinking does not apply in 1 : 3 and 1 : 4 multiplex drive modes.

Mode set option 1

LCD DRIVE MODE		BITS	
DRIVE MODE	BACKPLANE	M1	M0
Static	1 BP	0	1
1 : 2	MUX (2 BP)	1	0
1 : 3	MUX (3 BP)	1	1
1 : 4	MUX (4 BP)	0	0

Mode set option 2

LCD BIAS	BIT B
1/3 bias	0
1/2 bias	1

Device select option 1

DESCRIPTION	BITS		
3 bit binary value of 0 to 7	A0	A1	A2

Bank select option 1

STATIC	1 : 2 MUX	BIT I
RAM bit 0	RAM bits 0 and 1	0
RAM bit 2	RAM bits 2 and 3	1

Bank select option 2

STATIC	1 : 2 MUX	BIT O
RAM bit 0	RAM bits 0 and 1	0
RAM bit 2	RAM bits 2 and 3	1

Mode set option 3

DISPLAY STATUS	BIT E
Disabled (blank)	0
Enabled	1

Mode set option 4

MODE	BIT LP
Normal mode	0
Power-saving mode	1

Load data pointer option 1

DESCRIPTION	BITS					
6 bit binary value of 0 to 39	P5	P4	P3	P2	P1	P0

Blink option 1

BLINK FREQUENCY	BITS	
	BF1	BF0
Off	0	0
2 Hz	0	1
1 Hz	1	0
0.5 Hz	1	1

Blink option 2

BLINK MODE	BIT A
Normal blinking	0
Alternation blinking	1

For the details please refer to PCF8576 datasheet



## 5. Design and Handling Precaution

1. The LCD panel is made by glass. Any mechanical shock (eg. dropping from high place) will damage the LCD module.
2. Do not add excessive force on the surface of the display, which may cause the Display color change abnormally.
3. The polarizer on the LCD is easily get scratched. If possible, do not remove the LCD protective film until the last step of installation.
4. Never attempt to disassemble or rework the LCD module.
5. Only Clean the LCD with Isopropyl Alcohol or Ethyl Alcohol. Other solvents (eg. water) may damage the LCD.
6. When mounting the LCD module, make sure that it is free from twisting, warping and distortion.
7. Ensure to provide enough space (with cushion) between case and LCD panel to prevent external force adding on it, or it may cause damage to the LCD or degrade the display result.
8. Only hold the LCD module by its side. Never hold LCD module by add force on the heat seal or TAB.
9. Never add force to component of the LCD module. It may cause invisible damage or degrade of the reliability.
10. LCD module could be easily damaged by static electricity. Be careful to maintain an optimum anti-static work environment to protect the LCD module.
11. When peeling off the protective film from LCD, static charge may cause abnormal display pattern. It is normal and will resume to normal in a short while.
12. Take care and prevent get hurt by the LCD panel sharp edge.
13. Never operate the LCD module exceed the absolute maximum ratings.
14. Keep the signal line as short as possible to prevent noisy signal applying to LCD module.
15. Never apply signal to the LCD module without power supply.
16. IC chip (eg. TAB or COG) is sensitive to the light. Strong lighting environment could possibly cause malfunction. Light sealing structure casing is recommend.
17. LCD module reliability may be reduced by temperature shock.
18. When storing the LCD module, avoid exposure to the direct sunlight, high humidity, high temperature or low temperature. They may damage or degrade the LCD module