

HITACHI

LIQUID CRYSTAL DISPLAY MODULE TECHNICAL DATA

TX06D103VM0AAA

CONTENTS

No.	Item	Sheet No.	Page
1	COVER	DPBCL0001404-05	1-1/1
2	RECORD OF REVISIONS	DPBCL0001404-05	2-1/1
3	GENERAL DATA	DPBCL0001404-05	3-1/1
4	ABSOLUTE MAXIMUM RATINGS	DPBCL0001404-05	4-1/1
5	ELECTRICAL CHARACTERISTICS	DPBCL0001404-05	5-1/1
6	OPTICAL CHARACTERISTICS	DPBCL0001404-05	6-1/2 - 2/2
7	BLOCK DIAGRAM	DPBCL0001404-05	7-1/1
8	INTERFACE	DPBCL0001404-05	8-1/5 - 9/9
9	DIMENSIONAL OUTLINE	DPBCL0001404-05	9-1/1

(NOTES)

1. This document may, wholly or partially, be subject to change without notice.
2. All rights are reserved ; No one is permitted to reproduce or duplicate, in any form, the whole or part of this document without Hitachi's permission.
3. No one is permitted to explain contents of this document to third parties without Hitachi's permission.
4. Hitachi will not be held responsible for any damage to the user that may result from accidents or any other reasons during operation of the user's unit according to this document, any previous reports or oral discussions.
5. Circuitry and other examples described herein are meant merely to indicate the characteristics and performance of Hitachi's products. Hitachi assumes no responsibility for any intellectual property claims or other problems that may result from applications based on the examples described herein.
6. No license is granted by implication or otherwise under any patents or other rights of any third party or Hitachi, Ltd.
7. LIFE SUPPORT APPLICATIONS : Hitachi's products are not authorized for use in LIFE SUPPORT SYSTEMS.

RECORD OF REVISIONS

Date	Sheet No.	Summary

3. GENERAL DATA

(1) Product Name	TX06D103VM0AAA
(2) Module Dimensions	42.62 (W) mm x 60.5(H) mm x 2.45 (t) mm
(3) Active Area Dimensions	36.72 (W) mm x 48.96 (H) mm
(4) Pixel Pitch	0.153 (W) mm x 0.153 (H) mm
(5) Resolution	240 x 3 (R, G, B) (W) x 320 (H) dots
(6) Color Pixel Arrangement	RGB Vertical Stripe
(7) Display Mode	Transmissive Type, Normally Black Mode, IPS
(8) Number of Colors	65,536 Colors (8-bit, 16-bit CPU - VF) 262,144 Colors (9-bit, 18-bit CPU - VF)
(9) Viewing Direction	-
(10) Backlight	Light Emitting Diode (LED) Four LEDs connected in Series
(11) Weight	12.0g
(12) Power Supply Voltage	Vcc = 2.8 V (typ)
(13) Interface I/O power supply	$1.75V \leq V_{IOVcc} \leq V_{cc}$
(14) LCD Driver IC	R61505U
(15) Interface	8-bit / 9-bit / 16-bit / 18-bit CPU bus (80 CPU series)

4. ABSOLUTE MAXIMUM RATINGS

4. 1 ELECTRICAL ABSOLUTE MAXIMUM RATINGS OF LCD

VSS = 0 V

Item	Symbol	Min	Max	Unit	Note
Power Supply for Logic and Analog	Vcc	-0.3	4.6	V	(1), (2)
Power Supply for Interface	I/OVcc	-0.3	4.6	V	(1), (2)
Input Voltage	V _{IN}	-0.3	I/OVcc+0.3	V	(1), (3)
LED Reverse Voltage	VR	-	5	V	(1), (4)
LED Forward Current	I _{LED}	-	35	mA	(4), (5)
Static Electricity	-	-	±2	kV	(6)

Notes (1) All voltage values are referred to GND.

(2) $I/OVcc \leq Vcc$

(3) Applies to the RESET*, RD*, WR*, CS*, RS, VSYNC*, IM0, IM3 and DB17-0 pins.

(4) Ta = 25 deg C, per piece of LED.

(5) Relationship between ambient temperature and allowable forward current

Allowable forward current I_F (mA)

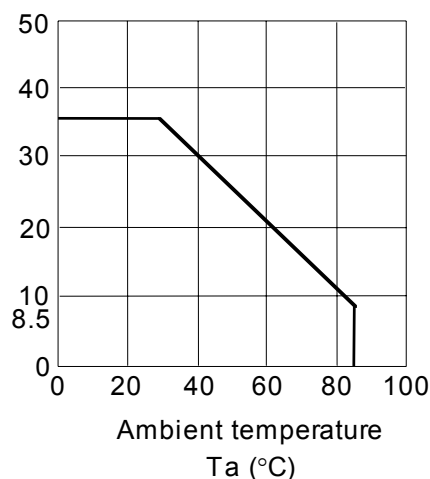

The operating current should be decided after considering the ambient maximum temperature of LEDs.

(6) 100 pF, 1.5 kohm, 25°C, 70% RH.

Static electricity discharge point is the center of LCD's surface.

4. 2 ENVIRONMENTAL ABSOLUTE MAXIMUM RATINGS

Item	Operating		Storage		Comment
	Min	Max	Min	Max	
Ambient Temperature	-20°C	70°C	-30°C	80°C	Note (2)
Humidity	Note (1)		Note (1)		No condensation
Corrosive Gas	Not Acceptable		Not Acceptable		

Notes (1) Ta ≤ 40°C: 85% RH max.

Ta > 40°C: Absolute humidity must be lower than the humidity of 85%RH at 40°C.

The polarizer quality is not assured by the above values.

(2) Background color slightly changes depending on ambient temperature and viewing angle.

5. ELECTRICAL CHARACTERISTICS

ELECTRICAL CHARACTERISTICS OF LCD

Ta = 25°C, VSS = 0 V

Item	Symbol	Condition	Min	Typ	Max	Unit	Note
Power Supply Voltage for Logic and Analog	Vcc	-	2.72	2.8	2.88	V	
Power Supply Voltage for Interface	I/OVcc	-	1.75	-	Vcc		
Input Voltage for Logic Circuits	Vi	"H" level	0.8 x I/OVcc	-	I/OVcc	V	(1)
		"L" level	0	-	0.2 x I/OVcc		
Output Voltage for Logic Circuits	Vo	"H" level	0.8 x I/OVcc	-	-	V	(2)
		"L" level	-	-	0.2 x I/OVcc		
Input/Output Leak current	ILi	-	-1.0	-	1.0	μA	
Power Supply Current	Icc	All White	-	2.5	4.0	mA	(3)
		Partial	-	1.3	2.5	mA	(4)
		Standby	-	0.1	1.0	μA	(5)
LED Forward Voltage	VLED	-	-	3.2	3.5	V	
LED Forward Current	I LED	-	-	18	Note (6)	mA/LED	
Frame Frequency	fFLM	-	-	85	-	Hz	

Notes (1) Applies to the RESET*, RD*, WR*, CS*, RS, VSYNC*, IM0, IM3 and DB17-0 pins.

(2) Applies to the FMARK and DB17-0 pins.

(3) Vcc = I/OVcc = 2.8 V, fFLM = 85 Hz

(4) Partial Pattern

40 Lines: White
280 Lines: Black
fFLM = 85 Hz
8-color mode



40 Lines: White

280 Lines: Black

(5) Vcc = I/OVcc = 2.8 V, Standby mode

(6) Refer to Item 4.1

6. OPTICAL CHARACTERISTICS

OPTICAL CHARACTERISTICS OF LCD (BACKLIGHT ON)

Item	Symbol	Condition	Min	Typ	Max	Unit	Note	
Brightness	B	$\phi=0^\circ, \theta=0^\circ$	170	250	-	cd/m ²	(1), (2)	
Contrast ratio	K	$\phi=0^\circ, \theta=0^\circ$	200	400	-	-	(1), (6)	
Viewing angle	$\phi_1 + \phi_2$	$\theta=0^\circ, K \geq 10$	-	160	-	deg	(4), (6), (7)	
		$\theta=90^\circ, K \geq 10$	-	160	-			
Brightness uniformity	-	$\phi=0^\circ, \theta=0^\circ$	70	80	-	%	(2), (3), (5)	
Response time	tr + tf	$\phi=0^\circ, \theta=0^\circ$ Ta=25°C	-	40	70	ms	(8)	
Color tone (Primary Color)	Red	x	Maximum Gradient $\phi=0^\circ$ $\theta=0^\circ$	0.57	0.63	0.69	-	(1)
		y		0.27	0.33	0.39		
	Green	x		0.28	0.34	0.40		
		y		0.53	0.59	0.65		
	Blue	x		0.08	0.14	0.20		
		y		0.05	0.11	0.17		
	White	x		0.25	0.31	0.37		
		y		0.26	0.32	0.38		

Common conditions for measurement

Measurement environment : Dark room
 Ambient temperature : Ta = 25°C
 Sequence : Follow Item 8.4.2, SEQUENCE.
 Power supply voltage : Vcc = VOVcc = 2.8 V
 Backlight current : 18 mA

Notes (1) Definition of Brightness "B"

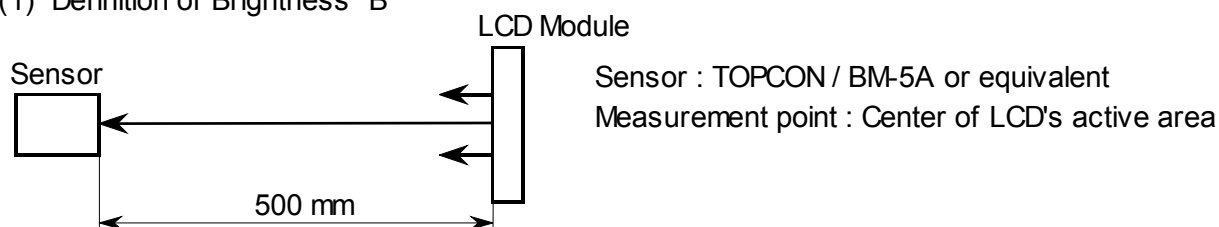

(2) Display image for measurement : White

Notes (3) Measurement point

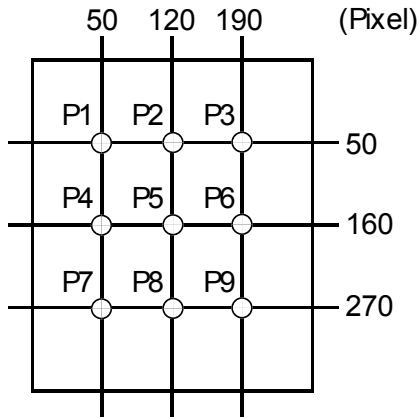

(4) Definitions of θ and ϕ

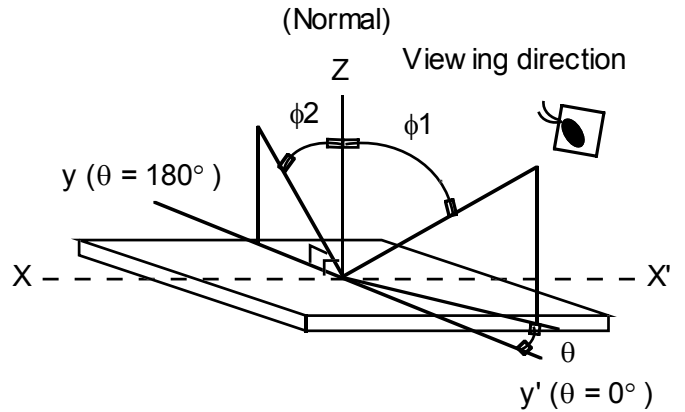

(5) Definition of the brightness uniformity

$$\text{Uniformity} = \frac{\text{Brightness (min.)}}{\text{Brightness (max.)}} \times 100(\%)$$

(6) Definition of Contrast "K"

$$K = \frac{\text{Brightness when displaying White raster}}{\text{Brightness when displaying Black raster}}$$

(7) Definition of viewing angle ϕ_1 and ϕ_2

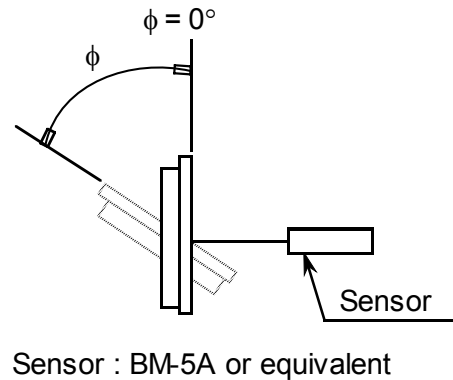
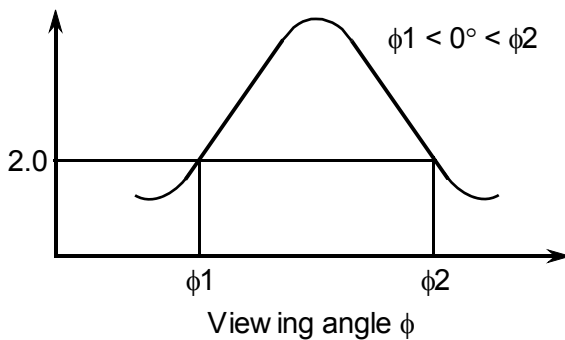

(8) Definition of optical response time

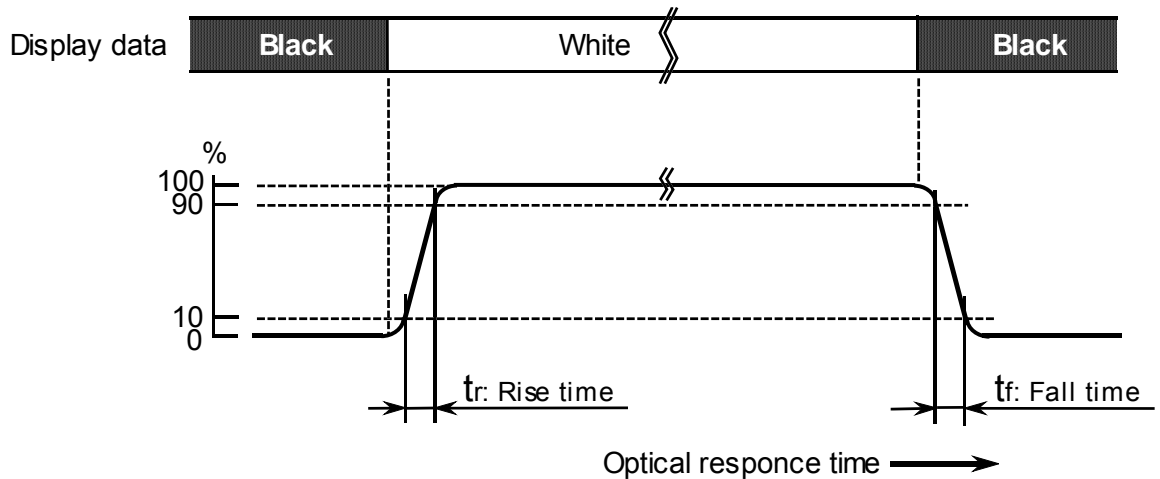

7. BLOCK DIAGRAM

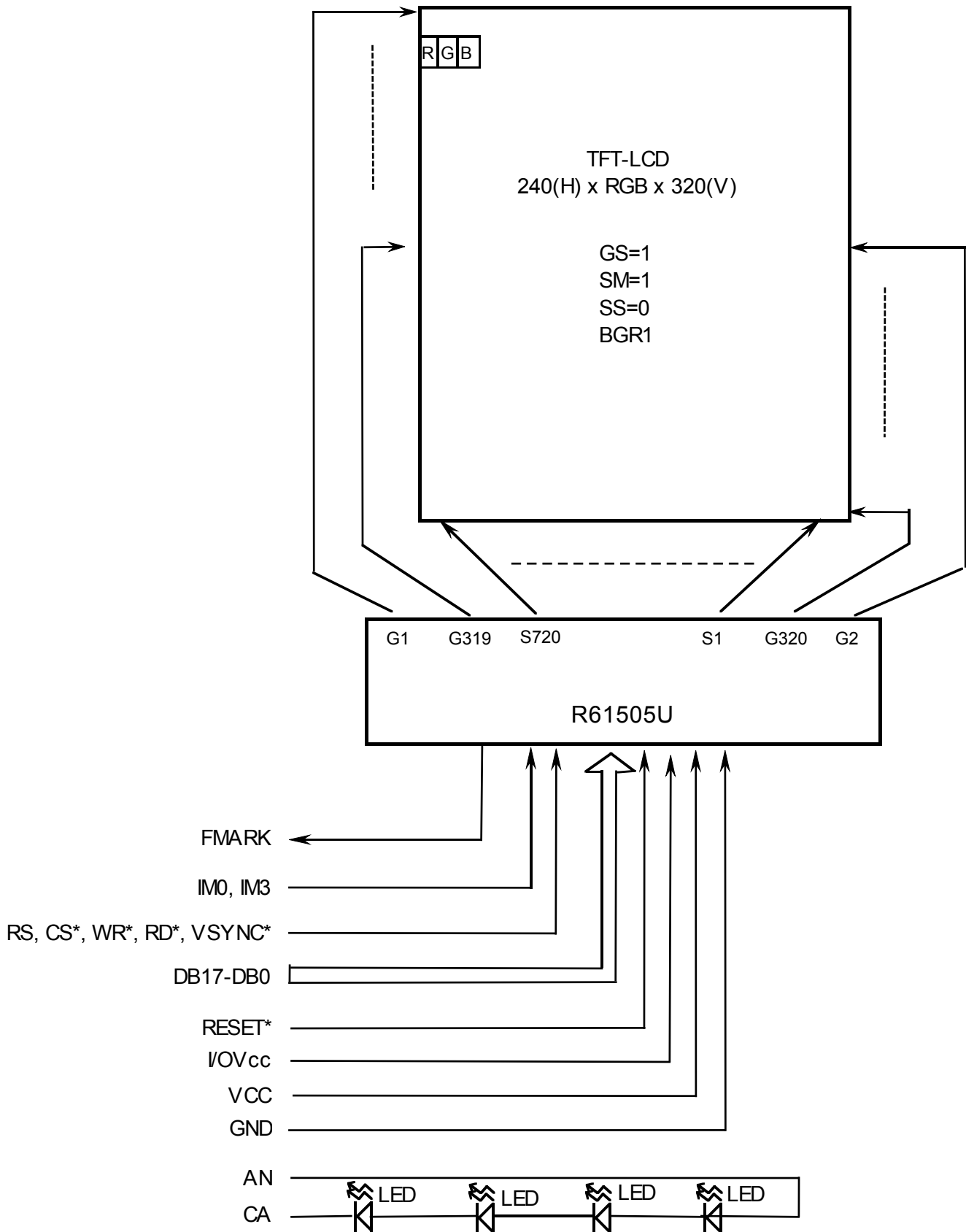

8. INTERFACE

8.1 INTERNAL PIN CONNECTION (8 / 9 / 16/18-bit CPU bus correspondence)

Pin No.	Signal	Function	Pin No.	Signal	Function
1	GND	GND	21	DB3	Data Bus (Instruction & Display Data)
2	GND	GND	22	DB2	Data Bus (Instruction & Display Data)
3	ID	ID(I/OVcc)	23	DB1	Data Bus (Instruction & Display Data)
4	IM0	MPU Interface Sw itching	24	DB0	Data Bus (Instruction & Display Data)
5	IM3	MPU Interface Sw itching	25	RD*	Read
6	RESET*	Reset	26	WR*	Write
7	DB17	Data Bus (Instruction & Display Data)	27	RS	Data/Command Identification
8	DB16	Data Bus (Instruction & Display Data)	28	CS*	Chip Select
9	DB15	Data Bus (Instruction & Display Data)	29	I/OVcc	Power Supply for Interface
10	DB14	Data Bus (Instruction & Display Data)	30	I/OVcc	Power Supply for Interface
11	DB13	Data Bus (Instruction & Display Data)	31	Vcc	Power Supply for Logic and Analog
12	DB12	Data Bus (Instruction & Display Data)	32	Vcc	Power Supply for Logic and Analog
13	DB11	Data Bus (Instruction & Display Data)	33	NC	NC (No Connection)
14	DB10	Data Bus (Instruction & Display Data)	34	AN	Power Supply for LED
15	DB9	Data Bus (Instruction & Display Data)	35	CA	GND for LED
16	DB8	Data Bus (Instruction & Display Data)	36	VSYNC*	Line synchronous signal
17	DB7	Data Bus (Instruction & Display Data)	37	FMARK	Frame head pulse signal
18	DB6	Data Bus (Instruction & Display Data)	38	NC	NC (No Connection)
19	DB5	Data Bus (Instruction & Display Data)	39	GND	GND
20	DB4	Data Bus (Instruction & Display Data)			

Suitable Connector : HIROSE FH26-39S-0.3SHW(5)

8.2 CPU INTERFACE MODE SETTING

8.2.1 CPU Interface Mode Selection

PIN No.	SIGNAL	80-System Bus Interface			
		18-bit	16-bit	9-bit	8-bit
		262k Colors	65k Colors	262k Colors	65k Colors
4	IM0	GND	GND	I/OVcc	I/OVcc
5	IM3	I/OVcc	GND	I/OVcc	GND

Select the interface mode and colors by setting bits of IM0 and IM3.

8.2.2 Unused Data Bus Connection

Bus Interface		18-bit	16-bit	9-bit	8-bit
Data Bus Pins		DB17-0	DB17-10 DB8-1	DB17-9	DB17-10
Unused Data Bus Pins		-	DB9,DB0	DB8-0	DB9-0
Pin No.	Signal				
7	DB17				
8	DB16				
9	DB15				
10	DB14				
11	DB13				
12	DB12				
13	DB11				
14	DB10				
15	DB9		GND or I/OVCC		GND or I/OVCC
16	DB8			GND or I/OVCC	GND or I/OVCC
17	DB7			GND or I/OVCC	GND or I/OVCC
18	DB6			GND or I/OVCC	GND or I/OVCC
19	DB5			GND or I/OVCC	GND or I/OVCC
20	DB4			GND or I/OVCC	GND or I/OVCC
21	DB3			GND or I/OVCC	GND or I/OVCC
22	DB2			GND or I/OVCC	GND or I/OVCC
23	DB1			GND or I/OVCC	GND or I/OVCC
24	DB0		GND or I/OVCC	GND or I/OVCC	GND or I/OVCC

Unused data bus pins are to be set at GND or I/OVCC.

8.2.3 Display Data Input

Data Bus		DB 17	DB 16	DB 15	DB 14	DB 13	DB 12	DB 11	DB 10	DB 9	DB 8	DB 7	DB 6	DB 5	DB 4	DB 3	DB 2	DB 1	DB 0
18-bit	Transfer 1	R5	R4	R3	R2	R1	R0	G5	G4	G3	G2	G1	G0	B5	B4	B3	B2	B1	B0
16-bit	Transfer 1	R5 R0	R4	R3	R2	R1	G5	G4	G3	-	G2	G1	G0	B5 B0	B4	B3	B2	B1	-
9-bit	Transfer 1	R5	R4	R3	R2	R1	R0	G5	G4	G3	-	-	-	-	-	-	-	-	-
	Transfer 2	G2	G1	G0	B5	B4	B3	B2	B1	B0	-	-	-	-	-	-	-	-	-
8-bit	Transfer 1	R5 R0	R4	R3	R2	R1	G5	G4	G3	-	-	-	-	-	-	-	-	-	-
	Transfer 2	G2	G1	G0	B5 B0	B4	B3	B2	B1	-	-	-	-	-	-	-	-	-	-

8.3 INTERFACE TIMING

8.3.1 80-System Bus Interface Timing Characteristics <<18 bits / 16 bits>>

[Normal Write Mode (HWM = 0), I/OV_{cc} = 1.75 to 2.8 V]

V_{cc} = 2.8 V

Item		Symbol	Unit	Min	Typ	Max
Bus cycle time	Write	tCYCW	ns	132	-	-
	Read	tCYCR	ns	473	-	-
Write low -level pulse width		PWLW	ns	48	-	-
Read low -level pulse width		PWLR	ns	179	-	-
Write high-level pulse width		PWHW	ns	74	-	-
Read high-level pulse width		PWHR	ns	263	-	-
Write/read rise/fall time		tWRr, tWRf	ns	-	-	23
Set up time	Write (RS to CS*, WR*)	tAS	ns	0	-	-
	Read (RS to CS*, RD*)	tAS	ns	11	-	-
Address hold time		tAH	ns	3	-	-
Write data set up time		tDSW	ns	27	-	-
Write data hold time		tH	ns	11	-	-
Read data delay time		tDDR	ns	-	-	142
Read data hold time		tDHR	ns	6	-	-

[High-Speed Write Mode (HWM = 1), I/OV_{cc} = 1.75 to 2.8 V]

V_{cc} = 2.8 V

Item		Symbol	Unit	Min	Typ	Max
Bus cycle time	Write	tCYCW	ns	79	-	-
	Read	tCYCR	ns	473	-	-
Write low -level pulse width		PWLW	ns	42	-	-
Read low -level pulse width		PWLR	ns	179	-	-
Write high-level pulse width		PWHW	ns	27	-	-
Read high-level pulse width		PWHR	ns	263	-	-
Write/read rise/fall time		tWRr, tWRf	ns	-	-	23
Set up time	Write (RS to CS*, WR*)	tAS	ns	0	-	-
	Read (RS to CS*, RD*)	tAS	ns	11	-	-
Address hold time		tAH	ns	3	-	-
Write data set up time		tDSW	ns	27	-	-
Write data hold time		tH	ns	11	-	-
Read data delay time		tDDR	ns	-	-	142
Read data hold time		tDHR	ns	6	-	-

8.3.2 80-System Bus Interface Timing Characteristics <<9 bits / 8 bits>>

[Normal Write Mode (HWM=0)/High-Speed Write Mode (HWM=1), $I/OV_{cc}=1.75$ to $2.8V$]

$V_{cc} = 2.8 V$

Item		Symbol	Unit	Min	Typ	Max
Bus cycle time	Write	tCYCW	ns	74	-	-
	Read	tCYCR	ns	473	-	-
Write low -level pulse width		PWLW	ns	32	-	-
Read low -level pulse width		PWLR	ns	179	-	-
Write high-level pulse width		PWHW	ns	27	-	-
Read high-level pulse width		PWHR	ns	263	-	-
Write/Read rise/fall time		tWRr, tWRf	ns	-	-	23
Set up time	Write (RS to CS*, WR*)	tAS	ns	0	-	-
	Read (RS to CS*, RD*)	tAS	ns	11	-	-
Address hold time		tAH	ns	3	-	-
Write data set up time		tDSW	ns	27	-	-
Write data hold time		tH	ns	11	-	-
Read data delay time		tDDR	ns	-	-	142
Read data hold time		tDHR	ns	6	-	-

8.3.3 Reset Timing Characteristics

[$I/OV_{cc}=1.75$ to $2.8V$]

$V_{cc} = 2.8 V$

Item	Symbol	Unit	Min	Typ	Max
Reset low -level width	tRES	ms	2	-	-
Reset rise time	trRES	us	-	-	9

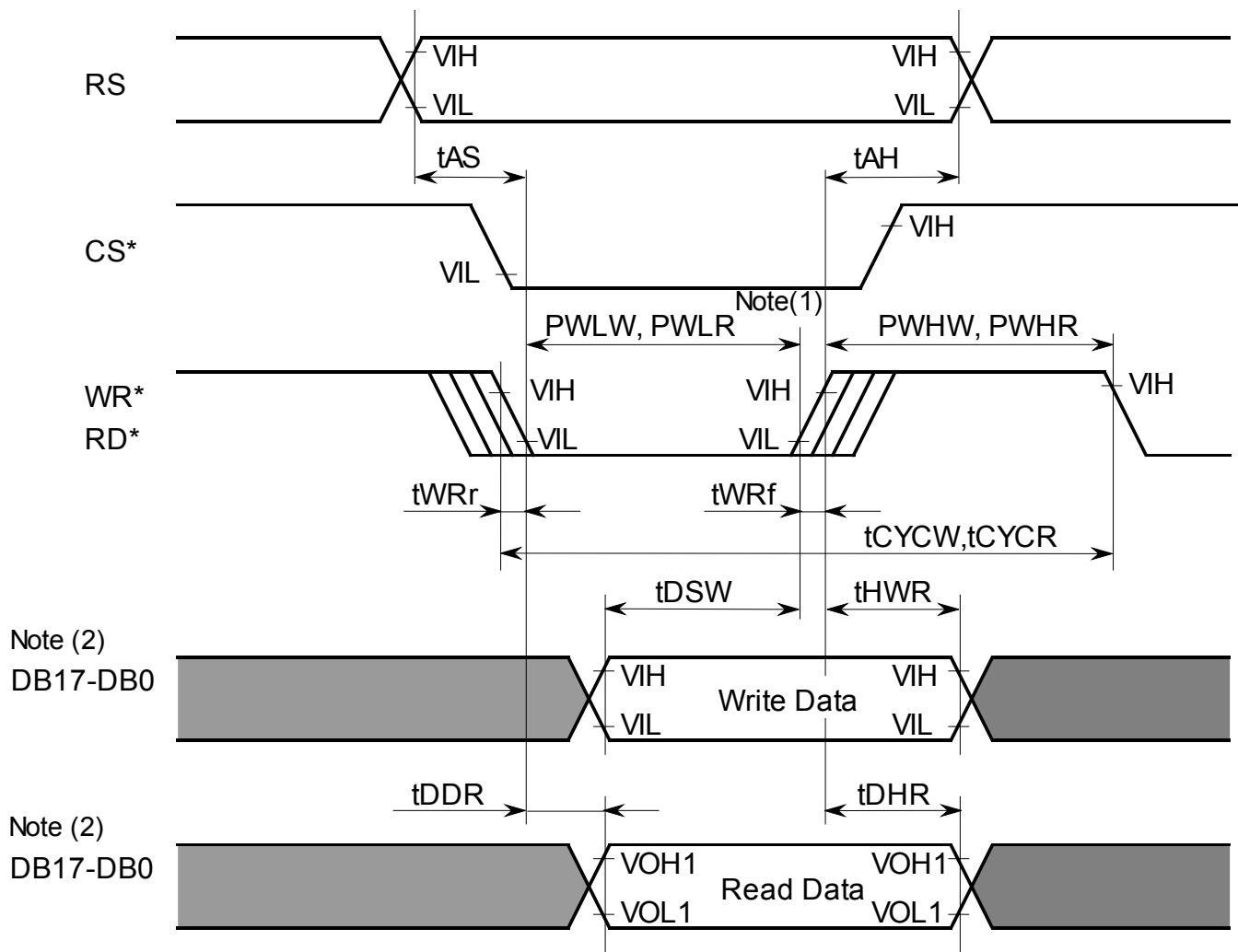

Bus Timing

Notes (1) PWLW and PWLR are defined by the overlap period when CS* is low and when WR* or RD* is low.

(2) Fix unused DB pins to either Vcc or GND level.

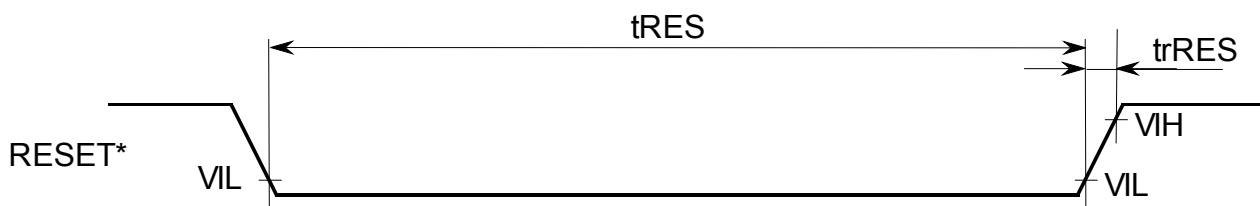

Reset Timing

8.4 REGISTER SETTING

8.4.1 State Transition Diagram of Operation Mode

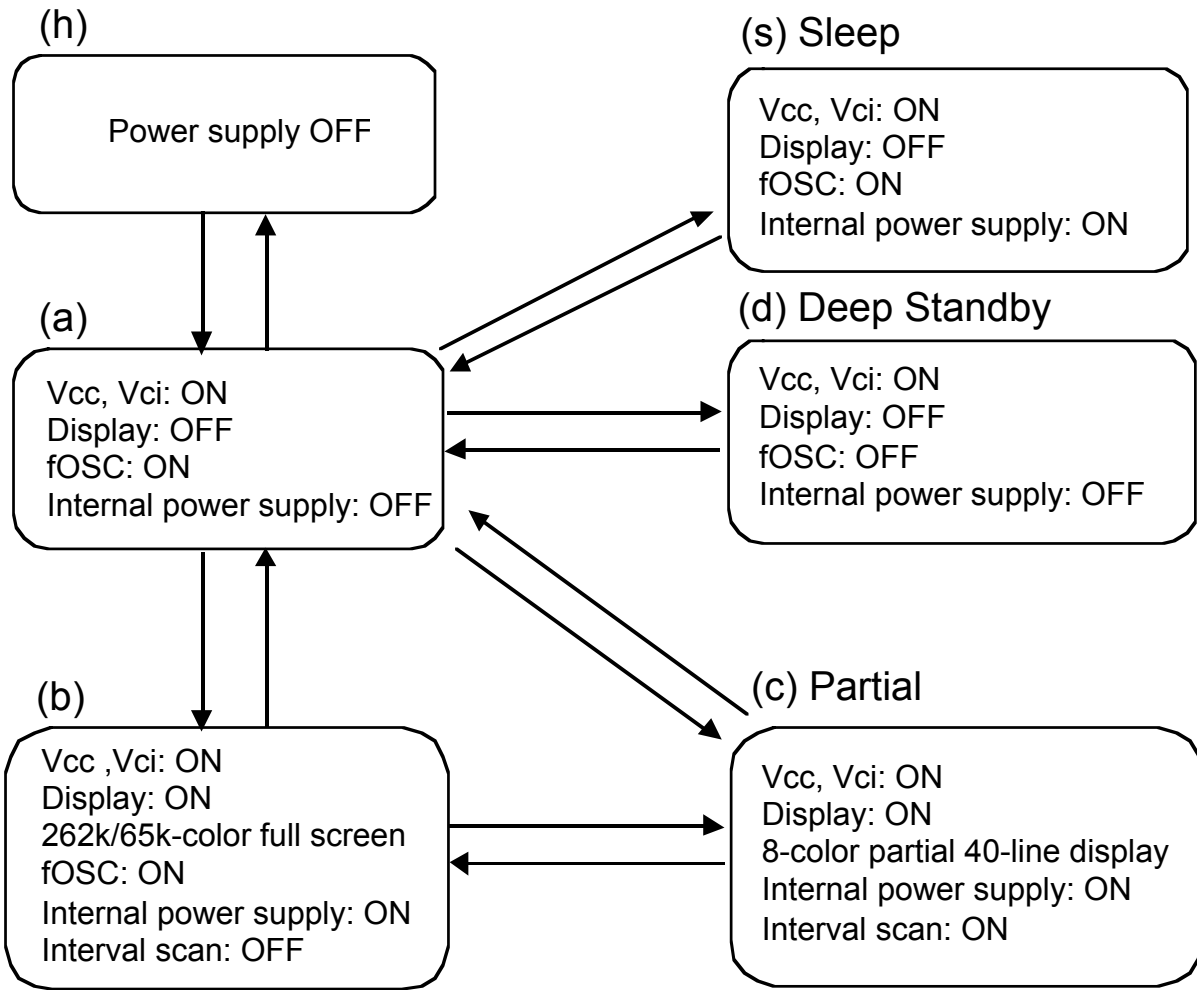

State (a) to (b)			State (a) to (b)		
		last proposal			last proposal
1		RA4h 0x0001		1	RA4h 0x0001
2		wait 1ms		2	wait 1ms
3	Power sequence control	R07h 0x0021		3	Power sequence control R07h 0x0021
4		wait 10 ms		4	wait 10 ms
5		R17h 0x0001		5	R17h 0x0001
6		wait 10 ms		6	wait 10 ms
7		R19h 0x0000		7	R19h 0x0000
8	Power start (1)	R10h 0x17B0		8	Power start (1) R10h 0x17B0
9		R11h 0x0016		9	R11h 0x0016
10		R12h 0x019E 0x009E		10	R12h 0x019E 0x009E
11		R13h 0x1600		11	R13h 0x1600
12		R14h 0x8000		12	R14h 0x8000
13		wait 10 ms		13	wait 10 ms
14	Power start (2)	R12h 0x01BE 0x00BE		14	Power start (2) R12h 0x01BE 0x00BE
15		wait 120 ms		15	wait 120 ms
16	Driver output control	R01h 0x0500		16	Driver output control R01h 0x0500
17	LCD driving wave control	R02h 0x0400		17	LCD driving wave control R02h 0x0400
18	Entry mode	R03h 0x1230		18	Entry mode R03h 0x1230
19	Display control (2)	R08h 0x0808		19	Display control (2) R08h 0x0808
20	ISC control	R09h 0x0000		20	ISC control R09h 0x0401
21	Display control (4)	R0Ah 0x0008		21	Display control (4) R0Ah 0x0008
22		R0Ch 0x0000		22	R0Ch 0x0000
23		R0Dh 0x0000		23	R0Dh 0x0000
24	Gamma setting	R30h 0x0704 0x0703		24	Gamma setting R30h 0x0704 0x0703
25		R31h 0x0003 0x0001		25	R31h 0x0003 0x0001
26		R32h 0x0000 0x0004		26	R32h 0x0000 0x0004
27		R33h 0x0103 0x0102		27	R33h 0x0103 0x0102
28		R34h 0x0000 0x0300		28	R34h 0x0000 0x0300
29		R35h 0x0006 0x0103		29	R35h 0x0006 0x0103
30		R36h 0x001F 0x001F		30	R36h 0x001F 0x001F
31		R37h 0x0704 0x0703		31	R37h 0x0704 0x0703
32		R38h 0x0003 0x0001		32	R38h 0x0003 0x0001
33		R39h 0x0000 0x0004		33	R39h 0x0000 0x0004
34		R3Ah 0x0103 0x0102		34	R3Ah 0x0103 0x0102
35		R3Bh 0x0000 0x0300		35	R3Bh 0x0000 0x0300
36		R3Ch 0x0006 0x0103		36	R3Ch 0x0006 0x0103
37		R3Dh 0x001F 0x001F		37	R3Dh 0x001F 0x001F
38	Horizontal RAM start address	R50h 0x0000		38	Horizontal RAM start address R50h 0x0000
39	Horizontal RAM end address	R51h 0x00EF		39	Horizontal RAM end address R51h 0x00EF
40	Vertical RAM start address	R52h 0x0000		40	Vertical RAM start address R52h 0x0000
41	Vertical RAM end address	R53h 0x013F		41	Vertical RAM end address R53h 0x0027
42		R60h 0x2700		42	R60h 0x2700
43		R61h 0x0000		43	R61h 0x0000
44		R6Ah 0x0000		44	R6Ah 0x0000
45		R80h 0x0000		45	R80h 0x0000
46		R81h 0x0000		46	R81h 0x0000
47		R82h 0x0027		47	R82h 0x0027
48	Frame frequency control	R90h 0x0015		48	Frame frequency control R90h 0x0015
49		R92h 0x0000		49	R92h 0x0000
50		R93h 0x0002		50	R93h 0x0002
51		R20h 0x0000		51	R20h 0x0000
52		R21h 0x0000		52	R21h 0x0000
53	Write data to GRAM	R22h -		53	Write data to GRAM R22h -
54		Display data write 240x320 size		54	Display data write 240x40 size
55	Display ON	R07h 0x0021		55	Display ON R07h 0x0021
56		wait 8 line min		56	wait 8 line min
57		R10h 0x17B0		57	R10h 0x17B0
58		R11h 0x0017		58	R11h 0x0017
59		R07h 0x0061		59	R07h 0x0061
60		wait 2 frame min		60	wait 2 frame min
61		R07h 0x0173		61	R07h 0x017B
62	Image refresh	R20h 0x0000		62	Image refresh R20h 0x0000
63		R21h 0x0000		63	R21h 0x0000
64		R22h -		64	R22h -
65		Display data write 240x320 size		65	Display data write 240x40 size

State (a) to (d)

1 Deep Standby R10h 0x0004 last proposal

State (d) to (a)

last proposal

Cancel deep standby mode by inputting CS="Low" and WR="Low" (9-/ 8-bit interface)

- | | | | |
|---|----------------------------|-------------------------|----|
| 1 | DSTB mode cancellation (1) | Index write(DATA=8'h00) | *1 |
| 2 | DSTB mode cancellation (2) | Index write(DATA=8'h00) | |
| 3 | | wait 1ms min | |
| 4 | DSTB mode cancellation (3) | Index write(DATA=8'h00) | |
| 5 | DSTB mode cancellation (4) | Index write(DATA=8'h00) | |
| 6 | DSTB mode cancellation (5) | Index write(DATA=8'h00) | |
| 7 | DSTB mode cancellation (6) | Index write(DATA=8'hF0) | |
| 8 | | wait 50 ms | |

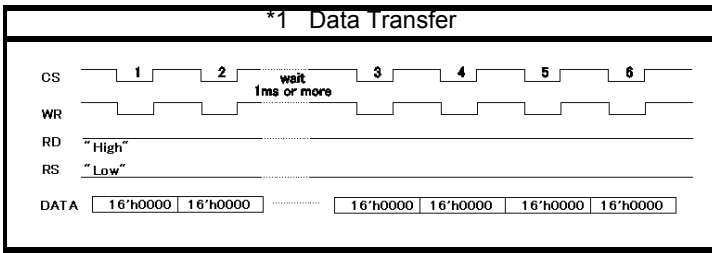

Cancel deep standby mode by inputting CS="Low" (18-/ 16-/ 9-/ 8-bit interface)

- | | | | |
|---|----------------------------|-------------------------|----|
| 1 | DSTB mode cancellation (1) | CS="Low" | *2 |
| 2 | DSTB mode cancellation (2) | Index write(DATA=8'h00) | |
| 3 | | wait 1ms | |
| 4 | DSTB mode cancellation (3) | CS="Low" | |
| 5 | DSTB mode cancellation (4) | CS="Low" | |
| 6 | DSTB mode cancellation (5) | CS="Low" | |
| 7 | DSTB mode cancellation (6) | CS="Low" | |
| 8 | | wait 10 ms | |

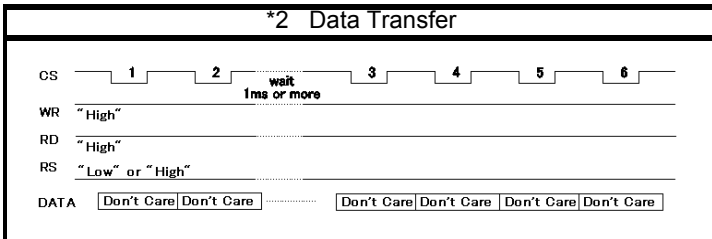

9. DIMENSIONAL OUTLINE

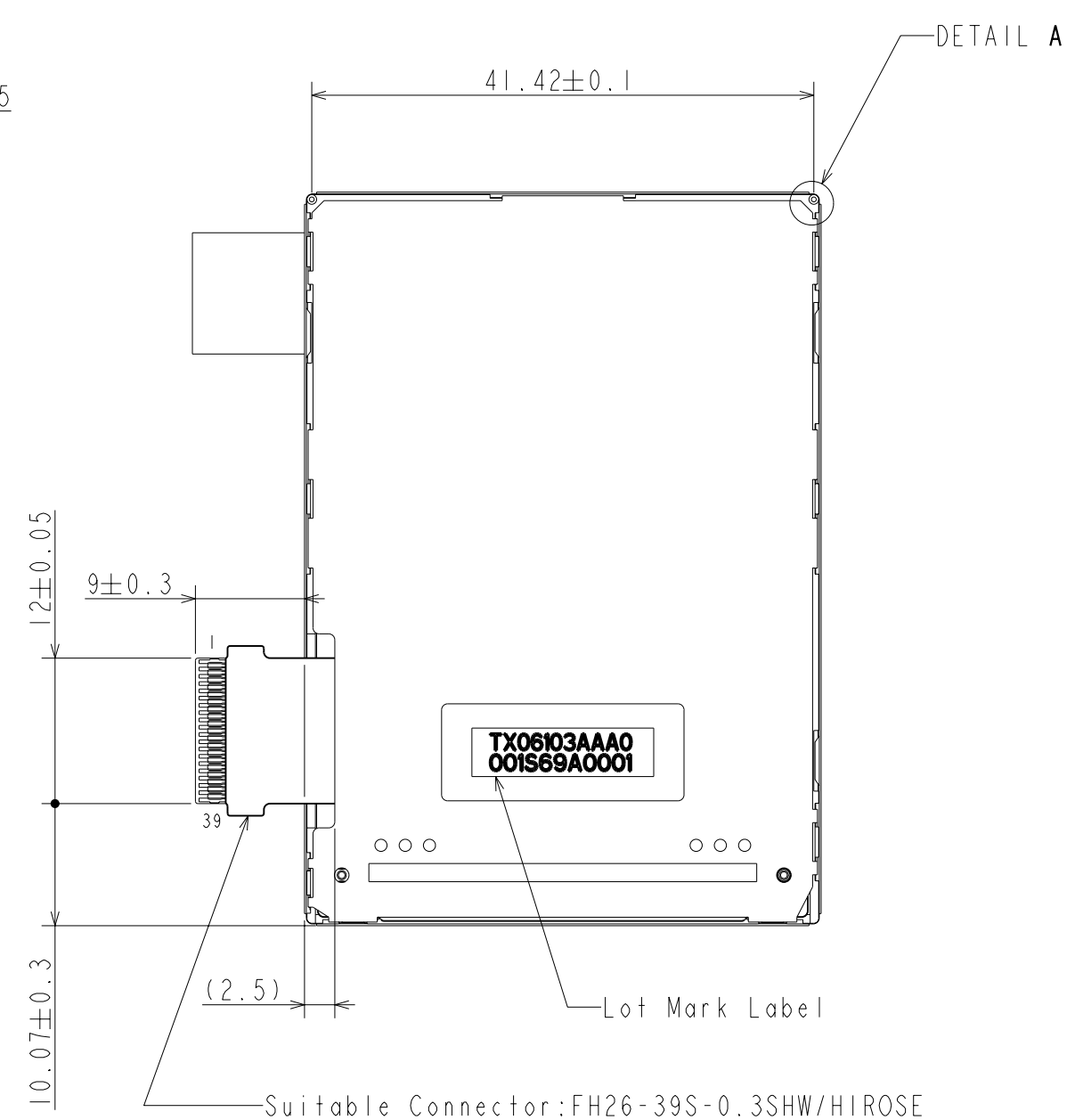
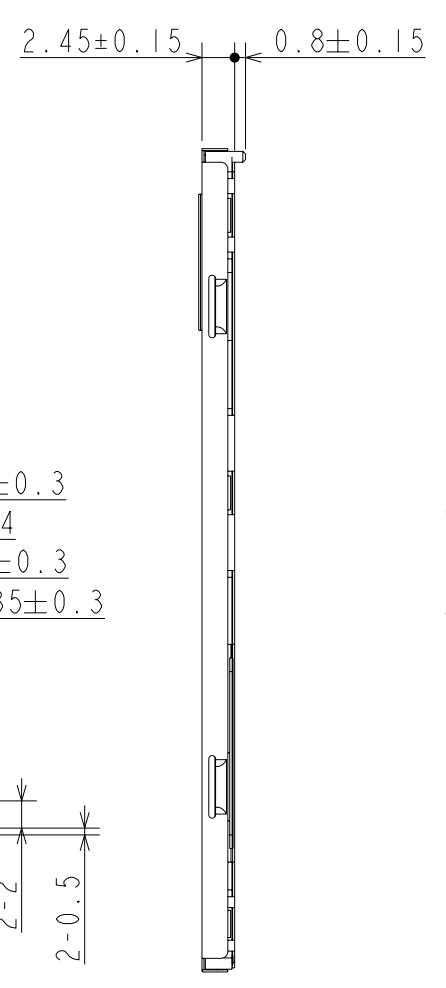
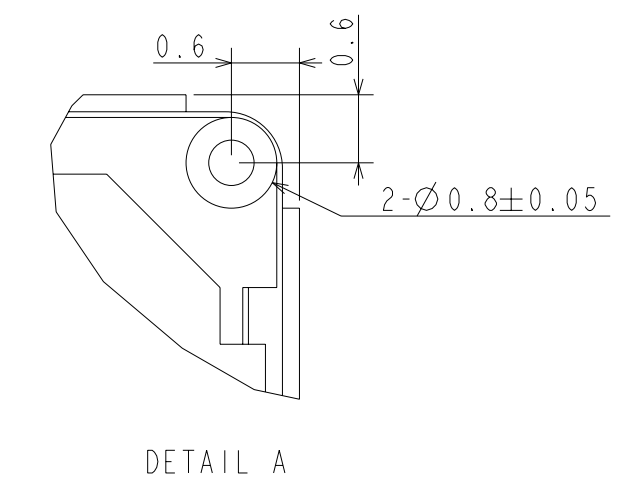
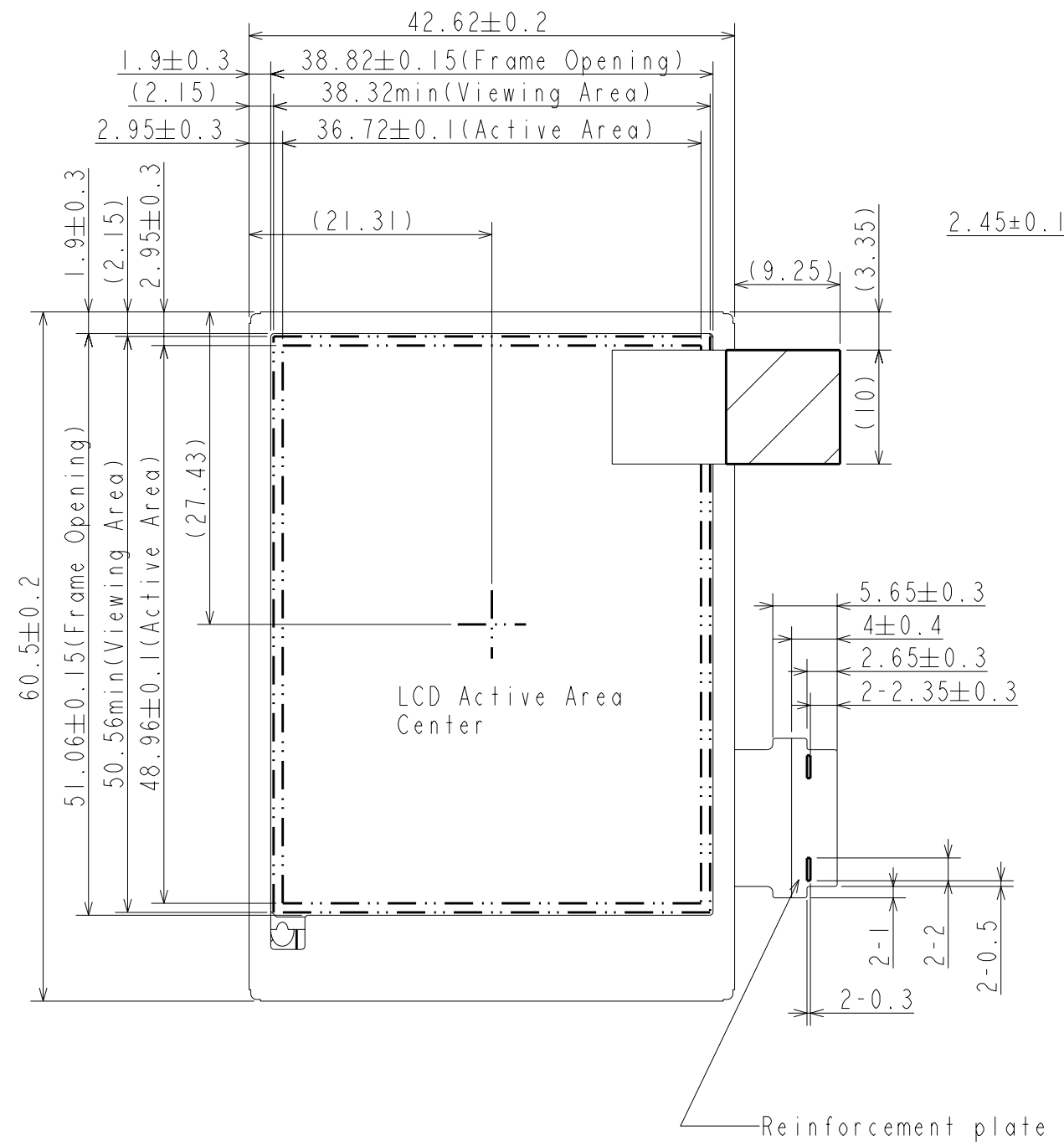

Unit:mm
 Note
 (1) The unspecified to tolerance: ± 0.2