

HITACHI

Hitachi Displays, Ltd.

Date : June 8, 2006

For Messrs. Hitachi Europe Ltd.

CUSTOMER'S ACCEPTANCE SPECIFICATIONS

TX06D57VM0AAA

CONTENTS

No.	Item	Sheet No.	Page
1	COVER	3284PS2601-TX06D57VM0AAA-1A	1-1/1
2	RECORD OF REVISIONS	3284PS2602-TX06D57VM0AAA-1A	2-1/1
3	GENERAL DATA	3284PS2603-TX06D57VM0AAA-1A	3-1/1
4	ABSOLUTE MAXIMUM RATINGS	3284PS2604-TX06D57VM0AAA-1A	4-1/1
5	ELECTRICAL CHARACTERISTICS	3284PS2605-TX06D57VM0AAA-1A	5-1/1
6	OPTICAL CHARACTERISTICS	3284PS2606-TX06D57VM0AAA-1A	6-1/2-2/2
7	BLOCK DIAGRAM	3284PS2607-TX06D57VM0AAA-1A	7-1/1
8	INTERFACE	3284PS2608-TX06D57VM0AAA-1A	8-1/11-11/11
9	DIMENSIONAL OUTLINE	3284PS2609-TX06D57VM0AAA-1A	9-1/1
10	VISUAL INSPECTION	3284PS2610-TX06D57VM0AAA-1A	10-1/3-3/3
11	PRECAUTIONS IN DESIGN	3284PS2611-TX06D57VM0AAA-1A	11-1/3-3/3
12	DESIGNATION OF LOT MARK	3284PS2612-TX06D57VM0AAA-1A	12-1/1
13	PACKING SPECIFICATIONS	3284PS2613-TX06D57VM0AAA-1A	13-1/7-7/7
14	PRECAUTIONS FOR USE	3284PS2614-TX06D57VM0AAA-1A	14-1/1

Please return 1 copy with your signature on this page for approval.

Accepted by : _____ Proposed by : _____

Date : _____

Hitachi Displays, Ltd.	Sh. No.	3284PS 2601 - TX06D57VM0AAA - 1A	Page	1-1/1
------------------------	------------	----------------------------------	------	-------

RECORD OF REVISIONS

Date	Sheet No.	Summary

3. GENERAL DATA

(1) Product Name	TX06D57VM0AAA
(2) Module Dimensions	39.8(W) mm x 56.1(H) mm x 2.7(t) mm Width: Excluding hooks of metal frame Thickness: Excluding electronic components
(3) Active Area Dimensions	33.84 (W) mm x 45.12 (H) mm
(4) Pixel Pitch	0.141 (W) mm x 0.141 (H) mm
(5) Resolution	240 x 3 (R,G,B) (W) x 320 (H) dots
(6) Color Pixel Arrangement	BGR Vertical Stripe
(7) Display Mode	Transmissive Type, Normally Black Mode
(8) Number of Colors	65,536 Colors (SPI, 16-bit RGB - I/F) 262,144 Colors (18-bit RGB - I/F)
(9) Viewing Direction	-
(10) Backlight	Light Emitting Diode (LED), Four LEDs connected in series
(11) Weight	12.6 g
(12) Power Supply Voltage	$V_{Ci} = 2.8 \text{ V}$ (typ) (for logic and analog circuits)
(13) Interface I/O power supply (Note (1))	$V_{CCIO} = 1.8 \text{ V}$ to V_{Ci} ($1.8 \text{ V} \leq V_{CCIO} \leq 2.8 \text{ V}$) The same voltage as "H" level of a customer's interface signal must be supplied to V_{CCIO} .
(14) LCD Driver IC	Source IC : BD663471 (with partial RAM (240xRGBx96 dots)) Gate and Power IC : HD66786U
(15) Interface	System interface : Clock synchronized Serial Interface (SPI) External display interface : 16-bit, 18-bit RGB Interface

Note (1) V_{CCIO} is the reference voltage for adjusting the I/O signal level of BD663471.
 V_{CCIO} voltage should be determined according to the customer's system.

4. ABSOLUTE MAXIMUM RATINGS

4. 1 ELECTRICAL ABSOLUTE MAXIMUM RATINGS OF LCD

VSS = 0 V, Ta = 25°C

Item	Symbol	Min	Max	Unit	Note
Power Supply for Interface	VCCIO	-0.3	4.0	V	(1), (2)
Power Supply for Logic and Analog	Vci	-0.3	4.0	V	(1), (2)
Input Voltage	Vi	-0.3	VCCIO+0.3	V	(1), (3)
Output Voltage	Vo	-0.3	VCCIO+0.3	V	(1), (4)
LED Reverse Voltage	VR	-	5	V	(1), (5)
LED Forward Current	ILED	-	35	mA	(5), (6)
Static Electricity	-	-	±2	kV	(7)

Notes

(1) All voltage values are referred to GND.

(2) $V_{CCIO} \leq V_{ci}$

VCCIO is the reference voltage for adjusting the I/O signal level of BD663471.

The same voltage as "H" level of a customer's interface signal must be supplied to VCCIO.

(3) Applies to the RESET, ID, SDI, SCL, CS*, VSYNC, HSYNC, DOTCLK and PD17 to PD0 pins.

(4) Applies to the SDO.

(5) Ta = 25°C, per piece of LED.

(6) Refer to Fig.1.

(7) 100 pF-1.5k ohm, 25°C-70%RH

Static electricity discharge point is the center of LCD's surface.

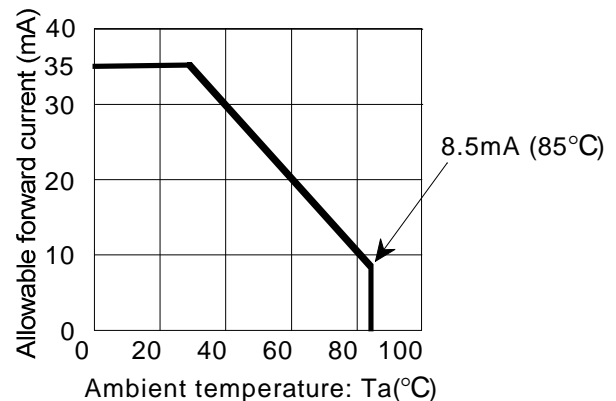

Fig.1 Ambient Temperature vs. Allowable Forward Current

4. 2 ENVIRONMENTAL ABSOLUTE MAXIMUM RATINGS

Item	Operating		Storage		Remarks
	Min	Max	Min	Max	
Ambient Temperature	-20°C	70°C	-30°C	80°C	Note (2)
Humidity	Note (1)		Note (1)		No condensation
Corrosive Gas	Not Acceptable		Not Acceptable		

Notes

(1) Ta ≤ 40°C: 95%RH max.

Ta > 40°C: Absolute humidity must be lower than the humidity of 95%RH at 40°C.

(2) Background color slightly changes depending on ambient temperature and viewing angle.

The speed of response is slower at 0 °C.

The temperature for operating in the table above apply to operation only.

Visual qualities, such as contrast and speed of response, to be evaluated at Ta = 25°C.

5. ELECTRICAL CHARACTERISTICS

5.1 TFT-LCD MODULE

VSS = 0 V, Ta = 25 °C

Item	Symbol	Condition	Min	Typ	Max	Unit	Note
Power Supply Voltage for Logic and Analog	V _{ci}	-	2.72	2.8	2.88	V	
Input Voltage for Logic Circuits	V _i	"H" level	0.85 V _{CCIO}	-	V _{CCIO}	V	(1), (2)
		"L" level	-0.3	-	0.15xV _{CCIO}		
Output Voltage for Logic Circuits	V _o	"H" level	0.75 V _{CCIO}	-	-	V	(1), (2)
		"L" level	-	-	0.2xV _{CCIO}		
Input/Output Leak current	I _{Li}	-	-1.0	-	1.0	μA	
Power Supply Current	I _{CC} + I _{ci}	All white	-	7.0	11.0	mA	(3)
		Partial	-	0.6	1.1	mA	(4)
		Standby	-	0.1	10	μA	(5)
Frame Frequency	Internal clock mode	f _{FLM}	Normal display operation	-	(75)	-	Hz
	RGB I/F mode	f _{FLM}	Normal display operation	(75)	85	(95)	Hz
LED Forward Voltage	V _{LED}	-	-	(3.2)	(3.5)	V	(6)
LED Forward Current	I _{LED}	-	-	15.0	(35)	mA	(6), (7)

Notes (1) 1.8 V ≤ V_{CCIO} ≤ V_{ci} (V_{CCIO} = 1.8 V to 2.8 V)

(2) Input: RESET*, ID, SDI, SCL, CS*, VSYNC, HSYNC, DOTCLK, ENABLE, PD17 to PD0

Output : SDO

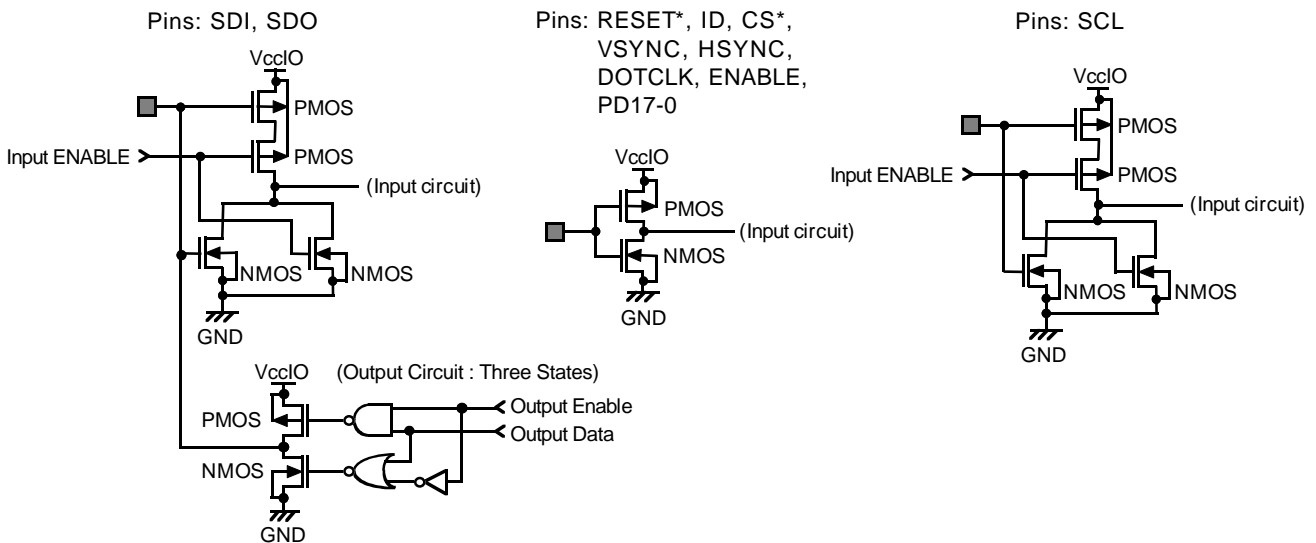

- (3) V_{ci} = V_{CCIO} = 2.8 V, RGB I/F mode, f_{FLM} = 85 Hz
Raster-row reversed AC drive
- (4) V_{ci} = V_{CCIO} = 2.8 V, 8-color mode, f_{FLM} = 50 Hz
Frame reversed AC drive, No RGB I/F input signals
Refer to Fig. 1, Partial Pattern.

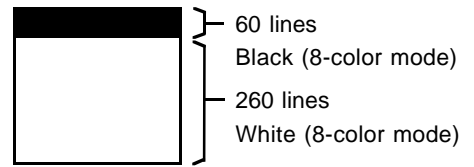

Fig.1 Partial Pattern

- (5) V_{ci} = V_{CCIO} = 2.8 V, Deep standby mode,
V_{ci}, V_{CCIO}: ON, Display: OFF
Internal oscillator: STOP, Power supply: OFF, No RGB I/F input signals.
- (6) It is the value for one LED.
- (7) The operating current of LED should be determined under the maximum rating of the temperature environmental condition.

6. OPTICAL CHARACTERISTICS

6.1 OPTICAL CHARACTERISTICS OF LCD (BACKLIGHT ON)

Item	Symbol	Condition	Min	Typ	Max	Unit	Note
Brightness	B	$\phi=0^\circ, \theta=0^\circ$	150	220	-	cd/m ²	(1)
Brightness Uniformity	-	$\phi=0^\circ, \theta=0^\circ$	70	80	-	%	(2), (4)
Viewing Angle	$\phi_2+\phi_1$	$\theta=0^\circ, K\geq 10$	-	160	-	deg	(3), (5), (6)
		$\theta=90^\circ, K\geq 10$	-	160	-		
Contrast Ratio	K	$\phi=0^\circ, \theta=0^\circ$	200	250	-	-	(5)
Response Time	tr+tf	$\phi=0^\circ, \theta=0^\circ$	-	60	120	ms	(7)
Color Tone (Primary Color)	Red	x	$\phi=0^\circ, \theta=0^\circ$	0.58	0.63	0.68	-
		y		0.31	0.36	0.41	
	Green	x		0.28	0.33	0.38	
		y		0.55	0.60	0.65	
	Blue	x		0.09	0.14	0.19	
		y		0.05	0.10	0.15	
	White	x		0.25	0.31	0.37	
		y		0.26	0.32	0.38	

Measurement Conditions

Measurement environment : Dark room

Ambient temperature : Ta = 25°C

Sequence : Refer to Item 8.5.2, SEQUENCE.

Power supply voltage : Vci = VCCIO = 2.8 V

Backlight current : ILED = 15 mA

Note (1) Definition of Brightness "B"



Sensor : TOPCON's BM-5A or equivalent

Measuring point : Center of LCD's active area

Notes (2) Measurement points

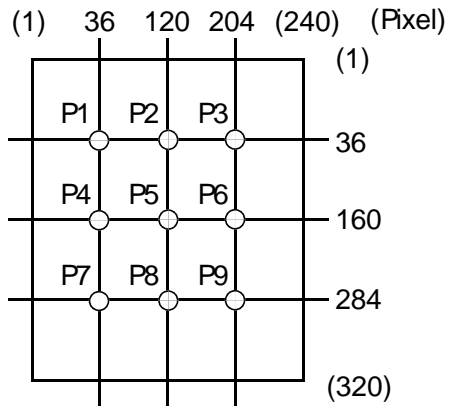

(3) Definition of θ and ϕ

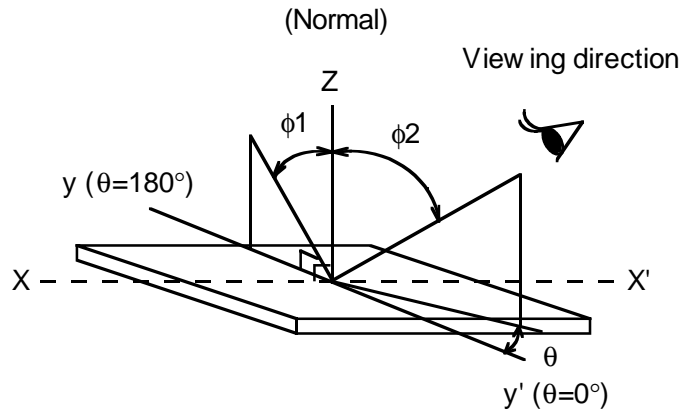

(4) Definition of Brightness Uniformity

$$\text{Brightness Uniformity} = \text{Brightness (min)} / \text{Brightness (max)} \times 100 (\%)$$

(5) Definition of Contrast "K"

$$K = \frac{\text{Brightness when displaying White raster}}{\text{Brightness when displaying Black raster}}$$

(6) Definition of Viewing Angle ϕ_1 and ϕ_2

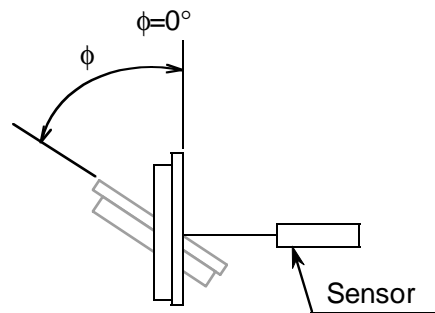
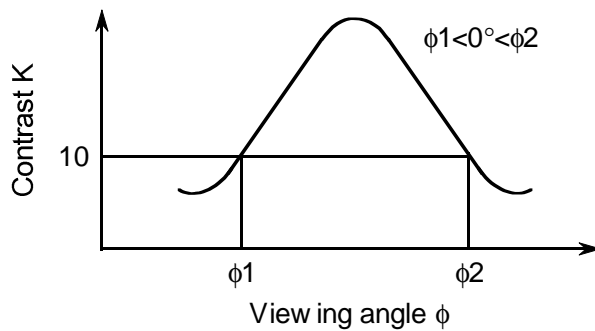

Sensor : TOPCON's BM-5A or equivalent

(7) Definition of Optical Response Time

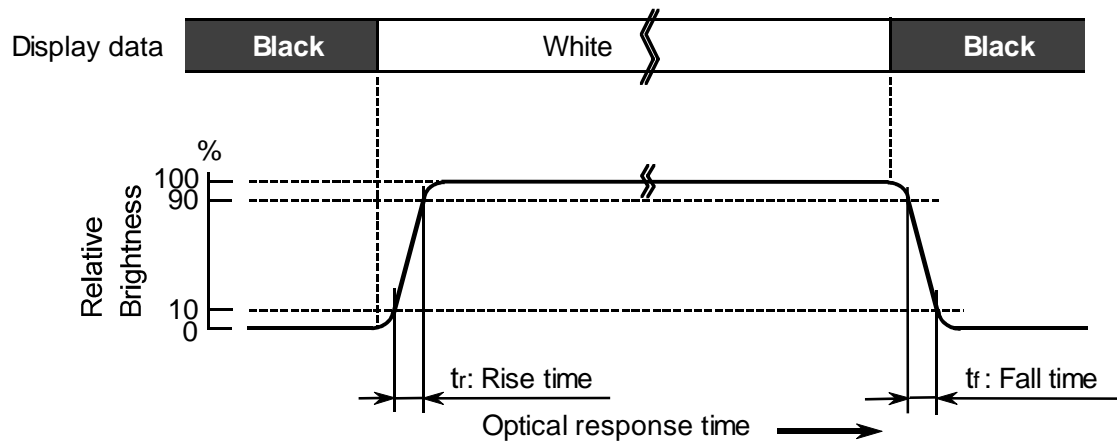

7. BLOCK DIAGRAM

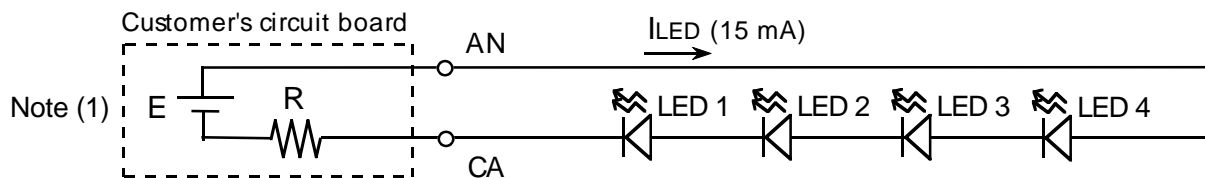
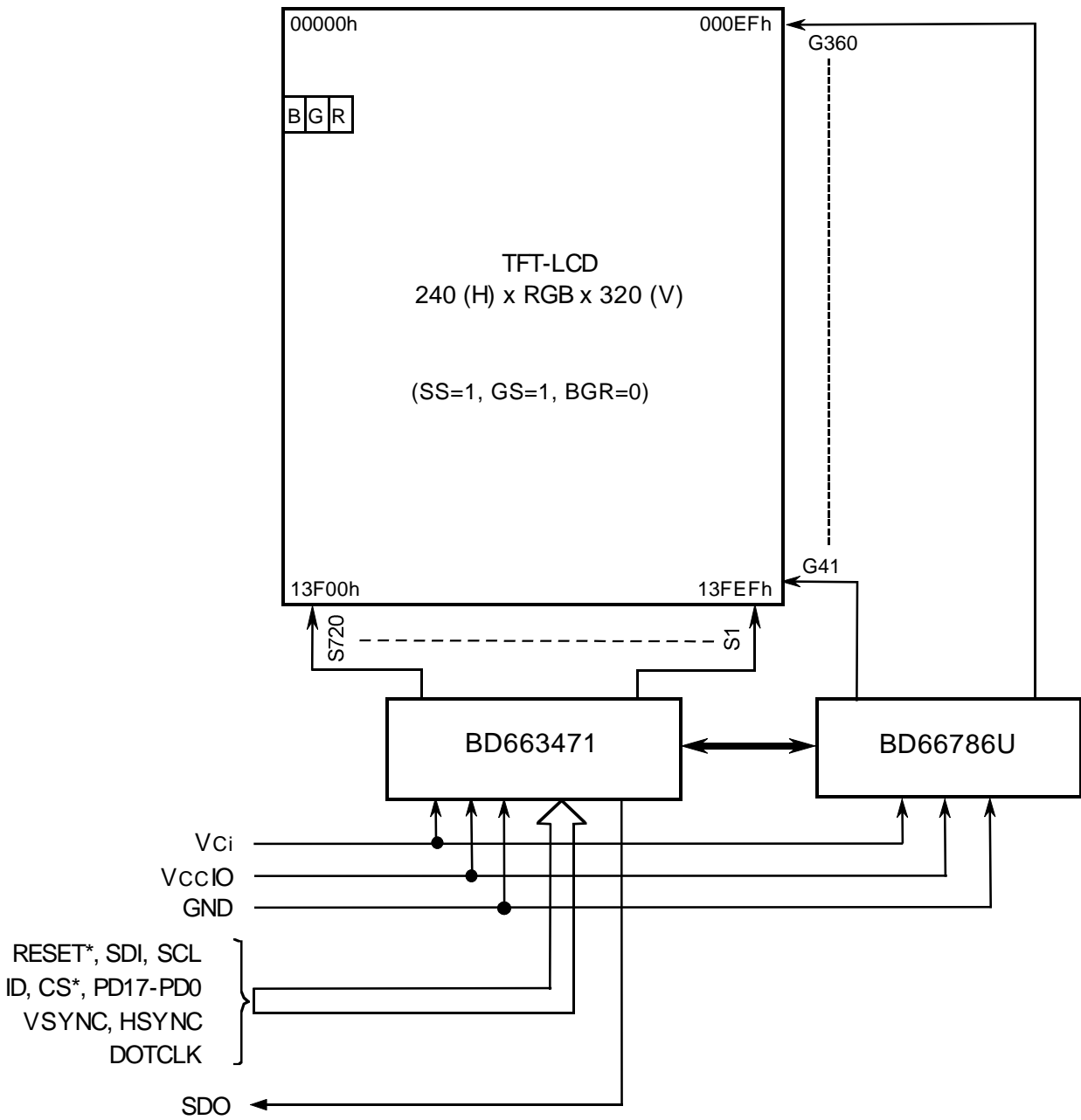

Note (1) R : Resistance for limiting current ($R \geq 100 \text{ ohm}$)

8. INTERFACE

8.1 INTERNAL PIN CONNECTION

Suitable Connector: HIROSE FH26-39S-0.3SHW(05)

Pin No.	Signal	Function
1	GND	Ground
2	GND	Ground
3	ID	ID bit setting of device ID code
4	Vci	Power supply for logic and analog circuit
5	Vci	Power supply for logic and analog circuit
6	VccIO	Power Supply for Interface signal
7	PD0	RGB data signal
8	PD1	RGB data signal
9	PD2	RGB data signal
10	PD3	RGB data signal
11	PD4	RGB data signal
12	PD5	RGB data signal
13	PD6	RGB data signal
14	PD7	RGB data signal
15	PD8	RGB data signal
16	PD9	RGB data signal
17	PD10	RGB data signal
18	PD11	RGB data signal
19	PD12	RGB data signal
20	PD13	RGB data signal
21	PD14	RGB data signal
22	PD15	RGB data signal
23	PD16	RGB data signal
24	PD17	RGB data signal
25	DOTCLK	Dot clock signal
26	HSYNC	Line synchronizing signal
27	VSYNC	Frame synchronizing signal
28	SC*	Chip select signal
29	SCL	Serial clock signal
30	SDI	Serial Instruction data input
31	SDO	Serial Instruction data output
32	REEST*	Reset signal
33	GND	Ground
34	LED(AN)	VLED(+) (Anode)
35	LED(AN)	VLED(+) (Anode)
36	LED(CA)	VLED(-) (Cathode)
37	LED(CA)	VLED(-) (Cathode)
38	GND	Ground
39	GND	Ground

Note (1) In serial interface mode, leave the SDO pin open when it is not used.

8.2 INTERFACE MODE SETTING

8.2.1 SPI INTERFACE MODE

ID pin connection	ID bit
GND	0
VccIO	1

RS	R/W	Function
0	0	Set an index register
1	0	Write an instruction or RAM data
1	1	Read an instruction or RAM data

ID bit of the device ID code is determined by ID pin connection.

ID pin must be connected to GND or VccIO according to the customer's system.

Basic data transferred through SPI

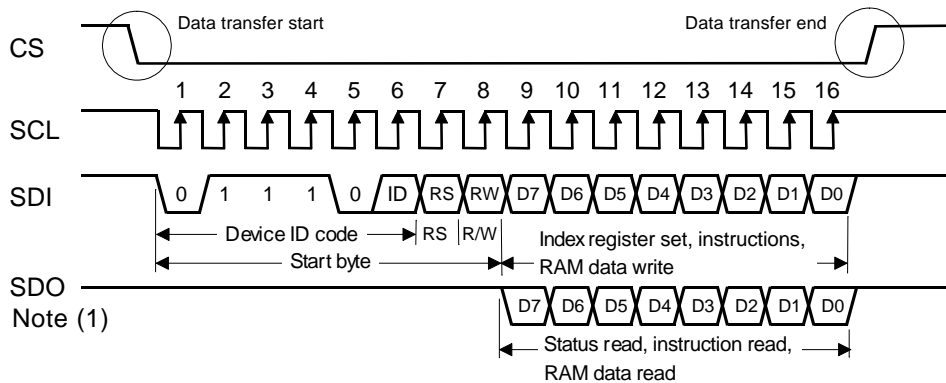

Note (1) When reading data from SDO, the start byte of a read command must be transferred.

8.2.2 RGB INTERFACE MODE

RGB INTERFACE MODE & UNUSED PIN CONNECTION

RGB Interface Mode		18-bit	16-bit
Number of display colors		262k	65k
RGB Data Bus Pins		PD17-0	PD17-13, PD11-1
Unused RGB Data Bus Pins		None	PD12, PD0
Pin No.	Signal		
19	PD12	-	GND
7	PD0	-	GND

In 16-bit RGB-I/F, PD12 and PD0 pins must be fixed to GND level.

INPUT DATA & RGB DATA

18-bit RGB INTERFACE

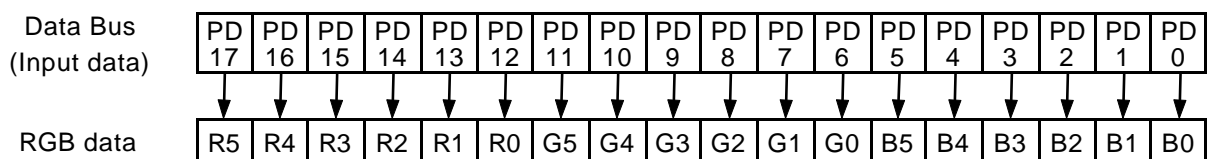

16-bit RGB INTERFACE

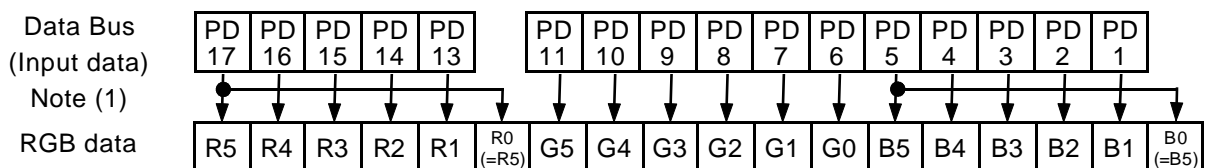

Note (1) The data of PD17 is R5, and the data of PD5 is B5.

In 16-bit RGB-I/F, the input data are expanded into 18-bit by adding one bit (the same data as the MSB of RB) to the LSB of RB data within BD663471.

8.3 PARTIAL RAM ADDRESS MAP

Partial RAM: 240xRGBx96 dots

	(OSD0)				(OSD1)				(OSD2)				(OSD3)				(OSD236)				(OSD237)				(OSD238)				(OSD239)			
	S1	S2	S3		S4	S5	S6		S7	S8	S9		S10	S11	S12		S709	S710	S711		S712	S713	S714		S715	S716	S717		S718	S719	S720	
	PD				PD				PD				PD				PD				PD				PD							
	3	0	1	2	3	0	1	2	3	0	1	2	3	0	1	2	3	0	1	2	3	0	1	2	3	0	1	2	3	0	1	2
Gn=1	"0000"H	"0001"H	"0002"H	"0003"H	"00EC"H	"00ED"H	"00EE"H	"00EF"H																							
Gn=2	"0100"H	"0101"H	"0102"H	"0103"H	"01EC"H	"01ED"H	"01EE"H	"01EF"H																							
Gn=3	"0200"H	"0201"H	"0202"H	"0203"H	"02EC"H	"02ED"H	"02EE"H	"02EF"H																							
Gn=4	"0300"H	"0301"H	"0302"H	"0303"H	"03EC"H	"03ED"H	"03EE"H	"03EF"H																							
Gn=5	"0400"H	"0401"H	"0402"H	"0403"H	"04EC"H	"04ED"H	"04EE"H	"04EF"H																							
⋮	⋮	⋮	⋮	⋮		⋮	⋮	⋮	⋮																							
Gn=92	"5B00"H	"5B01"H	"5B02"H	"5B03"H	"5BEC"H	"5BED"H	"5BEE"H	"5BEF"H																							
Gn=93	"5C00"H	"5C01"H	"5C02"H	"5C03"H	"5CEC"H	"5CED"H	"5CEE"H	"5CEF"H																							
Gn=94	"5D00"H	"5D01"H	"5D02"H	"5D03"H	"5DEC"H	"5DED"H	"5DEE"H	"5DEF"H																							
Gn=95	"5E00"H	"5E01"H	"5E02"H	"5E03"H	"5EEC"H	"5EED"H	"5EEE"H	"5EEF"H																							
Gn=96	"5F00"H	"5F01"H	"5F02"H	"5F03"H	"5FEC"H	"5FED"H	"5FEE"H	"5FEF"H																							

8.4 INTERFACE TIMING

8.4.1 CLOCK SYNCHRONIZED SERIAL INTERFACE TIMING CHARACTERISTICS

[VCC = 2.5 V to 3.3 V, VCCIO = 1.65 V to 3.3 V]

Item		Symbol	Unit	Min	Typ	Max
Serial Clock Cycle Time	Write	tSCYCW	μs	0.11	-	19
	Read	tSCYCR	μs	0.53	-	19
Serial Clock "High" Level Pulse Width	Write	tSCHW	ns	37	-	-
	Read	tSCHR	ns	210	-	-
Serial Clock "Low" Level Pulse Width	Write	tSCLW	ns	37	-	-
	Read	tSCLR	ns	270	-	-
Serial Clock Rise/Fall Time		tscr, tscf	ns	-	-	14
Chip Select Setup Time		tCSU	ns	-1	-	-
Chip Select Hold Time		tCH	ns	-1	-	-
Serial Input Data Setup Time		tSISU	ns	32	-	-
Serial Input Data Hold Time		tSIH	ns	32	-	-
Serial Output Data Delay Time		tSOD	ns	-	-	190
Serial Output Data Hold Time		tSOH	ns	6	-	-

8.4.2 RGB INTERFACE TIMING CHARACTERISTICS

[VCC = 2.5 V to 3.3 V, VCCIO = 1.65 V to 2.5 V]

Item	Symbol	Unit	Min	Typ	Max
VSYNC Setup Time	TVS	μs	11	-	-
VSYNC Hold Time	TVH	μs	11	-	-
HSYNC Setup Time	THS	ns	11	-	-
HSYNC Hold Time	THH	ns	11	-	-
DOTCLK "Low" Level Pulse Width	TLWD	ns	16	-	-
DOTCLK "High" Level Pulse Width	THWD	ns	16	-	-
DOTCLK Cycle Time	tCYCD	ns	105	-	-
Data Setup Time	tDS	ns	11	-	-
Data Hold Time	tDH	ns	11	-	-
Rise/Fall Time	Tr/Tf	ns	-	-	4

8.4.3 RESET TIMING CHARACTERISTICS

[VCC = 2.5 V to 3.3 V, VCCIO = 1.65 V to 3.3 V]

Item	Symbol	Unit	Min	Typ	Max
Reset "Low" Level Width	tRES	ms	1	-	-
Reset Rise Time	trRES	μs	-	-	10

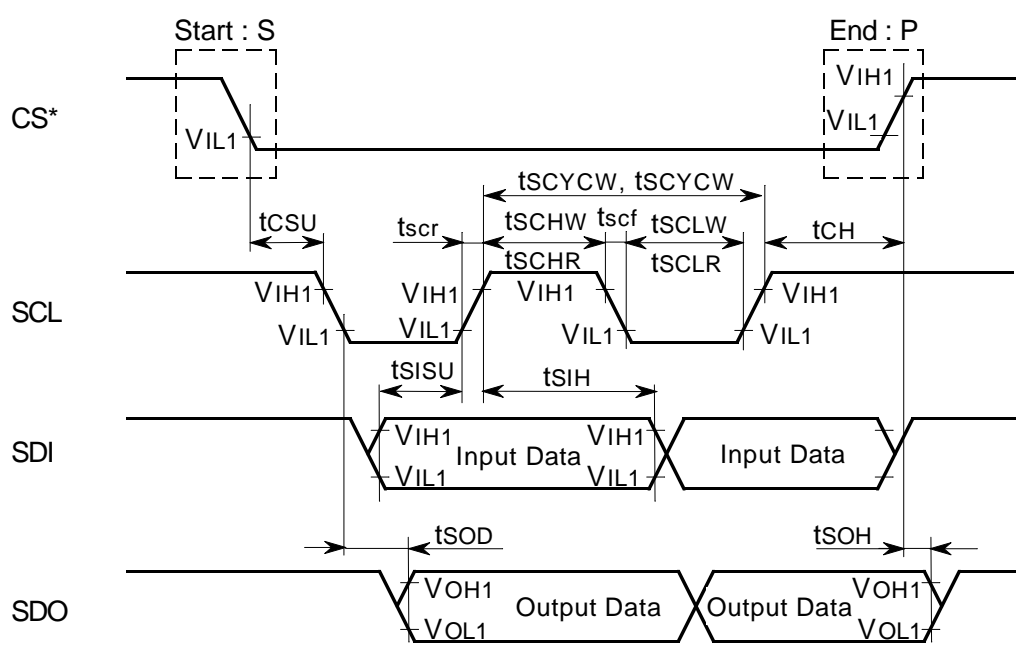

Clock Synchronized Serial Interface (SPI) Timing

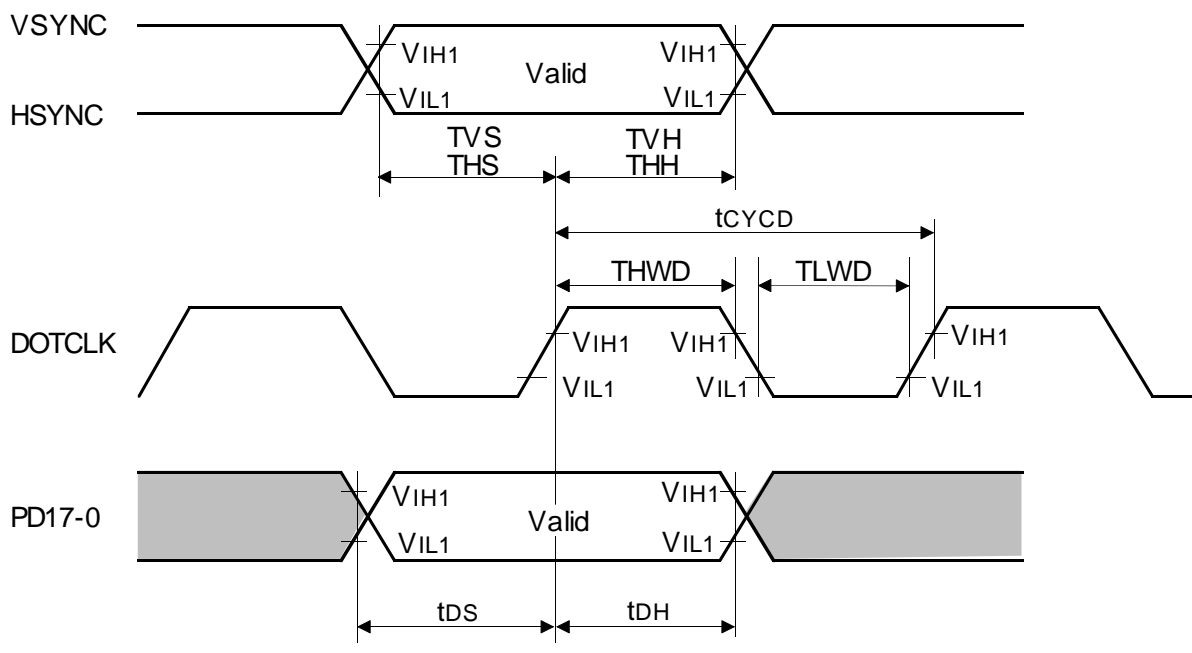

RGB Interface Timing

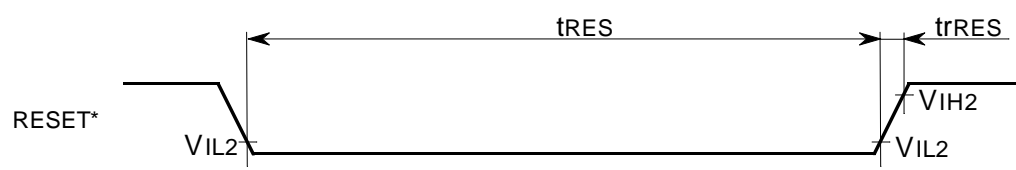

Reset Timing

8.4.4 16-bit/18-bit RGB INTERFACE TIMING

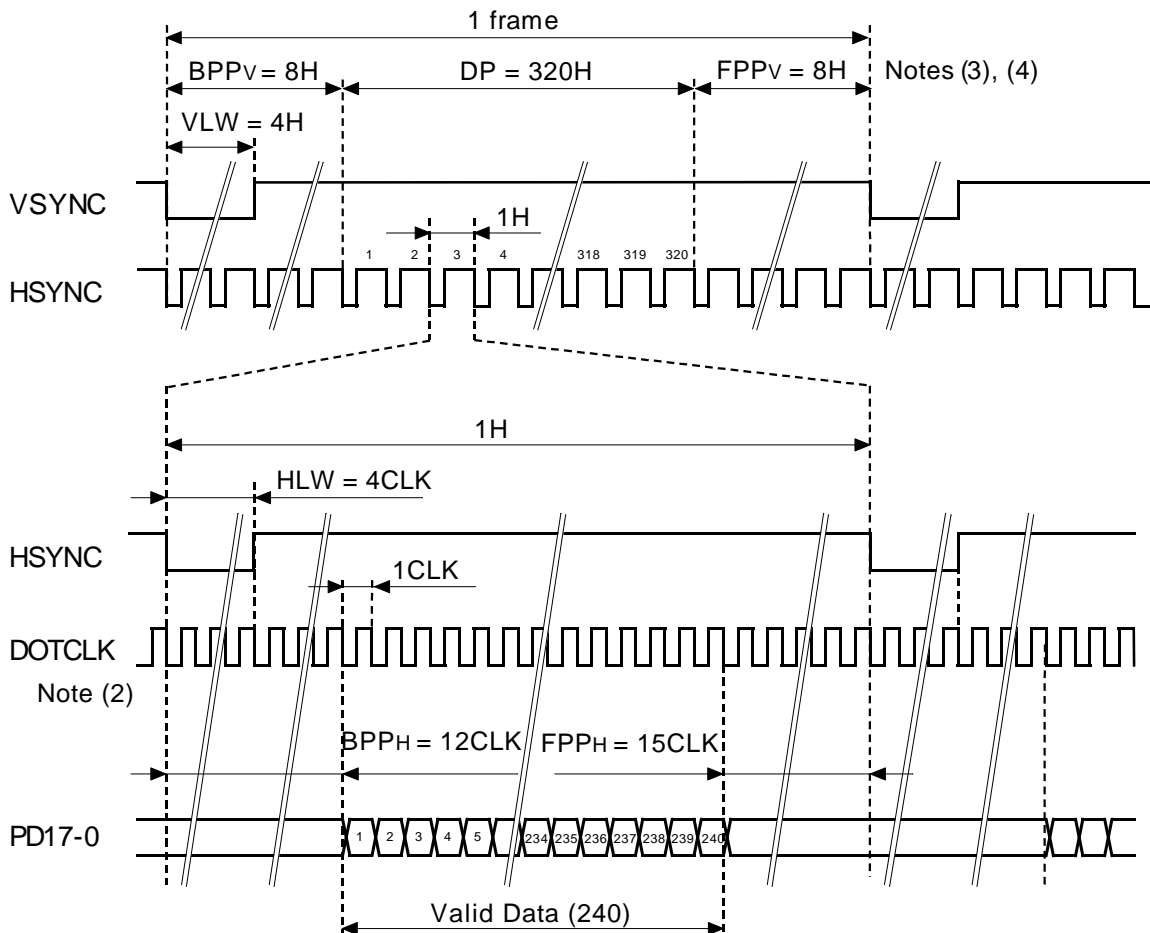

FPP : Front porch period
 BPP : Back porch period
 DP : Display operation period

VLW : The period in which VSYNC is low level
 HLW : The period in which HSYNC is low level

Item	Min	Typ	Max	Note
HLW	1CLK	4CLK	-	HLW ≥ 1CLK
BPPH	10CLK	12CLK	20CLK	(5)
FPPH	10CLK	15CLK	100CLK	-
VLW	1H	4H	-	-
BPPV	3H	8H	15H	(3), (5)
FPPV	-	8H	-	(3), (4)
DP	-	-	320H	-
fFLM	(75)	85	(95)	-

The number of raster-rows of 1 frame : $BPPV + DP + FPPV$
 $f_{DOTCLK} = f_{FLM} \times (320 + BPPV + FPPV) \times (240 + BPPH + FPPH)$

Notes

- (1) RGB-I/F mode should be used with the high-speed write mode (HWM = "1").
- (2) Dot clock signal (DOTCLK) must be always supplied.
- (3) Front and back porch periods must be set before and after the display operation period (DP).
- (4) Front porch period continues until the next input of VSYNC signal.
- (5) Horizontal and vertical back porch periods (BPPH, BPPV) of interface signal must accord with R05h register setting value.

8.5 REGISTER SETTING FLOW

8.5.1 STATE CHART

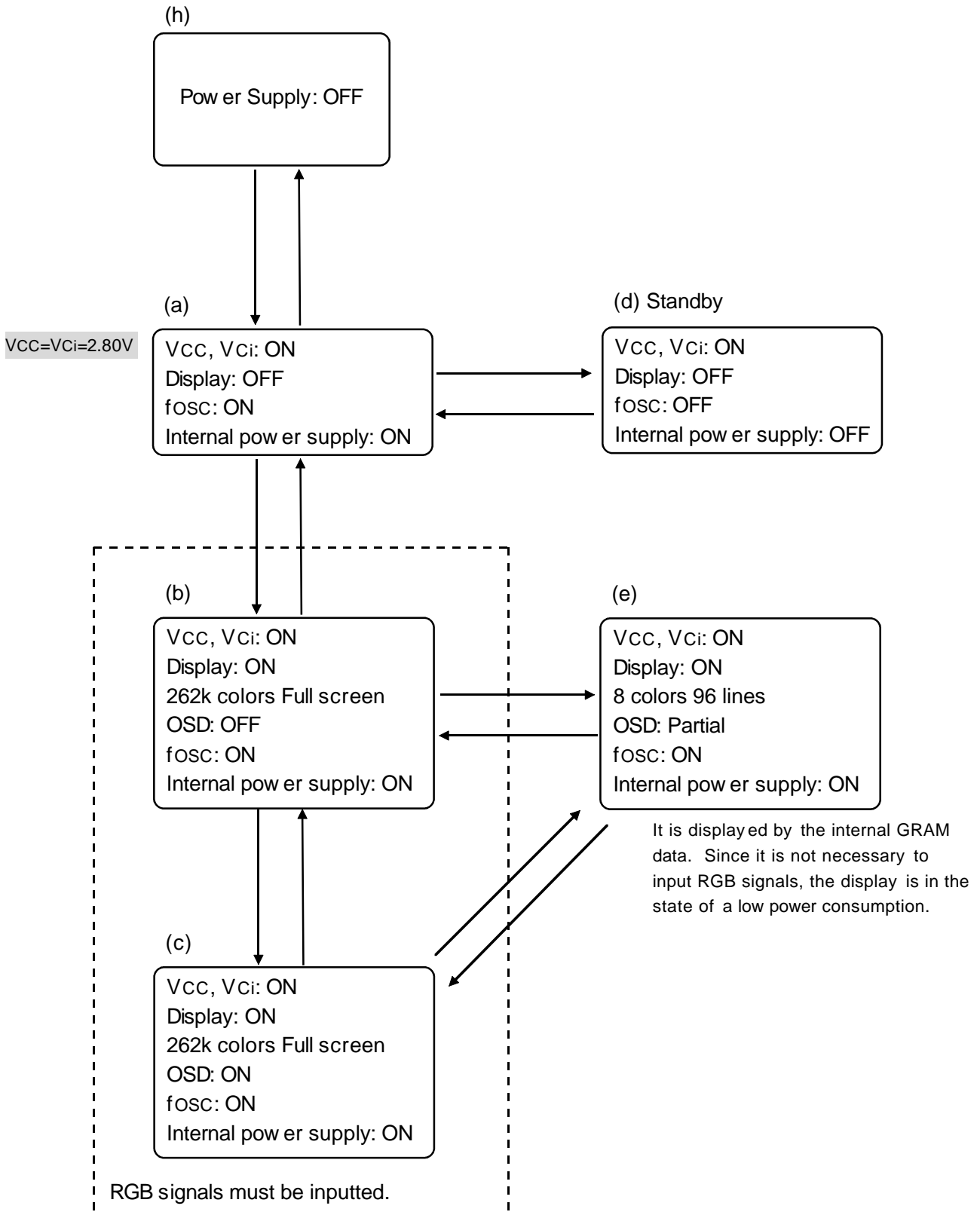

8.5.2 SEQUENCE

Status (h) ---> (a)

1	Power On reset	Reset* = "L"
2		VccIO On
3		Vci On
4		wait 1 ms
5		Reset* = "H"
6		wait 1 ms
7	Oscillation Start	R00h 0x01
8		wait 10 ms

Status (a) ---> (h)

1	Power Off	Vci Off
2		VccIO Off

Status (a) ---> (d)

1	idx=000 0x1000	R40h	0x00
2		R41h	0x80
3		R42h	0x00
4		R40h	0x10
5		wait	100 us
6		R50h	0x01

Status (d) ---> (a)

1	R00h	0x01
2	wait	10 ms
3	R50h	0x00
4	wait	100 us

Status (b) ---> (c)

1		R04h	0x02
2		wait	40 ms
3		R0Ah	0x1B
4	OSD area 1 Line setting	R0Bh	0x00
5	Start line (1)	R0Ch	0x00
6	OSD area 2 Line setting	R0Dh	0x11
7	Start line (279)	R0Eh	0x06
8		R30h	0x00
9		R31h	0xEF
10		R32h	0x00
11		R33h	0x5F
12	OSD area 1 RAM setting	R34h	0x00
13	54 lines from 00h to 35h	R35h	0x35
14	OSD area 2 RAM setting	R36h	0x36
15	42 lines from 36h to 5Fh	R37h	0x5F
16	Serial I/F writing	R20h	0x00
17		R21h	0x00
18		R23h	0x36
19		R22h	-
20		Image write (240x96)	
21		R04h	0x03

Status (c) ---> (b)

1	R0Ah	0x00
---	------	------

Status (e) ---> (c)

1		RGB input ON	
2		R04h	0x02
3		wait	40 ms
4	idx=001 0x1223	R40h	0x01
5		R41h	0x91
6		R42h	0x03
7		R40h	0x11
8		wait	100 us
9	idx=011 0x0CCF	R40h	0x03
10		R41h	0x66
11		R42h	0x0F
12		R40h	0x13
13		wait	100 us
14		R03h	0x00
15		R50h	0x34
16		R51h	0x00
17	idx=010 0x0A04	R40h	0x02
18		R41h	0x50
19		R42h	0x04
20		R40h	0x12
21		wait	100 us
22	idx=000 0x1174	R40h	0x00
23		R41h	0x8B
24		R42h	0x14
25		R40h	0x10
26		wait	100 us
27		R0Ah	0x1B
28		R04h	0x03
29		wait	40 ms

Status (c) ---> (e)

1		R04h	0x82
2		wait	40 ms
3		R0Ah	0x5B
4	idx=001 0x0046	R40h	0x01
5		R41h	0x02
6		R42h	0x06
7		R40h	0x11
8		wait	100 us
9	idx=011 0x0DC0	R40h	0x03
10		R41h	0x6E
11		R42h	0x00
12		R40h	0x13
13		wait	100 us
14	idx=010 0x0F04	R40h	0x02
15		R41h	0x78
16		R42h	0x04
17		R40h	0x12
18		wait	100 us
19	idx=000 0x1072	R40h	0x00
20		R41h	0x83
21		R42h	0x12
22		R40h	0x10
23		wait	100 us
24		R03h	0x00
25		R07h	0x80
26		R50h	0x24
27		R51h	0x30
28		wait	40 ms
29		R04h	0x83
30		wait	40 ms
31		RGB input OFF	

Status (a) ---> (b)

1		RGB input ON		42		R03h	0x00
2		R05h	****	43	Follow LCDC settings.	R09h	0xF4
3		R50h	0x00	44		R0Ah	0x00
4		R51h	0x00	45		R0Bh	0x00
5	idx=000 0x0000	R40h	0x00	46		R0Ch	0x00
6		R41h	0x00	47		R0Dh	0x00
7		R42h	0x00	48		R0Eh	0x00
8		R40h	0x10	49		R34h	0x00
9		wait	100 us	50		R35h	0x00
10	idx=010 0x0A04	R40h	0x02	51		R36h	0x00
11		R41h	0x50	52		R37h	0x00
12		R42h	0x04	53		R04h	0x01
13	idx=011 0x0CCF	R40h	0x12	54	Gamma setting	R60h	0x74
14		wait	100 us	55		R61h	0x51
15		R40h	0x03	56		R62h	0x05
16		R41h	0x66	57		R63h	0x23
17		R42h	0x0F	58		R64h	0x33
18	R40h	0x13	59	R65h		0x15	
19	wait	100 us	60	R66h		0x03	
20	idx=001 0x1223	R40h	0x01	61		R67h	0x06
21		R41h	0x91	62		R68h	0x00
22		R42h	0x03	63		R69h	0x62
23	idx=110 0x19C0	R40h	0x11	64	R6Ah	0x30	
24		wait	100 us	65	R6Bh	0x13	
25		R40h	0x06	66	R6Ch	0x35	
26		R41h	0xCE	67	R6Dh	0x23	
27		R42h	0x00	68	R6Eh	0x03	
28	R40h	0x16	69	R6Fh	0x05		
29	wait	100 us	70	R70h	0x00		
30		R50h	0x34	71	R71h	0x06	
31	idx=000 0x0044	R51h	0x00	72	idx=000 0x1174	R40h	0x00
32		R40h	0x00	73		R41h	0x8B
33		R41h	0x02	74		R42h	0x14
34		R42h	0x04	75		R40h	0x10
35		R40h	0x10	76		wait	100 us
36	wait	20 ms	77	R23h	0x36		
37	idx=000 0x0174	R40h	0x00	78	R04h	0x03	
38		R41h	0x0B	79	wait	1 ms	
39		R42h	0x14	80	R06h	0x10	
40		R40h	0x10				
41	wait	20 ms					

to Sequence No.42

Status (b) ----> (a)

1		R04h	0x02
2		wait	40 ms
3		R06h	0x00
4		wait	40 ms
5	idx=000 0x0174	R40h	0x00
6		R41h	0x0B
7		R42h	0x14
8		R40h	0x10
9		wait	100 us
10		R04h	0x00
11		R06h	0x00
12		R50h	0x00
13	idx=000 0x0010	R40h	0x00
14		R41h	0x00
15		R42h	0x10
16		R40h	0x10
17		wait	10 ms
18	idx=000 0x0000	R40h	0x00
19		R41h	0x00
20		R42h	0x00
21		R40h	0x10
22		wait	10 ms
23		RGB input OFF	

Status (e) ----> (b)

1		RGB input ON	
2		R04h	0x02
3		wait	40 ms
4	idx=001 0x1223	R40h	0x01
5		R41h	0x91
6		R42h	0x03
7		R40h	0x11
8		wait	100 us
9	idx=011 0x0CCF	R40h	0x03
10		R41h	0x66
11		R42h	0x0F
12		R40h	0x13
13		wait	100 us
14		R03h	0x00
15		R50h	0x34
16		R51h	0x00
17	idx=000 0x1174	R40h	0x00
18		R41h	0x8B
19		R42h	0x14
20		R40h	0x10
21		wait	100 us
22	idx=010 0x0A04	R40h	0x02
23		R41h	0x50
24		R42h	0x04
25		R40h	0x12
26		wait	100 us
27		R0Ah	0x00
28		R04h	0x03
29		wait	40 ms

Status (b) ----> (e)

1		R04h	0x82
2		wait	40 ms
3		R0Ah	0x5B
4	idx=001 0x0046	R40h	0x01
5		R41h	0x02
6		R42h	0x06
7		R40h	0x11
8		wait	100 us
9	idx=011 0x0CC0	R40h	0x03
10		R41h	0x66
11		R42h	0x00
12		R40h	0x13
13		wait	100 us
14	idx=010 0x0F04	R40h	0x02
15		R41h	0x78
16		R42h	0x04
17		R40h	0x12
18		wait	100 us
19	idx=000 0x1072	R40h	0x00
20		R41h	0x83
21		R42h	0x12
22		R40h	0x10
23		wait	100 us
24		R03h	0x00
25		R07h	0x80
26		R50h	0x24
27		R51h	0x30
28	OSD area 1 Line setting Start line (1)	R0Bh	0x00
29		R0Ch	0x00
30	OSD area 2 Line setting Start line (279)	R0Dh	0x11
31		R0Eh	0x06
32		R30h	0x00
33		R31h	0xEF
34		R32h	0x00
35		R33h	0x5F
36	OSD area 1 RAM setting 54 lines from 00h to 35h	R34h	0x00
37		R35h	0x35
38	OSD area 2 RAM setting 42 lines from 36h to 5Fh	R36h	0x36
39		R37h	0x5F
40	Serial I/F writing	R20h	0x00
41		R21h	0x00
42		R23h	0x36
43		R22h	-
44		Image write (240x96)	
45		R04h	0x83
46		wait	40 ms
47		RGB input OFF	

9. DIMENSIONAL OUTLINE

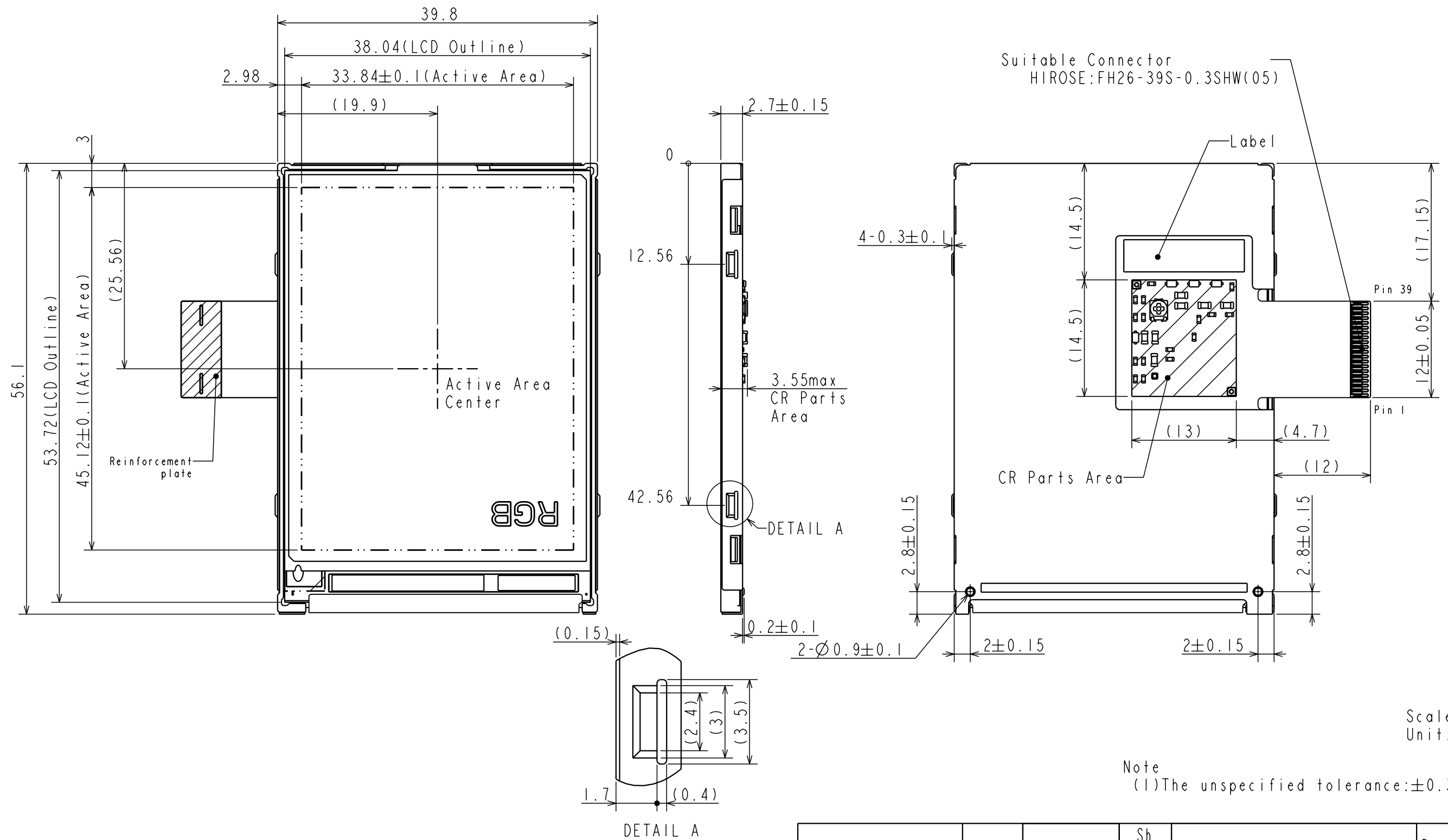

Scale: NTS
Unit: mm

Note
(1) The unspecified tolerance: ±0.3

Hitachi Displays, Ltd.	Date	June 8, 2006	Sh. No.	3284PS26 09-TX06D57VM0AAA-1A	Page	9-1/1
------------------------	------	--------------	---------	------------------------------	------	-------

10. VISUAL INSPECTION

10.1 INSPECTION CONDITION

- (1) Ambient illumination : 1000 - 1500 [lx]
- (2) Distance between inspector's eyes and LCD Module : Approximately 30 [cm]
- (3) Viewing angle : $\leq 30^\circ$
- (4) Refer to the Measurement Conditions described in Item 6.1 for the conditions other than specified here.

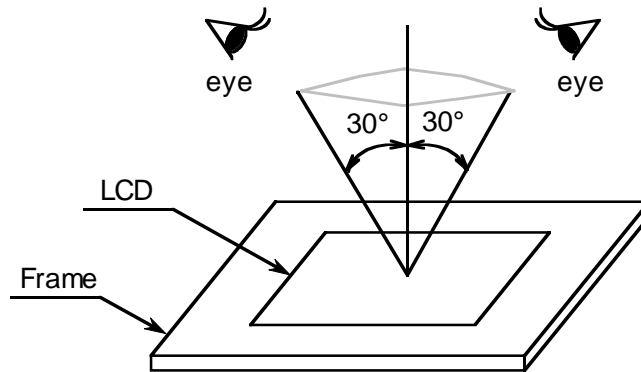

10.2 DEFINITION OF ZONE

The visual inspection zones of LCD Module is divided into three as follows.

A zone : Active Area (For dimensions, see Item 9, DIMENSIONAL OUTLINE.)

B zone : Viewing Area but Active Area (For dimensions, see Item 9, DIMENSIONAL OUTLINE.)

C zone : Whole LCD Module except the Viewing Area (Including FPC and frame)

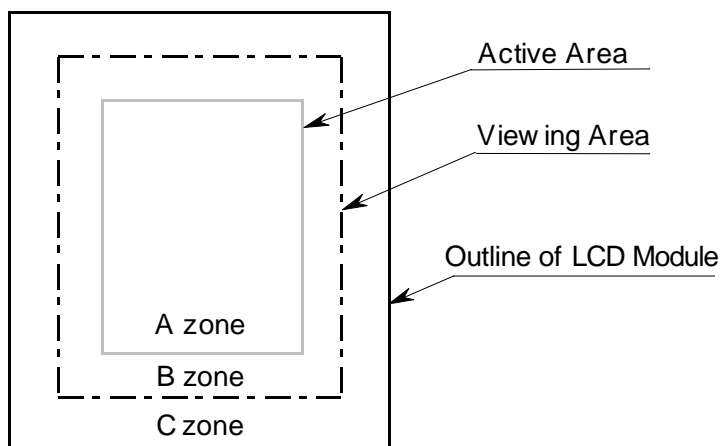

10.3 COSMETIC SPECIFICATION

No.	Item			Maximum Acceptable Number	Unit	Applied Zone	LCD module	Back light	Note
1	Dot Defect	Bright dot	1 dot	0	pc	A	On		(1), (2), (3), (4), (8)
			Adjacent dots	0	set				
		Dark dot	1 dot	2	pc				
			Adjacent dots	0	set				
	Total Number			2	pc				
2	Line Defect			0	-	A	On	-	
3	Uneven Brightness (Linear)			Serious one is not allow ed.	-	A	On	(6)	
4	Uneven Brightness (Circular)								
5	Foreign Particles, Stain (Linear) [mm] W: Width L: Length	W≤0.01	L: Ignored	Ignored	pc	A, B	On	(5), (6), (7), (8)	
		0.01<W≤0.05	L≤2.0	2					
			L>2.0	0					
0.05<W	-	Refer to No.6. (Judge w ith D.)							
6	Foreign Particles, Stain (Circular) [mm] D: Average diameter	D≤0.1		Ignored	pc	A, B	On	(5), (6), (7), (8)	
		0.1<D≤0.15		3					
		0.15<D≤0.2		2					
		0.2<D		0					
7	Scratch of Polarizer (Linear) [mm] W: Width, L: Length	W≤0.015	L: Ignored	Ignored	pc	A, B	Off	(5), (6), (7)	
		0.015<W ≤0.04	L≤5	2					
			L>5	0					
8	Scratch of Polarizer (Circular) [mm] D: Average diameter	D≤0.2		Ignored	pc	A, B	Off	(5), (6), (7)	
		D≤0.4		2					
		0.4<D		0					
9	Polarizer Bubble [mm] D: Average diameter	D≤0.15		Ignored	pc	A, B	Off	(5), (6), (7)	
		0.15<D≤0.2		2					
		0.2<D≤0.4		1					
		0.4<D		0					
10	Scratch, Dent in Frame			Serious one is not allow ed.	-	C	Off	(6)	
11	Scratch of FPC				-	C	Off	(6)	

- Notes
- (1) A defect whose area is more than 50% of the dot is regarded as a Dot Defect.
 - (2) A dot whose brightness at all black screen is more than 30% of a normal white dot is defined as a Bright Dot Defect.
 - (3) A defect whose brightness in all white screen is less than 60% of a normal white dot is defined as a Dark Dot Defect.
 - (4) Defective dots which are not adjacent are taken as a single Dot Defect each.
 - (5) Something which can be easily wiped off is disregarded as a defect.
 - (6) In case a problem arises, both parties should discuss needed items such as limit samples.
 - (7) Definitions for D, W and L are as follows.

Definition of D

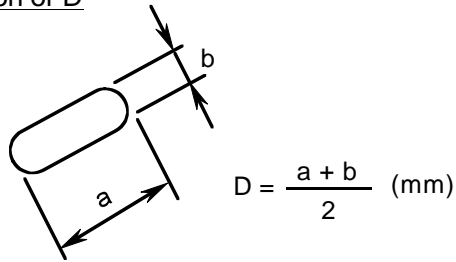

Definitions of W and L

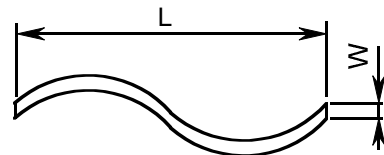

- (8) Distance between two defective dots is 10 mm minimum.

11. PRECAUTIONS IN DESIGN

11.1 GENERAL ATTENTION

- (1) The LCD module covered by this specification is designed as the display for mobile phone. When it is used for other purposes, we do not guarantee these specifications at all about the contents including quality and safety. Moreover, this module has not been particularly developed as an object for equipment in connection with a human life such as medical apparatus of life support relation.
- (2) Never attempt to disassemble this LCD module. There is danger such as a burn, an electric shock, and an injury. Moreover, when module is disassembled, we do not guarantee these specifications including quality and safety.

11.2 PRECAUTIONS AGAINST ELECTROSTATIC DISCHARGE

As this module contains C-MOS LSIs, it is not strong against electrostatic discharge. Make certain that the operator is grounded with suitable gear such as a wrist band. Pay attention not to touch terminal pins directly.

11.3 HANDLING PRECAUTIONS

- (1) Do not leave the LCD module in a humid environment for a long time. When the ambient temperature is over 35 degrees C in storage, please avoid high humidity. The polarizer can be deteriorated in high temperatures and high humidity. Moreover, it is also the cause of bubble and peeling of polarizer. Please store/operate the LCD module within the specified temperatures and normal humidity.
- (2) Since the polarizer tends to be easily scratched, the LCD module should be handled with full care so as not to get them touched, pushed or rubbed by a piece of glass, tweezers and anything else which is harder than a pencil lead 3H.
- (3) Maximum pressure to the surface must be 1.96 Pa. If the area to be given pressure is less than 1 cm², the pressure must be 1.96 N or less.
- (4) As the adhesives used for adhering upper and lower polarizers is an organic matter, it can be deteriorated by chemical reaction with such chemicals as acetone, toluene, ethanol and isopropyl alcohol. The following solvent is recommended for use: Normal hexane. Please contact us when it is necessary for you to use other chemicals than the above.
- (5) Lightly wipe a dirty surface with a clean soft material such as a cotton swab and a cloth for glasses, dampened with recommended chemicals without scrubbing it hardly. Always wipe the surface horizontally or vertically. Never give a wipe in a circle. To prevent the display surface from damage and to keep the appearance in good state, it is sufficient, in general, to wipe it with a cotton swab.
- (6) If spittle or a water drop comes in contact with the display area, immediately wipe it off. They can damage the display in some way including deformation and faded color.

Hitachi Displays, Ltd.	Date	June 8, 2006	Sh. No.	3284PS2611 - TX06D57VM0AAA - 1A	Page	11-1/3
------------------------	------	--------------	---------	---------------------------------	------	--------

- (7) Condensation on the LCD module may cause a damage, stain or dirt to the polarizer. When you need to take out the LCD module from some place at low temperature for test, etc., it is required to let them stand at room temperature before taking them out.
- (8) Touching the display area or the terminal pins with bare hands or contaminating them is prohibited because the stain on the display area and poor insulation between terminals are often caused by being touched with bare hands.
(Some cosmetics are detrimental to polarizers.)
- (9) As the display is made of glass, it is possible to be broken by a shock, especially its periphery can be easily cracked or chipped in handling. Please handle it with care and prevent it from being dropped.
- (10) Never bend nor scratch the interface part. Those actions can cause poor contacting.
- (11) Since the top and bottom areas of bent FPC tend to be easily damaged, be fully careful not to push or hold those areas.
- (12) Please do not apply local stress to the LCD module's back side. It has potential to add a scratch to the backlight guide, or to become a non-uniformity issue. Pay extra attention to the interface connector portion at the time of connector insertion.

11.4 OPERATION PRECAUTIONS

- (1) Spike noise can cause malfunction of the circuit. Recommended condition of spike noise level is as follows: $V_{cc} = \pm 200 \text{ mV}$ (over and under shoot voltage).
- (2) Response time depends on a temperature. (At a lower temperature, it becomes longer.)
And also brightness and color vary depending on a temperature.
- (3) Be careful for condensation at a sudden temperature change. Condensation can make damage to polarizers or electrical contacts. And after fading condensation, smear or a spot may occur.
- (4) When a fixed pattern is displayed at long times, afterimage is likely to occur.
- (5) As the LCD module has a high frequency circuit, take sufficient measures against electromagnetic noise, such as shielding your system.
- (6) Do not connect nor disconnect the module to or from main system with power applied.
- (7) Strong light exposure may cause malfunction of the driver.

11.5 STORAGE

When storing the LCD modules as spare parts for a long time, the following precautions are necessary.

- (1) Store the LCD modules in a dark place; do not expose them to sunlight or fluorescent light. Keep the temperature between 10 and 30 degrees C, and the humidity from 55% to 75%.
- (2) The polarizer surface should not come in contact with any other object. It is recommended that the LCD modules are stored in the container in which they were shipped.

11.6 SAFETY

This LCD module is a glass product. When it got damaged, be sure to wear a pair of protective gloves to deal it. Moreover, when any liquid leaked out of a damaged glass cell comes in contact with your skin, immediately wash it off well with soap and water.

11.7 MECHANICAL DESIGN

- (1) The design of the mobile phone case for this LCD module should be well studied so that any shock will not be added to the LCD module. When the case is dropped and the shock is not enough absorbed by the case, the LCD module may be broken.
- (2) To prevent foreign substances from entering, please apply a piece of polyurethane foam cushion, such as PORON, around the LCD.
Providing a cushion material such as PORON in the case will help LCD driver get less shock.

11.8 ENVIRONMENTAL PROTECTION

- (1) Abide by the national law, legislation and local regulation when disposing of this LCD module.
- (2) This LCD module complies with RoHS Directive.

Hitachi Displays, Ltd.	Date	June 8, 2006	Sh. No.	3284PS2611 - TX06D57VM0AAA - 1A	Page	11-3/3
------------------------	------	--------------	---------	---------------------------------	------	--------

12. DESIGNATION OF LOT MARK

LOT MARK

Lot mark is consisted of 11 digits x 2 line

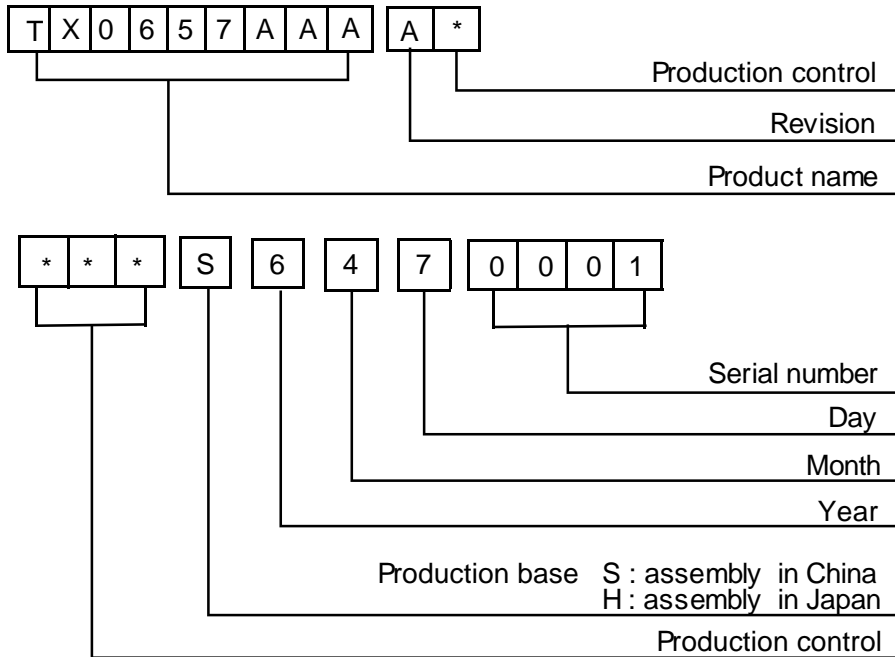

Revision	Contents of change
A	

Year	Figure in lot mark
2006	6
2007	7
2008	8

Month	Figure in lot mark	Month	Figure in lot mark
Jan.	1	July	7
Feb.	2	Aug.	8
Mar.	3	Sep.	9
Apr.	4	Oct.	A
May	5	Nov.	B
June	6	Dec.	C

Day	1	2	3	4	5	6	7	8	9
Figure in lot mark	1	2	3	4	5	6	7	8	9

Day	10	11	12	13	14	15	16	17	18	19
Figure in lot mark	A	B	C	D	E	F	G	H	J	K

Day	20	21	22	23	24	25	26	27	28	29
Figure in lot mark	L	M	N	P	Q	R	S	T	U	V

Day	30	31
Figure in lot mark	W	X

Production base	Figure in lot mark
Hitachi Displays	H
Hitachi Display Device (Suzhou)	S

Print example

TX0657AAAA0
001S6470001

13. PACKING SPECIFICATIONS

13.1 PLASTIC TRAY

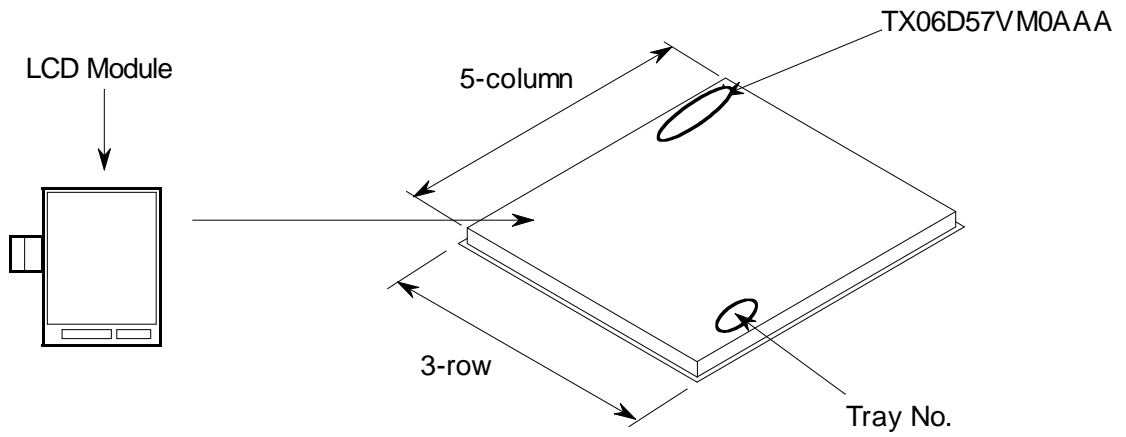

*Products should not run around on the tray.
 *Number of LCD module per tray: 15 pcs (5x3)

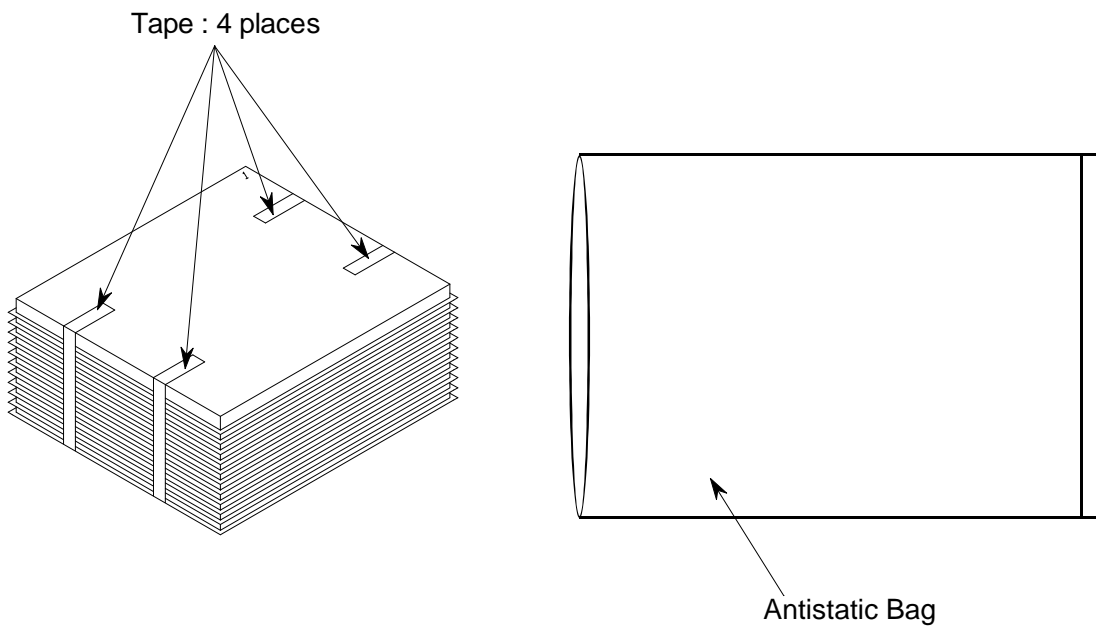

Tray: 11 trays are alternately turned and stacked.
 Top tray: No LCD Module, for top cover purpose

Eleven stacked trays are put in the antistatic bag.
 *Folded part of the bag is inserted under the tray.
 *Be careful not to damage a bag.

13.2 INNER BOX SPECIFICATIONS

Specification of packing in the inner box

- (1) Polyurethane foam cushion is put in a corrugated cardboard box.
- (2) Two antistatic bags holding 11 stacked trays each are placed in the box side by side.
- (3) A corrugated cardboard sheet is put on the trays.
- (4) Two more antistatic bags with trays are placed on the cardboard sheet.
- (5) Another polyurethane foam cushion is put them on.
- (6) The box is sealed with tape (in "I" shape).
- (7) In the case of a fraction, the space is filled up with a buffer material.

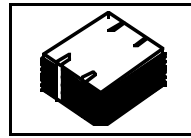
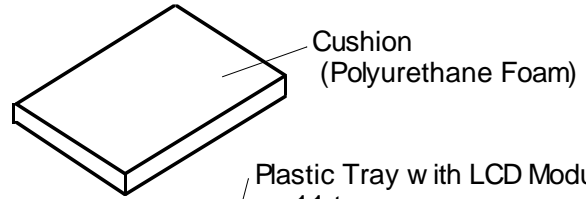

Plastic Tray with LCD Modules : 11 trays

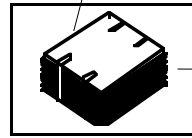

Antistatic Bag

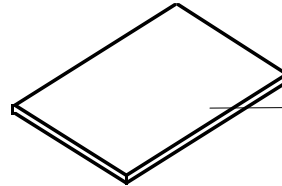

Corrugated Cardboard Sheet

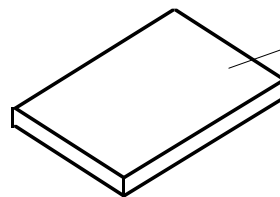
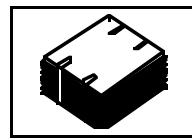
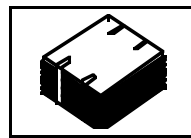

Cushion (Polyurethane Foam)

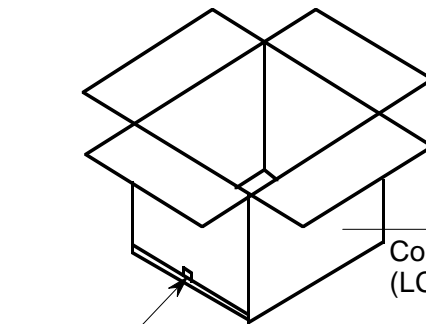

Corrugated Cardboard Box (LCD Module Capacity : 600 Max)

Tape ("H" shape)

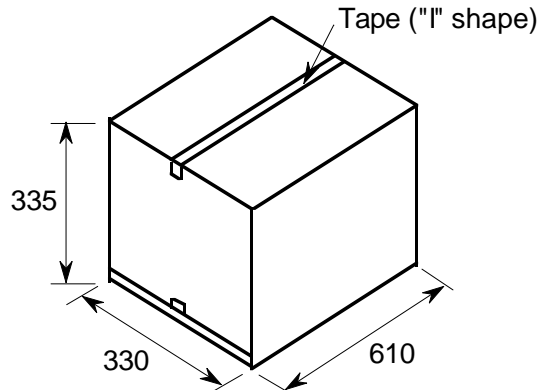

Unit : mm

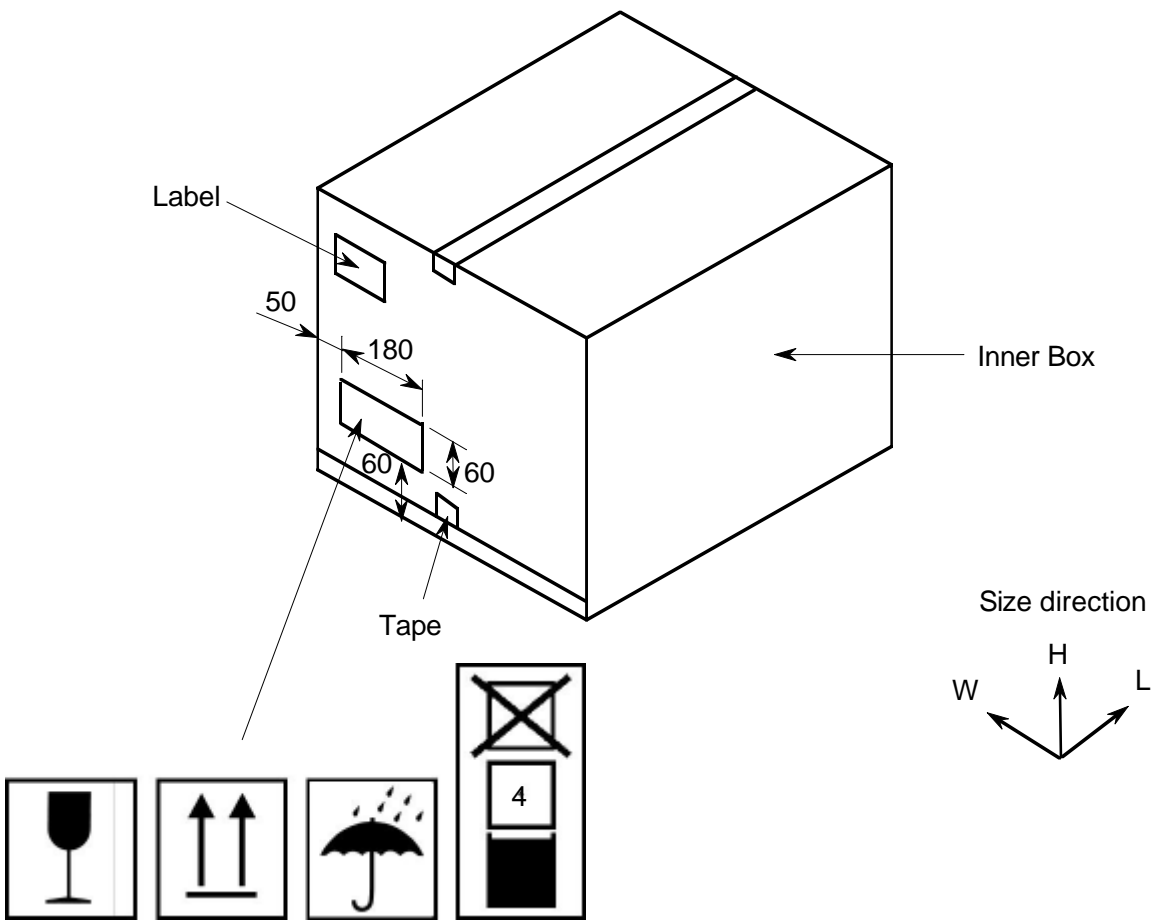

Size (L, W, H)	Approx. 610 x 330 x 335 mm
Quantity	1 to 600 pcs

13.3 OUTER BOX SPECIFICATIONS

An outer box is used only when the number of products is less than the minimum quantity for pallet.

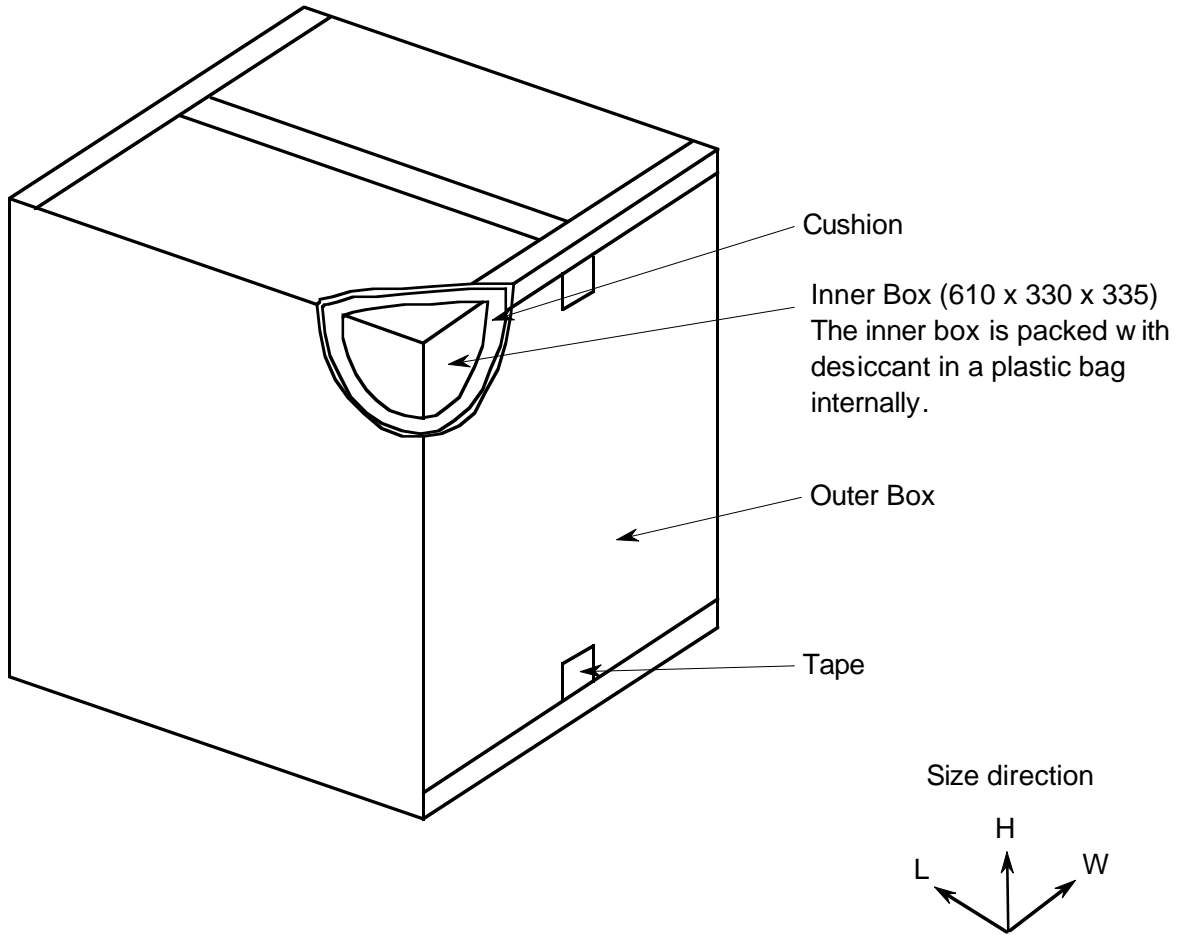

Weight (full load)	Approx. 13.4 kg
Size (L, W, H)	730 x 450 x 470 mm
Quantity	1 to 600 pcs

Two outer boxes are used if the quantity is between 601 and 1200.

Marking of Outer Box

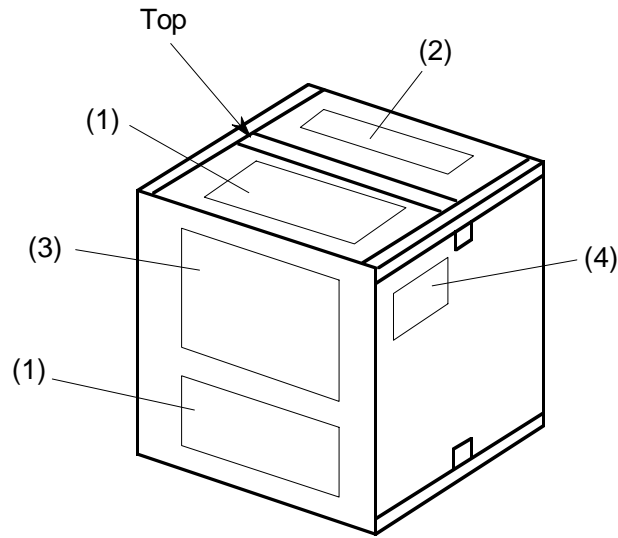

Markings are in red, except for a case mark.

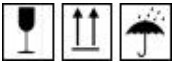
	Mark	Position
(1)	"FRAGILE HANDLE WITH CARE"	Top panel and both side panels
(2)	"GLASS"	Top panel
(3)	Case mark	One side panel
(4)		Both end panels

13.4 PALLET SPECIFICATIONS

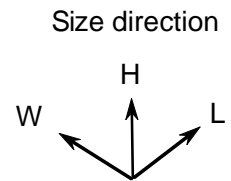
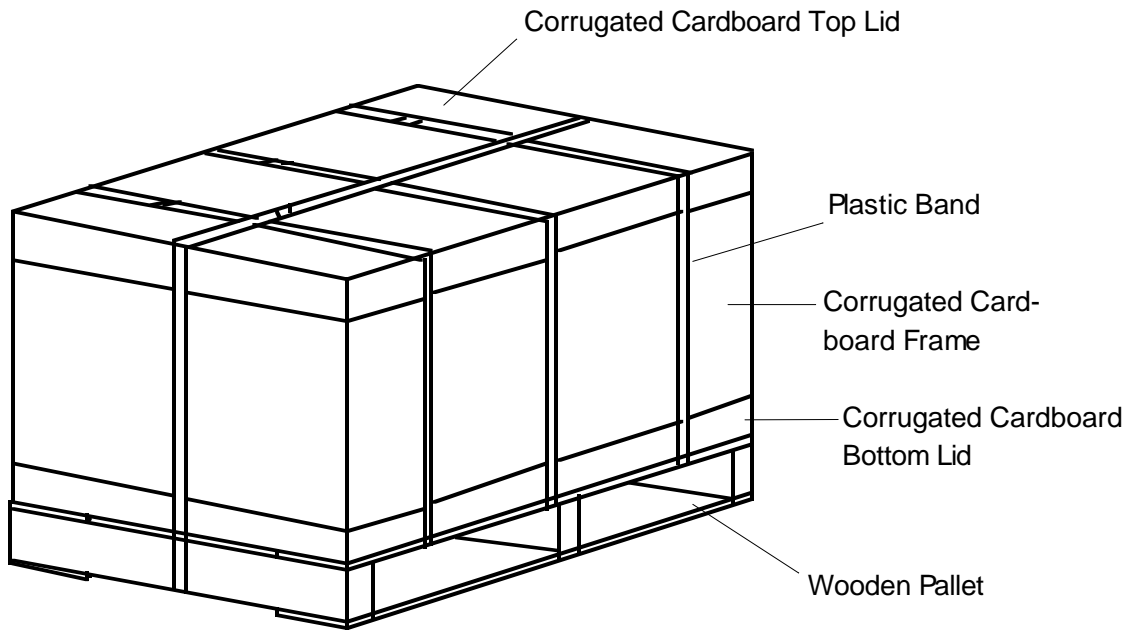

Weight (full load)	Approx. 99 kg
Size (L, W, H)	Approx. 1100 (typ) x 800 (typ) x 880 (max) mm
Quantity	1201 to 3600 pcs

Marking on Pallet Load

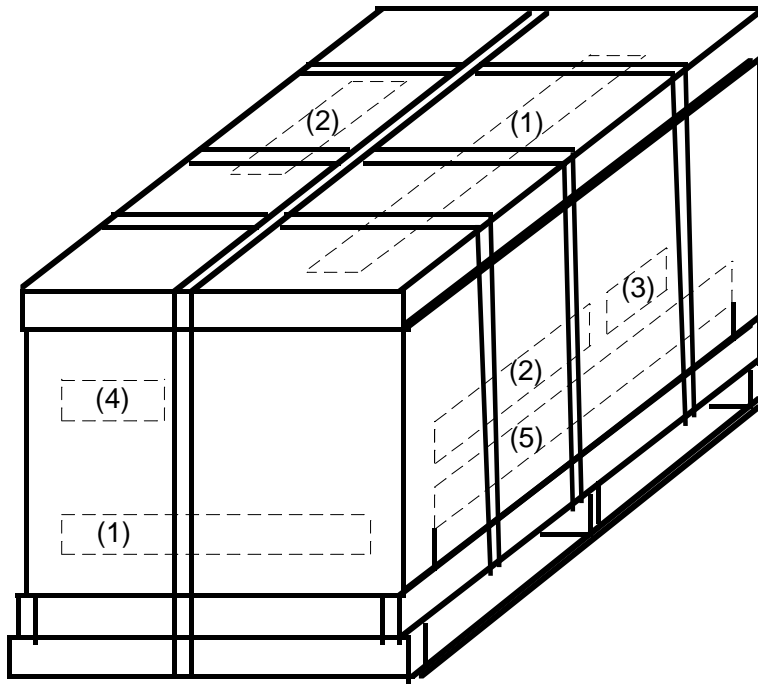

Markings are in red, except for a case mark.

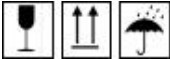
	Mark	Position
(1)	"FRAGILE HANDLE WITH CARE"	Top panel and both end panels
(2)	"GLASS"	Top panel and both side panels
(3)	Case mark	One side panel
(4)		Both end panels
(5)	"HANDLE WITH FORKLIFT TRUCK ONLY"	Both side panels

14. PRECAUTIONS FOR USE

- (1) A limit sample should be provided by the both parties on an occasion when the both parties agree to its necessity.

Judgment by a limit sample shall take effect after the limit sample has been established and confirmed by the both parties.

- (2) On the following occasions, the handling of the problem should be decided through discussion and agreement between responsible people of the both parties.

- a) When a question arises in the specifications.
- b) When a new problem which is not mentioned in the specifications occurs.
- c) When the customer changes any item of inspection specification or operating condition and reports it to Hitachi, and a problem in the specification arises because of the change.
- d) When a new problem is found with the customer's operating set for sample evaluation.