



TX1117

1A Bipolar LinearRegulator

Features

- Maximum output current is 1A
- Range of operation input voltage: Max 12V
- Line regulation: 0.1%/V (typ.)
- Standby current: 2mA (typ.)
- Load regulation: 10mV (typ.)
- Environment Temperature: -20 C~85 C

Applications

- Power Management for Computer Mother Board, Graphic Card
- LCD Monitor and LCD TV
- DVD Decode Board
- ADSL Modem
- Post Regulators For Switching Supplies

GENERAL DESCRIPTION

TX1117 is a series of low dropout three-terminal regulators with a dropout of 1.3V at 1A load current. TX1117 features a very low standby current 2mA compared to 5mA of competitor.

Other than a fixed version, $V_{out} = 1.2V, 1.8V, 2.5V, 3.3V, 5V,$ and 12V, TX1117 has an adjustable version, which can provide an output voltage from 1.25 to 12V with only two

external resistors.

TX1117 offers thermal shut down and current limit functions, to assure the stability of chip and power system. And it uses trimming technique to guarantee output voltage accuracy within 2%. Other output voltage accuracy can be customized on demand, such as 1%. TX1117 is available in SOT-223, TO-252 power package.

TYPICAL APPLICATION

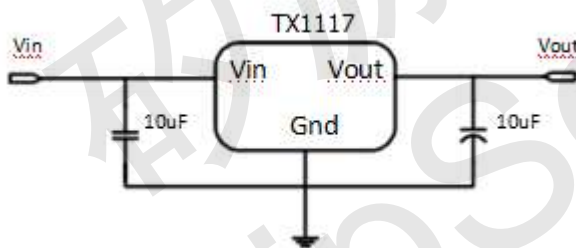

Application circuit of TX1117 fixed version

TYPICAL ELECTRICAL CHARACTERISTIC

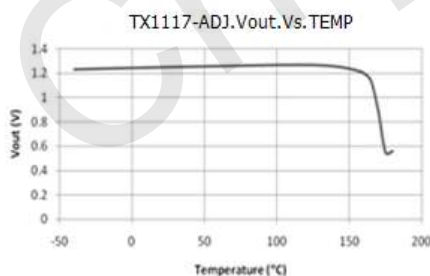



TX1117

1A Bipolar LinearRegulator

Selection Table

Marking	Part No.	Output Voltage	Package
1117 B XXYYZZ	XX=12	1.2V	SOT-223 TO-252
	XX=18	1.8V	
	XX=25	2.5V	
	XX=33	3.3V	
	XX=50	5.0V	
	XX=120	12.0V	
	XX=AD	Adjustable	

ORDERING INFORMATION

Marking	Designator	Description
1117 B XXYYZZ	1117	Product code
	B	Fab Code
	XX	Output Voltage(1.2~12.0V)
	YY	LOT NO.
	ZZ	DATA CODE

Note:"XX" stands for output voltages. Other voltages can be specially customized

Parameters	Description
Temperature&Rohs	C:-40~85℃ ,Pb Free Rohs Std.
Package type	L:SOT-223 O:TO-252
Packing type:	TR:Tape&Reel (Standard)
Voltage accuracy	1%(Customized)

Block Diagram



TX1117

1A Bipolar LinearRegulator

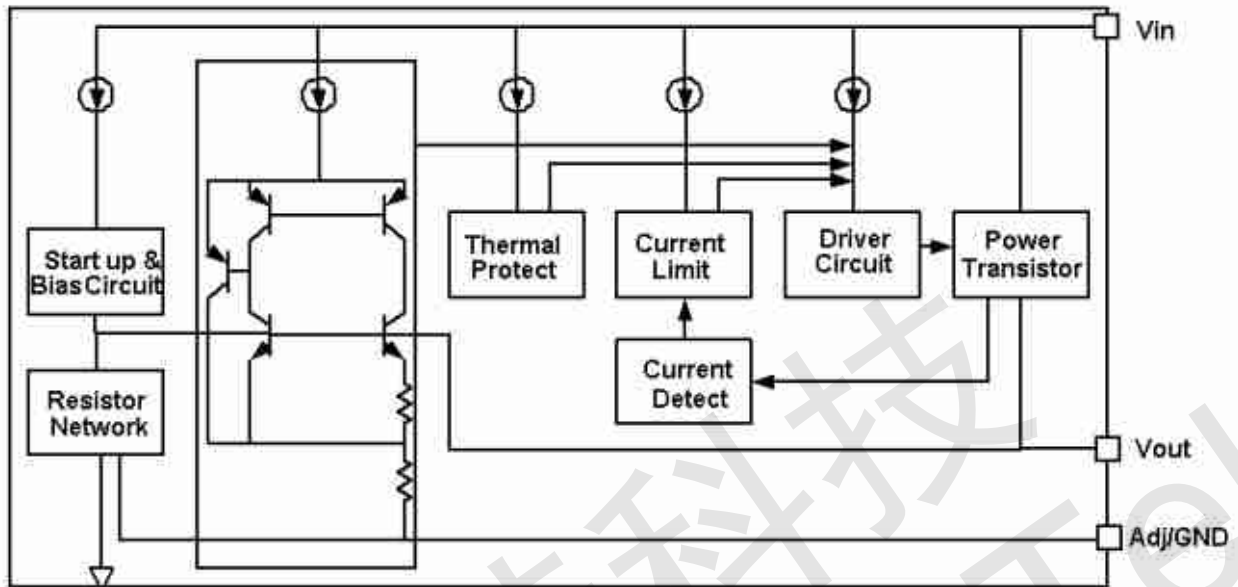

PIN CONFIGURATION

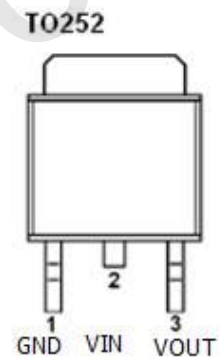
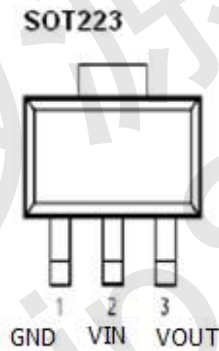

Absolute Maximum Ratings

Max Input Voltage	15V	°C ~ 85°C	Storage Temperature(Ts)	-40°C~150°C
Max Operating Junction Temperature(Tj)	150°C		Lead Temperature & Time	260°C 10S
Ambient Temperature(Ta)	-40			

Caution: Exceed these limits to damage to the device. Exposure to absolute maximum rating conditions may affect device reliability.

RECOMMENDED WORK CONDITIONS

Recommended maximum input



TX1117

1A Bipolar LinearRegulator

voltage..... 12V

Recommended operating junction

temperature(Tj)..... -20~125°C

Exceptional for TX1117-12V, the maximum input voltage for TX1117-12V is 20V.

Thermal Information

Parameter	Package	Rating	Unit
Package thermal resistance	SOT-223	20	°C/W
	TO-252	12.5	°C/W

Electrical Characteristics

Tj=25°C

Symbol	Parameter	Conditions	Min	Typ	Max	Unit
Vref	Reference voltage	TX1117-ADJ 10mA ≤ Iout ≤ 1A , Vin=3.25V	1.225	1.25	1.275	V
Vout	Output voltage	TX1117-1.2V 0 ≤ Iout ≤ 1A , Vin=3.2V	1.176	1.2	1.224	V
		TX1117-1.8V 0 ≤ Iout ≤ 1A , Vin=3.8V	1.764	1.8	1.836	V
		TX1117-2.5V 0 ≤ Iout ≤ 1A , Vin=4.5V	2.45	2.5	2.55	V
		TX1117-3.3V 0 ≤ Iout ≤ 1A , Vin=5.3V	3.234	3.3	3.366	V
		TX1117-5.0V 0 ≤ Iout ≤ 1A , Vin=7.0V	4.9	5	5.1	V
		TX1117-12.0V 0 ≤ Iout ≤ 1A , Vin=14V	11.76	12	12.24	V

ΔVout	Line regulation	TX1117-1.2V Iout=10mA, 2.7V ≤ Vin ≤ 10V		0.1	0.2	%/V
		TX1117-ADJ Iout=10mA, 2.75V ≤ Vin ≤ 12V		0.1	0.2	%/V
		TX1117-1.8V Iout=10mA, 3.3V ≤ Vin ≤ 12V		0.1	0.2	%/V
		TX1117-2.5V Iout=10mA, 4.0V ≤ Vin ≤ 12V		0.1	0.2	%/V
		TX1117-3.3V Iout=10mA, 4.8V ≤ Vin ≤ 12V		0.1	0.2	%/V
		TX1117-5.0V		0.1	0.2	%/V



TX1117

1A Bipolar LinearRegulator

		lout=10mA, 6.5V≤Vin≤12V				
		TX1117-1.8V		0.1	0.2	%/V
		lout=10mA, 13.5V≤Vin≤20V				

ΔVout	Load regulation	TX1117-1.2V Vin =2.7V, 10mA≤lout≤1A		10	30	mV
		TX1117-ADJ Vin =2.75V, 10mA≤lout≤1A		10	30	mV
		TX1117-1.8V Vin =3.3V, 10mA≤lout≤1A		10	30	mV
		TX1117-2.5V Vin =4.0V, 10mA≤lout≤1A		10	30	mV
		TX1117-3.3 Vin =4.8V, 10mA≤lout≤1A		10	30	mV
		TX1117-5.0 Vin =6.5V, 10mA≤lout≤1A		10	30	mV
		TX1117-12.0V Vin =13.5V, 10mA≤lout≤1A		10	30	mV
Vdrop	Dropout voltage	lout =100mA		1.23	1.3	V
		lout=1A		1.3	1.5	V
Ilimit	Current limit	Vin-Vout=2V;Tj =25℃	1			A
Imin	Minimum load current	TX1117-ADJ		2	10	mA
Iq	Quiescent Current	TX1117-1.2V,Vin=10V		2	5	mA
		TX1117-1.8V,Vin=12V		2	5	mA
		TX1117-2.5V,Vin=12V		2	5	mA
		TX1117-3.3V,Vin=12V		2	5	mA
		TX1117-5.0V,Vin=12V		2	5	mA
		TX1117-12.0V,Vin=20V		2	5	mA
IAdj	Adjust pin current	TX1117-ADJ Vin=5V,10mA≤lout≤1A		55	120	uA
Ichange	Iadj change	TX1117-ADJ Vin=5V,10mA≤lout≤1A		0.2	10	uA
ΔV/ΔT	Temperature coefficient			±100		ppm
θ _{JC}	Thermal resistance	SOT-223		20		℃/W
		TO-252		10		



TX1117

1A Bipolar LinearRegulator

		TO-220		4.5		
--	--	--------	--	-----	--	--

Note1: All test are conducted under ambient temperature 25° C and within a short period of time 20ms

Note2: Load current smaller than minimum load current of TX1117-ADJ will lead to unstable or oscillation output.

DETAILED DESCRIPTION

TX1117 is a series of low dropout voltage, three terminal regulators. Its application circuit is very simple: the fixed version only needs two capacitors and the adjustable version only needs two resistors and two capacitors to work. It is composed of some modules including start-up circuit, bias circuit, bandgap, thermal shutdown, current limit, power transistors and its driver circuit and so on.

The thermal shut down modules can assure chip and its application system working safety when the junction temperature is larger than 140°C.

The bandgap module provides stable reference voltage, whose temperature coefficient is compensated by careful design considerations. The temperature coefficient is under 100 ppm/°C. And the accuracy of output voltage is guaranteed by trimming technique.

TYPICAL APPLICATION

TX1117 has an adjustable version and six fixed versions (1.2V, 1.8V, 2.5V, 3.3V, 5V and 12V)

Fixed Output Voltage Version

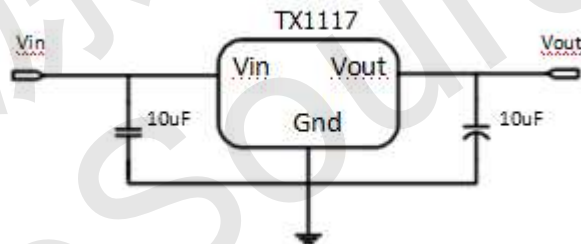

Application circuit of TX1117 fixed version

- 1) Recommend using 10uF tan capacitor as bypass capacitor (C1) for all application circuit.
- 2) Recommend using 10uF tan capacitor to assure circuit stability.

Adjustable Output Voltage Version

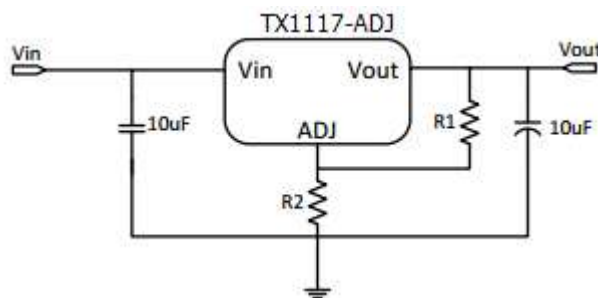



Application Circuit of TX1117-ADJ

The output voltage of adjustable version follows the equation: $V_{out}=1.25 \times (1+R_2/R_1)+I_{Adj} \times R_2$. We can ignore I_{Adj} because I_{Adj} (about 50uA) is much less than the current of R_1 (about 2~10mA).

1) To meet the minimum load current (>10mA) requirement, R_1 is recommended to be 125ohm or lower. As TX1117-ADJ can keep itself stable at load current about 2mA, R_1 is not allowed to be higher than 625ohm.

2) Using a bypass capacitor (C_{ADJ}) between the ADJ pin and ground can improve ripple rejection. This bypass capacitor prevents ripple from being amplified as the output voltage is increased. The impedance of C_{ADJ} should be less than R_1 to prevent ripple from being amplified. As R_1 is normally in the range of 100Ω~500Ω, the value of C_{ADJ} should satisfy this equation: $1/(2 \pi \times f_{ripple} \times C_{ADJ}) < R_1$.

THERMAL CONSIDERATIONS

We have to take heat dissipation into great consideration when output current or differential voltage of input and output voltage is large. Because in such cases, the power dissipation consumed by TX1117 is very large. TX1117 series uses SOT-223 package type and its thermal resistance is about 20°C/W. And the copper area of application board can affect the total thermal resistance. If copper area is 5cm*5cm (two sides), the resistance is about 30°C/W. So the total thermal resistance is about 20°C/W + 30°C/W. We can decrease total thermal resistance by increasing copper area in application board. When there is no good heat dissipation copper are in PCB, the total thermal resistance will be as high as 120°C/W, then the power dissipation of TX1117 could allow on itself is less than 1W. And furthermore, TX1117 will work at junction temperature higher than 125°C under such condition and no lifetime is guaranteed.

TYPICAL PERFORMANCE CHARACTERISTICS

T=25°C unless specified.

Line regulation

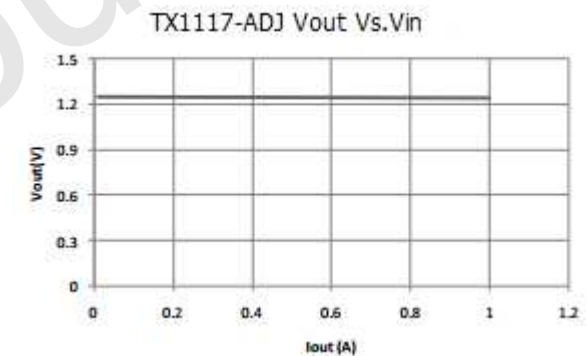
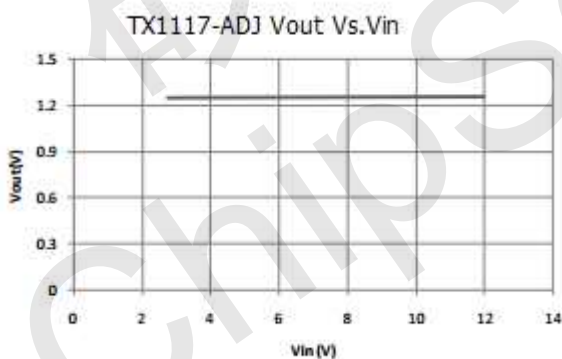

Dropout voltage

Load regulation



TX1117

1A Bipolar LinearRegulator

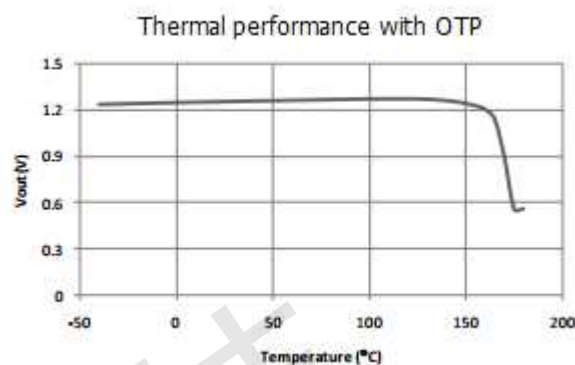
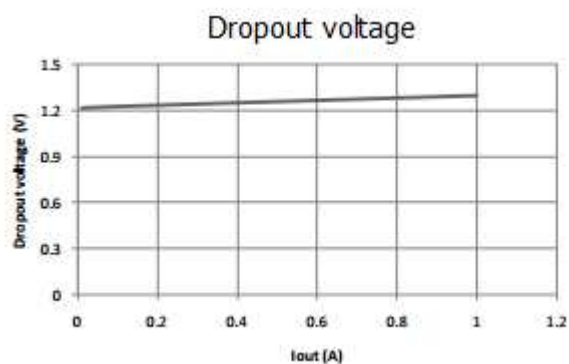

Thermal performance with OTP

PACKAGE OUTLINE

SOT-223 PACKAGE OUTLINE DIMENSIONS

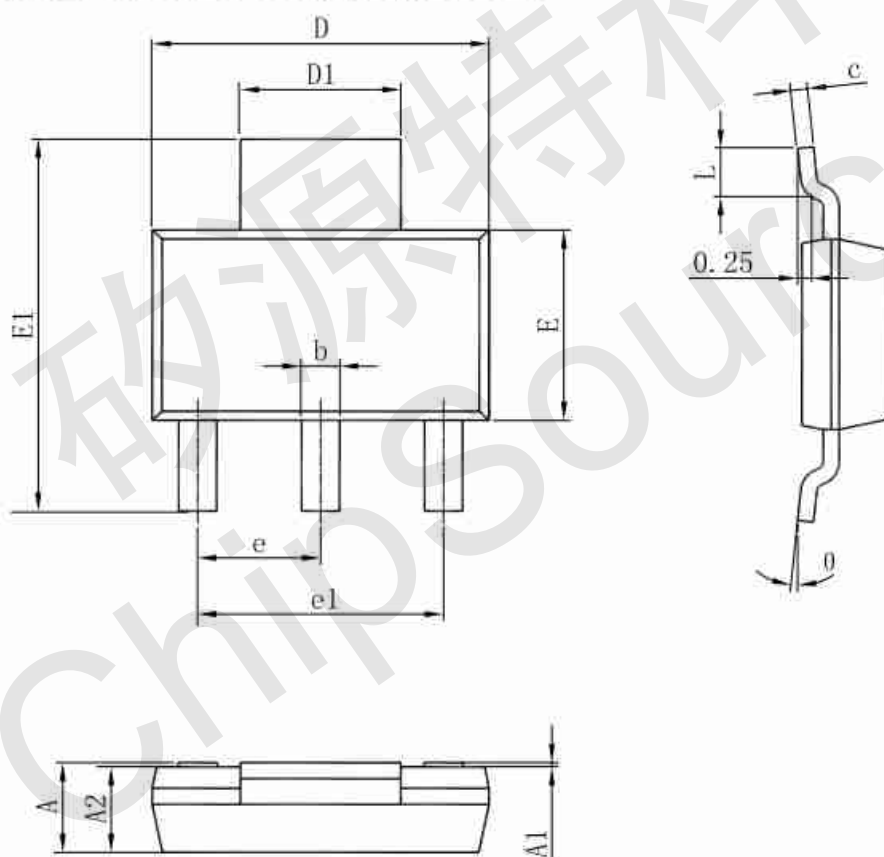



TX1117

1A Bipolar LinearRegulator

Symbol	Dimensions In Millimeters		Dimensions In Inches	
	Min	Max	Min	Max
A	1.520	1.800	0.060	0.071
A1	0.000	0.100	0.000	0.004
A2	1.500	1.700	0.059	0.067
b	0.660	0.820	0.026	0.032
c	0.250	0.350	0.010	0.014
D	6.200	6.400	0.244	0.252
D1	2.900	3.100	0.114	0.122
E	3.300	3.700	0.130	0.146
E1	6.830	7.070	0.269	0.278
e	2.300(BSC)		0.091(BSC)	
e1	4.500	4.700	0.177	0.185
L	0.900	1.150	0.035	0.045
θ	0°	10°	0°	10°



TX1117

1A Bipolar LinearRegulator

TO-252-2L PACKAGE OUTLINE DIMENSIONS

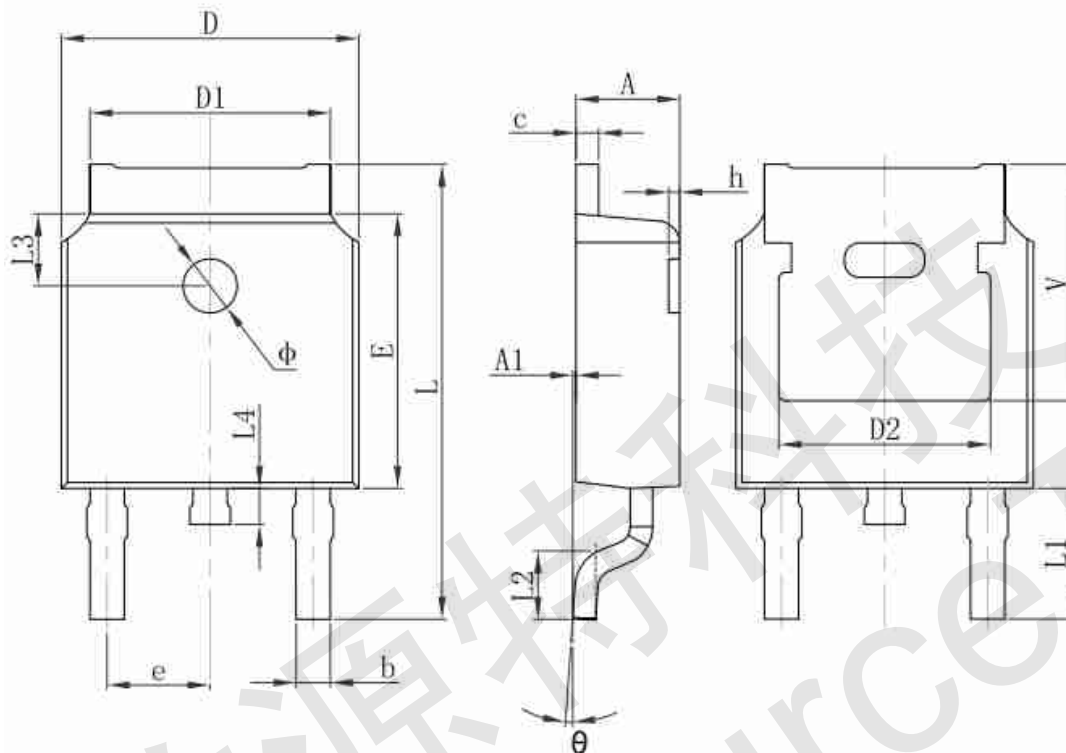

Symbol	Dimensions In Millimeters		Dimensions In Inches	
	Min.	Max.	Min.	Max.
A	2.200	2.400	0.087	0.094
A1	0.000	0.127	0.000	0.005
b	0.660	0.860	0.026	0.034
c	0.460	0.580	0.018	0.023
D	6.500	6.700	0.256	0.264
D1	5.100	5.460	0.201	0.215
D2	4.830 REF.		0.190 REF.	
E	6.000	6.200	0.236	0.244
e	2.186	2.386	0.086	0.094
L	9.800	10.400	0.386	0.409
L1	2.900 REF.		0.114 REF.	
L2	1.400	1.700	0.055	0.067
L3	1.600 REF.		0.063 REF.	
L4	0.600	1.000	0.024	0.039
Φ	1.100	1.300	0.043	0.051
θ	0°	8°	0°	8°
h	0.000	0.300	0.000	0.012
V	5.350 REF.		0.211 REF.	