

HITACHI

FOR MESSRS : _____

DATE : Nov.23,2007

CUSTOMER'S ACCEPTANCE SPECIFICATIONS TX11D01VM2APA CONTENTS

No.	ITEM	SHEET No.	PAGE
1	COVER	7B64PS 2701-TX11D01VM2APA-3	1-1/1
2	RECORD OF REVISION	7B64PS 2702-TX11D01VM2APA-3	2-1/2~2/2
3	GENERAL DATA	7B64PS 2703-TX11D01VM2APA-3	3-1/1
4	ABSOLUTE MAXIMUM RATINGS	7B64PS 2704-TX11D01VM2APA-3	4-1/2~2/2
5	ELECTRICAL CHARACTERISTICS	7B64PS 2705-TX11D01VM2APA-3	5-1/2~2/2
6	OPTICAL CHARACTERISTICS	7B64PS 2706-TX11D01VM2APA-3	6-1/2~2/2
7	BLOCK DIAGRAM	7B64PS 2707-TX11D01VM2APA-3	7-1/1
8	INTERFACE TIMING CHART	7B64PS 2708-TX11D01VM2APA-3	8-1/8~8/8
9	DIMENSIONAL OUTLINE	7B63PS 2709-TX11D01VM2APA-3	9-1/1
10	APPEARANCE STANDARD	7B64PS 2710-TX11D01VM2APA-3	10-1/5~5/5
11	PRECAUTION IN DESIGN	7B64PS 2711-TX11D01VM2APA-3	11-1/3~3/3
12	DESIGNATION OF LOT MARK	7B64PS 2712-TX11D01VM2APA-3	12-1/1
13	PRECAUTION FOR USE	7B64PS 2713-TX11D01VM2APA-3	13-1/1

* When product will be discontinued, customer will be informed by HITACHI with twelve months prior announcement.

ACCEPTED BY: _____

PROPOSED BY: *Dan Cheng*

KAOHSIUNG HITACHI ELECTRONICS CO.,LTD.	Sh. No.	7B64PS 2701-TX11D01VM2APA-3	PAGE	1-1/1
---	------------	-----------------------------	------	-------

RECORD OF REVISION

DATE	SHEET No.	SUMMARY																																
Aug.29,'07	7B64PS 2705 – TX11D01VM2APA-2 PAGE 5-1/2	5.1 ELECTRICAL CHARACTERISTICS OF LCD Revised <table border="1" style="margin: 5px 0;"> <thead> <tr> <th>ITEM</th> <th>MIN.</th> <th>TYP.</th> <th>MAX.</th> </tr> </thead> <tbody> <tr> <td>Vsync Frequency</td> <td>-</td> <td>(60)</td> <td>-</td> </tr> <tr> <td>Hsync Frequency</td> <td>-</td> <td>(17.14)</td> <td>-</td> </tr> <tr> <td>DCLK Frequency</td> <td>-</td> <td>(9.0)</td> <td>-</td> </tr> </tbody> </table> <p style="text-align: center;">↓</p> <table border="1" style="margin: 5px 0;"> <thead> <tr> <th>ITEM</th> <th>MIN.</th> <th>TYP.</th> <th>MAX.</th> </tr> </thead> <tbody> <tr> <td>Vsync Frequency</td> <td>56.2</td> <td>60</td> <td>79.2</td> </tr> <tr> <td>Hsync Frequency</td> <td>16.2</td> <td>17.14</td> <td>22.8</td> </tr> <tr> <td>DCLK Frequency</td> <td>8.5</td> <td>9.0</td> <td>12</td> </tr> </tbody> </table>	ITEM	MIN.	TYP.	MAX.	Vsync Frequency	-	(60)	-	Hsync Frequency	-	(17.14)	-	DCLK Frequency	-	(9.0)	-	ITEM	MIN.	TYP.	MAX.	Vsync Frequency	56.2	60	79.2	Hsync Frequency	16.2	17.14	22.8	DCLK Frequency	8.5	9.0	12
	ITEM	MIN.	TYP.	MAX.																														
Vsync Frequency	-	(60)	-																															
Hsync Frequency	-	(17.14)	-																															
DCLK Frequency	-	(9.0)	-																															
ITEM	MIN.	TYP.	MAX.																															
Vsync Frequency	56.2	60	79.2																															
Hsync Frequency	16.2	17.14	22.8																															
DCLK Frequency	8.5	9.0	12																															
7B64PS 2705 – TX11D01VM2APA-2 PAGE 5-2/2	5.3 ELECTRICAL CHARACTERISTICS OF TOUCH PANEL Revised <table border="1" style="margin: 5px 0;"> <thead> <tr> <th>ITEM</th> <th>SPECIFICATION</th> <th>UNIT</th> </tr> </thead> <tbody> <tr> <td rowspan="2">Resistance between Terminal</td> <td>XR-X</td> <td>430~1310</td> <td>ohm</td> </tr> <tr> <td>YU-YL</td> <td>70~350</td> <td>ohm</td> </tr> </tbody> </table> <p style="text-align: center;">↓</p> <table border="1" style="margin: 5px 0;"> <thead> <tr> <th>ITEM</th> <th>SPECIFICATION</th> <th>UNIT</th> </tr> </thead> <tbody> <tr> <td rowspan="2">Resistance between Terminal</td> <td>XR-X</td> <td>430~1310</td> <td>ohm</td> </tr> <tr> <td>YU-YL</td> <td>160~600</td> <td>ohm</td> </tr> </tbody> </table>	ITEM	SPECIFICATION	UNIT	Resistance between Terminal	XR-X	430~1310	ohm	YU-YL	70~350	ohm	ITEM	SPECIFICATION	UNIT	Resistance between Terminal	XR-X	430~1310	ohm	YU-YL	160~600	ohm													
ITEM	SPECIFICATION	UNIT																																
Resistance between Terminal	XR-X	430~1310	ohm																															
	YU-YL	70~350	ohm																															
ITEM	SPECIFICATION	UNIT																																
Resistance between Terminal	XR-X	430~1310	ohm																															
	YU-YL	160~600	ohm																															
7B64PS 2706 – TX11D01VM2APA-2 PAGE 6-1/2	6.1 OPTICAL CHARACTERISTICS OF LCD (BACK LIGHT ON) Revised some of optical characteristics and Note 2 (measurement places)																																	
7B64PS 2708 – TX11D01VM2APA-2 PAGE 8-4/8	8.3 POWER ON/OFF SEQUENCE Revised <div style="display: flex; justify-content: space-around; align-items: flex-start;"> <div style="text-align: center;"> <p>DVDD</p> <p>Signal</p> <p>2frame min.</p> </div> <div style="text-align: center;"> <p>(TBD) min.</p> </div> </div> <p style="text-align: center;">↓</p> <div style="display: flex; justify-content: space-around; align-items: flex-start;"> <div style="text-align: center;"> <p>DVDD</p> <p>Signal</p> <p>2frame min.</p> </div> <div style="text-align: center;"> <p>2 frame min.</p> </div> </div>																																	
7B64PS 2710 – TX11D01VM2APA-2 PAGE 10-2/5	10.3 APPEARANCE SPECIFICATION Revised some of Appearance Specification																																	

RECORD OF REVISION

DATE	SHEET No.	SUMMARY
Nov.23,'07	7B64PS 2708 – TX11D01VM2APA-3 PAGE 8-4/8	8.3 POWER ON/OFF SEQUENCE Revised
		9. DIMENSIONAL OULINE Modify Label potion from left side to right side.
		12. DESIGNATION OF LOT MARK Revised REV.A to REV.B for change frame metal of BL.

3.GENERAL DATA

The specifications are applied to the following 4.3" TFT-LCD (Transmissive Amorphous Silicon TFT) module with Back-light unit.

- | | |
|-----------------------------|---|
| (1) Part Name | TX11D01VM2APA |
| (2) Module Dimensions | 105.5(W)mm x 67.2(H)mm x 3.9(D)mm typ.
(Except FPC Area) |
| (3) Effective Display Area | 95.04(W)mm x 53.856(H)mm (Diagonal:11cm) |
| (4) Dot Pitch | 0.066mm x 3(R,G,B)(W) x 0.198(H)mm |
| (5) Resolution | 480 x 3(R,G,B)(W) x 272 (H) dots |
| (6) Color Pixel Arrangement | R,G,B Vertical Stripe |
| (7) LCD Type | Transmissive Color TFT LCD (Normally White) |
| (8) Display Type | Active Matrix |
| (9) Number of Colors | 16.7 ^M Colors (R,G,B 8 Bit Digital each) |
| (10) Backlight | Light Emitting Diode (LED) x 10 |
| (11) Weight | (56)g |
| (12) Interface | 45 pin C-MOS |
| (13) Viewing Direction | 12 O'clock (The direction it's hard to be discolored) |
| (14) Touch Panel | Resistance type. The surface is anti-glare. |

4. ABSOLUTE MAXIMUM RATINGS

4.1 ELECTRICAL ABSOLUTE MAXIMUM RATINGS OF LCD

ITEM		SYMBOL	MIN.	MAX.	UNIT	REMARKS
Power Supply for Logic		DVDD	-0.3	6.0	V	
Input Voltage		V_i	0	DVDD	V	(1)
LED	Forward Current	I_F	-	35	mA	(2)
	Pulse Forward Current	I_{FP}	-	100	mA	(3)
	Reverse Voltage	V_R	-	5	V	
Static Electricity		-	-	± 15	kV	(4) (5)

Note (1) Hsync, Vsync, CLK, R0~R7, G0~G7, B0~B7

(2)

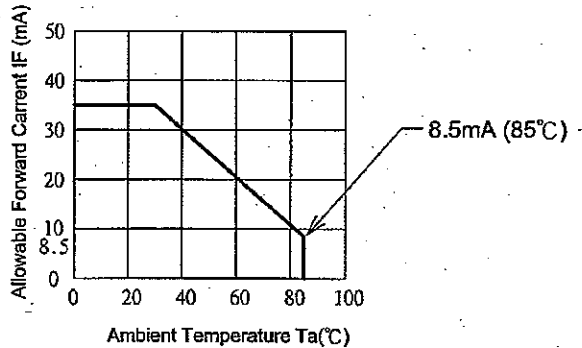

(3) IFP Conditions : pulse width ≤ 10 ms and Duty $\leq 1/10$

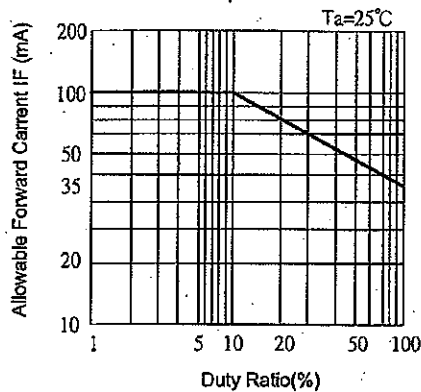

(4) Make certain you are grounded when handling LCM.

(5) Testing condition : 200pF - 0 Ω , 25° C - 70%RH.

4.2 ELECTRICAL ABSOLUTE MAXIMUM RATINGS OF TOUCH PANEL

ITEM	SPECIFICATION	UNIT	CONDITION	REMARKS
Supply Voltage	7.0	V	DC	
Endurance Voltage	25	V	DC	(Note 1)

Note 1 : Waiting 1 minute.

4.3 ENVIRONMENTAL ABSOLUTE MAXIMUM RATINGS

ITEM	OPERATING		STORAGE		REMARKS
	Min.	Max.	Min.	Max.	
Ambient Temperature	-20°C	70°C	-30°C	80°C	(Note 2,3,6,7,9,10)
Humidity	(Note 1)		(Note 1)		Without condensation
Vibration	-	(2.45)m/s ² (0.25G)	-	(11.76)m/s ² (1.2G)	(Note 4,5)
Shock	-	(29.4)m/s ² (3G)	-	(490)m/s ² (50G)	(Note 5,8)
Corrosive Gas	Not Acceptable		Not Acceptable		

Note 1 : $T_a \leq 40^\circ\text{C}$: 85%RH max.

$T_a > 40^\circ\text{C}$: Absolute humidity must be lower than the humidity of 85%RH at 40°C , as follow diagram.

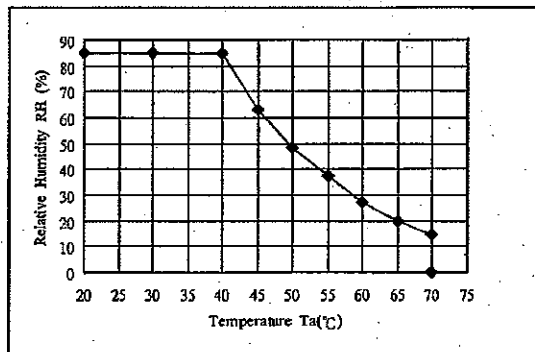

Note 2 : For storage condition T_a at $-30^\circ\text{C} < 48\text{h}$, at $80^\circ\text{C} < 100\text{h}$.

For operating condition T_a at $-20^\circ\text{C} < 100\text{h}$

Note 3 : Background color changes slightly depending on ambient temperature. This phenomenon is reversible.

Note 4 : 5Hz~100Hz(Except resonance frequency)

Note 5 : This LCM will resume normal operation after finishing the test.

Note 6 : The response time will be slower as low temperature.

Note 7 : Only operation is guaranteed at operating temperature. Contrast, response time, another display quality are evaluated at $+25^\circ\text{C}$.

Note 8 : Pulse Width : 10ms

Note 9 : This is panel surface temperature, not ambient temperature.

Note 10 : If LED is drove by high current, the life time of LED will be reduced, also high temperature and high humidity.

5. ELECTRICAL CHARACTERISTICS

5.1 ELECTRICAL CHARACTERISTICS OF LCD

Ta=25°C, VSS=0V

ITEM	SYMBOL	CONDITION	MIN.	TYP.	MAX.	UNIT
Power Supply Voltage for logic	DVDD	-	2.7	3.0	3.3	V
Input voltage for logic (note 1)	Vi	"H" level	0.7DVDD	-	DVDD	V
		"L" level	VSS	-	0.3DVDD	
Power Supply Current (note 2)	IDD	DVDD-VSS=(3.0)V	-	38	48	mA
Vsync Frequency	fV	-	56.2	60	79.2	Hz
Hsync Frequency	fH	-	16.2	17.14	22.8	KHz
DCLK Frequency	fCLK	-	8.5	9.0	12	MHz

Note 1 : CLK, R0~R7, G0~G7, B0~B7.

Note 2 : fV=60Hz, Ta=25°C, Pattern used as display pattern : All black.

5.2 ELECTRICAL CHARACTERISTICS OF BACK LIGHT

ITEM	SYMBOL	CONDITION	MIN.	TYP.	MAX.	UNIT	REMARKS
LED Input Voltage	VF	IF=20mA	-	3.2	3.5	V	LED / Part
LED Forward Current	IF	-	-	20	25	mA	LED / Part
LED Reverse Current	IR	VR=5V	-	-	50	μA	LED / Part

5.3 ELECTRICAL CHARACTERISTICS OF TOUCH PANEL

ITEM		SPECIFICATION	UNIT
Resistance between Terminal	XR - XL	430~1310	ohm
	YU - YL	160~600	ohm
Insulance Resistance (Note 1)	X - Y	10M min.	ohm
Linearity (Note 2,3)	X	1.5 max.	%
	Y	1.5 max.	%
Chattering		10 max.	ms

Note 1 : Operating Voltage 25V DC.

Note 2 : Test Condition.

(a) Y axis linearity testing method (with tip radius 0.8, polycetal pen). VXL-XR=5V , VOUT=VYU.

(b) X axis linearity method VYU-YL=5V , VOUT=VXL.

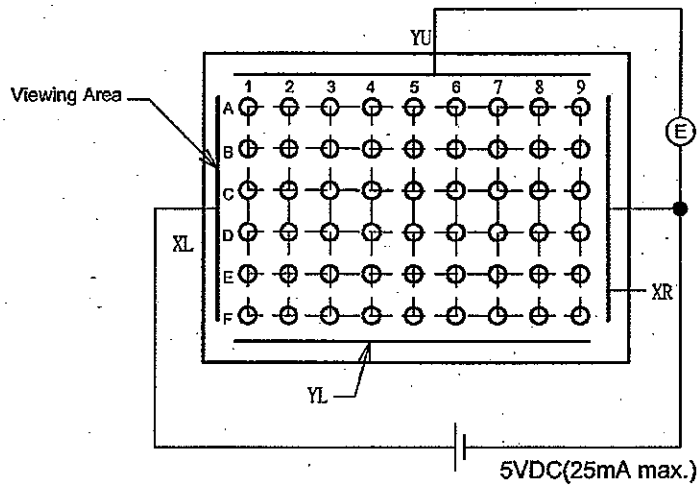

Note 3 : Calculation

(a) Y axis linearity

$$\text{Linearity} = \frac{\Delta E \text{ max.}}{EA1 - EA6} \times 100(\%)$$

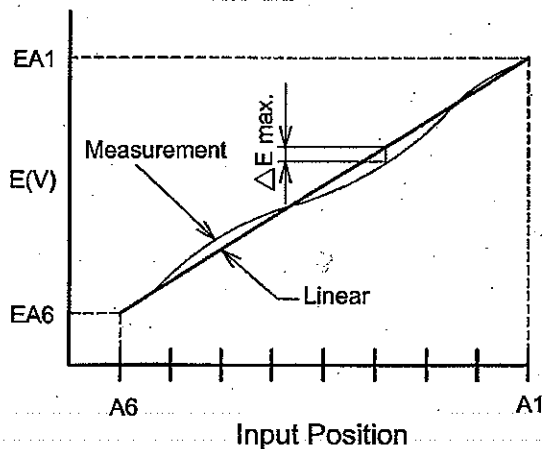

5.4 MECHANICAL CHARACTERISTICS OF TOUCH PANEL

ITEM	SPECIFICATION	UNIT	REMARKS
Pen Input Pressure	0.1 - 1.3	N	R0.8mm Polyacetal pen
Surface Hardness	3H min.	-	JIS K 5400

6. OPTICAL CHARACTERISTICS

6.1 OPTICAL CHARACTERISTICS OF LCD (BACK LIGHT ON)

Ta=25°C

ITEM	SYMBOL	CONDITION	MIN.	TYP.	MAX.	UNIT	NOTE	
Brightness	B	$\phi=0^\circ \theta=0^\circ$	300	340	-	cd/m ²	(1)	
Uniformity	-	$\phi=0^\circ \theta=0^\circ$	70	-	-	%	(2),(3),(4)	
Viewing Angle	θx	$\phi=0^\circ, K \geq 5.0$	-	70	-	deg	(5),(6)	
	$\theta x'$	$\phi=180^\circ, K \geq 5.0$	-	70	-			
	θy	$\phi=90^\circ, K \geq 5.0$	-	60	-			
	$\theta y'$	$\phi=270^\circ, K \geq 5.0$	-	80	-			
Contrast Ratio	K	$\phi=0^\circ \theta=0^\circ$	-	300	-	-	(4)	
Response Time (rise-fall)	tr+tf	$\phi=0^\circ \theta=0^\circ$	-	(30)	-	ms	(8)	
Color Tone (Primary Color)	Red	x	$\phi=0^\circ \theta=0^\circ$	0.55	0.60	0.65	-	(4)
		y		0.31	0.36	0.41	-	
	Green	x		0.33	0.38	0.43	-	
		y		0.50	0.55	0.60	-	
	Blue	x		0.10	0.15	0.20	-	
		y		0.04	0.09	0.14	-	
	White	x		0.28	0.33	0.38	-	
		y		0.28	0.33	0.38	-	

(Measurement condition : HITACHI standard)

Note 1 : Active area center

Note (4)~(7) : See page 6-2/2

Note 2 : Driving Condition

Display Pattern : White Raster

LED Current : 20mA / Part

Measurement of the following

5 places on the display.

Note 3 : Definition of the brightness uniformity

$$\left(\frac{\text{Min. brightness}}{\text{Max. brightness}} \right) \times 100$$

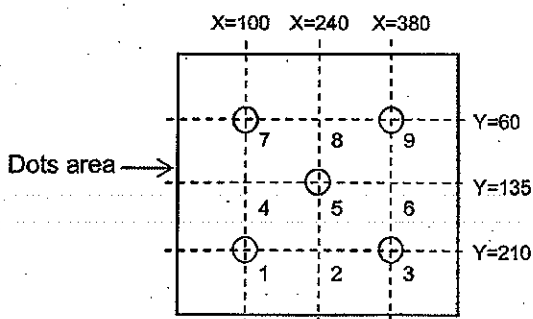

Note 4 : Measurement Condition

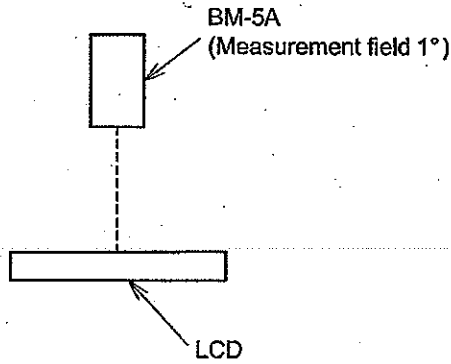

Note 5 : Definition of θ and ϕ (Normal) Viewing direction

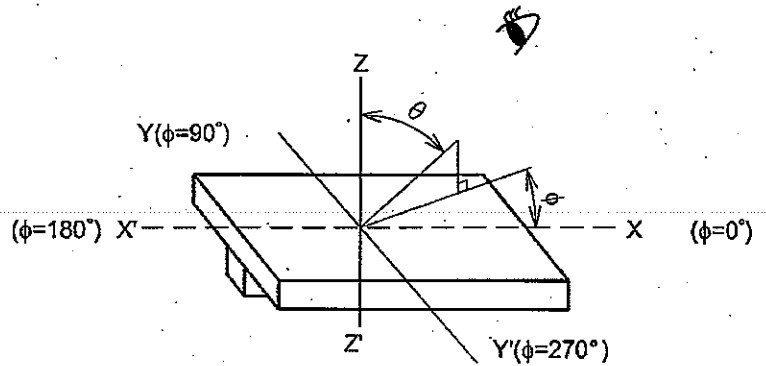

Note 6 : Definition of Viewing angle

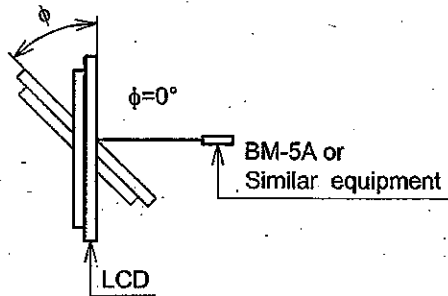

Note 7 : Definition of contrast "K"

$$K = \frac{\text{White Brightness}}{\text{Black Brightness}}$$

Note 8 : Definition optical response time

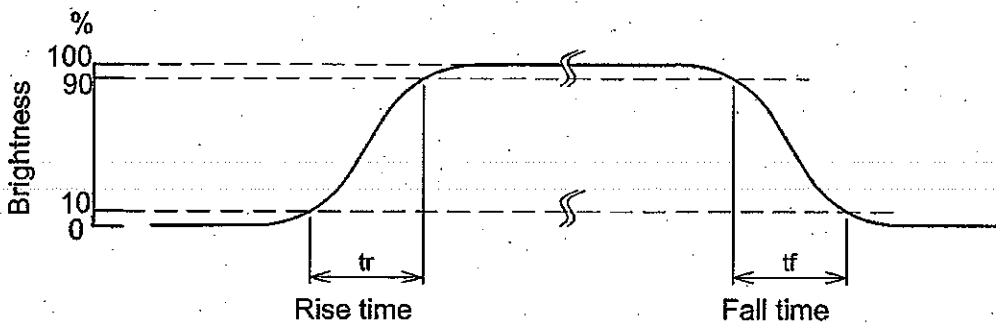
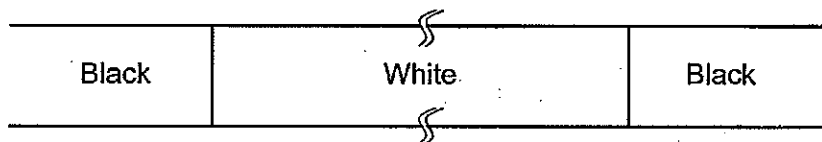

7. BLOCK DIAGRAM (FOR REFERENCE ONLY)

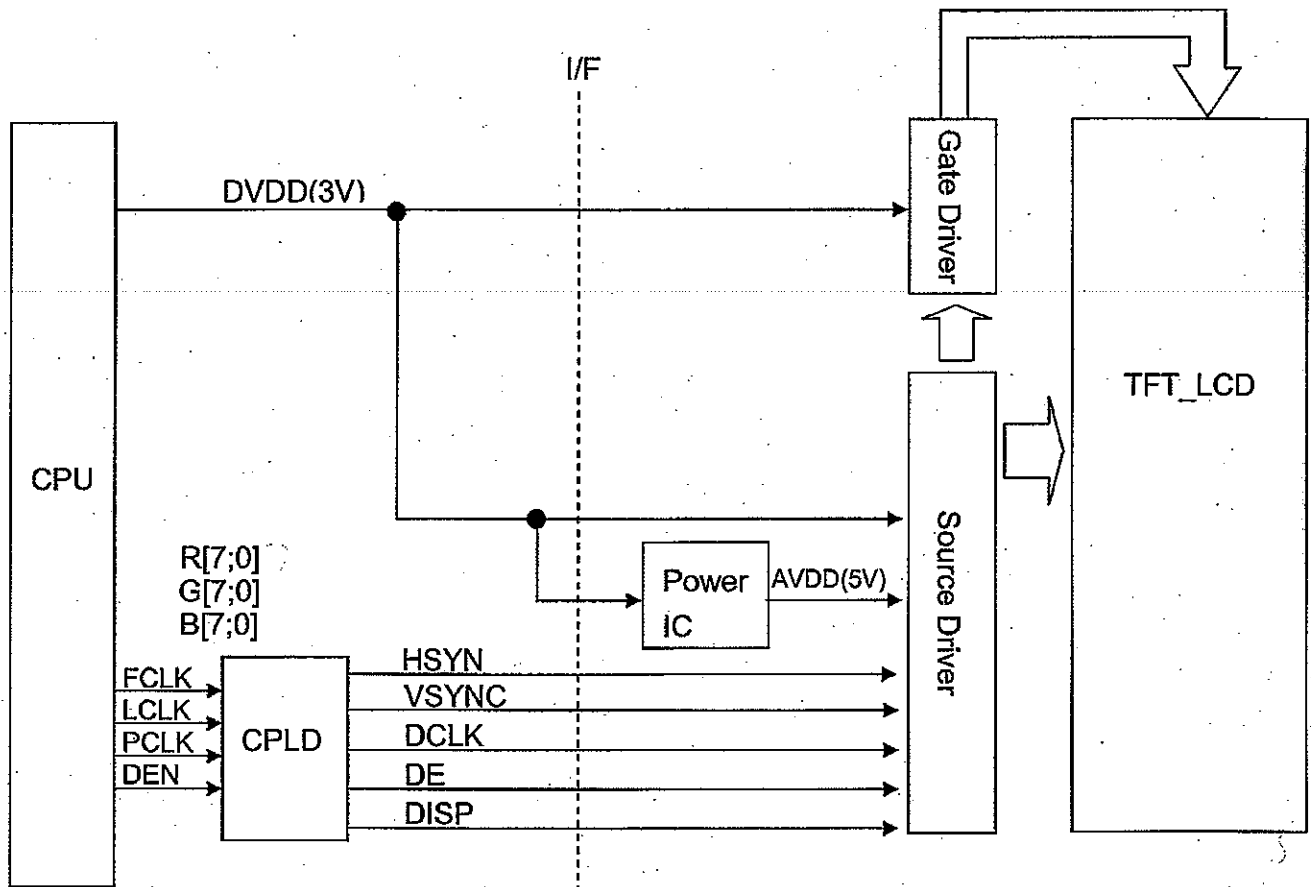

8. INTERFACE TIMING

8.1 TIMING REQUIREMENT 1

($T_a=25^\circ\text{C}$, $DVDD=2.7$ to 3.3V , $DVSS=0\text{V}$, $t_r(1)=t_f(1)=2\text{ns}$)

PARAMETER	SYMBOL	MIN.	TYP.	MAX.	UNIT
DISP setup time	t_{diss}	(10)	-	-	ns
DISP hold time	t_{dish}	(10)	-	-	ns
Clock period	$PW_{CLK(1)}$	(66.7)	-	-	ns
Clock pulse high period	$PWH(1)$	(26.7)	-	-	ns
Clock pulse low period	$PWL(1)$	(26.7)	-	-	ns
Hsync setup time	t_{hs}	(10)	-	-	ns
Hsync hold time	t_{hh}	(10)	-	-	ns
Data setup time	t_{ds}	(10)	-	-	ns
Data hold time	t_{dh}	(10)	-	-	ns
DE setup time	t_{des}	(10)	-	-	ns
DE hold time	t_{deh}	(10)	-	-	ns
Vsync setup time	t_{vhs}	(10)	-	-	ns
Vsync hold time	t_{vhh}	(10)	-	-	ns

Note(1) : t_r , t_f is defined 10% to 90% of signal amplitude.

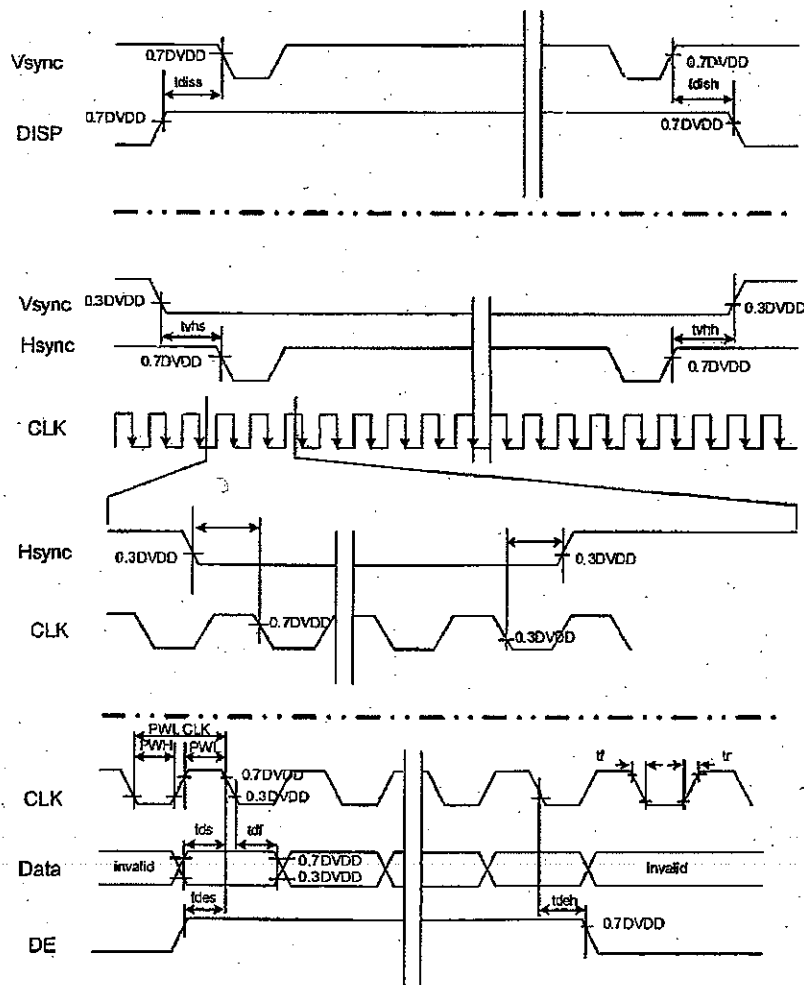

Figure 8.1 Input setup timing

8.2 TIMING REQUIREMENT 2

(480RGBx272, Ta=25°C, DVDD=2.7 to 33V, VSS=0V)

PARAMETER	SYMBOL	MIN.	TYP.	MAX.	UNIT
Clock cycle	$f_{CLK(1)}$	8.5	9	12	MHz
Hsync cycle	1/th	16.2	17.14	22.8	KHz
Vsync cycle	1/tv	56.2	60	79.2	Hz
Horizontal Signal					
Horizontal cycle	th ₍₁₎	-	525	-	CLK
Horizontal display period	thd	-	480	-	CLK
Horizontal front porch	thf	2	-	-	CLK
Horizontal pulse width	thp	2	41	-	CLK
Horizontal back porch	thb	2	2	-	CLK
Vertical Signal					
Vertical cycle	tv	-	286	-	H
Vertical display period	tvd	-	272	-	H
Vertical front porch	tvf	1	2	-	H
Vertical pulse width	tvp	1	10	-	H
Vertical back porch	tvb	1	2	-	H

Note(1): thd=480CLK, thf=2CLK, thp=41CLK, thb=2CLK, thf + thp + thb > 44CLK, (CLK=1/f_{CLK}, H=th)

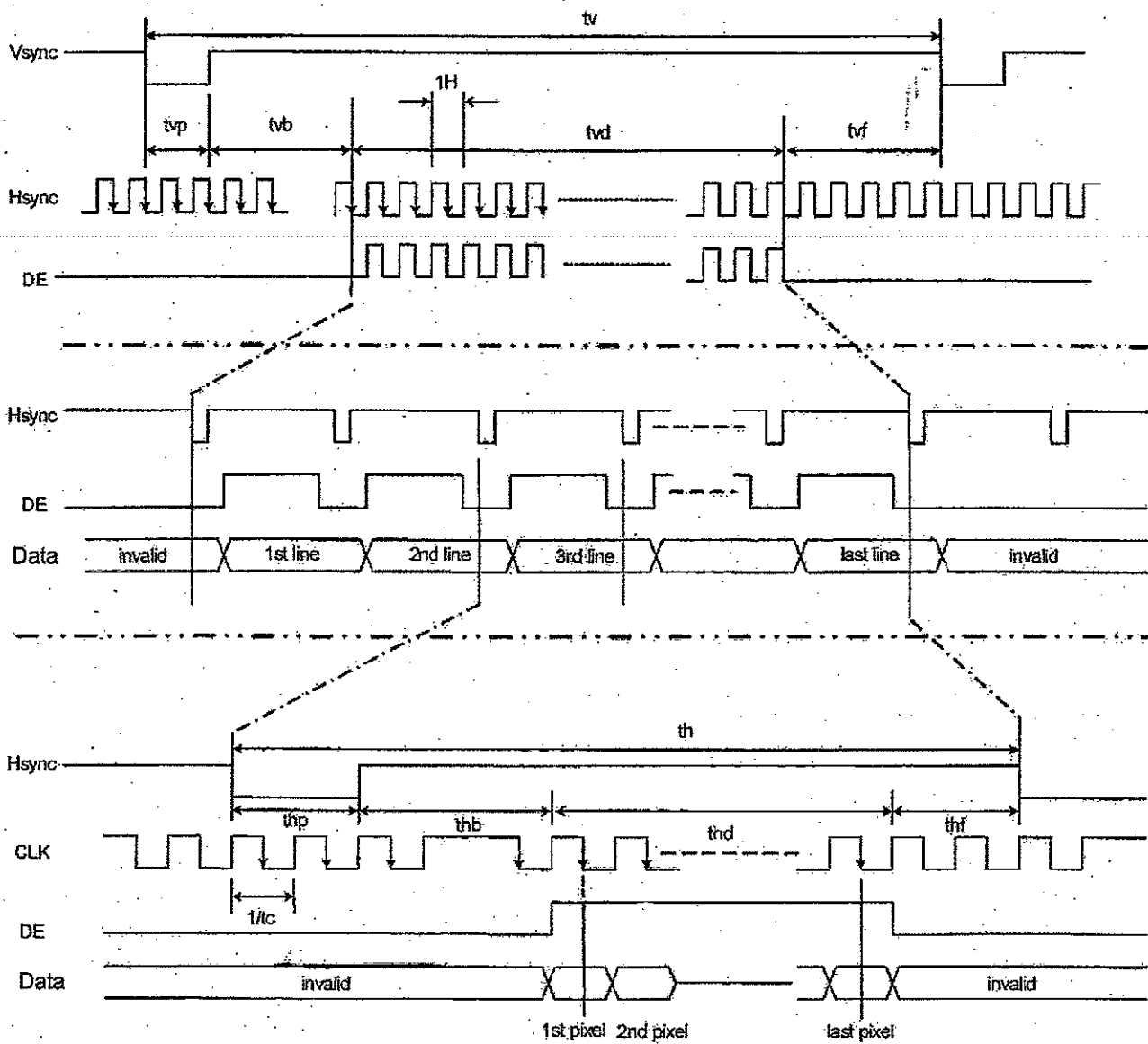
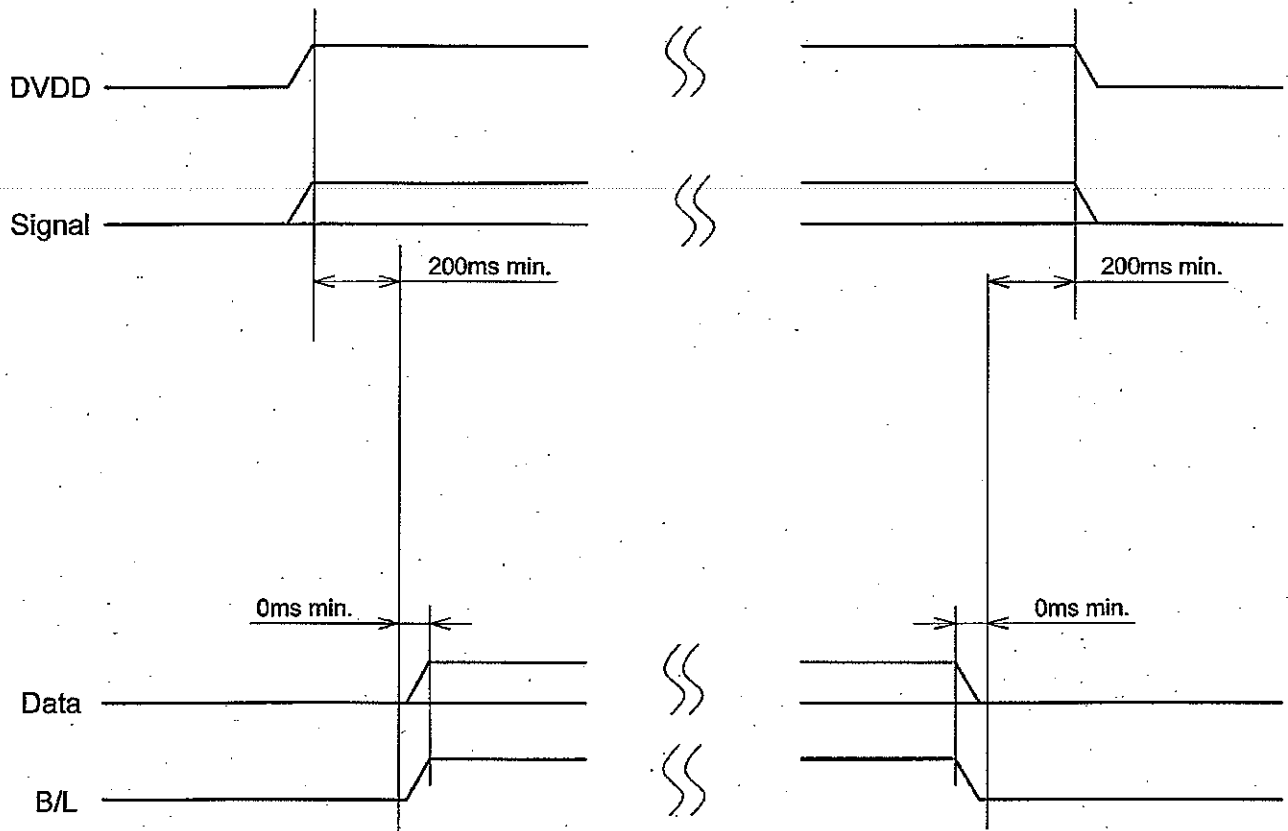

Figure 8.2 Input timing

8.3 POWER ON/OFF SEQUENCE



8.4.RELATIONSHIP BETWEEN DISPLAYED COLOR AND INPUT DATA
 8.4.1 Display Colors

Input color	Red Data								Green Data								Blue Data							
	R7	R6	R5	R4	R3	R2	R1	R0	G7	G6	G5	G4	G3	G2	G1	G0	B7	B6	B5	B4	B3	B2	B1	B0
	MSB				LSB				MSB				LSB				MSB				LSB			
Basic Color	Black	0	0	0	0	0	0	0	0	0	0	0	0	0	0	0	0	0	0	0	0	0	0	0
	Red(0)	1	1	1	1	1	1	1	1	0	0	0	0	0	0	0	0	0	0	0	0	0	0	0
	Green(0)	0	0	0	0	0	0	0	0	1	1	1	1	1	1	1	0	0	0	0	0	0	0	0
	Blue(0)	0	0	0	0	0	0	0	0	0	0	0	0	0	0	0	1	1	1	1	1	1	1	1
	Cyan	0	0	0	0	0	0	0	0	1	1	1	1	1	1	1	1	1	1	1	1	1	1	1
	Magenta	1	1	1	1	1	1	1	1	0	0	0	0	0	0	0	1	1	1	1	1	1	1	1
	Yellow	1	1	1	1	1	1	1	1	1	1	1	1	1	1	1	0	0	0	0	0	0	0	0
	White	1	1	1	1	1	1	1	1	1	1	1	1	1	1	1	1	1	1	1	1	1	1	1
Red	Black	0	0	0	0	0	0	0	0	0	0	0	0	0	0	0	0	0	0	0	0	0	0	
	Red(62)	0	0	0	0	0	0	0	1	0	0	0	0	0	0	0	0	0	0	0	0	0	0	
	Red(61)	0	0	0	0	0	0	1	0	0	0	0	0	0	0	0	0	0	0	0	0	0	0	
	:	:	:	:	:	:	:	:	:	:	:	:	:	:	:	:	:	:	:	:	:	:	:	
	:	:	:	:	:	:	:	:	:	:	:	:	:	:	:	:	:	:	:	:	:	:	:	
	Red(2)	1	1	1	1	1	1	1	1	0	0	0	0	0	0	0	0	0	0	0	0	0	0	
	Red(1)	1	1	1	1	1	1	1	0	0	0	0	0	0	0	0	0	0	0	0	0	0	0	
Red(0)	1	1	1	1	1	1	1	1	0	0	0	0	0	0	0	0	0	0	0	0	0	0		
Green	Black	0	0	0	0	0	0	0	0	0	0	0	0	0	0	0	0	0	0	0	0	0	0	
	Green(62)	0	0	0	0	0	0	0	0	0	0	0	0	0	0	1	0	0	0	0	0	0	0	
	Green(61)	0	0	0	0	0	0	0	0	0	0	0	0	0	1	0	0	0	0	0	0	0	0	
	:	:	:	:	:	:	:	:	:	:	:	:	:	:	:	:	:	:	:	:	:	:	:	
	:	:	:	:	:	:	:	:	:	:	:	:	:	:	:	:	:	:	:	:	:	:	:	
	Green(2)	0	0	0	0	0	0	0	0	1	1	1	1	1	1	1	0	0	0	0	0	0	0	
	Green(1)	0	0	0	0	0	0	0	0	1	1	1	1	1	1	0	0	0	0	0	0	0	0	
Green(0)	0	0	0	0	0	0	0	0	1	1	1	1	1	1	1	0	0	0	0	0	0	0		
Blue	Black	0	0	0	0	0	0	0	0	0	0	0	0	0	0	0	0	0	0	0	0	0	0	
	Blue(62)	0	0	0	0	0	0	0	0	0	0	0	0	0	0	0	0	0	0	0	0	0	1	
	Blue(61)	0	0	0	0	0	0	0	0	0	0	0	0	0	0	0	0	0	0	0	0	0	1	
	:	:	:	:	:	:	:	:	:	:	:	:	:	:	:	:	:	:	:	:	:	:	:	
	:	:	:	:	:	:	:	:	:	:	:	:	:	:	:	:	:	:	:	:	:	:	:	
	Blue(2)	0	0	0	0	0	0	0	0	0	0	0	0	0	0	0	1	1	1	1	1	1	1	
	Blue(1)	0	0	0	0	0	0	0	0	0	0	0	0	0	0	0	1	1	1	1	1	1	0	
Blue(0)	0	0	0	0	0	0	0	0	0	0	0	0	0	0	0	1	1	1	1	1	1	1		

8.4.2 Data address

D (0,0) D (1,0)

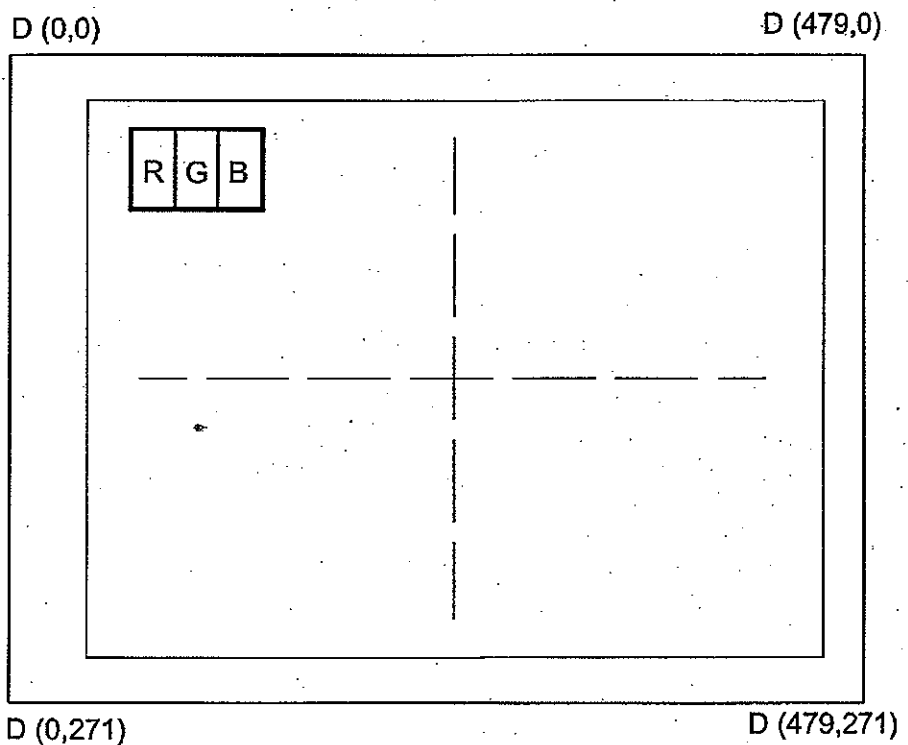
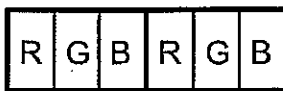

Top View

8.5 POWER SUPPLY CIRCUIT FOR LED BL (REFERENCE ONLY)

Example 1.
LED B/L

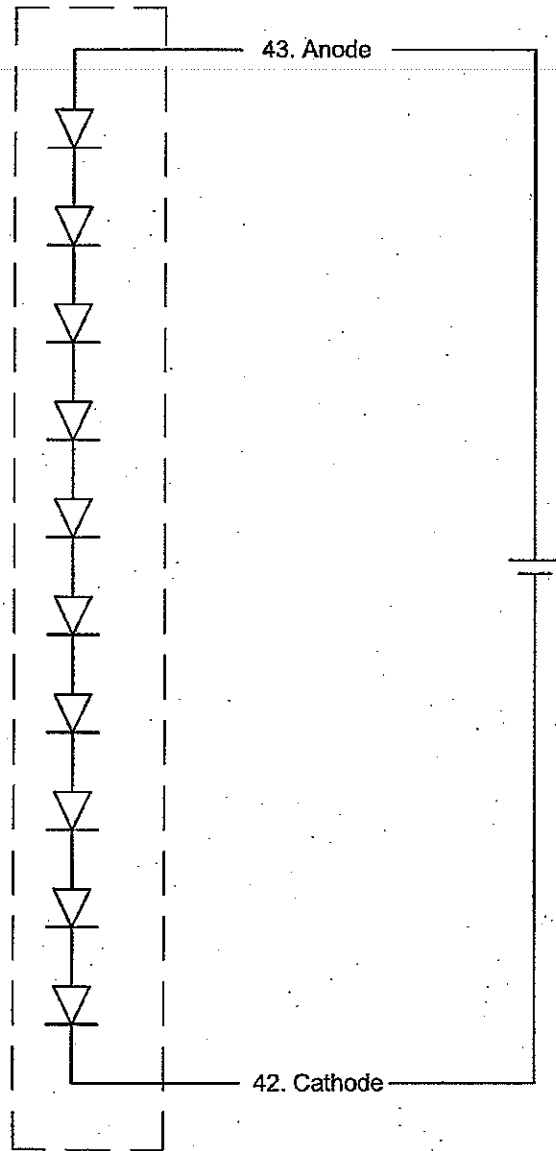

8.7 INTERNAL PIN CONNECTION

Suitable connector : FH23-45S-0.3SHW

No	SYMBOL	FUNCTION	No	SYMBOL	FUNCTION
1	VSS	Ground	24	B3	Blue Data
2	VSS	Ground	25	B4	Blue Data
3	DVDD	Power Supply for Logic	26	B5	Blue Data
4	DVDD	Power Supply for Logic	27	B6	Blue Data
5	R0	Red Data (LSB)	28	B7	Blue Data (MSB)
6	R1	Red Data	29	VSS	Ground
7	R2	Red Data	30	DCLK	Dot Clock
8	R3	Red Data	31	DISP	Display On/Off
9	R4	Red Data	32	HSYNC	Horizontal Sync Signal
10	R5	Red Data	33	VSYNC	Vertical Sync Signal
11	R6	Red Data	34	DE	Data Enable
12	R7	Red Data (MSB)	35	NC	No Connection
13	G0	Green Data (LSB)	36	VSS	Ground
14	G1	Green Data	37	YU	Touch Panel Upper Side
15	G2	Green Data	38	XL	Touch Panel Left Side
16	G3	Green Data	39	YB	Touch Panel Bottom Side
17	G4	Green Data	40	XR	Touch Panel Right Side
18	G5	Green Data	41	VSS	Ground
19	G6	Green Data	42	Cathode	LED Power Supply (-)
20	G7	Green Data (MSB)	43	Anode	LED Power Supply (+)
21	B0	Blue Data (LSB)	44	U/D	Shift Direction Control Pin (U/D) H: Top -> Bottom(Default) L: Bottom -> Top
22	B1	Blue Data	45	L/R	Shift Direction Control Pin (L/R) H: Left-> Right(Default) L: Right -> Left
23	B2	Blue Data			

9. DIMENSIONAL OUTLINE

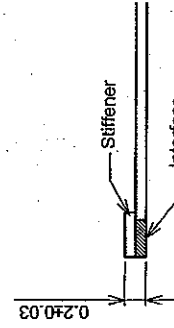
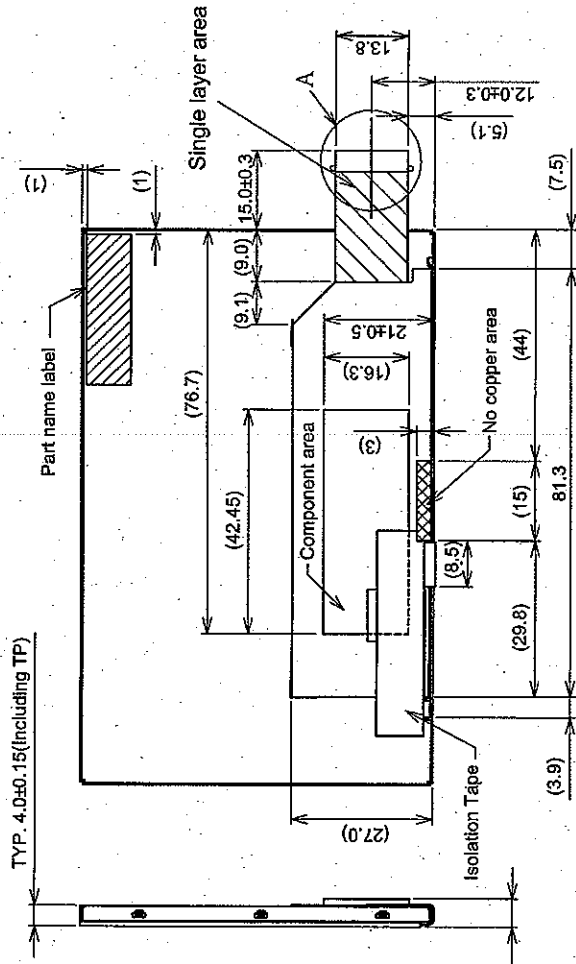
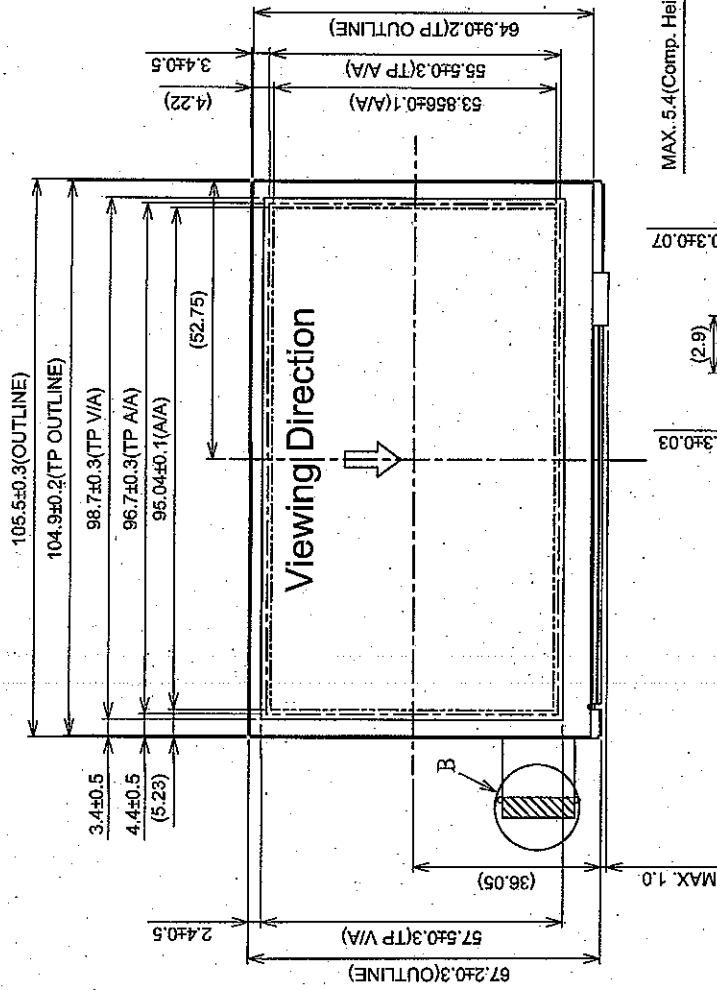

Thickness of Interface

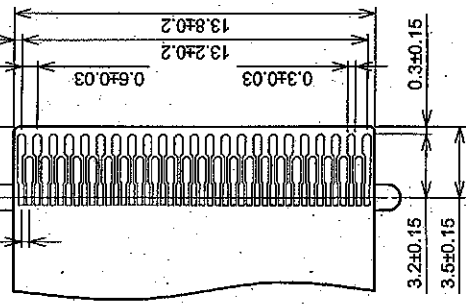

Interface Detail A

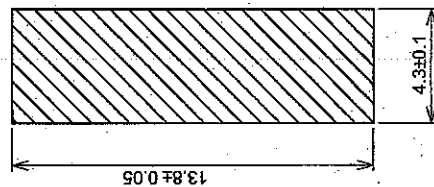

Stiffener Detail B

Scale : NTS
Unit : mm