

# TX Series "63"

## Triplex Plunger Pump, Solid Shaft

### FEATURES

- Flex coupling and bell housing available for direct drive
- Oversized bearings
- Longer life low and high pressure seals
- Forged brass manifold with exclusive lifetime warranty

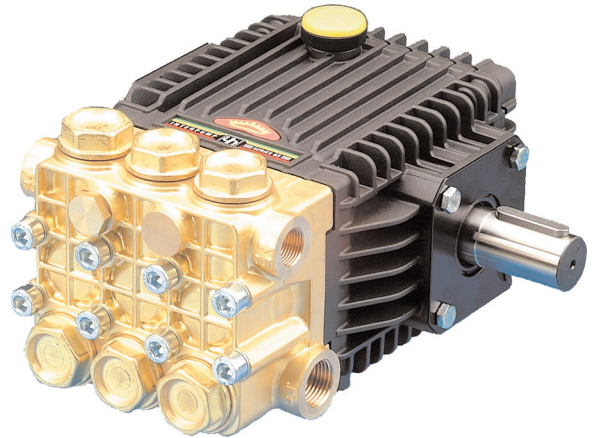

### SPECIFICATIONS

Pump Model	TX1812S17	TX1512S17	TX1508S34	TX1510S34
Maximum Volume	3.2/3.8 GPM	2.1/2.6 GPM	3.0 GPM	4.0 GPM
Max. Discharge Pressure	2000 PSI	3000 PSI		
Horsepower	4.4/5.2 EBHP	4.3/5.3 EBHP	6.2 EBHP	8.2 EBHP
Maximum Pump Speed	1450/1750 RPM		3400 RPM	
Maximum Inlet Pressure	125 PSI			
Maximum Inlet Vacuum	3 Ft. Water (2.6 in. Hg)		Flooded	
Bore	.709 in. / 18 mm	.591 in. / 15 mm		
Stroke	.472 in. / 12 mm		.315 in. / 8 mm	.394 in. / 10 mm
Crankcase Oil Capacity	14.0 oz.			
Max Fluid Temperature	165° F			
Inlet Port Thread	1/2-14 BSPP-F			
Discharge Port Thread	3/8-19 BSPP-F			
Shaft Diameter	.945 in. / 24 mm			
Weight	19 lbs.			
Dimensions	8.4 x 8.3 x 4.8 in.			

### DIMENSIONAL DRAWING

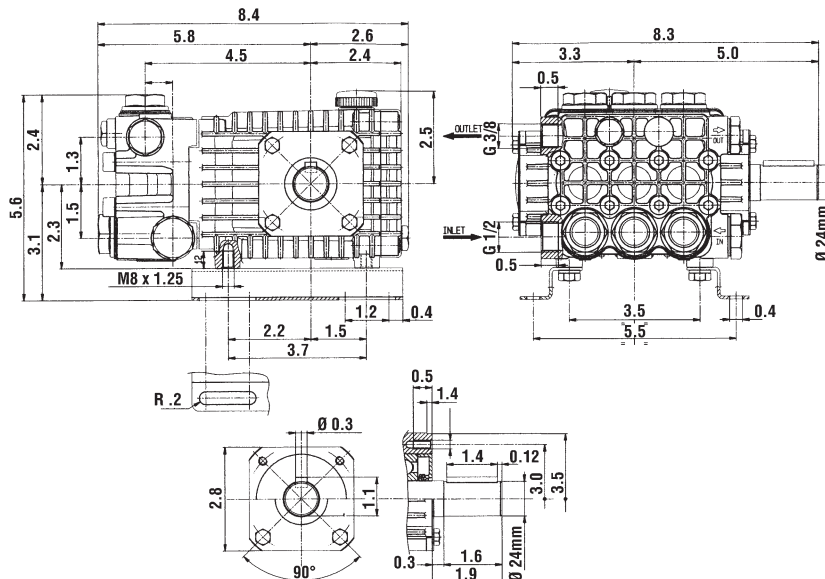

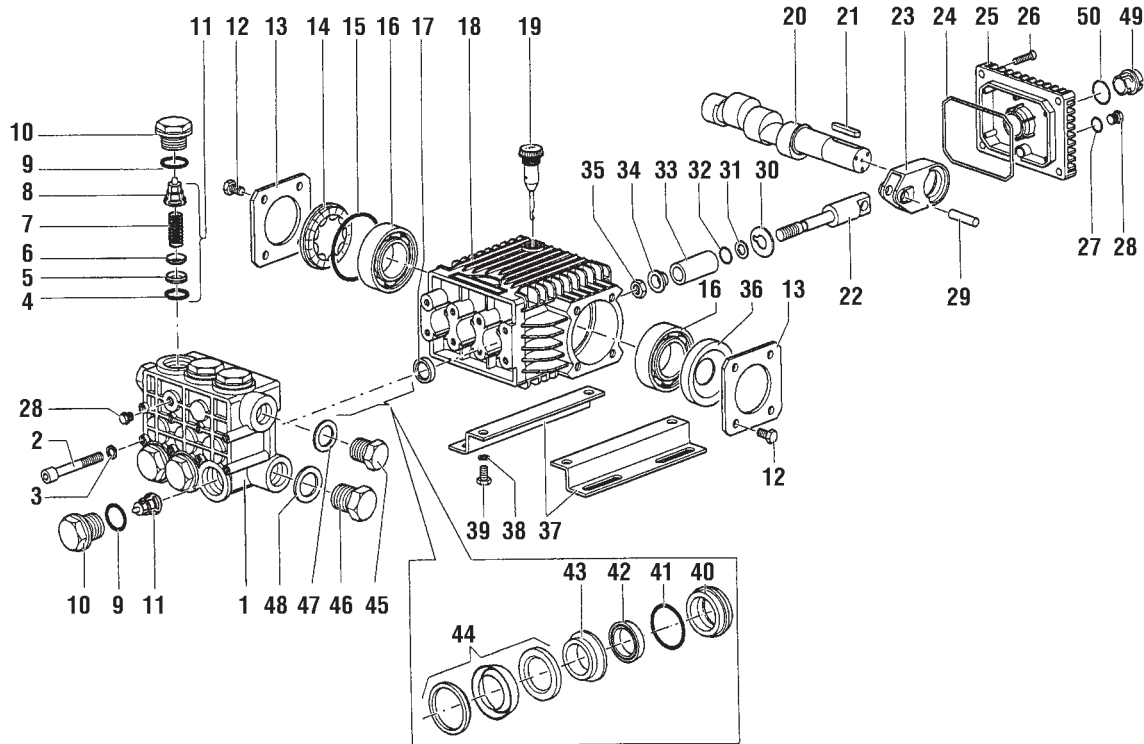

### PARTS LIST

ITEM	PART NO.	DESCRIPTION	KIT NO.	QTY.	ITEM	PART NO.	DESCRIPTION	KIT NO.	QTY.	ITEM	PART NO.	DESCRIPTION	KIT NO.	QTY.
1.	63120041	Manifold, 15 mm		1	63020865	Crankshaft, 8 mm		1	36.	90164100	Oil Seal		1	
	63120341	Manifold, 18 mm		1	63021265	Crankshaft, 10 mm		1	37.	50200074	Rail		2	
2.	99319200	Screw, M8 x 65		8	63021665	Crankshaft, 12mm		1	38.	96701600	Lockwasher, M8		4	
3.	96701400	Lockwasher, M8.4		8	21.	91489200	Key		1	39.	99303700	Screw, M8 x 16		4
4.	90384100	O-ring	123	6	22.	63050066	Plunger Guide		3	40.	63080070	Seal Retn'r, 15mm	162,166	3
5.	36200366	Valve Seat	123	6	23.	63030022	Connecting Rod		3	41.	63080170	Seal Retn'r, 18mm	163,167	3
6.	36200176	Valve Plate	123	6	24.	90392000	O-ring, Cover		1	42.	90260800	Seal, LP,15mm	160,166	3
7.	94737600	Spring	123	6	25.	63160022	Rear Crankcase Cover		1	43.	90265000	Seal, LP,18mm	161,167	3
8.	36202551	Valve Cage	123	6	26.	99183700	Screw, M6 x 14		4	44.	63216070	Int. Ring,15mm	164,166	3
9.	90384700	O-ring	124	6	27.	701013	O-ring		1	45.	63216170	Int. Ring,18mm	165,167	3
10.	98222600	Valve Cap	124	6	28.	98204100	Plug, 1/4" G		2	46.	90261200	Packing Assy,15mm	160,166	3
11.	36711501	Valve Assembly	123	6	29.	97733500	Connecting Rod Pin		3	47.	90265400	Packing Assy,18mm	161,167	3
12.	99180700	Screw, M6 x 10		8	30.	96707500	Flinger Washer		3	48.	98210000	Plug, 3/8" G		1
13.	50150074	Bearing Cover		2	31.	660024	Anti-extrusion Ring		3	49.	98217600	Plug, 1/2" G		1
14.	44211801	Oil Level Indicator		1	32.	701009	O-ring		3	47.	96738000	Washer, M17.5		1
15.	90409700	O-ring		1	33.	52040009	Ceramic Plunger, 15mm		3	48.	96751400	Washer, M21.5		1
16.	91832900	Ball Bearing		2	34.	44040109	Ceramic Plunger, 18mm		3	49.	63210051	Oil Level Indicator		1
17.	90159500	Oil Seal	159	3	35.	44211570	Bushing		3	50.	90405100	O-ring		1
18.	63010022	Crankcase		1		92221500	Nut, M8		3					
19.	98210300	Oil Dip Stick		1										

### REPAIR KITS

KIT NO.	123	124	159	160 or 161 (15mm) (18mm)	162 or 163 (15mm) (18mm)	164 or 165 (15mm) (18mm)	166 or 167 (15mm) (18mm)
ITEM NO.s INCLUDED IN KIT	4, 5, 6, 7, 8 (11)	9, 10	17	42, 44	40	43	40, 41, 42, 43, 44
NUMBER OF ASSEMBLIES IN KIT	6	6	3	3	3	3	1
NUMBER OF CYLINDERS KIT WILL SERVICE	3	3	3	3	3	3	1

### TORQUE SPECS\*

Pos.	Ft.-lbs.	N-M
2	14.7	20
10	73.7	100
12	7.3	10
26	7.3	10
28	14.7	20
35	11.0	15
39	14.7	20
45	29.4	40
46	29.4	40

\*Decrease torque by 20% if threads are lubricated.