



FOR MESSRS : _____

DATE : Oct.25th,2024

CUSTOMER'S ACCEPTANCE SPECIFICATIONS

TX31D203VM0EAC

Contents

| No. | ITEM | SHEET No. | PAGE |
|-----|----------------------------|------------------------------|------------|
| 1 | COVER | 7B64PS 2701-TX31D203VM0EAC-2 | 1-1/1 |
| 2 | RECORD OF REVISION | 7B64PS 2702-TX31D203VM0EAC-2 | 2-1/1 |
| 3 | GENERAL DATA | 7B64PS 2703-TX31D203VM0EAC-2 | 3-1/1 |
| 4 | ABSOLUTE MAXIMUM RATINGS | 7B64PS 2704-TX31D203VM0EAC-2 | 4-1/1 |
| 5 | ELECTRICAL CHARACTERISTICS | 7B64PS 2705-TX31D203VM0EAC-2 | 5-1/2~2/2 |
| 6 | OPTICAL CHARACTERISTICS | 7B64PS 2706-TX31D203VM0EAC-2 | 6-1/2~2/2 |
| 7 | BLOCK DIAGRAM | 7B64PS 2707-TX31D203VM0EAC-2 | 7-1/1 |
| 8 | RELIABILITY TESTS | 7B64PS 2708-TX31D203VM0EAC-2 | 8-1/1 |
| 9 | LCD INTERFACE | 7B64PS 2709-TX31D203VM0EAC-2 | 9-1/7~7/7 |
| 10 | OUTLINE DIMENSIONS | 7B64PS 2710-TX31D203VM0EAC-2 | 10-1/2~2/2 |
| 11 | APPEARANCE STANDARD | 7B64PS 2711-TX31D203VM0EAC-2 | 11-1/3~3/3 |
| 12 | PRECAUTIONS | 7B64PS 2712-TX31D203VM0EAC-2 | 12-1/2~2/2 |
| 13 | DESIGNATION OF LOT MARK | 7B64PS 2713-TX31D203VM0EAC-2 | 13-1/1 |

ACCEPTED BY : _____

PROPOSED BY : Alex Lee

2. RECORD OF REVISION

| DATE | SHEET No. | SUMMARY |
|------------|---|--|
| Oct.25,'24 | 7B64PS 2708 – TX31D203VM0EAC-2 Page 8-1/1 | 8. RELIABILITY TESTS Test hour corrected: 240 hrs → 500 hrs |
| | | |

3. GENERAL DATA

3.1 DISPLAY FEATURES

This module is a 12.3" HD of 8:3 format LTPS TFT. The pixel format is vertical stripe and sub pixels are arranged as R(red), G(green), B(blue) sequentially. This display is RoHS compliant, and COG (chip on glass) technology and LED backlight are applied on this display.

| | |
|-------------------------|---|
| Part Name | TX31D203VM0EAC |
| Module Dimensions | 308.5(W) mm x 130.2(H) mm x 12.34(D) mm |
| LCD Active Area | 292.032(W) mm x 109.512(H) mm |
| Pixel Pitch | 0.1521(W) mm x 0.1521(H) mm |
| Resolution | 1920 x 3(RGB)(W) x 720(H) dots |
| Color Pixel Arrangement | R, G, B Vertical stripe |
| LCD Type | IPS, Normally Black, transmissive type |
| Display Type | Active Matrix |
| Number of Colors | 16.7M Colors (8-bit RGB) |
| Backlight | Light Emitting Diode (LED) |
| Weight | 580g |
| Interface | LVDS; 20 pins |
| Power Supply Voltage | 3.3V for LCD ; 30V for Backlight |
| Viewing Direction | Super Wide Version (In Plane Switching) |

4. ABSOLUTE MAXIMUM RATINGS

| Item | Symbol | Min. | Max. | Unit | Remarks |
|-------------------------|-----------------|------|----------------------|------|---------|
| Supply Voltage | V _{DD} | -0.3 | 4.0 | V | - |
| Input Voltage of Logic | V _I | -0.3 | V _{DD} +0.3 | V | Note 1 |
| Operating Temperature | T _{op} | -40 | 85 | °C | Note 2 |
| Storage Temperature | T _{st} | -40 | 90 | °C | Note 2 |
| Backlight Input Current | I _{LA} | 0 | 120 | mA | Note 2 |

Note 1: The rating is defined for the signal voltages of the interface such as CLK and pixel data pairs.

Note 2: The maximum rating is defined as above based on the chamber temperature, which might be different from ambient temperature after assembling the panel into the application. Moreover, some temperature-related phenomenon as below needed to be noticed:

- Background color, contrast and response time would be different in temperatures other than 25 °C.
- Operating under high temperature will shorten LED lifetime.

5. ELECTRICAL CHARACTERISTICS

5.1 OPERATING CONDITIONS

$T_a = 25\text{ }^\circ\text{C}$, $V_{SS} = 0\text{V}$

| Item | Symbol | Condition | Standard Value | | | Unit | Remarks |
|---|-------------|-----------------------|----------------|------|----------|-------------|---------|
| | | | Min. | Typ. | Max. | | |
| Power supply voltage | V_{DD} | - | 3.0 | 3.3 | 3.6 | V | - |
| Power supply current | I_{DD} | Note 1 | - | 220 | 270 | mA | Note 1 |
| Input signal voltage (CMOS) | V_{IH1} | - | $0.8V_{DD}$ | - | V_{DD} | V | - |
| | V_{IL1} | - | V_{SS} | - | 0.5V | V | - |
| Allowable Ripple Voltage | VRP | - | - | - | 100 | mV (p-p) | - |
| Differential Input High Threshold | V_{TH} | $V_{ICM}=1.2\text{V}$ | - | - | 100 | mV | Note 2 |
| Differential Input Low Threshold | V_{TL} | $V_{ICM}=1.2\text{V}$ | -100 | - | - | mV | Note 2 |
| Input Differential Voltage | $ V_{ID} $ | - | 100 | - | 600 | mV | Note 2 |
| Differential Input Common Mode Voltage | V_{ICM} | - | 1.125 | 1.2 | 1.375 | V | Note 2 |
| Frame Frequency | f_{Frame} | - | 50 | 60 | - | Hz | - |
| CLK Frequency | f_{CLK} | - | 80 | 100 | 120 | MHz | - |

Note 1: Measurement picture: White Pattern.

Power supply voltage: Typ. voltage.

Note 2:

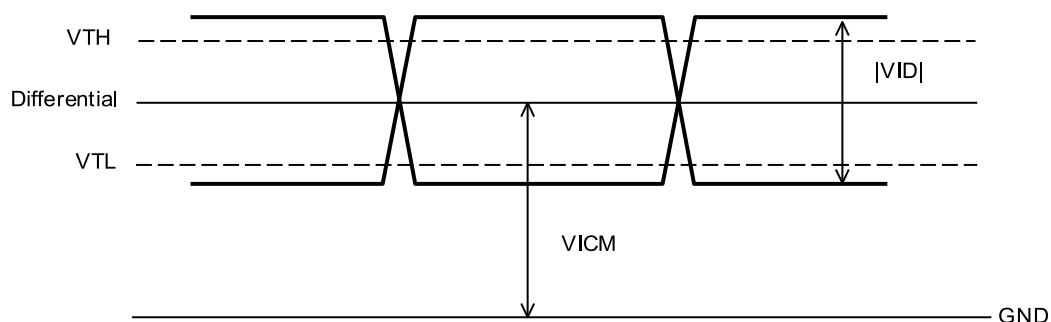

5.2 BACKLIGHT CHARACTERISTICS

$T_a = 25^\circ\text{C}$

| Item | Symbol | Condition | Min. | Typ. | Max. | Unit | Remarks |
|---------------------|----------|-------------------------|------|------|------|------|---------|
| LED Input Voltage | V_{LA} | $I_{LA}=95\text{mA}$ | - | (30) | - | V | Note 1 |
| LED Forward Current | I_{LA} | $V_{LA} = (30\text{V})$ | - | 95 | - | mA | Note 2 |
| LED Lifetime | - | $I_{LA}=95\text{mA}$ | - | 50K | - | hrs | Note 3 |

Note 1: Fig. 5.1 shows the LED backlight circuit.

Note 2: The estimated lifetime is specified as the time to reduce 50% brightness by applying 95mA at 25°C .

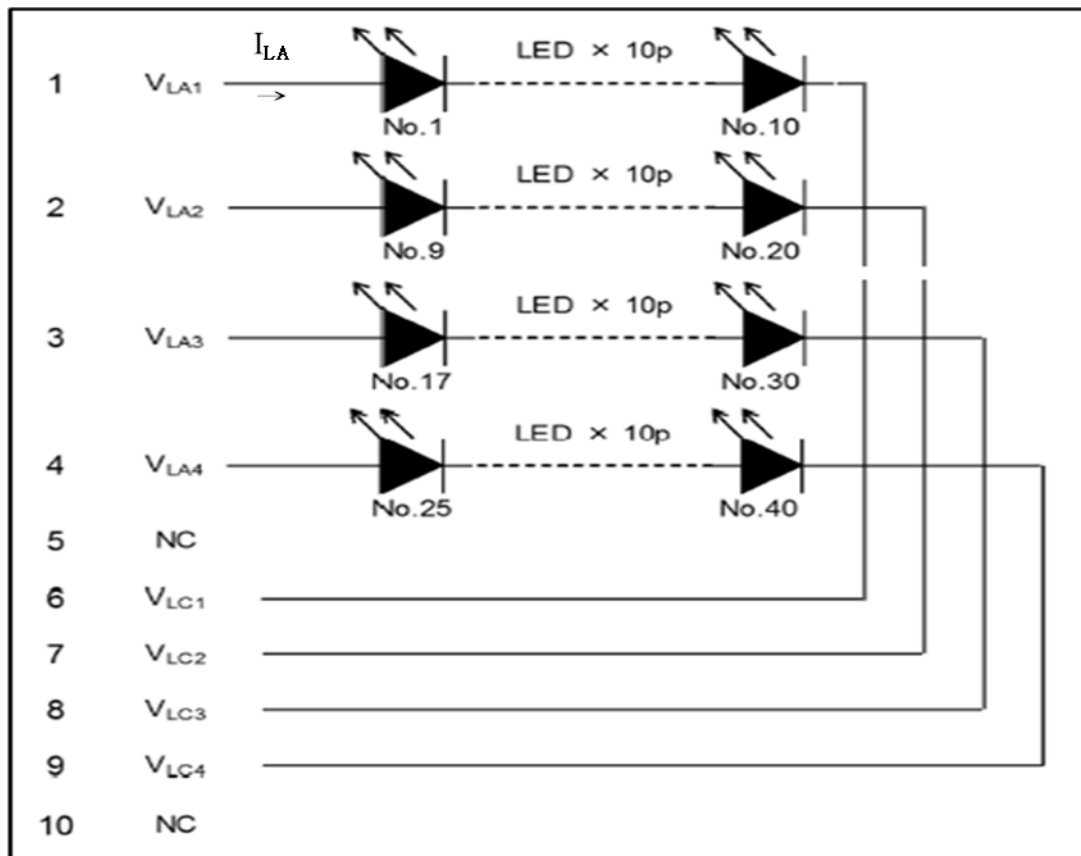

Fig 5.1

6. OPTICAL CHARACTERISTICS

The optical characteristics are measured based on the conditions as below:

- Supplying the signals and voltages defined in the section of electrical characteristics.
- The backlight unit needs to be turned on for 30 minutes.
- The ambient temperature is 25 °C .
- In the dark room less than 100 lx, the equipment has been set for the measurements as shown in Fig 6.1.

$$T_a = 25 \text{ }^\circ\text{C}, f_{Frame} = 60 \text{ Hz}, V_{DD} = 3.3\text{V}$$

| Item | Symbol | Condition | Min. | Typ. | Max. | Unit | Remarks | |
|-----------------------|---------------|---|------------------------------------|------|------|-------------------|---------|--------|
| Brightness of White | - | $\phi = 0^\circ, \theta = 0^\circ,$ $I_{LA} = 95\text{mA}$ | 1200 | 1500 | - | cd/m ² | Note 1 | |
| Brightness Uniformity | - | | 75 | - | - | % | Note 2 | |
| Contrast Ratio | CR | | 800 | 1300 | - | - | Note 3 | |
| Response Time | - | $\phi = 0^\circ, \theta = 0^\circ$ | - | - | 25 | ms | - | |
| NTSC Ratio | - | $\phi = 0^\circ, \theta = 0^\circ$ | - | 70 | - | % | - | |
| Viewing Angle | θ_x | $\phi = 0^\circ, CR \geq 10$ | - | 85 | - | Degree | Note 5 | |
| | $\theta_{x'}$ | $\phi = 180^\circ, CR \geq 10$ | - | 85 | - | | | |
| | θ_y | $\phi = 90^\circ, CR \geq 10$ | - | 85 | - | | | |
| | $\theta_{y'}$ | $\phi = 270^\circ, CR \geq 10$ | - | 85 | - | | | |
| Color Chromaticity | Red | X | $\phi = 0^\circ, \theta = 0^\circ$ | 0.59 | 0.64 | 0.69 | - | Note 6 |
| | | Y | | 0.28 | 0.33 | 0.38 | | |
| | Green | X | | 0.24 | 0.29 | 0.34 | | |
| | | Y | | 0.56 | 0.61 | 0.66 | | |
| | Blue | X | | 0.10 | 0.15 | 0.20 | | |
| | | Y | | 0.01 | 0.06 | 0.11 | | |
| | White | X | | 0.25 | 0.30 | 0.35 | | |
| | | Y | | 0.26 | 0.31 | 0.36 | | |

Note 1: The brightness is measured from the panel center point, P5 in Fig. 6.2, for the typical value.

Note 2: The brightness uniformity is calculated by the equation as below:

$$\text{Brightness uniformity} = \frac{\text{Min. Brightness}}{\text{Max. Brightness}} \times 100\%$$

which is based on the brightness values of the 9 points in active area measured by BM-5 as shown in Fig. 6.2.

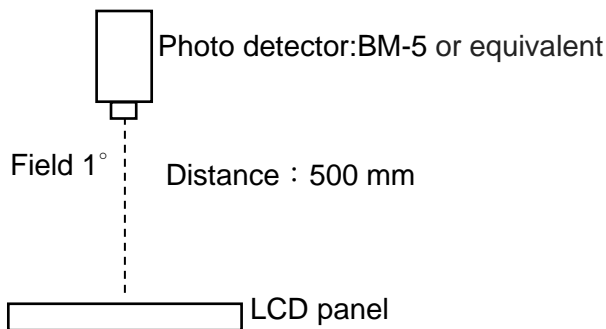

Fig 6.1

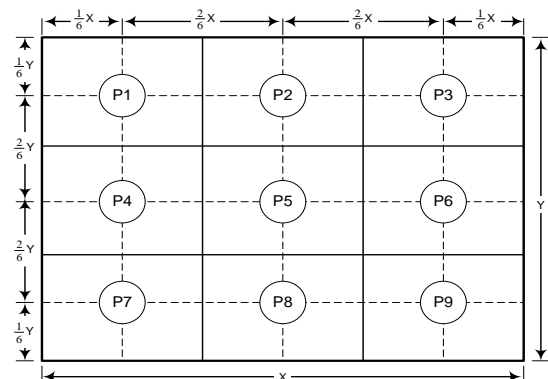

Fig 6.2

Note 3: The Contrast Ratio is measured from the center point of the panel, P5, and defined as the following equation:

$$CR = \frac{\text{Brightness of White}}{\text{Brightness of Black}}$$

Note 4: The definition of response time is shown in Fig. 6.3. The rising time is the period from 10% brightness to 90% brightness when the data is from black to white. Oppositely, Falling time is the period from 90% brightness falling to 10% brightness.

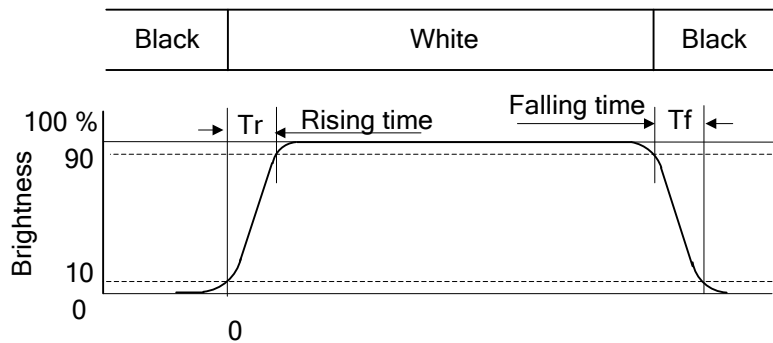

Fig 6.3

Note 5: The definition of viewing angle is shown in Fig. 6.4. Angle ϕ is used to represent viewing directions, for instance, $\phi = 270^\circ$ means 6 o'clock, and $\phi = 0^\circ$ means 3 o'clock. Moreover, angle θ is used to represent viewing angles from axis Z toward plane XY.

The display is super wide viewing angle version; 85° viewing angle can be obtained from each viewing direction.

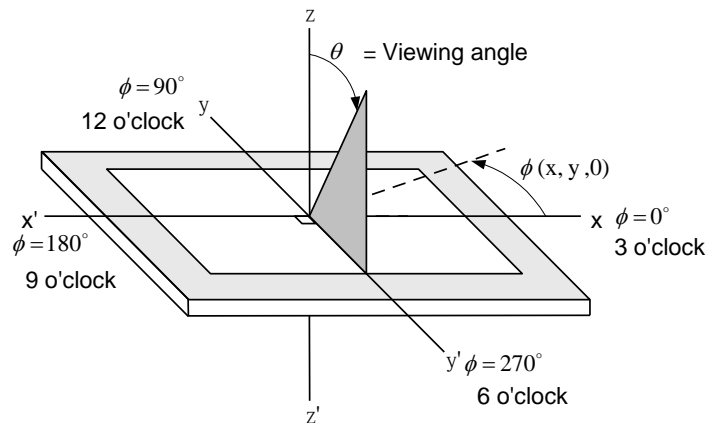
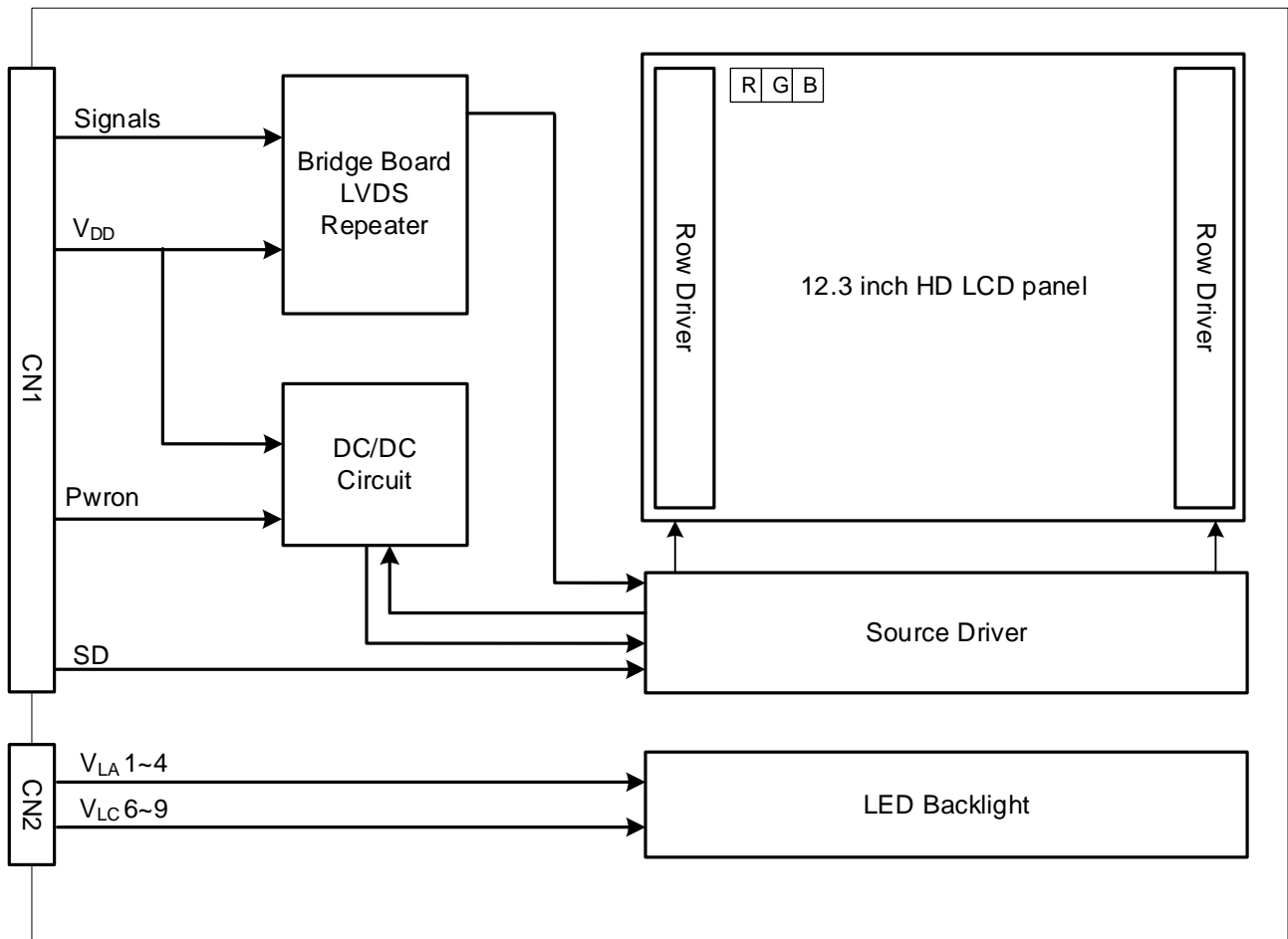

Fig 6.4

Note 6: The color chromaticity is measured from the center point of the panel, P5, as shown in Fig. 6.2.

7. BLOCK DIAGRAM



8. RELIABILITY TESTS

| Test Item | Condition | |
|-----------------------------|---|---|
| High Temperature | 1) Operating 2) 85 °C | 500 hrs |
| Low Temperature | 1) Operating 2) -40 °C | 500 hrs |
| High Temperature | 1) Storage 2) 90 °C | 500 hrs |
| Low Temperature | 1) Storage 2) -40 °C | 500 hrs |
| Heat Cycle | 1) Operating 2) -40 °C ~85 °C 3) 3hrs~1hr~3hrs | 500 hrs |
| Thermal Shock | 1) Non-Operating 2) -40 °C ↔ 85 °C 3) 0.5 hr ↔ 0.5 hr | 500 hrs |
| High Temperature & Humidity | 1) Operating 2) 65 °C & 85%RH 3) Without condensation | 500 hrs (Note 3) |
| Vibration | 1) Non-Operating 2) 10~200 Hz 3) 5G 4) X, Y, and Z directions | 1 hr for each direction |
| Mechanical Shock | 1) Non-Operating 2) 10 ms 3) 80G 4) ±X, ±Y and ±Z directions | Once for each direction |
| ESD | 1) Operating 2) Tip: 150 pF, 330 Ω 3) Air discharge for glass: ± 12KV 4) Contact discharge for metal frame: ± 15KV | 1) Glass: 9 points 2) Metal frame: 8 points (Note4) |

Note 1: Display functionalities are inspected under the conditions defined in the specification after the reliability tests.

Note 2: The display is not guaranteed for use in corrosive gas environments.

Note 3: Under the condition of high temperature & humidity, if the temperature is higher than 65 °C, the humidity needs to be reduced as Fig. 8.1 shown.

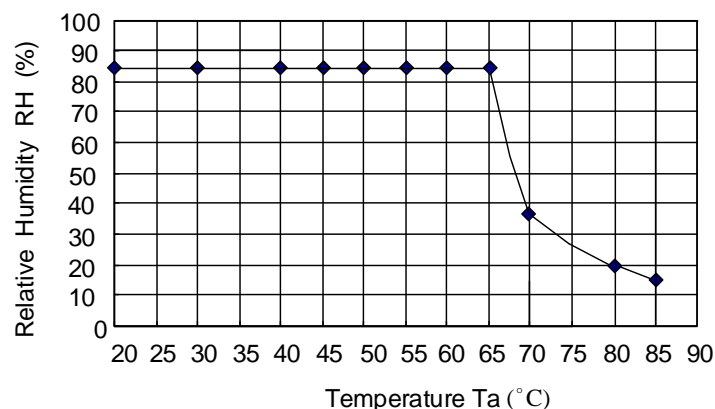

Fig. 8.1

Note 4: All pins of LCD interface (CN1) have been tested by ± 100V contact discharge of ESD under non-operating condition.

9. LCD INTERFACE

9.1 INTERFACE PIN CONNECTIONS

The display interface connector is FI-SEB20P-HF13E made by JAE or equivalent.

The pin assignment of LCD interface CN1 is as below.

| Pin No. | Symbol | Signal | Pin No. | Symbol | Signal |
|---------|-----------------|------------------------|---------|-----------------|---------------------------------|
| 1 | V _{DD} | Power Supply for Logic | 11 | IN2- | B4~B7, DE |
| 2 | V _{DD} | Power Supply for Logic | 12 | IN2+ | |
| 3 | V _{SS} | GND | 13 | V _{SS} | GND |
| 4 | V _{SS} | GND | 14 | CLK IN- | Pixel Clock |
| 5 | IN0- | R2~R7, G2 | 15 | CLK IN+ | |
| 6 | IN0+ | | 16 | V _{SS} | GND |
| 7 | V _{SS} | GND | 17 | IN3- | R0~R1, G0~G1, B0~B1 |
| 8 | IN1- | G3~G7, B2~B3 | 18 | IN3+ | |
| 9 | IN1+ | | 19 | NC | No Connect |
| 10 | V _{SS} | GND | 20 | SD | Scan Direction Control (Note 1) |

Note 1: Scan direction is available to be switched as below.

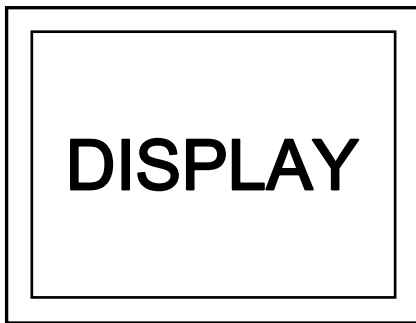

SD : Low or Open (Default)



SD : High

Note 2: IN_n- and IN_n+ (n=0,1,2,3), CLK IN- and CLK IN+ should be wired by twist-pairs or side-by-side FPC patterns, respectively.

The backlight interface (CN2) is SM10B-SRSS-TB(LF)(SN) made by JST or equivalent.

The pin assignment is as below:

| Pin No. | Symbol | Signal | Pin No. | Symbol | Signal |
|---------|--------|---------------------|---------|--------|-----------------------|
| 1 | VLA1 | LED Anode Terminal1 | 6 | VLC1 | LED Cathode Terminal1 |
| 2 | VLA2 | LED Anode Terminal2 | 7 | VLC2 | LED Cathode Terminal2 |
| 3 | VLA3 | LED Anode Terminal3 | 8 | VLC3 | LED Cathode Terminal3 |
| 4 | VLA4 | LED Anode Terminal4 | 9 | VLC4 | LED Cathode Terminal4 |
| 5 | NC | Non-Connection | 10 | NC | Non-Connection |

9.2 LVDS INTERFACE

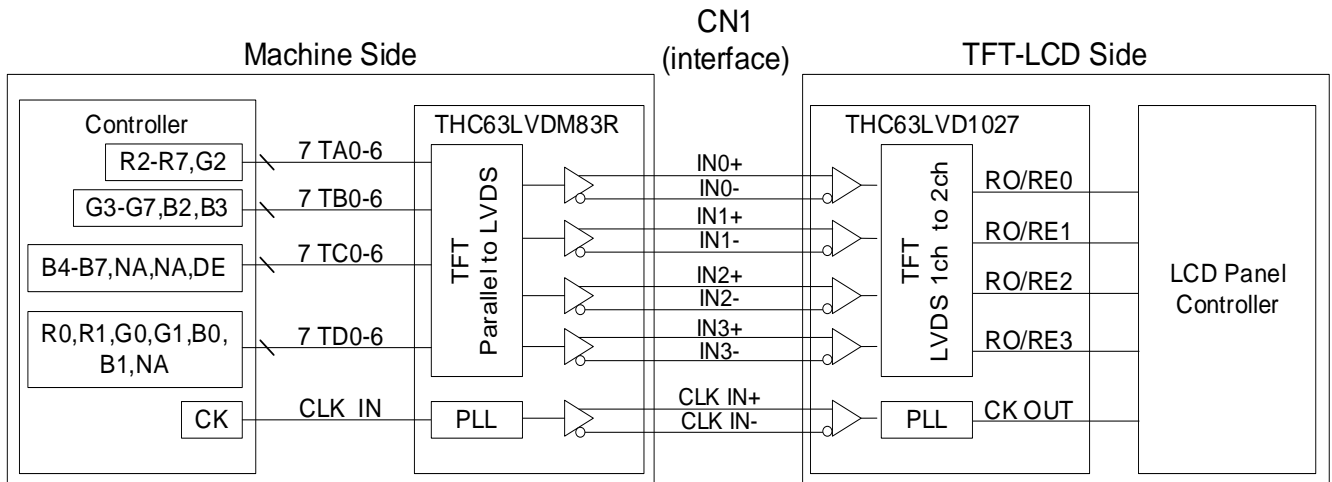

Note 1: LVDS cable impedance should be 100 ohms per signal line when each 2-lines (+, -) is used in differential mode.

Note 2: The recommended transmitter, TH63LVDM83R, is made by Thine or equivalent, which is not contained in the module.

9.3 LVDS DATA FORMAT

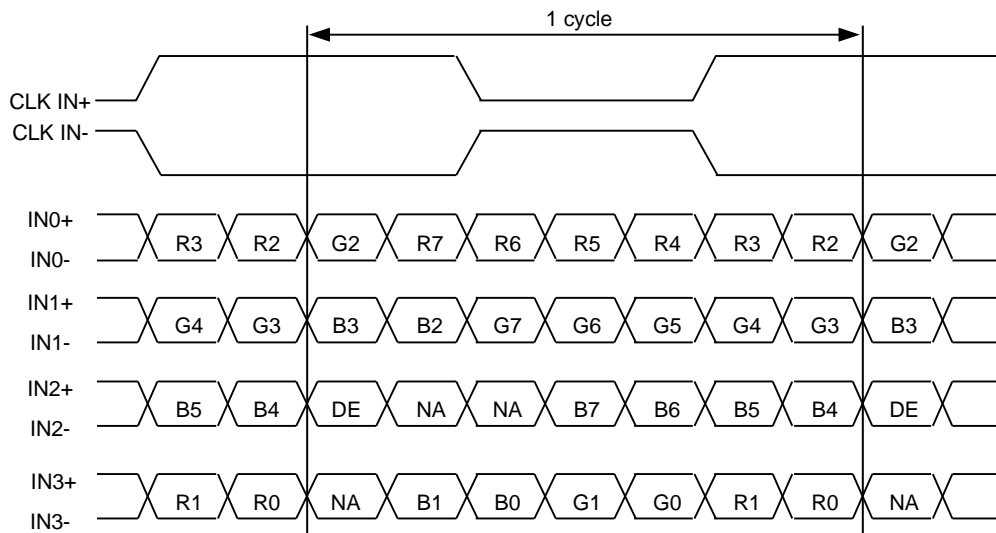

DE: Display Enable

NA: Not Available

9.4 TIMING CHART

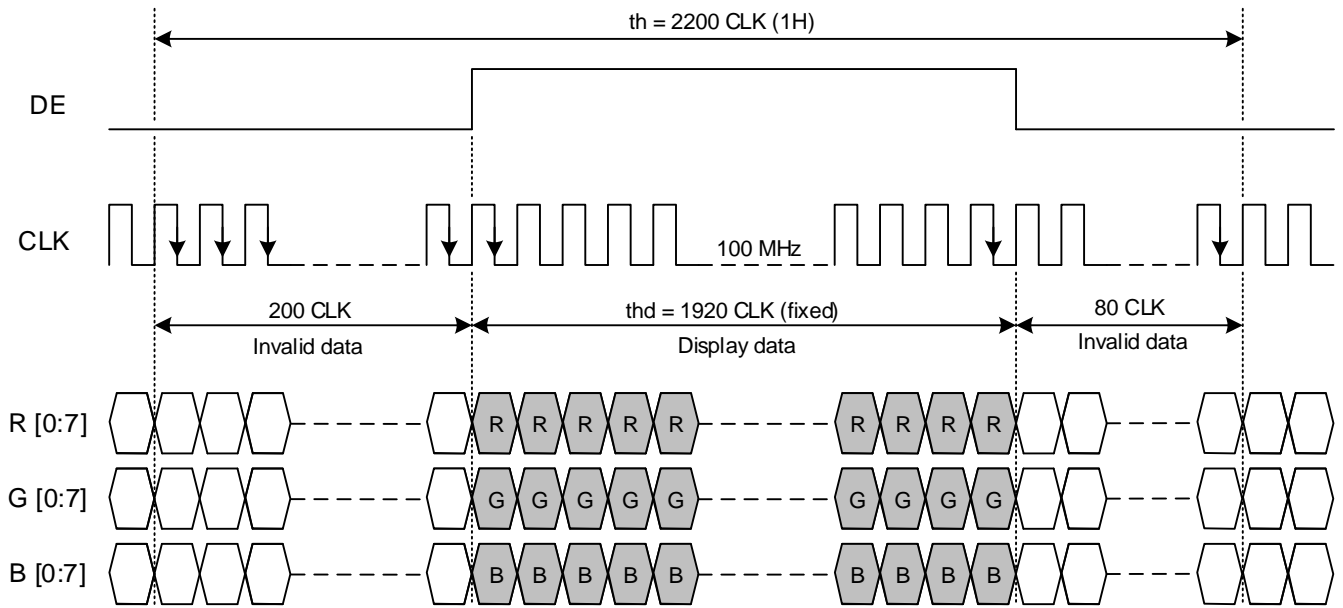

Fig. 9.1 Horizontal Timing

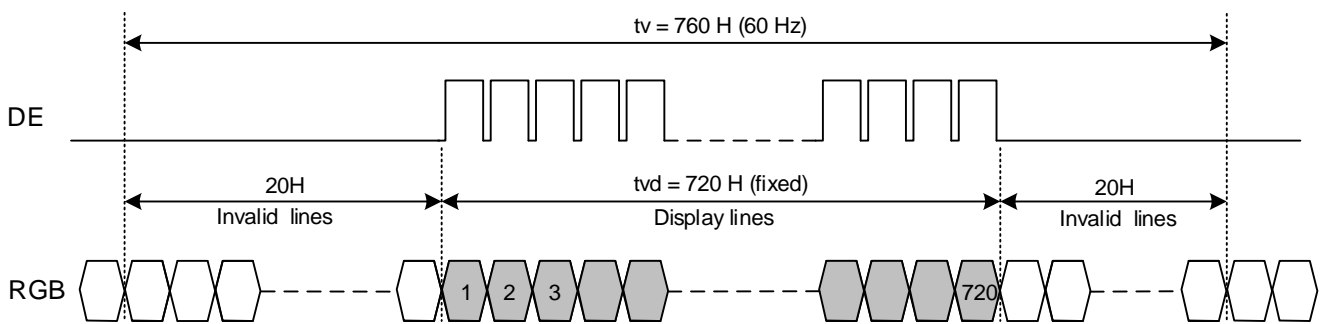

Fig. 9.2 Vertical Timing

9.5 TIME TABLE

The column of timing sets including minimum, typical, and maximum as below are based on the best optical performance, frame frequency (f_{Frame}) = 60 Hz to define.

A. Horizontal and Vertical Timing

| | Item | Symbol | Min. | Typ. | Max. | Unit |
|------------|---------------|--------|------|------|------|------|
| Horizontal | CLK Frequency | fclk | 96 | 100 | 120 | M Hz |
| | Display Data | thd | 1920 | | | CLK |
| | Cycle Time | th | 2130 | 2200 | 2520 | |
| Vertical | Display Data | tvd | 720 | | | H |
| | Cycle Time | tv | 750 | 760 | 800 | |

9.6 LVDS RECEIVER TIMING

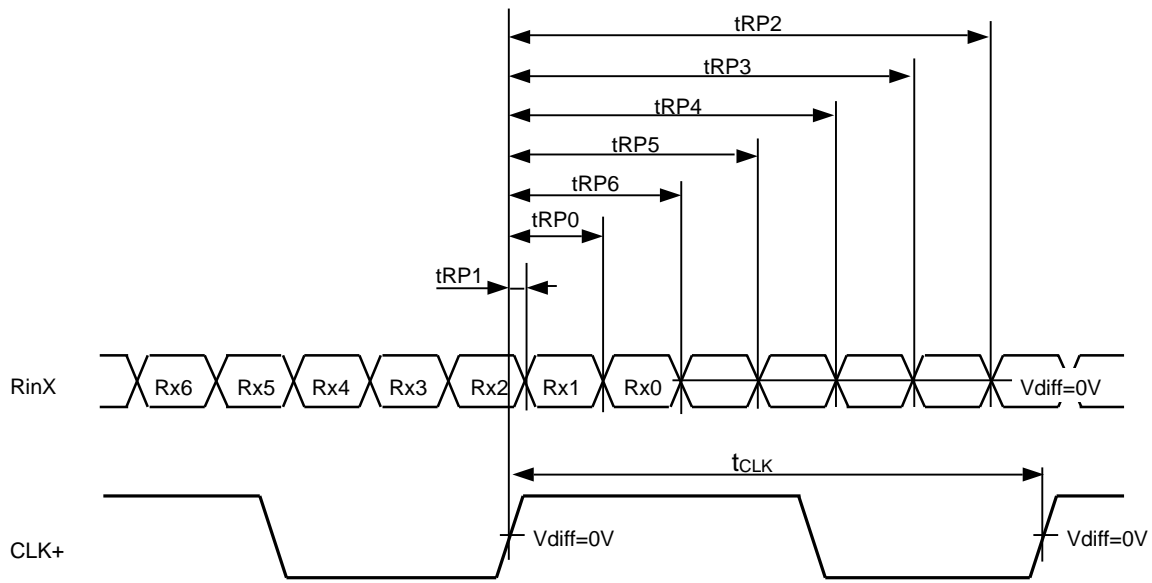

$$RinX = (RinX+) - (RinX-) \quad (X=0, 1, 2, 3)$$

| | Item | Symbol | Min. | Typ. | Max. | Unit |
|---------------------|-------------------|-------------|------------------------|-----------------|------------------------|------|
| CLK | Cycle frequency | $1/t_{CLK}$ | 80 | 100 | 120 | MHz |
| RinX (X=0,1,2,3) | 0 data position | t_{RP0} | $1/7 * t_{CLK} - 0.22$ | $1/7 * t_{CLK}$ | $1/7 * t_{CLK} + 0.22$ | ns |
| | 1st data position | t_{RP1} | -0.22 | 0 | +0.22 | |
| | 2nd data position | t_{RP2} | $6/7 * t_{CLK} - 0.22$ | $6/7 * t_{CLK}$ | $6/7 * t_{CLK} + 0.22$ | |
| | 3rd data position | t_{RP3} | $5/7 * t_{CLK} - 0.22$ | $5/7 * t_{CLK}$ | $5/7 * t_{CLK} + 0.22$ | |
| | 4th data position | t_{RP4} | $4/7 * t_{CLK} - 0.22$ | $4/7 * t_{CLK}$ | $4/7 * t_{CLK} + 0.22$ | |
| | 5th data position | t_{RP5} | $3/7 * t_{CLK} - 0.22$ | $3/7 * t_{CLK}$ | $3/7 * t_{CLK} + 0.22$ | |
| | 6th data position | t_{RP6} | $2/7 * t_{CLK} - 0.22$ | $2/7 * t_{CLK}$ | $2/7 * t_{CLK} + 0.22$ | |

9.7 DATA INPUT for DISPLAY COLOR

| color | Input | Red Data | | | | | | | | Green Data | | | | | | | | Blue Data | | | | | | | |
|-------------|------------|----------|----|----|----|-----|----|----|----|------------|----|----|----|-----|----|----|----|-----------|----|----|----|-----|----|----|----|
| | | R7 | R6 | R5 | R4 | R3 | R2 | R1 | R0 | G7 | G6 | G5 | G4 | G3 | G2 | G1 | G0 | B7 | B6 | B5 | B4 | B3 | B2 | B1 | B0 |
| | | MSB | | | | LSB | | | | MSB | | | | LSB | | | | MSB | | | | LSB | | | |
| Basic Color | Black | 0 | 0 | 0 | 0 | 0 | 0 | 0 | 0 | 0 | 0 | 0 | 0 | 0 | 0 | 0 | 0 | 0 | 0 | 0 | 0 | 0 | 0 | 0 | |
| | Red(255) | 1 | 1 | 1 | 1 | 1 | 1 | 1 | 1 | 0 | 0 | 0 | 0 | 0 | 0 | 0 | 0 | 0 | 0 | 0 | 0 | 0 | 0 | 0 | |
| | Green(255) | 0 | 0 | 0 | 0 | 0 | 0 | 0 | 0 | 1 | 1 | 1 | 1 | 1 | 1 | 1 | 1 | 0 | 0 | 0 | 0 | 0 | 0 | 0 | |
| | Blue(255) | 0 | 0 | 0 | 0 | 0 | 0 | 0 | 0 | 0 | 0 | 0 | 0 | 0 | 0 | 0 | 1 | 1 | 1 | 1 | 1 | 1 | 1 | 1 | |
| | Cyan | 0 | 0 | 0 | 0 | 0 | 0 | 0 | 0 | 1 | 1 | 1 | 1 | 1 | 1 | 1 | 1 | 1 | 1 | 1 | 1 | 1 | 1 | 1 | |
| | Magenta | 1 | 1 | 1 | 1 | 1 | 1 | 1 | 1 | 0 | 0 | 0 | 0 | 0 | 0 | 0 | 1 | 1 | 1 | 1 | 1 | 1 | 1 | 1 | |
| | Yellow | 1 | 1 | 1 | 1 | 1 | 1 | 1 | 1 | 1 | 1 | 1 | 1 | 1 | 1 | 1 | 0 | 0 | 0 | 0 | 0 | 0 | 0 | 0 | |
| | White | 1 | 1 | 1 | 1 | 1 | 1 | 1 | 1 | 1 | 1 | 1 | 1 | 1 | 1 | 1 | 1 | 1 | 1 | 1 | 1 | 1 | 1 | 1 | |
| Red | Black | 0 | 0 | 0 | 0 | 0 | 0 | 0 | 0 | 0 | 0 | 0 | 0 | 0 | 0 | 0 | 0 | 0 | 0 | 0 | 0 | 0 | 0 | | |
| | Red(1) | 0 | 0 | 0 | 0 | 0 | 0 | 0 | 1 | 0 | 0 | 0 | 0 | 0 | 0 | 0 | 0 | 0 | 0 | 0 | 0 | 0 | 0 | | |
| | Red(2) | 0 | 0 | 0 | 0 | 0 | 0 | 1 | 0 | 0 | 0 | 0 | 0 | 0 | 0 | 0 | 0 | 0 | 0 | 0 | 0 | 0 | 0 | | |
| | : | : | : | : | : | : | : | : | : | : | : | : | : | : | : | : | : | : | : | : | : | : | : | | |
| | : | : | : | : | : | : | : | : | : | : | : | : | : | : | : | : | : | : | : | : | : | : | : | | |
| | Red(253) | 1 | 1 | 1 | 1 | 1 | 1 | 0 | 1 | 0 | 0 | 0 | 0 | 0 | 0 | 0 | 0 | 0 | 0 | 0 | 0 | 0 | 0 | | |
| | Red(254) | 1 | 1 | 1 | 1 | 1 | 1 | 1 | 0 | 0 | 0 | 0 | 0 | 0 | 0 | 0 | 0 | 0 | 0 | 0 | 0 | 0 | 0 | | |
| | Red(255) | 1 | 1 | 1 | 1 | 1 | 1 | 1 | 1 | 0 | 0 | 0 | 0 | 0 | 0 | 0 | 0 | 0 | 0 | 0 | 0 | 0 | 0 | | |
| Green | Black | 0 | 0 | 0 | 0 | 0 | 0 | 0 | 0 | 0 | 0 | 0 | 0 | 0 | 0 | 0 | 0 | 0 | 0 | 0 | 0 | 0 | 0 | | |
| | Green(1) | 0 | 0 | 0 | 0 | 0 | 0 | 0 | 0 | 0 | 0 | 0 | 0 | 0 | 0 | 1 | 0 | 0 | 0 | 0 | 0 | 0 | 0 | | |
| | Green(2) | 0 | 0 | 0 | 0 | 0 | 0 | 0 | 0 | 0 | 0 | 0 | 0 | 0 | 1 | 0 | 0 | 0 | 0 | 0 | 0 | 0 | 0 | | |
| | : | : | : | : | : | : | : | : | : | : | : | : | : | : | : | : | : | : | : | : | : | : | : | | |
| | : | : | : | : | : | : | : | : | : | : | : | : | : | : | : | : | : | : | : | : | : | : | : | | |
| | Green(253) | 0 | 0 | 0 | 0 | 0 | 0 | 0 | 0 | 1 | 1 | 1 | 1 | 1 | 1 | 0 | 1 | 0 | 0 | 0 | 0 | 0 | 0 | | |
| | Green(254) | 0 | 0 | 0 | 0 | 0 | 0 | 0 | 0 | 1 | 1 | 1 | 1 | 1 | 1 | 0 | 0 | 0 | 0 | 0 | 0 | 0 | 0 | | |
| | Green(255) | 0 | 0 | 0 | 0 | 0 | 0 | 0 | 0 | 1 | 1 | 1 | 1 | 1 | 1 | 1 | 0 | 0 | 0 | 0 | 0 | 0 | 0 | | |
| Blue | Black | 0 | 0 | 0 | 0 | 0 | 0 | 0 | 0 | 0 | 0 | 0 | 0 | 0 | 0 | 0 | 0 | 0 | 0 | 0 | 0 | 0 | 0 | | |
| | Blue(1) | 0 | 0 | 0 | 0 | 0 | 0 | 0 | 0 | 0 | 0 | 0 | 0 | 0 | 0 | 0 | 0 | 0 | 0 | 0 | 0 | 0 | 1 | | |
| | Blue(2) | 0 | 0 | 0 | 0 | 0 | 0 | 0 | 0 | 0 | 0 | 0 | 0 | 0 | 0 | 0 | 0 | 0 | 0 | 0 | 0 | 1 | 0 | | |
| | : | : | : | : | : | : | : | : | : | : | : | : | : | : | : | : | : | : | : | : | : | : | : | | |
| | : | : | : | : | : | : | : | : | : | : | : | : | : | : | : | : | : | : | : | : | : | : | : | | |
| | Blue(253) | 0 | 0 | 0 | 0 | 0 | 0 | 0 | 0 | 0 | 0 | 0 | 0 | 0 | 0 | 0 | 1 | 1 | 1 | 1 | 1 | 1 | 0 | | |
| | Blue(254) | 0 | 0 | 0 | 0 | 0 | 0 | 0 | 0 | 0 | 0 | 0 | 0 | 0 | 0 | 0 | 1 | 1 | 1 | 1 | 1 | 1 | 0 | | |
| | Blue(255) | 0 | 0 | 0 | 0 | 0 | 0 | 0 | 0 | 0 | 0 | 0 | 0 | 0 | 0 | 0 | 1 | 1 | 1 | 1 | 1 | 1 | 1 | | |

9.8 POWER SEQUENCE

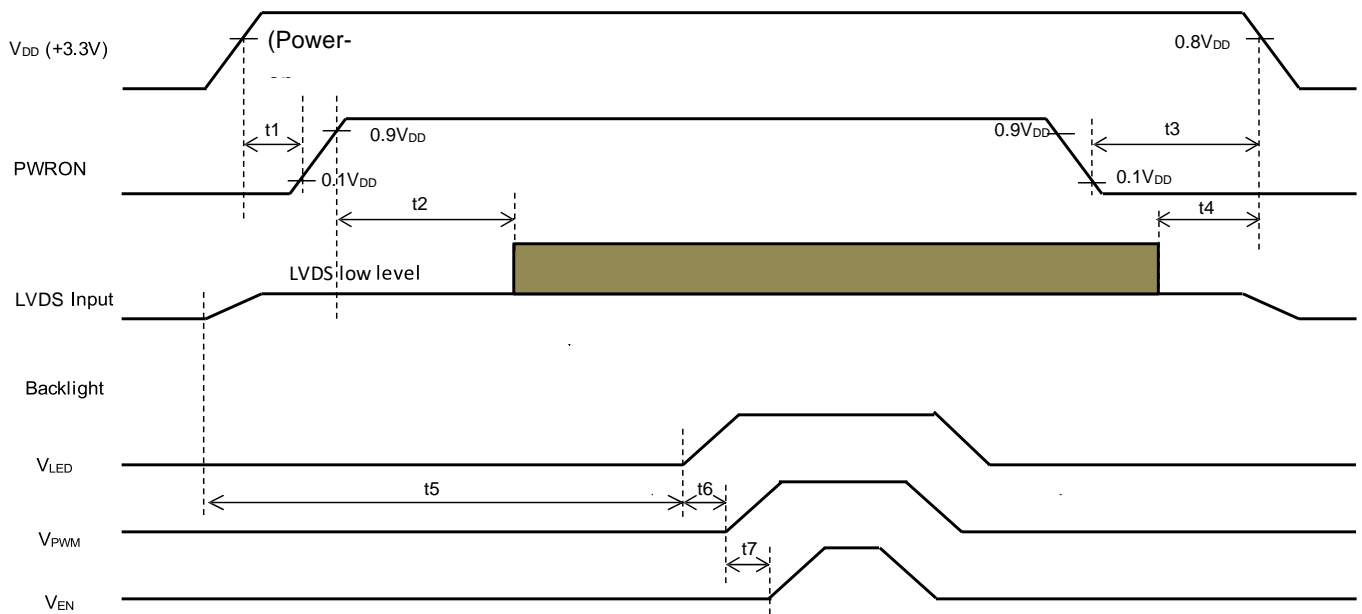

| Symbol | Item | Min | Typ | Max | Unit | Remarks |
|--------|--|-----|-----|-----|------|---------|
| t1 | Period from Power-on(3.3V) to PWRON↑ | 0 | - | 100 | ms | |
| t2 | Period from Power-on(3.3V) to LVDS input-on | 0 | - | - | ms | |
| t3 | Period from PWRON↓ to Power-off(3.3V) | 100 | - | 500 | ms | |
| t4 | Period from LVDS input-off to Power-off(3.3V) | 0 | - | - | ms | |
| t5 | Period from LVDS input-on to V _{LED} -on | 500 | - | - | ms | |
| t6 | Period from V _{LED} input-on to V _{PWM} on | 1 | - | - | ms | |
| t7 | Period from V _{PWM} input-on to V _{EN} on | 1 | - | - | ms | |

Note 1:

- When power supply is OFF ($V_{DD}=0V$), logic input must be kept at either V_{SS} level or high impedance
- The rising speed of power supply ($V_{DD}=+3.3V$) should be less than $2V/100\mu s$.
- When the PWRON signal is 0V, V_{DD} must be 0V. (However t1 and t7 except)
- LVDS signal level of the invalid period may be within the absolute maximum rating.

Note 2: In order to avoid high Inrush current, V_{DD} and V_{LED} rising time need to set more than 0.5ms.

10. OUTLINE DIMENSIONS

10.1 FRONT VIEW

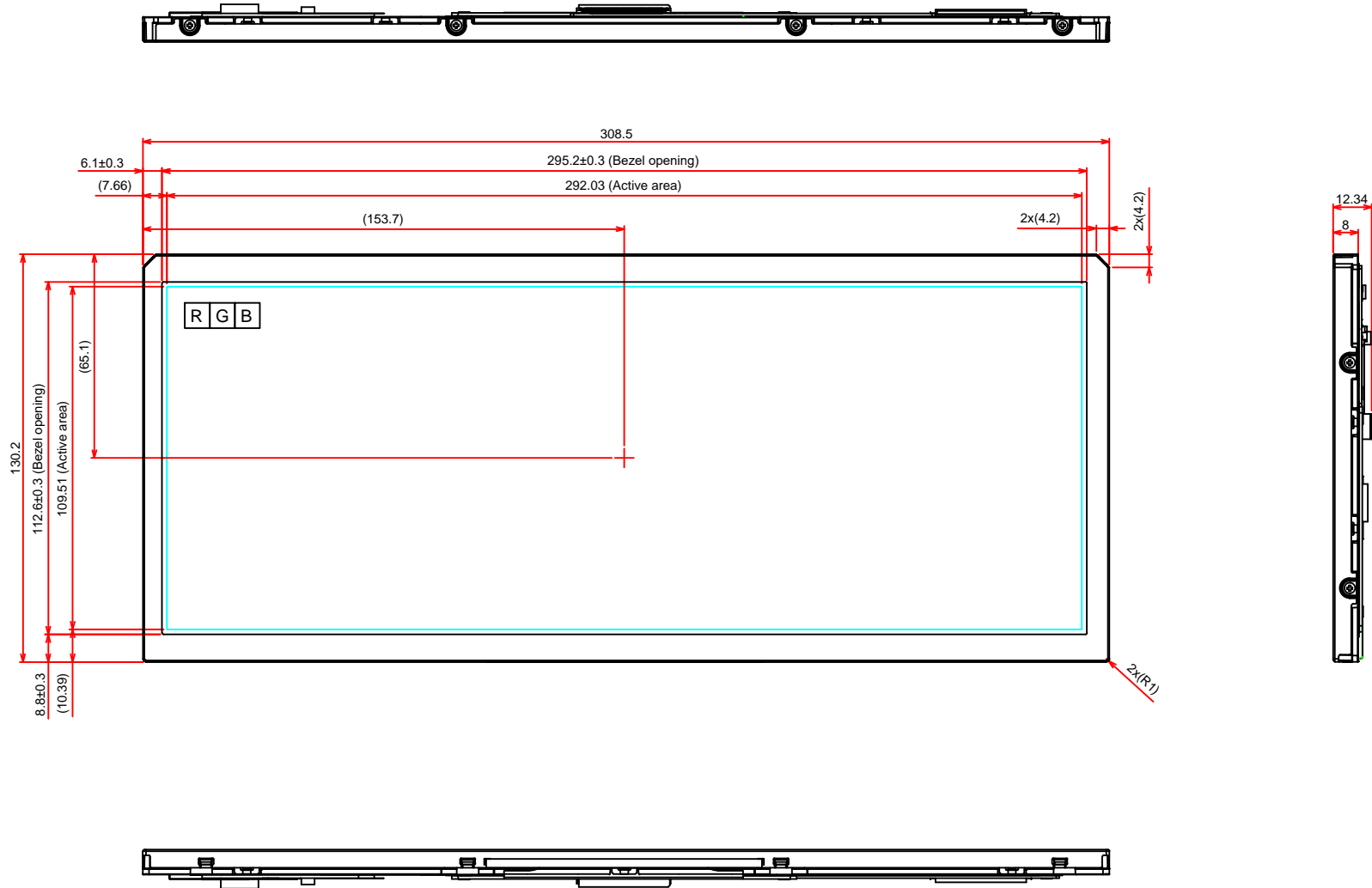

General Tolerance: ± 0.5 mm
 Scale : NTS
 Unit : mm

10.2 RAER VIEW

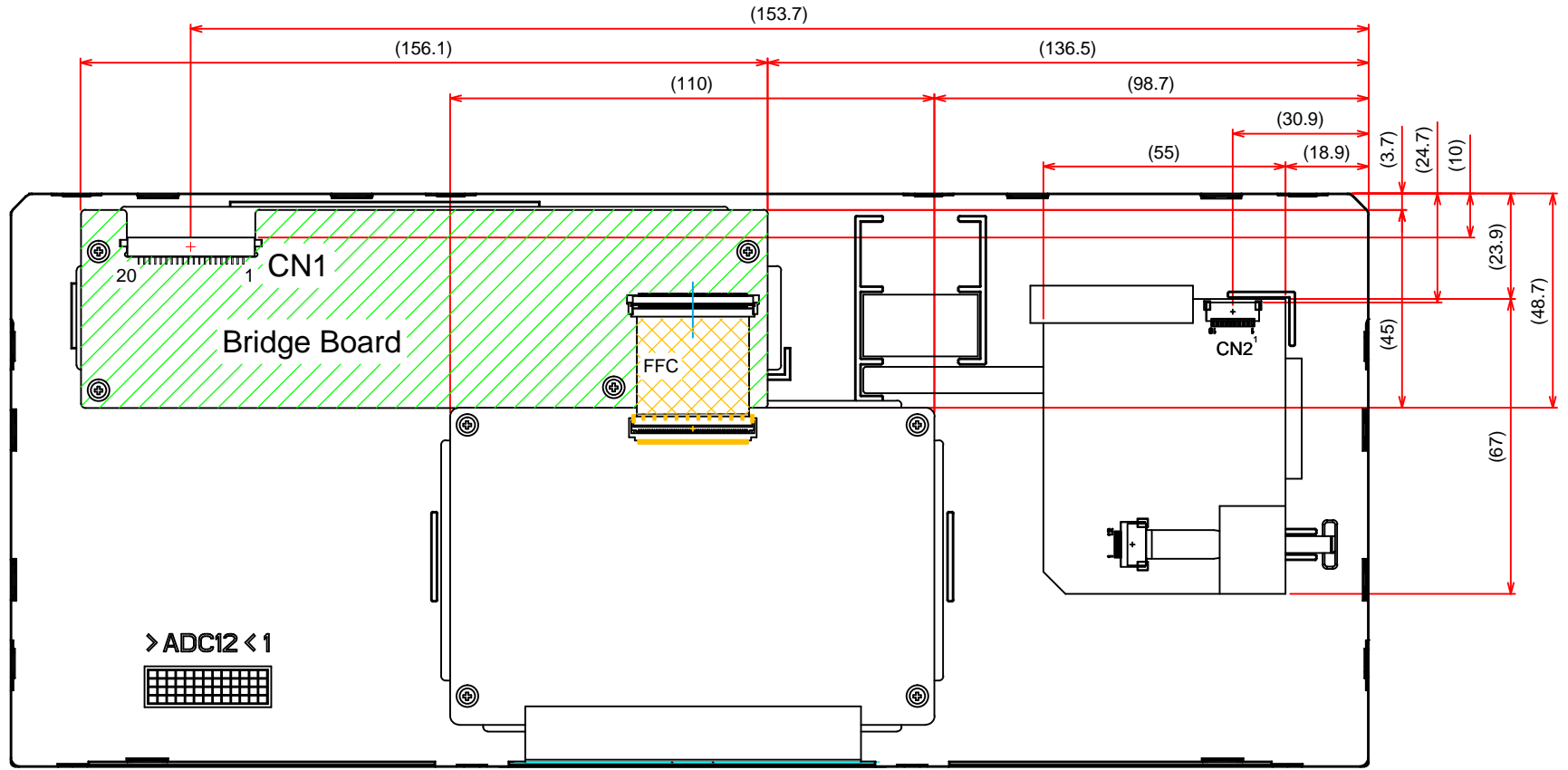

General Tolerance: ±0.5mm
 Scale : NTS
 Unit : mm

11. APPEARANCE STANDARD

The appearance inspection is performed in a room around 500~1000 lx based on the conditions as below:

- The distance between inspector's eyes and display is 30 cm.
- The viewing zone is defined with angle θ shown in Fig. 11.1 The inspection should be performed within 45° when display is shut down. The inspection should be performed within 5° when display is power on.

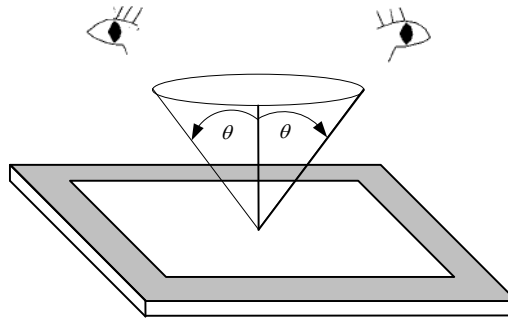

Fig. 11.1

11.1 THE DEFINITION OF LCD ZONE

LCD panel is divided into 3 areas as shown in Fig.11.2 for appearance specification in next section. A zone is the LCD active area (dot area); B zone is the area between A zone and metal frame.

In terms of housing design, B zone is the recommended window area customers' housing should be located in.

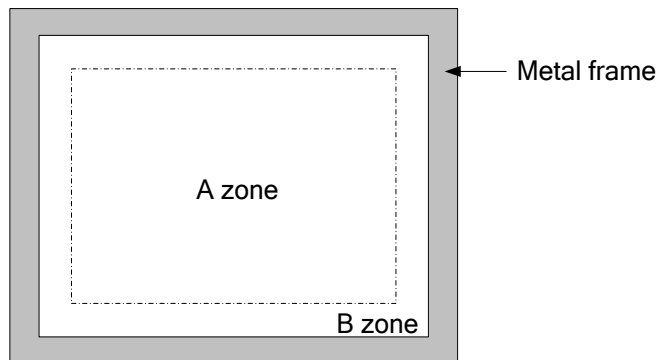

Fig. 11.2

11.2 LCD APPEARANCE SPECIFICATION

The specification as below is defined as the amount of unexpected phenomenon or material in different zones of LCD panel. The definitions of length, width and average diameter using in the table are shown in Fig. 11.3 and Fig. 11.4.

| Item | Criteria | | | | Applied zone |
|---|---------------------------------------|-------------------------|----------------|----------------|--------------|
| | Length (mm) | Width (mm) | Maximum number | Minimum space | |
| Scratches | Ignored | $W \leq 0.02$ | Ignored | - | A, B |
| | $L \leq 40$ | $0.02 < W \leq 0.04$ | 10 | - | |
| | - | $0.04 < W$ | Not allowed | - | |
| | Serious one is not allowed | | | | |
| Dent | Serious one is not allowed | | | | A |
| Wrinkles in polarizer | Serious one is not allowed | | | | A |
| Bubbles on polarizer | Average diameter (mm) | | Maximum number | | A |
| | $D \leq 0.3$ | | Ignored | | |
| | $0.3 < D \leq 0.5$ | | 12 | | |
| | $0.5 < D$ | | Not allowed | | |
| 1) Stains 2) Foreign Materials 3) Dark Spot | Filamentous (Line shape) | | | | A, B |
| | Length (mm) | Width (mm) | Maximum number | | |
| | $L \leq 2.0$ | $W \leq 0.03$ | Ignored | | |
| | $L \leq 3.0$ | $0.03 < W \leq 0.05$ | 10 | | |
| | $L \leq 2.5$ | $0.05 < W \leq 0.1$ | 1 | | |
| | Round (Dot shape) | | | | A, B |
| | Average diameter (mm) | Maximum number | Minimum Space | | |
| | $D \leq 0.2$ | Ignored | - | | |
| | $0.2 < D \leq 0.3$ | 10 | 10 mm | | |
| | $0.3 < D \leq 0.4$ | 5 | 30 mm | | |
| | $0.4 < D$ | Not allowed | - | | |
| | In total | Filamentous + Round=10 | | | |
| | Those wiped out easily are acceptable | | | | |
| | Dot-Defect | Bright dot-defect | Type | Maximum number | |
| 1 dot | | | 0 | | |
| 2 adjacent dot | | | 0 | | |
| 3 adjacent dot or above | | | Not allowed | | |
| In total | | 0 | | | |
| Dark dot-defect | | 1 dot | 5 | | |
| | | 2 adjacent dot | 2 | | |
| | | 3 adjacent dot or above | Not allowed | | |
| | | In total | 5 | | |
| In total | | 5 | | | |

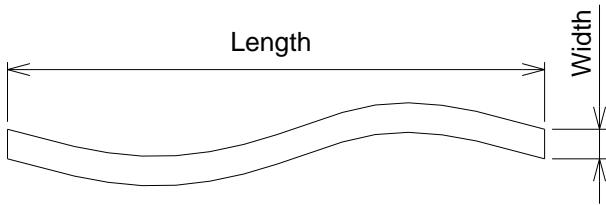

Fig 11.3

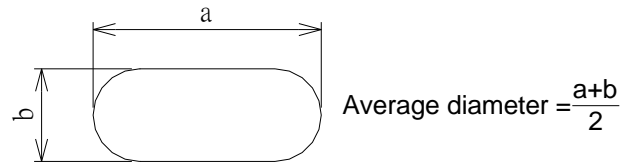
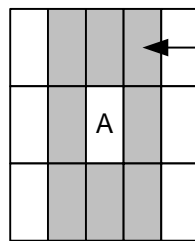

Fig 11.4

Note 1: The definitions of dot defect are as below:

- The defect area of the dot must be bigger than half of a dot.
- For bright dot-defect, showing black pattern, the dot's brightness must be over 30% brighter than others.
- For dark dot-defect, showing white pattern, the dot's brightness must be under 70% darker than others.
- The definition of 1-dot-defect is the defect-dot, which is isolated and no adjacent defect-dot.
- The definition of adjacent dot is shown as Fig. 11.5.
- The Density of dot defect is defined in the area within diameter $\phi = 20\text{mm}$.



The dots colored gray are adjacent to defect-dot A.

Fig 11.5

12. PRECAUTIONS

12.1 PRECAUTIONS of ESD

- 1) Before handling the display, please ensure your body has been connected to ground to avoid any damages by ESD. Also, do not touch display's interface directly when assembling.
- 2) Please remove the protection film very slowly before turning on the display to avoid generating ESD.

12.2 PRECAUTIONS of HANDLING

- 1) In order to keep the appearance of display in good condition, please do not rub any surfaces of the displays by sharp tools harder than 3H, especially touch panel, metal frame and polarizer.
- 2) Please do not pile the displays in order to avoid any scars leaving on the display. In order to avoid any injuries, please pay more attention for the edges of glasses and metal frame, and wear finger cots to protect yourself and the display before working on it.
- 3) Touching the display area or the terminal pins with bare hand is prohibited. This is because it will stain the display area and cause poor insulation between terminal pins, and might affect display's electrical characteristics furthermore.
- 4) Do not use any harmful chemicals such as acetone, toluene, and isopropyl alcohol to clean display's surfaces.
- 5) Please use soft cloth or absorbent cotton with ethanol to clean the display by gently wiping. Moreover, when wiping the display, please wipe it by horizontal or vertical direction instead of circling to prevent leaving scars on the display's surface, especially polarizer.
- 6) Please wipe any unknown liquids immediately such as saliva, water or dew on the display to avoid color fading or any permanently damages.
- 7) Maximum pressure to the surface of the display must be less than 1.96×10^4 Pa. If the area of adding pressure is less than 1 cm^2 , the maximum pressure must be less than 1.96N.

12.3 PRECAUTIONS OF OPERATING

- 1) Please input signals and voltages to the displays according to the values defined in the section of electrical characteristics to obtain the best performance. Any voltages over than absolute maximum rating will cause permanent damages to this display. Also, any timing of the signals out of this specification would cause unexpected performance.
- 2) When the display is operating at significant low temperature, the response time will be slower than it at 25 C° . In high temperature, the color will be slightly dark and blue compared to original pattern. However, these are temperature-related phenomenon of LCD and it will not cause permanent damages to the display when used within the operating temperature.
- 3) The use of screen saver or sleep mode is recommended when static images are likely for long periods of time. This is to avoid the possibility of image sticking.
- 4) Spike noise can cause malfunction of the circuit. The recommended limitation of spike noise is no bigger than $\pm 100 \text{ mV}$.

12.4 PRECAUTIONS of STORAGE

If the displays are going to be stored for years, please be aware the following notices.

- 1) Please store the displays in a dark room to avoid any damages from sunlight and other sources of UV light.
- 2) The recommended long term storage temperature is between 10 C° ~35 C° and 55%~75% humidity to avoid causing bubbles between polarizer and LCD glasses, and polarizer peeling from LCD glasses.
- 3) It would be better to keep the displays in the container, which is shipped from JDI, and do not unpack it.
- 4) Please do not stick any labels on the display surface for a long time, especially on the polarizer.

13. DESIGNATION of LOT MARK

1) The lot mark is showing in Fig.13.1. First 4 digits are used to represent production lot, T represented made in Taiwan, and the last 6 digits are the serial number.

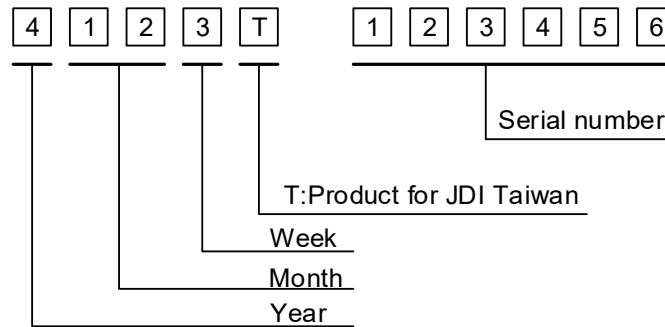

Fig 13.1

2) The tables as below are showing what the first 4 digits of lot mark are shorted for.

| Year | Lot Mark |
|------|----------|
| 2024 | 4 |
| 2025 | 5 |
| 2026 | 6 |
| 2027 | 7 |
| 2028 | 8 |

| Month | Lot Mark | Month | Lot Mark |
|-------|----------|-------|----------|
| Jan. | 01 | Jul. | 07 |
| Feb. | 02 | Aug. | 08 |
| Mar. | 03 | Sep. | 09 |
| Apr. | 04 | Oct. | 10 |
| May | 05 | Nov. | 11 |
| Jun. | 06 | Dec. | 12 |

| Week | Lot Mark |
|------------|----------|
| 1~7 days | 1 |
| 8~14 days | 2 |
| 15~21 days | 3 |
| 22~28 days | 4 |
| 29~31 days | 5 |

3) Except letters I and O, revision number will be shown on lot mark and following letters A to Z.

4) The location of the lot mark is on the back of the display shown in Fig. 13.2.

Label example:



Fig. 13.2