

HITACHI

KAOHSIUNG HITACHI ELECTRONICS CO., LTD.

FOR MESSRS: _____

DATE: Aug. 06th 2010

CUSTOMER'S ACCEPTANCE SPECIFICATIONS

TX31D36VM2EAA

Contents

No.	ITEM	SHEET No.	PAGE
1	COVER	7B64PS 2701-TX31D36VM2EAA-1	1-1/1
2	RECORD OF REVISION	7B64PS 2702-TX31D36VM2EAA-1	2-1/1
3	GENERAL DATA	7B64PS 2703-TX31D36VM2EAA-1	3-1/1
4	ABSOLUTE MAXIMUM RATINGS	7B64PS 2704-TX31D36VM2EAA-1	4-1/1
5	ELECTRICAL CHARACTERISTICS	7B64PS 2705-TX31D36VM2EAA-1	5-1/2~2/2
6	OPTICAL CHARACTERISTICS	7B64PS 2706-TX31D36VM2EAA-1	6-1/3~3/3
7	BLOCK DIAGRAM	7B64PS 2707-TX31D36VM2EAA-1	7-1/1
8	RELIABILITY TESTS	7B64PS 2708-TX31D36VM2EAA-1	8-1/1
9	LCD INTERFACE	7B64PS 2709-TX31D36VM2EAA-1	9-1/12~12/12
10	OUTLINE DIMENSIONS	7B63PS 2710-TX31D36VM2EAA-1	10-1/2~2/2
11	APPEARANCE STANDARD	7B64PS 2711-TX31D36VM2EAA-1	11-1/3~3/3
12	PRECAUTIONS	7B64PS 2712-TX31D36VM2EAA-1	12-1/2~2/2
13	DESIGNATION OF LOT MARK	7B64PS 2713-TX31D36VM2EAA-1	13-1/1

ACCEPTED BY: _____

PROPOSED BY: *Dan Cheng*



2. RECORD OF REVISION

DATE	SHEET No.	SUMMARY

KAOHSIUNG HITACHI ELECTRONICS CO., LTD.	SHEET NO.	7B64PS 2702-TX31D36VM2EAA-1	PAGE	2-1/1
--	--------------	-----------------------------	------	-------

3. GENERAL DATA

3.1 DISPLAY FEATURES

This module is a 12.1" SVGA of 4:3 format amorphous silicon TFT. The pixel format is vertical stripe and sub pixels are arranged as R (red), G (green), B (blue) sequentially. This display is RoHS compliant, COG (chip on glass) technology and LED backlight are applied on this display.

Part Name	TX31D36VM2EAA
Module Dimensions	280.0(W) mm x 210.0(H) mm x 11.0(D) mm typ.
LCD Active Area	246.0(W) mm x 184.5(H) mm
Pixel Pitch	0.3075(W) mm x 0.3075 (H) mm
Resolution	800 x 3(RGB)(W) x 600(H) dots
Color Pixel Arrangement	R, G, B Vertical stripe
LCD Type	Transmissive Color TFT; Normally White; Anti-Reflection Polarizer
Display Type	Active Matrix
Number of Colors	16.7M Colors (R.G.B 8bits digital each)
Backlight	LED
Weight	(680g)
Interface	LVDS; 1ch 8bits 20pins
Power Supply Voltage	3.3V for LCD; 12V for Backlight
Power Consumption	(1.5W) for LCD; (13.4W) typ. for Backlight
Viewing Direction	12 o'clock (The direction without image inversion and least brightness change)

4. ABSOLUTE MAXIMUM RATINGS

Item	Symbol	Min.	Max.	Unit	Remarks
Supply Voltage	VDD	0	4.0	V	-
Input Voltage of Logic and LVDS	VI / V _{TH}	-0.3	VDD+0.3	V	Note 1
Operating Temperature	Top	-20	70	°C	Note 2
Storage Temperature	Tst	-30	80	°C	Note 2
Backlight Input Voltage	VLED	10.0	17.0	V	Note 3

Note 1: It shall be applied to pixel data signal, clock signal and control Pin.

Note 2: The maximum rating is defined as above based on the temperature on the panel surface, which might be different from ambient temperature after assembling the panel into the application. Moreover, some temperature-related phenomenon as below needed to be noticed:

- Background color, contrast and response time would be different in temperatures other than 25°C.
- Operating under high temperature will shorten LED lifetime.

Note 3: Do not operate at or near the maximum rating listed for extended periods of time. Exposure to such conditions may adversely impact product reliability and result in failures not covered by warranty.

5. ELECTRICAL CHARACTERISTICS

5.1 LCD CHARACTERISTICS

 $T_a = 25\text{ }^\circ\text{C}$, $V_{SS} = 0\text{V}$

Item	Symbol	Condition	Min.	Typ.	Max.	Unit	Remarks
Power Supply Voltage	VDD	-	3.0	3.3	3.6	V	-
Differential Input Voltage for LVDS Receiver Threshold	V_{TH}	"H" level	-	-	+100	mV	Note 1
		"L" level	-100	-	-		
Input Voltage for Logic	V_I	"H" level	2.0		VDD	V	Note 2
		"L" level	VSS		0.8		
Power Supply Current	IDD	VDD-VSS =3.3V	-	450	-	mA	Note 3,4,5
Vsync Frequency	f_v	-	-	60	68	Hz	Note 6
Hsync Frequency	f_H	-	-	37.7	42.5	KHz	-
DCLK Frequency	f_{CLK}	-	-	40	45	MHz	-

Note 1: VCM=+1.25V

VCM is common mode voltage of LVDS transmitter/receiver.

The input terminal of LVDS transmitter is terminated with 100Ω.

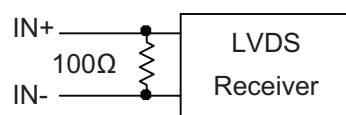

Note 2: The rating is defined for the signal voltages of the interface such as FRC and MSL.

Note 3: $f_v=60\text{Hz}$, $f_{CLK}=40\text{MHz}$, $V_{DD}=3.3\text{V}$, DC Current.

Typical value is measured when displaying vertical 256 gray scale.

Maximum is measured when displaying Vertical-stripe.

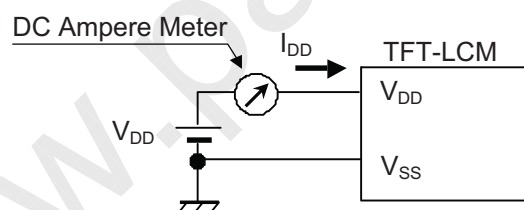

Note 4: 1A fuse is built in the module. Current capacity for VDD power supply should be larger than 2.5A, so that the fuse built in the module (maximum) could appropriately work under the abnormal conditions.

Note 5: For LVDS transmitter input.

Note 6: Vertical Frequency 60Hz is recommended for best optical performance in terms of flicker.

5.2 BACKLIGHT CHARACTERISTICS

 $T_a = 25\text{ }^\circ\text{C}$

Item	Symbol	Condition	Min.	Typ.	Max.	Unit	Remarks
LED Input Voltage	VLED	Backlight Unit	10.8	12.0	13.2	V	Note 1
LED Driving Current (DIM Control)	ILED	DIM=0V;0%Duty	-	1120	-	mA	Note 2,4,5
		DIM=3.3V;100%Duty	-	(6)	-		
LED Lifetime	-	90mA x 4	-	70k	-	hrs	Note 3

Note 1: As Fig 5.1 shown, all LEDs are controlled by the LED Driver when applying 12V VLED.

Note 2: Dimming function can be obtained by applying DC voltage or PWM signal from the display interface CN1. The recommend PWM signal is 1KHz ~ 10KHz with 3.3V amplitude. The brightness is increased when applied DC voltage or PWM duty of DIM Pin is decreased.

Note 3: The estimated lifetime is specified as the time to reduce 50% brightness by applying 90mA x 4 at 25°C.

Note 4: Fuse is built in the module, current capacity for VLED power supply should be larger than 6.25A, so that the fuse built in the module (maximum) could appropriately work under the abnormal conditions.

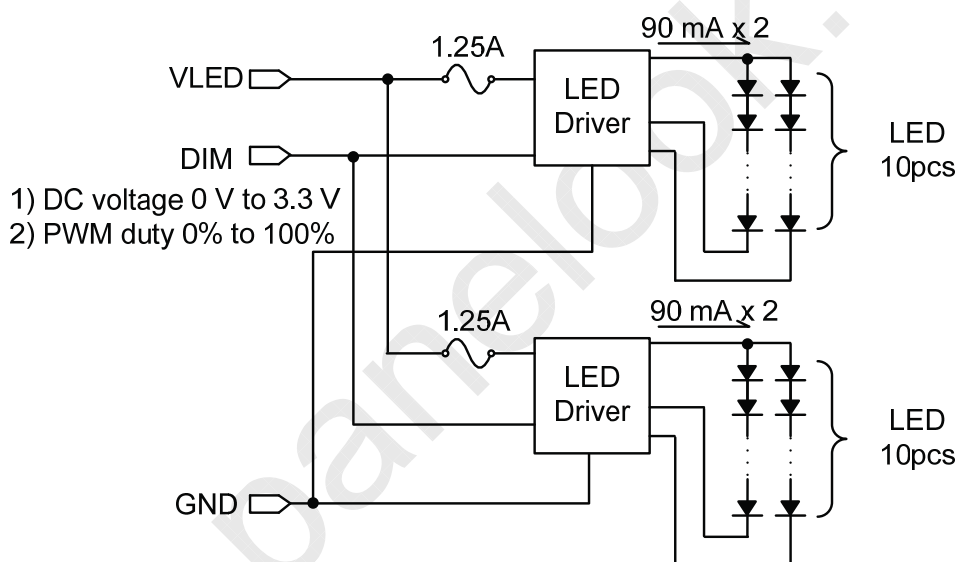

Fig 5.1

Note 5: ILED V.S. DIM voltage (Reference only)

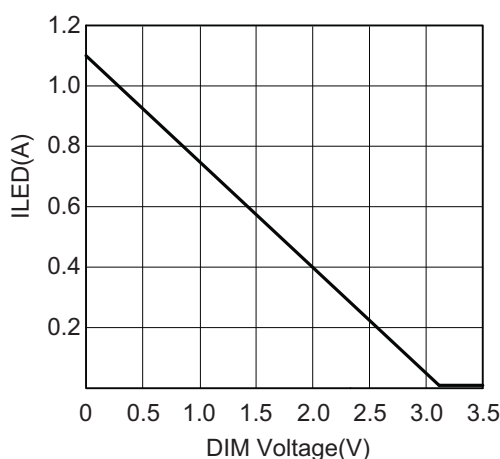

Fig 5.2

6. OPTICAL CHARACTERISTICS

The optical characteristics are measured based on the conditions as below:

- Supplying the signals and voltages defined in the section of electrical characteristics.
- The backlight unit needs to be turned on for 30 minutes.
- The ambient temperature is 25 °C .
- In the dark room around 500~1000 lx, the equipment has been set for the measurements as shown in Fig 6.1.

$$T_a = 25\text{ }^{\circ}\text{C}, f_v = 60\text{ Hz}, VDD = 3.3\text{V}$$

Item	Symbol	Condition	Min.	Typ.	Max.	Unit	Remarks
Brightness of White	-	$\phi = 0^{\circ}, \theta = 0^{\circ}$, DIM=0V	800	1000	-	cd/m ²	Note 1,7
Brightness Uniformity	-		70	-	-	%	Note 2
Contrast Ratio	CR		-	800	-	-	Note 3
Response Time (Rising + Falling)	Rise(Ton)	$\phi = 0^{\circ}, \theta = 0^{\circ}$	-	15	-	ms	Note 4
	Fall(Toff)		-	10	-		
NTSC Ratio	-	$\phi = 0^{\circ}, \theta = 0^{\circ}$	-	(60)	-	%	-
Viewing Angle	θ_x	$\phi = 0^{\circ}, CR \geq 10$	-	80	-	Degree	Note 5
	$\theta_{x'}$	$\phi = 180^{\circ}, CR \geq 10$	-	80	-		
	θ_y	$\phi = 90^{\circ}, CR \geq 10$	-	80	-		
	$\theta_{y'}$	$\phi = 270^{\circ}, CR \geq 10$	-	60	-		
Color Chromaticity	Red	X	-	0.61	-	-	Note 6
		Y	-	0.36	-		
	Green	X	-	0.35	-		
		Y	-	0.59	-		
	Blue	X	-	0.15	-		
		Y	-	0.08	-		
	White	X	-	0.32	-		
		Y	-	0.32	-		

Note 1: The brightness is measured from the panel center point, P5 in Fig. 6.2, for the typical value.

Note 2: The brightness uniformity is calculated by the equation as below:

$$\text{Brightness uniformity} = \frac{\text{Min. Brightness}}{\text{Max. Brightness}} \times 100\%$$

, which is based on the brightness values of the 9 points measured by BM-5A as shown in Fig. 6.2.

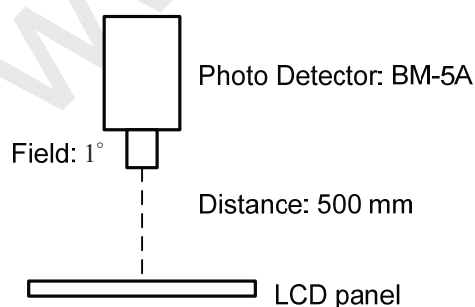

Fig. 6.1

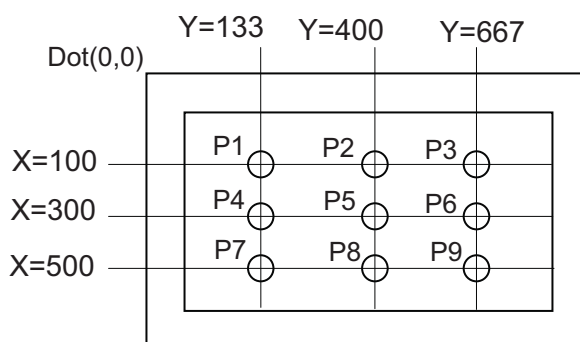

Fig. 6.2

Note 3: The contrast ratio is measured from the center point of the panel, P5, and defined as the following equation:

$$CR = \frac{\text{Brightness of White}}{\text{Brightness of Black}}$$

Note 4: The definition of response time is shown in Fig. 6.3. The rising time is the period from 90% brightness to 10% brightness when the data is from white to black. Oppositely, Falling time is the period from 10% brightness rising to 90% brightness.

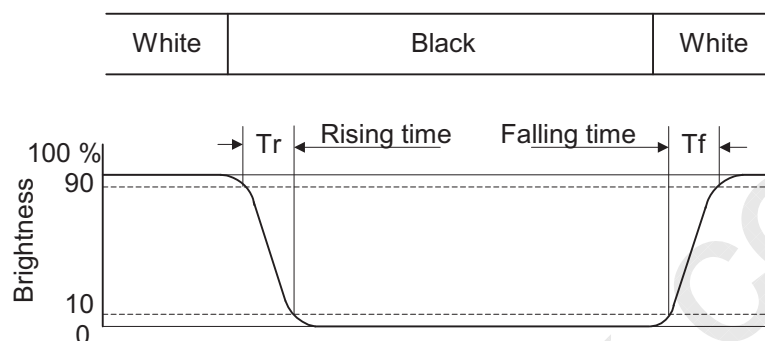

Fig . 6.3

Note 5: The definition of viewing angle is shown in Fig. 6.4. Angle ϕ is used to represent viewing directions, for instance, $\phi = 270^\circ$ means 6 o'clock, and $\phi = 0^\circ$ means 3 o'clock. Moreover, angle θ is used to represent viewing angles from axis Z toward plane XY.

The viewing direction of this display is 12 o'clock, which means that a photograph with gray scale would not be reversed in color and the brightness change would be less from this direction. However, the best contrast peak would be located at 6 o'clock.

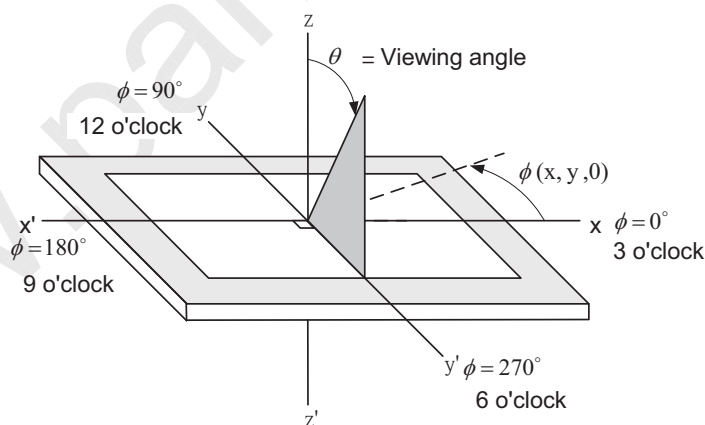
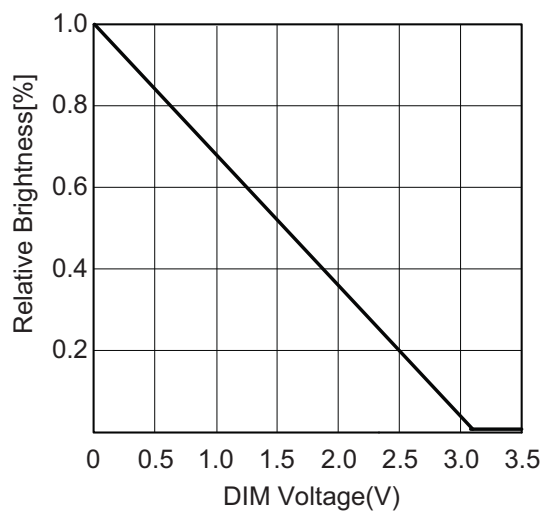

Fig 6.4

Note 6: The color chromaticity is measured from the center point of the panel, P5, as shown in Fig. 6.2.

Note 7: Relative Brightness V.S. DIM Voltage (Reference only)



www.panelook.com

7 BLOCK DIAGRAM

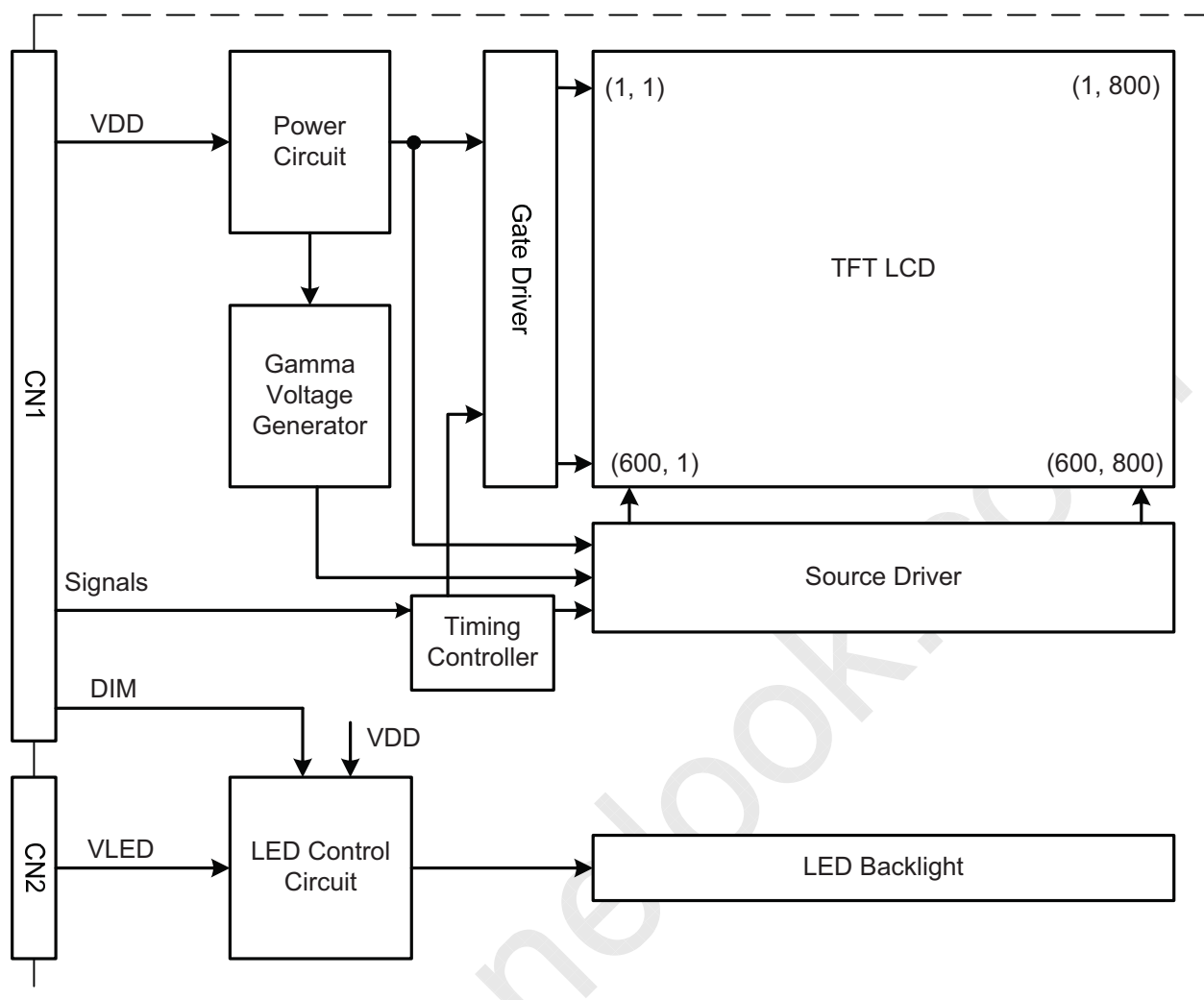

8. RELIABILITY TESTS

Test Item	Condition	
High Temperature	1) Operating 2) 70 °C	240 hrs
Low Temperature	1) Operating 2) -20 °C	240 hrs
High Temperature	1) Storage 2) 80 °C	240 hrs
Low Temperature	1) Storage 2) -30 °C	240 hrs
Heat Cycle	1) Operating 2) -20 °C ~70 °C 3) 3hrs~1hr~3hrs	240 hrs
Thermal Shock	1) Non-Operating 2) -35 °C ↔ 85 °C 3) 0.5 hr ↔ 0.5 hr	240 hrs
High Temperature & Humidity	1) Operating 2) 40 °C & 85%RH 3) Without condensation 4) Note 3	240 hrs
Vibration	1) Non-Operating 2) 20~200 Hz 3) 2G 4) X, Y, and Z directions	1 hr for each direction
Mechanical Shock	1) Non-Operating 2) 10 ms 3) 50G 4) ±X, ±Y and ±Z directions	Once for each direction
ESD	1) Operating 2) Tip: 200 pF, 250 Ω 3) Air discharge for glass: ± 8KV 4) Contact discharge for metal frame: ± 8KV	1) Glass: 9 points 2) Metal frame: 8 points

Note 1: Display functionalities are inspected under the conditions defined in the specification after the reliability tests.

Note 2: The display is not guaranteed for use in corrosive gas environments.

Note 3: Under the condition of high temperature & humidity, if the temperature is higher than 40°C, the humidity needs to be reduced as Fig. 8.1 shown.

Note 4: All pins of LCD interface (CN1) have been tested by ± 100V contact discharge of ESD under non-operating condition.

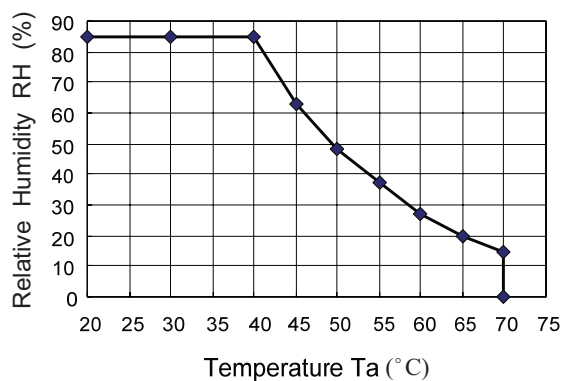

Fig. 8.1

9. LCD INTERFACE

9.1 INTERFACE PIN CONNECTIONS

The display interface connector (CN1) is FI-SEB20P-HF13E-E1500 made by JAE, and pin assignment is as below:

Pin No.	Symbol	Signal	
1	VDD	Power Supply (+3.3V)	Note 1
2	VDD		
3	VSS	GND (0V)	Note 2
4	VSS		
5	IN0-	Pixel Data	Note 3
6	IN0+		
7	VSS	GND (0V)	Note 2
8	IN1-	Pixel Data	Note 3
9	IN1+		
10	VSS	GND (0V)	Note 2
11	IN2-	Pixel Data	Note 3
12	IN2+		
13	VSS	GND (0V)	Note 2
14	CLK IN-	Clock	Note 3
15	CLK IN+		
16	FRC	L:6 bit Mode H:8 bit Mode	Note 2
17	IN3-	Pixel Data	Note 3
18	IN3+		
19	MSL	LVDS Format Setting (Refer to P9-3/12)	
20	DIM	Dimming function	

Note 1: All VDD pins should be connected to +3.3V.

Note 2: All VSS pins should be connected to GND(0V),Metal bezel is connected internally to VSS.

Note 3: IN n- and IN n+ (n=0,1,2,3),CLK IN- and CLK IN+ should be wired by twist-pairs or side-by-side FPC patterns respectively.

The backlight interface connector is SM08BSRSS-TB made by JST, and pin assignment of backlight is as below:

Pin No.	Signal	Level	Function
1 ~ 3	VLED	-	Power Supply for LED
4 ~ 5	NC	-	No connection
6 ~ 8	GND	-	GND

9.2 LVDS INTERFACE

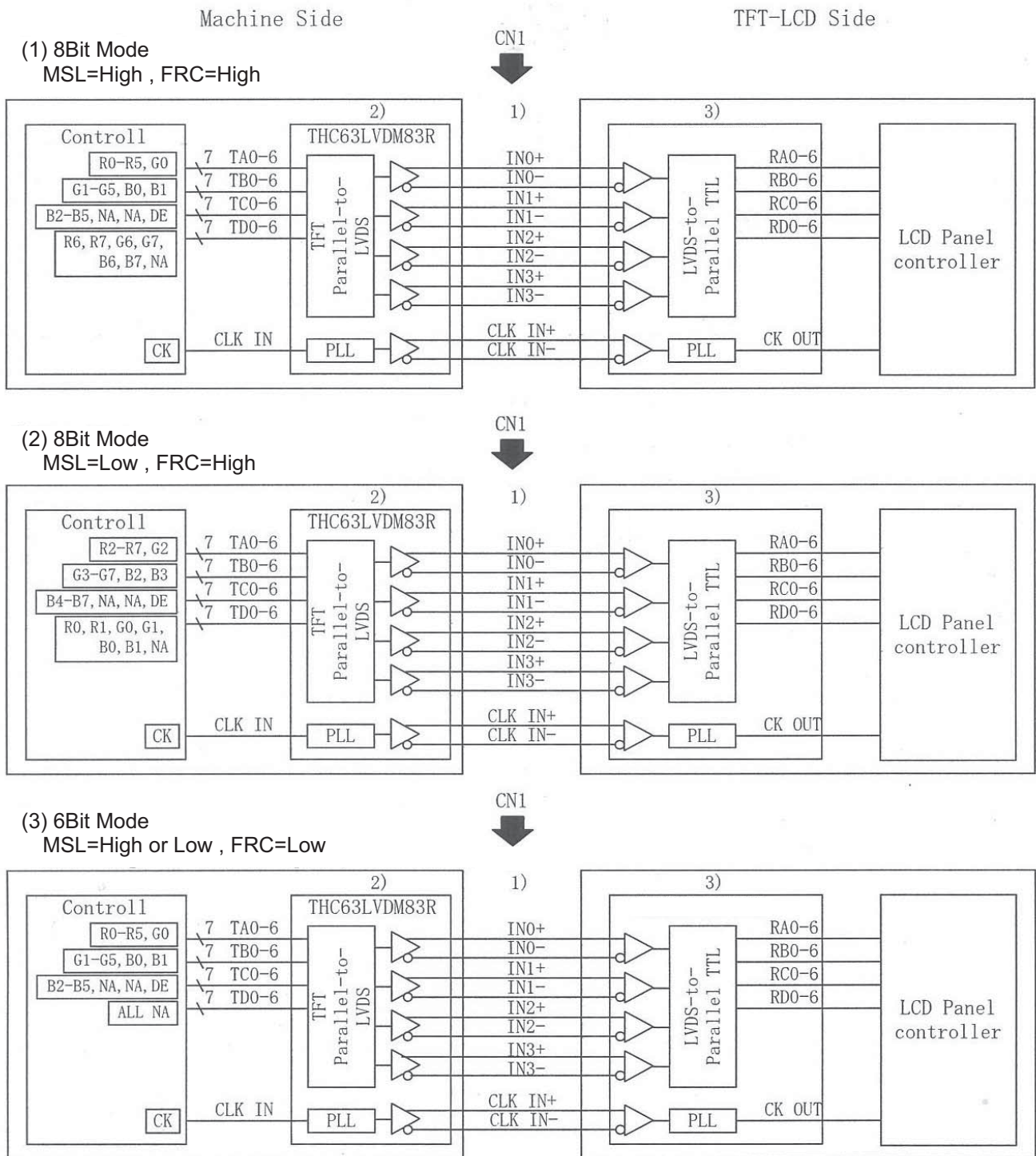

Note 1: LVDS cable impedance should be 100 ohms per signal line when each 2-lines(+,-) is used in differential mode.

Note 2: Transmitter Made by Thine : THC63LVDM83R equivalent.

Transmitter is not contained in Module.

Note 3: Receiver is built in the module.

9.3 LVDS DATA MAPPING

1) 8 Bit Mode

Note : Assignment for (THC63LVDM83R)

Transmitter		MSL	
Pin No.	Date	=High	=Low
51	TA0	R0 (LSB)	R2
52	TA1	R1	R3
54	TA2	R2	R4
55	TA3	R3	R5
56	TA4	R4	R6
3	TA5	R5	R7 (MSB)
4	TA6	G0 (LSB)	G2
6	TB0	G1	G3
7	TB1	G2	G4
11	TB2	G3	G5
12	TB3	G4	G6
14	TB4	G5	G7 (MSB)
15	TB5	B0 (LSB)	B2
19	TB6	B1	B3
20	TC0	B2	B4
22	TC1	B3	B5
23	TC2	B4	B6
24	TC3	B5	B7 (MSB)
27	TC4	(NA)	(NA)
28	TC5	(NA)	(NA)
30	TC6	DE	DE
50	TD0	R6	R0 (LSB)
2	TD1	R7 (MSB)	R1
8	TD2	G6	G0 (LSB)
10	TD3	G7 (MSB)	G1
16	TD4	B6	B0 (LSB)
18	TD5	B7 (MSB)	B1
25	TD6	(NA)	(NA)

< MSL=High >

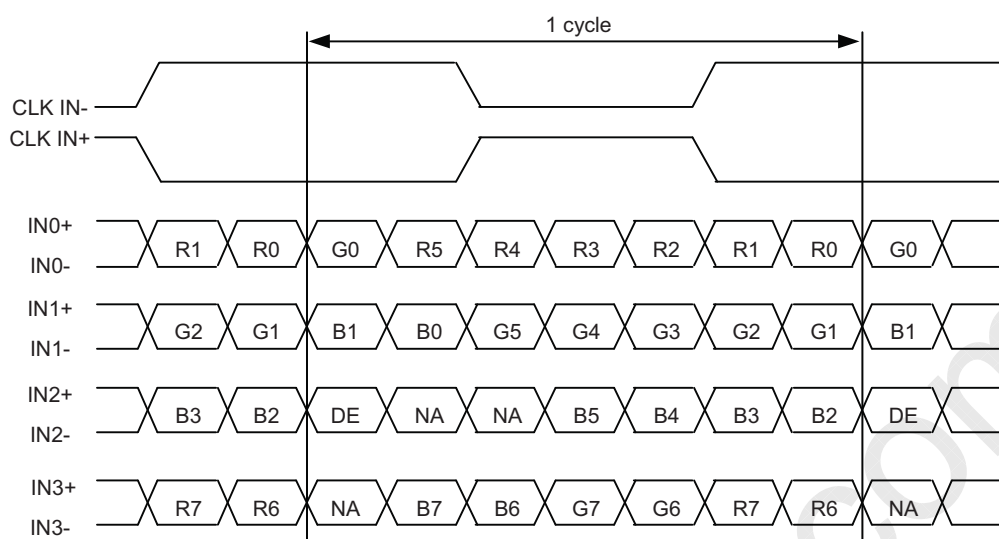

DE : Display Enable

NA : Not Available

< MSL=Low >

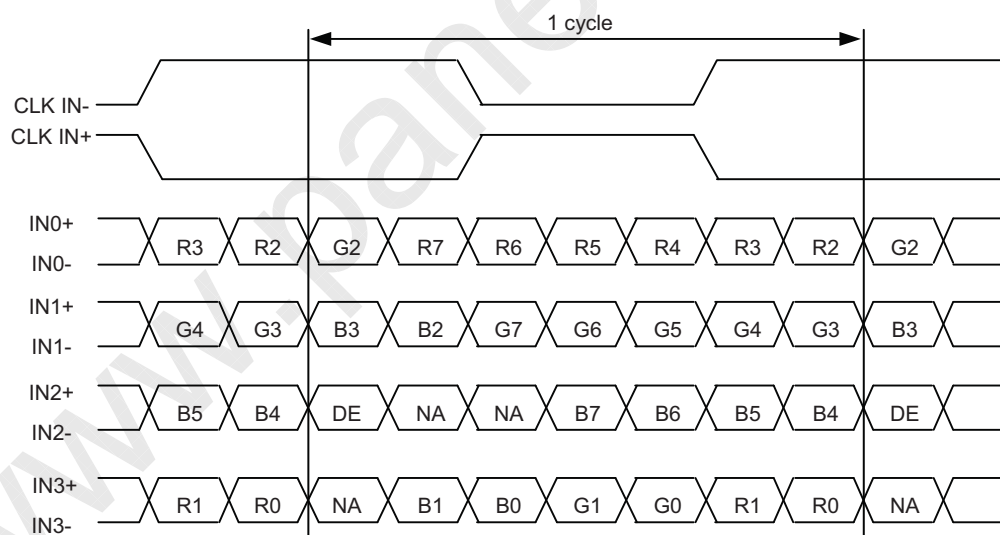

DE : Display Enable

NA : Not Available

2) 6 Bit Mode

Note : Assignment for (THC63LVDM83R)

Transmitter		MSL
Pin No.	Date	= High or Low
51	TA0	R0 (LSB)
52	TA1	R1
54	TA2	R2
55	TA3	R3
56	TA4	R4
3	TA5	R5 (MSB)
4	TA6	G0 (LSB)
6	TB0	G1
7	TB1	G2
11	TB2	G3
12	TB3	G4
14	TB4	G5 (MSB)
15	TB5	B0 (LSB)
19	TB6	B1
20	TC0	B2
22	TC1	B3
23	TC2	B4
24	TC3	B5 (MSB)
27	TC4	(NA)
28	TC5	(NA)
30	TC6	DE
50	TD0	(NA)
2	TD1	(NA)
8	TD2	(NA)
10	TD3	(NA)
16	TD4	(NA)
18	TD5	(NA)
25	TD6	(NA)

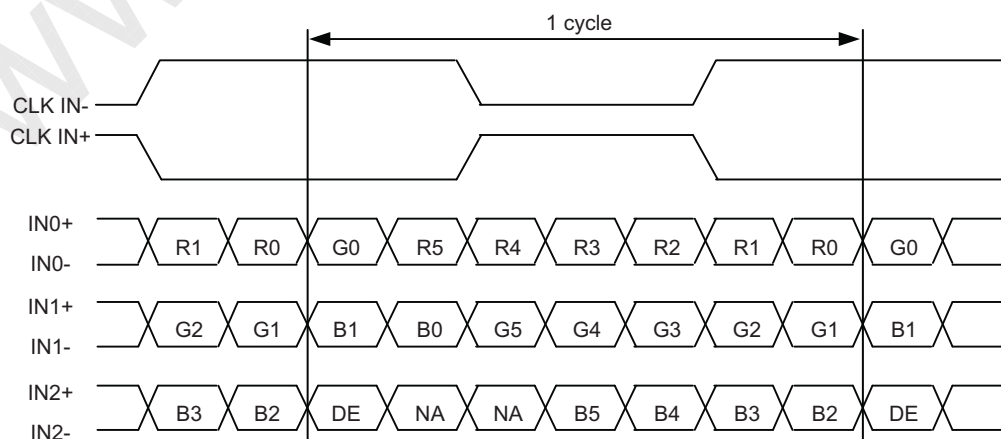

DE : Display Enable

NA : Not Available

* Connection circuit of IN3-, IN3+ for 6 bit mode

① Connect TD0~TD5 to GND

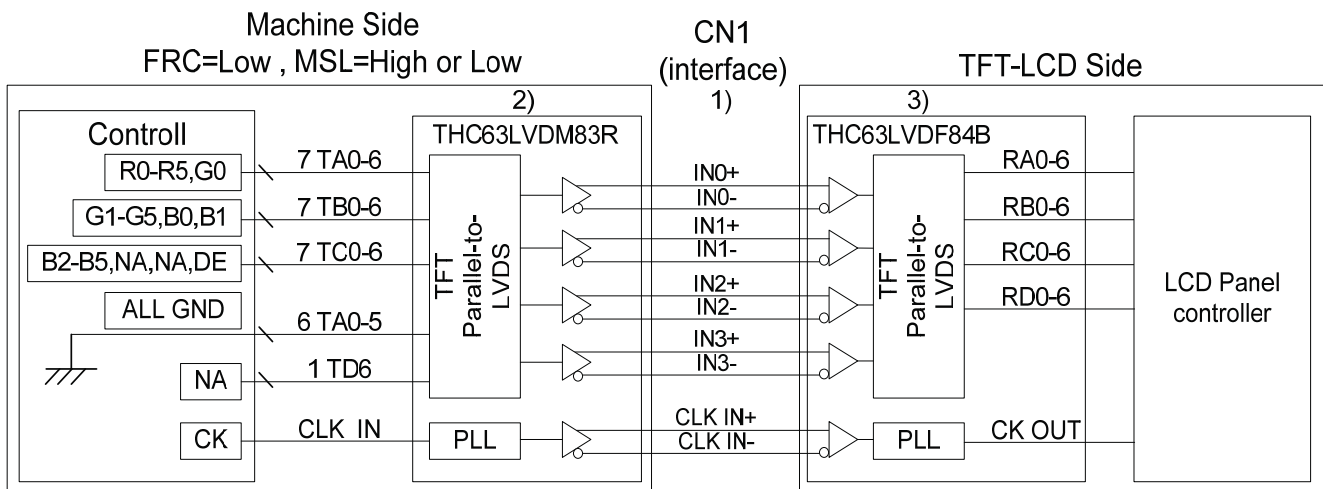

② Connect IN3+ by 3.3V resistor 820Ω and connect IN3- to GND by resistor 470Ω as below circuit.
Never turn on LCD when IN3+ and IN3- are Open.

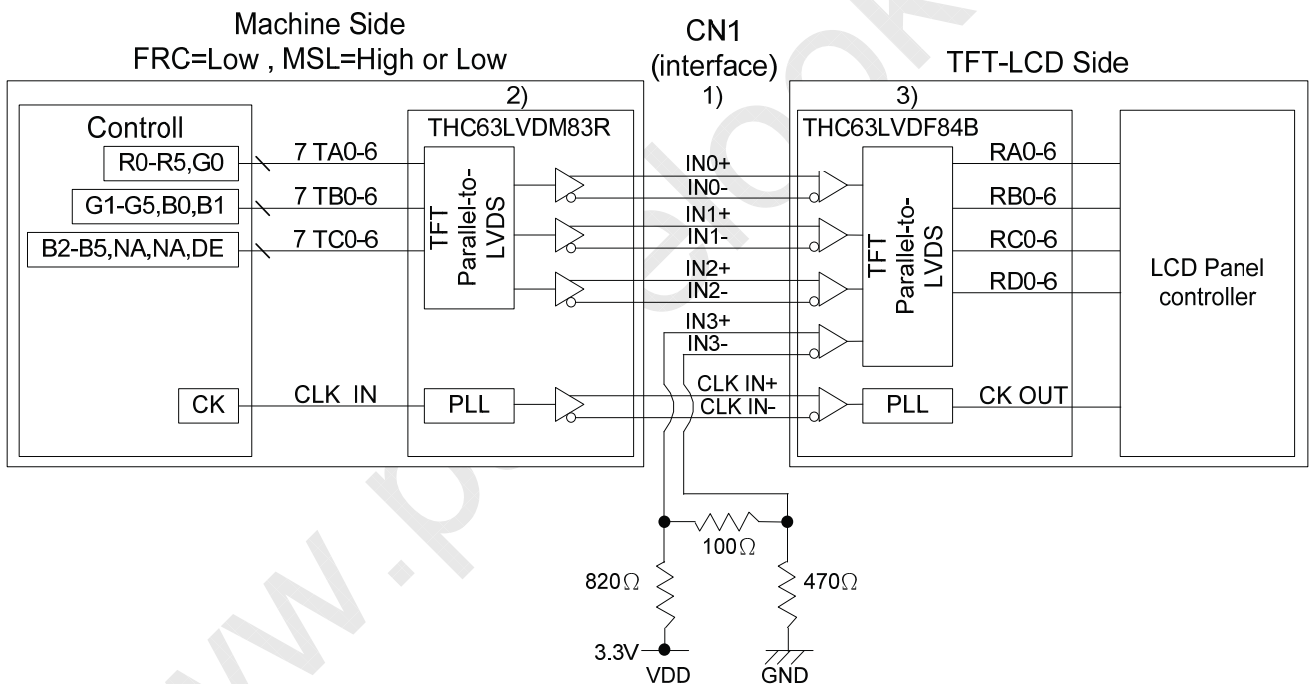

Note 1: The impedance between differential signal pair should be 100 ohms.

Note 2: Transmitter is not contained in module.

The recommended transmitter is Thine THC63LVDM83R or equivalent.

Note 3: Receiver is built in the module.

9.4 INTERFACE TIMING

(1) LVDS receiver timing

(Interface of TFT module)

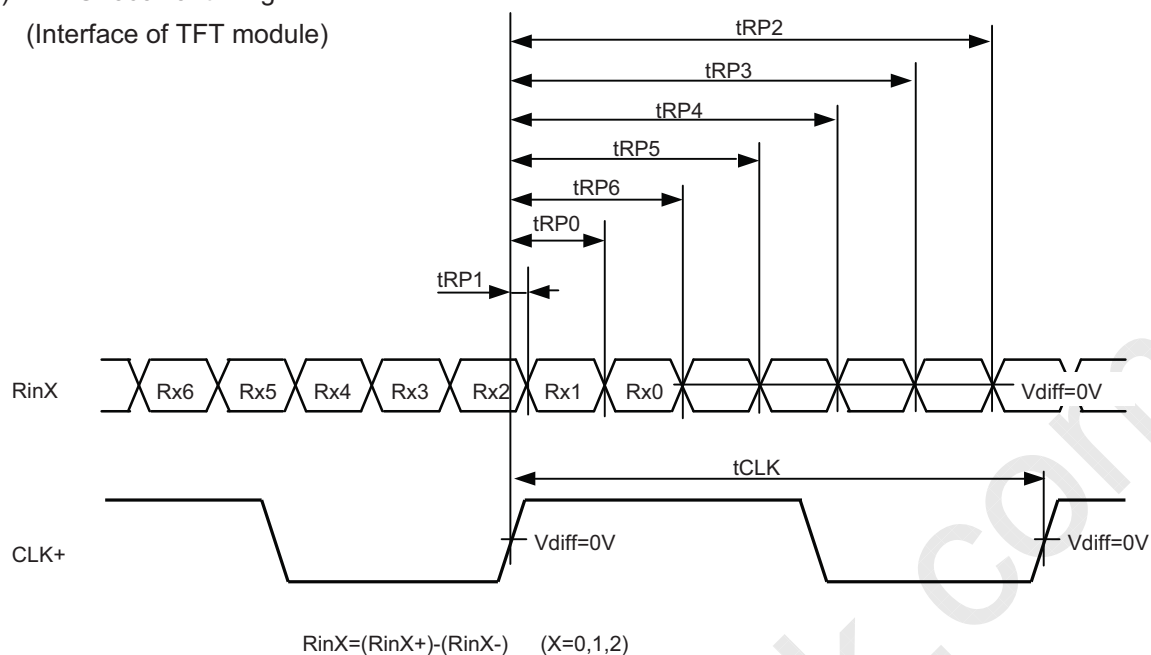

	Item	Symbol	Min.	Typ.	Max.	Unit	Note
DCLK	FREQUENCY	$1/t_{CLK}$	35	40	45	MHz	
$RinX$ ($X=0,1,2$)	0 data position	t_{RP0}	$1/7t_{CLK}-0.49$	$1/7*t_{CLK}$	$1/7t_{CLK}+0.49$	ns	
	1st data position	t_{RP1}	-0.49	0	+0.49		
	2nd data position	t_{RP2}	$6/7t_{CLK}-0.49$	$6/7*t_{CLK}$	$6/7t_{CLK}+0.49$		
	3rd data position	t_{RP3}	$5/7t_{CLK}-0.49$	$5/7*t_{CLK}$	$5/7t_{CLK}+0.49$		
	4th data position	t_{RP4}	$4/7t_{CLK}-0.49$	$4/7*t_{CLK}$	$4/7t_{CLK}+0.49$		
	5th data position	t_{RP5}	$3/7t_{CLK}-0.49$	$3/7*t_{CLK}$	$3/7t_{CLK}+0.49$		
	6th data position	t_{RP6}	$2/7t_{CLK}-0.49$	$2/7*t_{CLK}$	$2/7t_{CLK}+0.49$		

(2) Converter timing

(Timing chart for transmitter)

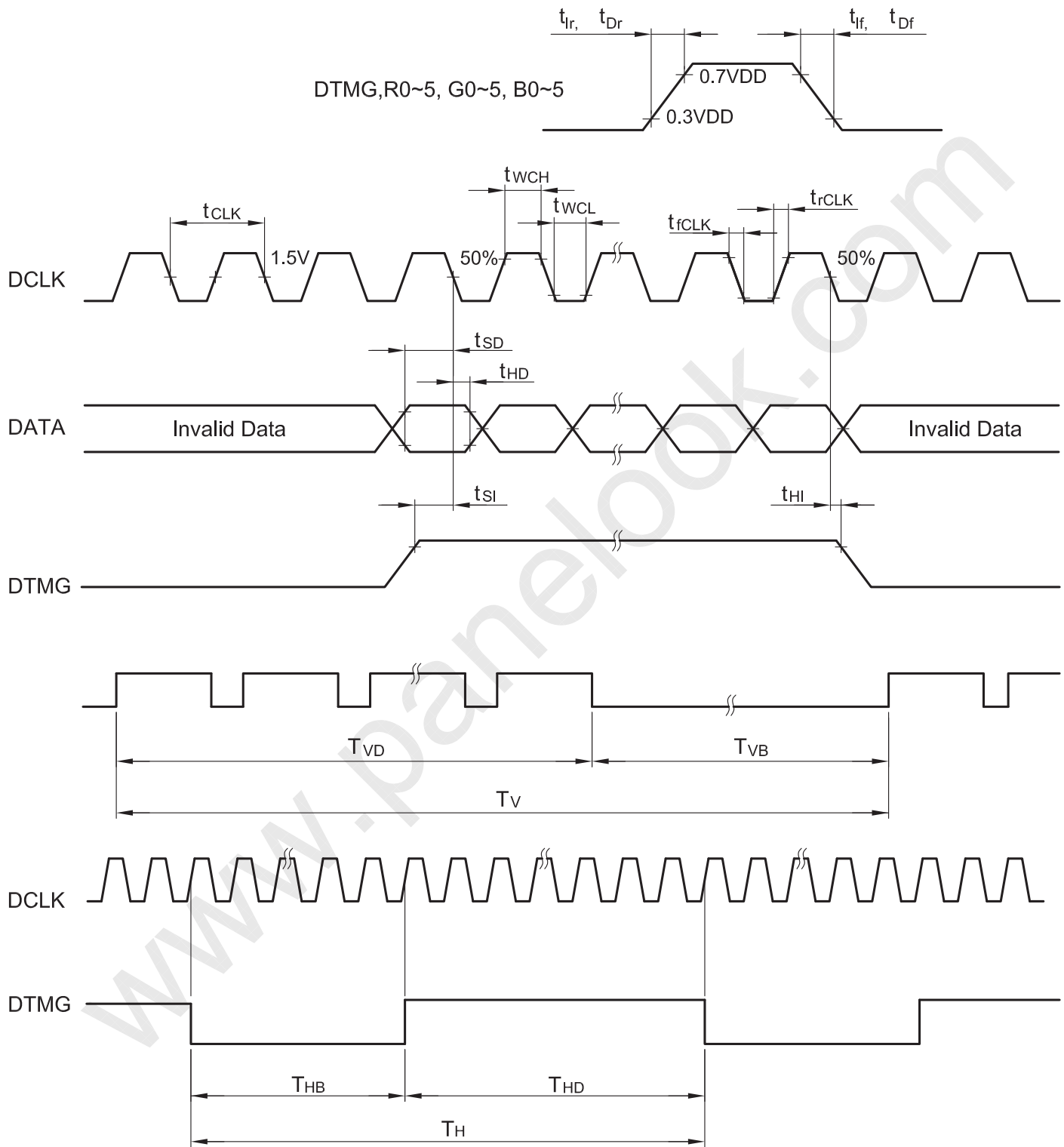

Data is latched by falling edge triggered DCLK

	Item	Symbol	Min.	Typ.	Max.	Unit
DCLK	Cycle time	t_{CLK}	22	25	28	ns
	Low level Width	t_{WCL}	12	-	-	
	High level Width	t_{WCH}	12	-	-	
	Rise time	t_{rCLK}	-	-	5	
	Fall time	t_{fCLK}	-	-	5	
	Duty	D	0.45	0.5	0.55	-
DTMG	Set up time	t_{SI}	5	-	-	ns
	Hold time	t_{HI}	10	-	-	ns
	Rise/Fall time	t_{r}, t_{f}	-	-	5	ns
	Horizontal Cycle	T_H	-	1060	-	tclk
	Horizontal Valid Data width	T_{HD}	-	800	-	
	Horizontal porch width	T_{HB}	-	260	-	
	Vertical Cycle	T_V	-	628	-	TH
	Vertical Valid Data width	T_{VD}	-	600	-	
Vertical porch width	T_{VB}	-	28	-		
DATA	Set up time	t_{SD}	5	-	-	ns
	Hold time	t_{HD}	10	-	-	ns
	Rise/Fall time	t_{Dr}, t_{Df}	-	-	5	ns

www.panelook.com

9.5 POWER SEQUENCE

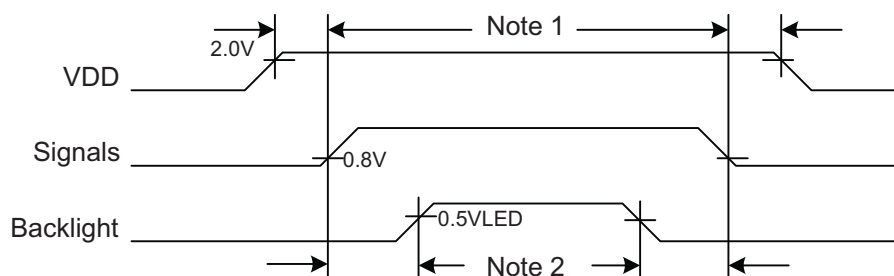

Note 1: In order to avoid any damages, VDD has to be applied before all other signals. The opposite is true for power Off where VDD has to be remained on until all other signals have been switch off. The recommended time period is 1 second. Hot plugging might cause display damage due to incorrect power sequence, please pay attention on interface connecting before power on.

Note 2: In order to avoid showing uncompleted patterns in transient state. It is recommended that switching the backlight on is delayed for 1 second after the signals have been applied. The opposite is true for power Off where the backlight has to be switched off 1 second before the signals are removed.

9.6 RELATIONSHIP BETWEEN DISPLAYED COLORS AND INPUT DATA

1) 8 Bit Mode

color		Red Data								Green Data								Blue Data									
		Input		R7	R6	R5	R4	R3	R2	R1	R0	G7	G6	G5	G4	G3	G2	G1	G0	B7	B6	B5	B4	B3	B2	B1	B0
		MSB				LSB				MSB				LSB				MSB				LSB					
Basic Color	Black	0	0	0	0	0	0	0	0	0	0	0	0	0	0	0	0	0	0	0	0	0	0	0	0	0	
	Red (0)	1	1	1	1	1	1	0	0	0	0	0	0	0	0	0	0	0	0	0	0	0	0	0	0	0	
	Green (0)	0	0	0	0	0	0	1	1	1	1	1	1	0	0	0	0	0	0	0	0	0	0	0	0	0	
	Blue (0)	0	0	0	0	0	0	0	0	0	0	0	0	1	1	1	1	1	1	1	1	1	1	1	1	1	
	Cyan	0	0	0	0	0	0	1	1	1	1	1	1	1	1	1	1	1	1	1	1	1	1	1	1	1	
	Magenta	1	1	1	1	1	1	0	0	0	0	0	0	1	1	1	1	1	1	1	1	1	1	1	1	1	
	Yellow	1	1	1	1	1	1	1	1	1	1	1	1	0	0	0	0	0	0	0	0	0	0	0	0	0	
	White	1	1	1	1	1	1	1	1	1	1	1	1	1	1	1	1	1	1	1	1	1	1	1	1	1	
Red	Black	0	0	0	0	0	0	0	0	0	0	0	0	0	0	0	0	0	0	0	0	0	0	0	0	0	
	Red (62)	0	0	0	0	0	1	0	0	0	0	0	0	0	0	0	0	0	0	0	0	0	0	0	0	0	
	Red (61)	0	0	0	0	1	0	0	0	0	0	0	0	0	0	0	0	0	0	0	0	0	0	0	0	0	
	:	:	:	:	:	:	:	:	:	:	:	:	:	:	:	:	:	:	:	:	:	:	:	:	:	:	
	:	:	:	:	:	:	:	:	:	:	:	:	:	:	:	:	:	:	:	:	:	:	:	:	:	:	
	Red (1)	1	1	1	1	1	0	0	0	0	0	0	0	0	0	0	0	0	0	0	0	0	0	0	0	0	
	Red (0)	1	1	1	1	1	1	0	0	0	0	0	0	0	0	0	0	0	0	0	0	0	0	0	0	0	
Green	Black	0	0	0	0	0	0	0	0	0	0	0	0	0	0	0	0	0	0	0	0	0	0	0	0	0	
	Green (62)	0	0	0	0	0	0	0	0	0	0	0	1	0	0	0	0	0	0	0	0	0	0	0	0	0	
	Green (61)	0	0	0	0	0	0	0	0	0	0	1	0	0	0	0	0	0	0	0	0	0	0	0	0	0	
	:	:	:	:	:	:	:	:	:	:	:	:	:	:	:	:	:	:	:	:	:	:	:	:	:	:	
	:	:	:	:	:	:	:	:	:	:	:	:	:	:	:	:	:	:	:	:	:	:	:	:	:	:	
	Green (253)	0	0	0	0	0	0	1	1	1	1	1	0	0	0	0	0	0	0	0	0	0	0	0	0	0	
	Green (2540)	0	0	0	0	0	0	1	1	1	1	1	1	0	0	0	0	0	0	0	0	0	0	0	0	0	
Blue	Black	0	0	0	0	0	0	0	0	0	0	0	0	0	0	0	0	0	0	0	0	0	0	0	0	0	
	Blue (1)	0	0	0	0	0	0	0	0	0	0	0	0	0	0	0	0	0	0	1	0	0	0	0	0	1	
	Blue (2)	0	0	0	0	0	0	0	0	0	0	0	0	0	0	0	0	0	1	0	0	0	0	0	1	0	
	:	:	:	:	:	:	:	:	:	:	:	:	:	:	:	:	:	:	:	:	:	:	:	:	:	:	
	:	:	:	:	:	:	:	:	:	:	:	:	:	:	:	:	:	:	:	:	:	:	:	:	:	:	
	Blue (253)	0	0	0	0	0	0	0	0	0	0	0	0	1	1	1	1	1	0	1	1	1	1	1	1	0	
	Blue (254)	0	0	0	0	0	0	0	0	0	0	0	0	1	1	1	1	1	1	0	1	1	1	1	1	0	
	Blue (255)	0	0	0	0	0	0	0	0	0	0	0	0	1	1	1	1	1	1	1	1	1	1	1	1	1	

Note 1: Definition of gray scale :

Color(n)----Number in parenthesis indicates gray scale level.

Larger number corresponds to brighter level.

Note 2: Data signal : 1:High, 0 : Low

2) 6 Bit Mode

Color	Input	Red Data						Green Data						Blue Data					
		R5	R4	R3	R2	R1	R0	G5	G4	G3	G2	G1	G0	B5	B4	B3	B2	B1	B0
		MSB			LSB			MSB			LSB			MSB			LSB		
Basic Color	Black	0	0	0	0	0	0	0	0	0	0	0	0	0	0	0	0	0	0
	Red (63)	1	1	1	1	1	1	0	0	0	0	0	0	0	0	0	0	0	0
	Green (63)	0	0	0	0	0	0	1	1	1	1	1	1	0	0	0	0	0	0
	Blue (63)	0	0	0	0	0	0	0	0	0	0	0	0	1	1	1	1	1	1
	Cyan	0	0	0	0	0	0	1	1	1	1	1	1	1	1	1	1	1	1
	Magenta	1	1	1	1	1	1	0	0	0	0	0	0	1	1	1	1	1	1
	Yellow	1	1	1	1	1	1	1	1	1	1	1	1	0	0	0	0	0	0
	White	1	1	1	1	1	1	1	1	1	1	1	1	1	1	1	1	1	1
Red	Black	0	0	0	0	0	0	0	0	0	0	0	0	0	0	0	0	0	0
	Red (1)	0	0	0	0	0	1	0	0	0	0	0	0	0	0	0	0	0	0
	Red (2)	0	0	0	0	1	0	0	0	0	0	0	0	0	0	0	0	0	0
	:	:	:	:	:	:	:	:	:	:	:	:	:	:	:	:	:	:	:
	:	:	:	:	:	:	:	:	:	:	:	:	:	:	:	:	:	:	:
	Red (61)	1	1	1	1	0	1	0	0	0	0	0	0	0	0	0	0	0	0
	Red (62)	1	1	1	1	1	0	0	0	0	0	0	0	0	0	0	0	0	0
	Red (63)	1	1	1	1	1	1	0	0	0	0	0	0	0	0	0	0	0	0
Green	Black	0	0	0	0	0	0	0	0	0	0	0	0	0	0	0	0	0	0
	Green (1)	0	0	0	0	0	0	0	0	0	0	1	0	0	0	0	0	0	0
	Green (2)	0	0	0	0	0	0	0	0	0	1	0	0	0	0	0	0	0	0
	:	:	:	:	:	:	:	:	:	:	:	:	:	:	:	:	:	:	:
	:	:	:	:	:	:	:	:	:	:	:	:	:	:	:	:	:	:	:
	Green (61)	0	0	0	0	0	0	1	1	1	1	0	1	0	0	0	0	0	0
	Green (62)	0	0	0	0	0	0	1	1	1	1	1	0	0	0	0	0	0	0
	Green (63)	0	0	0	0	0	0	1	1	1	1	1	1	0	0	0	0	0	0
Blue	Black	0	0	0	0	0	0	0	0	0	0	0	0	0	0	0	0	0	0
	Blue (1)	0	0	0	0	0	0	0	0	0	0	0	0	0	0	0	0	0	1
	Blue (2)	0	0	0	0	0	0	0	0	0	0	0	0	0	0	0	0	1	0
	:	:	:	:	:	:	:	:	:	:	:	:	:	:	:	:	:	:	:
	:	:	:	:	:	:	:	:	:	:	:	:	:	:	:	:	:	:	:
	Blue (61)	0	0	0	0	0	0	0	0	0	0	0	0	1	1	1	1	0	1
	Blue (62)	0	0	0	0	0	0	0	0	0	0	0	0	1	1	1	1	1	0
	Blue (63)	0	0	0	0	0	0	0	0	0	0	0	0	1	1	1	1	1	1

Notes 1: Definition of gray scale :

Color(n)---Number in parenthesis indicates gray scale level.

Larger number corresponds to brighter

Note 2: Data Signal : 1; High, 0 : Low

10. OUTLINE DIMENSIONS
10.1 SURFACE SIDE

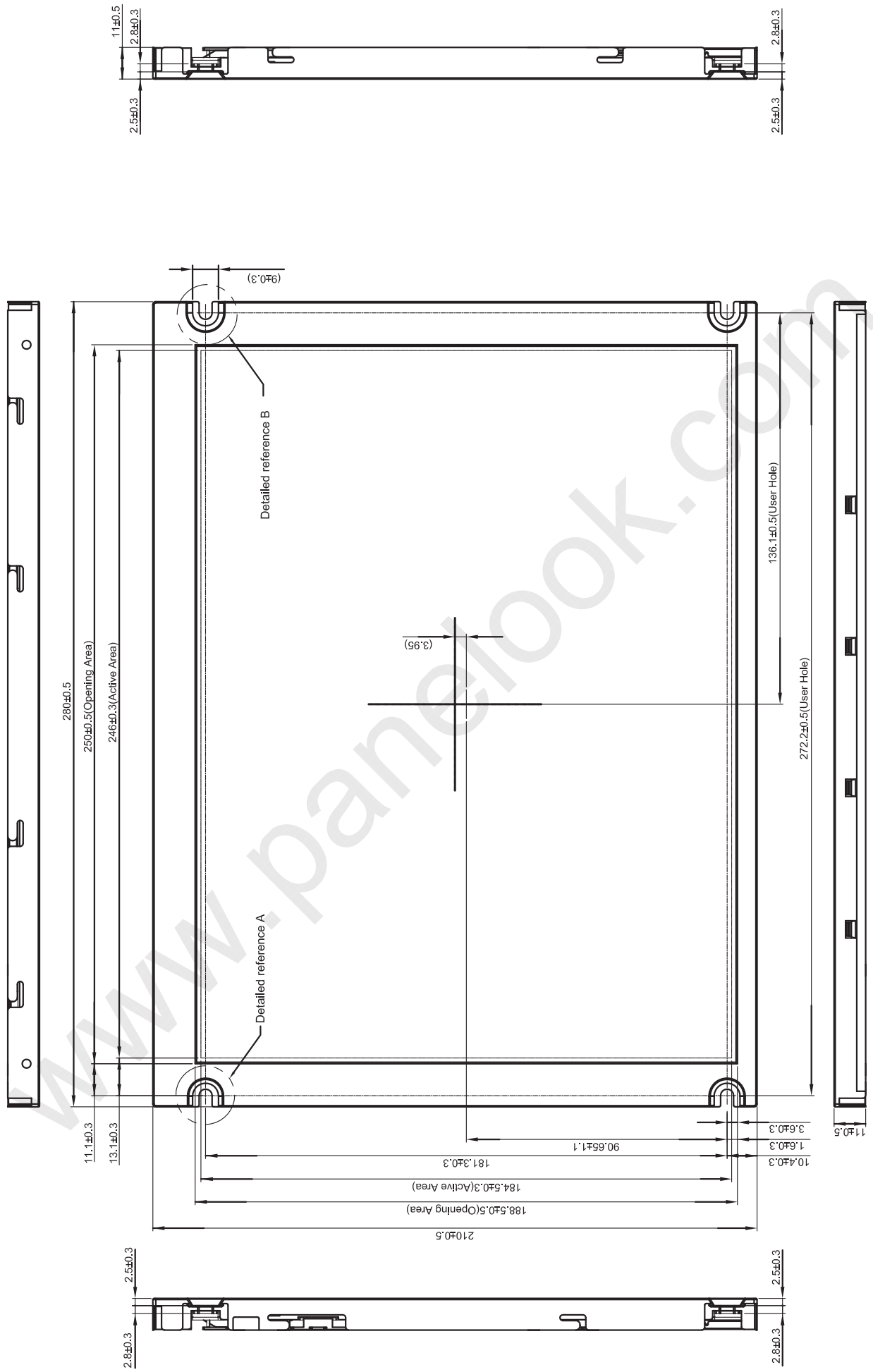

Scale : NTS
Unit : mm

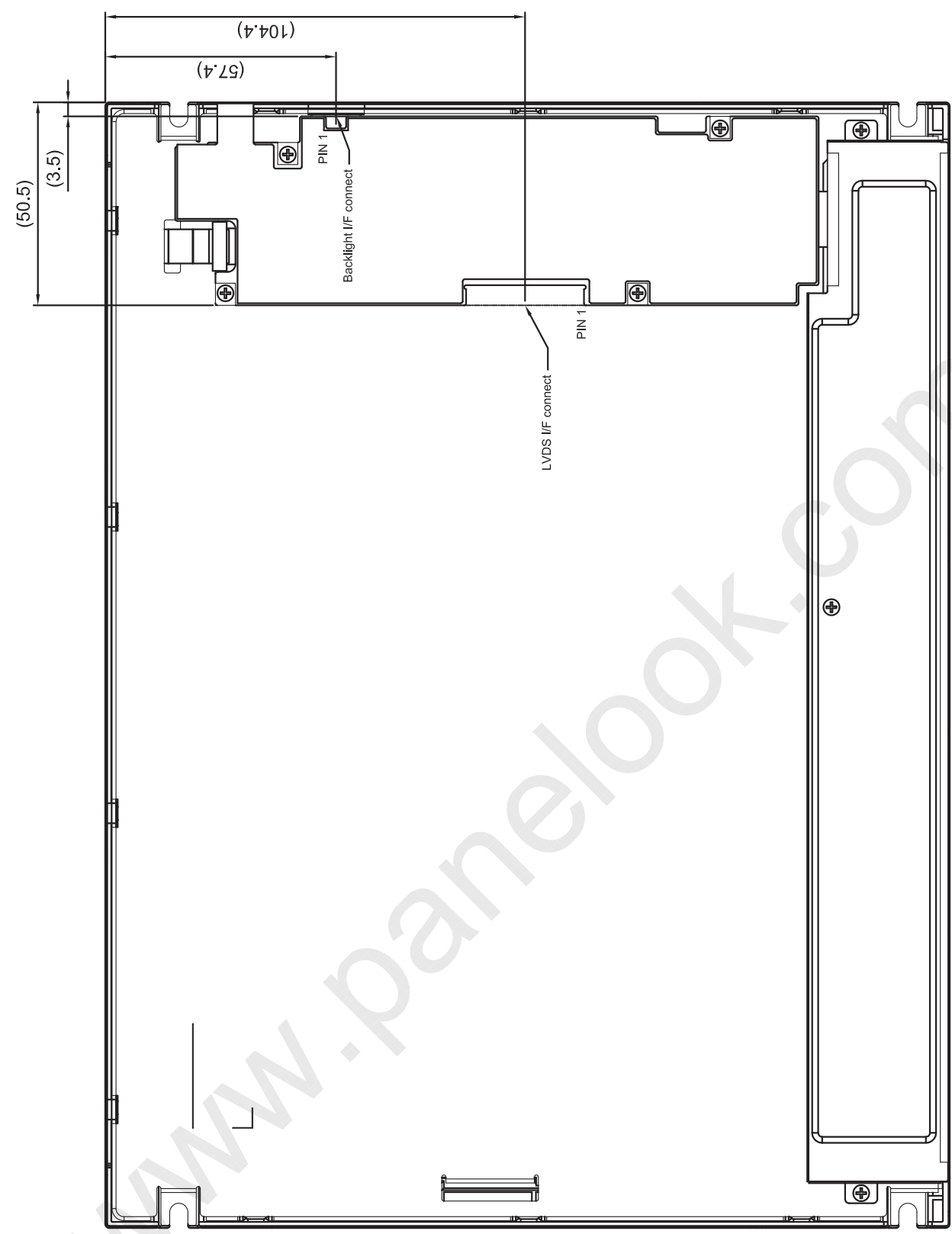

Scale : NTS
Unit : mm

10.2 BACK SIDE

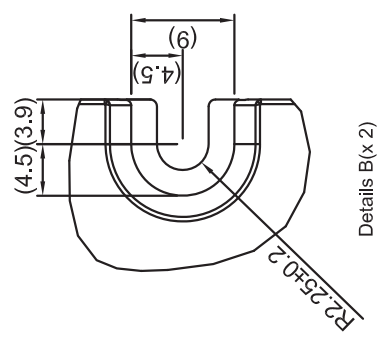
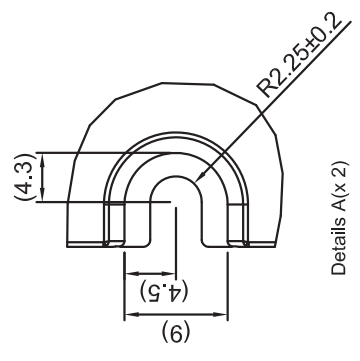

7B63PS 2710-TX31D36VM2EAA-1	SHEET No.	PAGE	10-2/2
-----------------------------	-----------	------	--------

KAOSIUNG HITACHI
ELECTRONICS CO.,LTD.

11. APPEARANCE STANDARD

The appearance inspection is performed in a dark room around 500~1000 lx based on the conditions as below:

- The distance between inspector's eyes and display is 30 cm.
- The viewing zone is defined with angle θ shown in Fig. 11.1 The inspection should be performed within 45° when display is shut down. The inspection should be performed within 5° when display is power on.

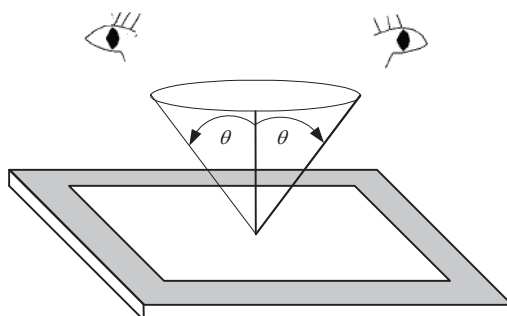

Fig. 11.1

11.1 THE DEFINITION OF LCD ZONE

LCD panel is divided into 3 areas as shown in Fig.11.2 for appearance specification in next section. A zone is the LCD active area (dot area); B zone is the area, which extended 1 mm out from LCD active area; C zone is the area between B zone and metal frame.

In terms of housing design, B zone is the recommended window area customers' housing should be located in.

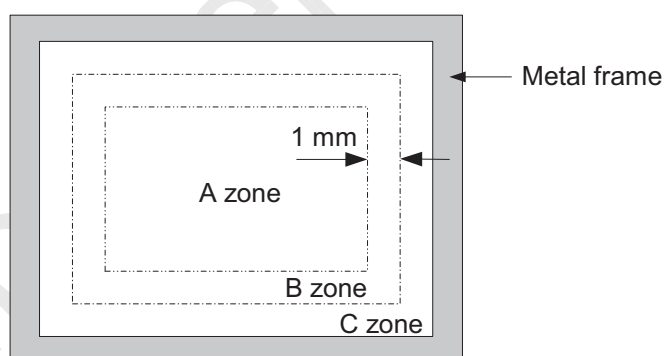

Fig. 11.2

11.2 LCD APPEARANCE SPECIFICATION

The specification as below is defined as the amount of unexpected phenomenon or material in different zones of LCD panel. The definitions of length, width and average diameter using in the table are shown in Fig. 11.3 and Fig. 11.4.

Item	Criteria				Applied zone
	Length (mm)	Width (mm)	Maximum number	Minimum space	
Scratches on polarizer	Ignored	$W \leq 0.02$	Ignored	-	A
	$L \leq 40$	$W \leq 0.02$	10	-	
	$L \leq 20$	$W \leq 0.04$	10	-	
Dent	Serious one is not allowed				A
Wrinkles in polarizer	Serious one is not allowed				A
Bubbles on polarizer	Average diameter (mm)		Maximum number		A
	$D \leq 0.3$		Ignored		
	$0.3 < D \leq 0.5$		12		
	$0.5 < D \leq 1.0$		6		
1) Stains 2) Foreign Materials 3) Dark Spot	Filamentous (Line shape)				A
	Length (mm)	Width (mm)	Maximum number		
	-	$W \leq 0.03$	Ignored		
	$L \leq 1.0$	$W \leq 0.06$	12		
	Round (Dot shape)				A
	Average diameter (mm)		Maximum number	Minimum Space	
	$D \leq 0.22$		Ignored	-	
	$0.22 \leq D < 0.45$		6	10 mm	
	$0.45 \leq D < 0.7$		4	30 mm	
	$0.7 \leq D$		None	-	
In total		Filamentous + Round=10			
Those wiped out easily are acceptable					
Dot-Defect (Note 1)	Bright dot-defect	Type	Maximum number		A
		1 dot	4		
		2 adjacent dot	1		
		3 adjacent dot or above	Not allowed		
	In total		5		
	Dark dot-defect	1 dot	5		
		2 adjacent dot	2		
		3 adjacent dot or above	Not allowed		
		In total		5	
	In total		10		

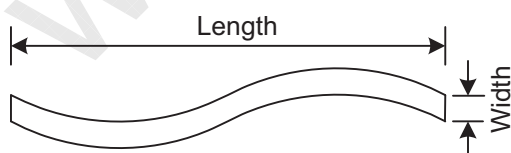
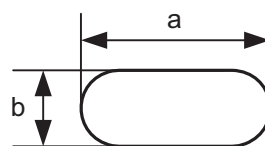

Fig. 11.3



$$\text{Average diameter} = \frac{a+b}{2}$$

Fig. 11.4

Note 1: The definitions of dot defect are as below:

- The defect area of the dot must be bigger than half of a dot.
- For bright dot-defect, showing black pattern, the dot's brightness must be over 30% brighter than others.
- For dark dot-defect, showing white pattern, the dot's brightness must be under 70% darker than others.
- The definition of 1-dot-defect is the defect-dot, which is isolated and no adjacent defect-dot.
- The definition of adjacent dot is shown as Fig. 11.5.

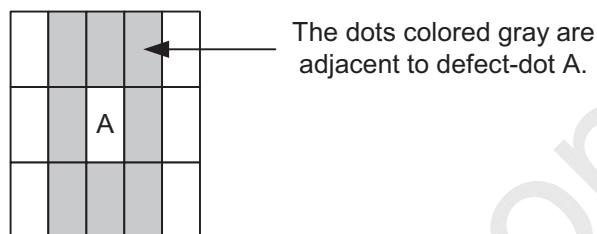

Fig. 11.5

12. PRECAUTIONS

12.1 PRECAUTIONS of ESD

- 1) Before handling the display, please ensure your body has been connected to ground to avoid any damages by ESD. Also, do not touch display's interface directly when assembling.
- 2) Please remove the protection film very slowly before turning on the display to avoid generating ESD.

12.2 PRECAUTIONS of HANDLING

- 1) In order to keep the appearance of display in good condition, please do not rub any surfaces of the displays by using sharp tools harder than 3H, especially touch panel, metal frame and polarizer.
- 2) Please do not stack the displays as this may damage the surface. In order to avoid any injuries, please avoid touching the edge of the glass or metal frame and wore gloves during handling.
- 3) Touching the polarizer or terminal pins with bare hand should be avoided to prevent staining and poor electrical contact.
- 4) Do not use any harmful chemicals such as acetone, toluene, and isopropyl alcohol to clean display's surfaces.
- 5) Please use soft cloth or absorbent cotton with ethanol to clean the display by gently wiping. Moreover, when wiping the display, please wipe it by horizontal or vertical direction instead of circling to prevent leaving scars on the display's surface, especially polarizer.
- 6) Please wipe any unknown liquids immediately such as saliva, water or dew on the display to avoid color fading or any permanent damages.
- 7) Maximum pressure to the surface of the display must be less than 1.96×10^4 Pa. If the area of applied pressure is less than 1 cm^2 , the maximum pressure must be less than 1.96N.

12.3 PRECAUTION of MOUNTING

- 1) You must mount Module using mounting holes arranged in 4 corners tightly.
- 2) You should consider the mounting structure so that uneven force (ex. twisted stress) is not applied to Module.

And the case which Module is mounted should have sufficient strength so that external force is not transmitted directly to Module.

- 3) To improve the strength of module against the mechanical shock the space between module and the case should be 0.7mm minimum.

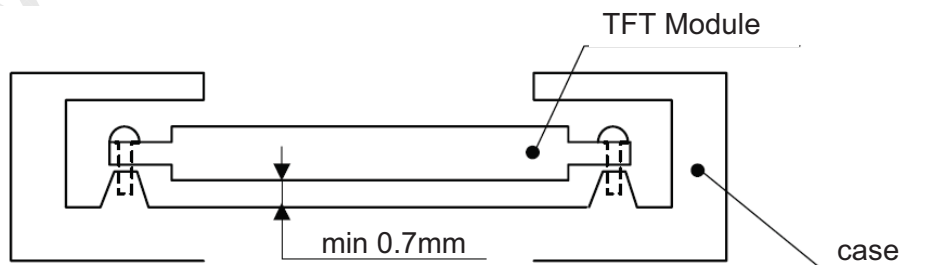

- 4) Heat diffusion must be under consideration when designing unit housing.



12.4 PRECAUTIONS of OPERATING

- 1) Please input signals and voltages to the displays according to the values defined in the section of electrical characteristics to obtain the best performance. Any voltages over than absolute maximum rating will cause permanent damages to this display. Also, any timing of the signals out of this specification would cause unexpected performance.
- 2) When the display is operating at significant low temperature, the response time will be slower than it at 25 C°. In high temperature, the color will be slightly dark and blue compared to original pattern. However, these are temperature-related phenomenon of LCD and it will not cause permanent damages to the display when used within the operating temperature.
- 3) The use of screen saver or sleep mode is recommended when static images are likely for long periods of time. This is to avoid the possibility of image sticking.
- 4) Spike noise can cause malfunction of the circuit. The recommended limitation of spike noise is no bigger than ± 100 mV.

12.5 PRECAUTIONS of STORAGE

If the displays are going to be stored for years, please be aware the following notices.

- 1) Please store the displays in a dark room to avoid any damages from sunlight and other sources of UV light.
- 2) The recommended long term storage temperature is between 10 C° ~35 C° and 55%~75% humidity to avoid causing bubbles between polarizer and LCD glasses, and polarizer peeling from LCD glasses.
- 3) It would be better to keep the displays in the container, which is shipped from Hitachi, and do not unpack it.
- 4) Please do not stick any labels on the display surface for a long time, especially on the polarizer.

13. DESIGNATION of LOT MARK

1) The lot mark is showing in Fig.13.1. First 4 digits are used to represent production lot, T represented made in Taiwan, and the last 6 digits are the serial number.

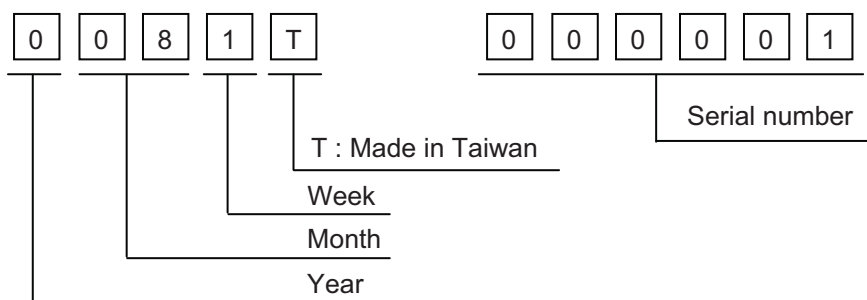

2) The tables as below are showing what the first 4 digits of lot mark are shorted for.

Year	Mark
2010	0
2011	1
2012	2
2013	3
2014	4

Month	Mark	Month	Mark
1	01	7	07
2	02	8	08
3	03	9	09
4	04	10	10
5	05	11	11
6	06	12	12

Week (Days)	Mark
1~7	1
8~14	2
15~21	3
22~28	4
29~31	5

3) Except letters I and O, revision number will be shown on lot mark and following letters A to Z.

4) The location of the lot mark is on the back of the display shown in Fig. 13.1.



Fig. 13.1