



## Features

- Low power consumption
- Low voltage drop
- Low temperature coefficient
- High input voltage (up to 32V)
- Output voltage accuracy: tolerance  $\pm 3\%$
- TO92 and SOT89 package

## Applications

- Battery-powered equipment
- Communication equipment
- Audio/Video equipment

## General Description

The TX71XXH series is a set of three-terminal low power high voltage regulators implemented in CMOS technology. They allow input voltages as high as 32V. They are available with several fixed output voltages ranging from 2.5V to 5.0V. CMOS

technology ensures low voltage drop and low quiescent current. Although designed primarily as fixed voltage regulators, these devices can be used with external components to obtain variable voltages and currents.

## Selection Table

Part No.	Output Voltage	Package	Marking
TX7125Hxx	2.5V	TO92 SOT89	71XX-H#(for TO92) 71XX-1#(for SOT89)
TX7127Hxx	2.7V		
TX7130Hxx	3.0V		
TX7133Hxx	3.3V		
TX7136Hxx	3.6V		
TX7144Hxx	4.4V		
TX7150Hxx	5.0V		

Note: "XX" stands for output voltages.

## Order Information

TX71①②③④⑤

Designator	Symbol	Description
① ②	Integer	Output Voltage(2.1~5.0V)
③	H	Standard
④	T	Package:TO-92
	P	Package:SOT89
⑤	R	RoHS / Pb Free
	G	Halogen Free



### Block Diagram

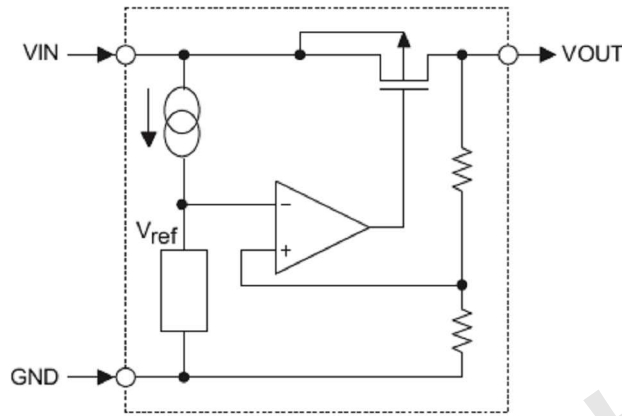

### Pin Assignment

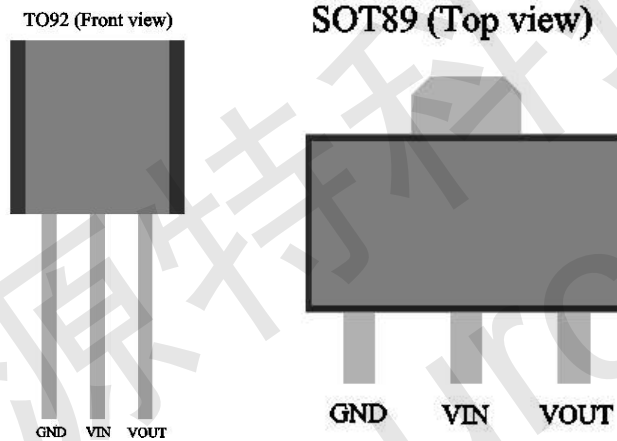

### Absolute Maximum Ratings

Supply Voltage .....-0.3V to 33V      Storage Temperature .....-50°C to 125°C  
Operating Temperature .....-40°C to 85°C

Note: These are stress ratings only. Stresses exceeding the range specified under “Absolute Maximum Ratings” may cause substantial damage to the device. Functional operation of this device at other conditions beyond those listed in the specification is not implied and prolonged exposure to extreme conditions may affect device reliability.

### Thermal Information

Symbol	Parameter	Package	Max.	Unit
$\theta_{JA}$	Thermal Resistance (Junction to Ambient) (Assume no ambient airflow, no heat sink)	TO92	200	°C/W
		SOT89	200	°C/W
$P_D$	Power Dissipation	TO92	0.50	W
		SOT89	0.50	W

Note:  $P_D$  is measured at  $T_a = 25$



## Electrical Characteristics

### TX7125Hxx, +2.5V Output Type

Symbol	Parameter	Test Conditions		Min.	Typ.	Max.	Unit
		V <sub>IN</sub>	Conditions				
V <sub>OUT</sub>	Output Voltage	8V	I <sub>OUT</sub> =10mA	2.425	2.500	2.575	V
I <sub>OUT</sub>	Output Current	8V	-	20	30	-	mA
ΔV <sub>OUT</sub>	Load Regulation	8V	1mA ≤ I <sub>OUT</sub> ≤ 20mA	-	60	100	mV
V <sub>DIF</sub>	Voltage Drop(Note)	-	I <sub>OUT</sub> =1mA, ΔV <sub>OUT</sub> =2%	-	100	-	mV
I <sub>SS</sub>	Current Consumption	8V	No load	-	2.5	5.0	μA
$\frac{V_{OUT}}{V_{IN} - V_{OUT}}$	Line Regulation	-	3.5V ≤ V <sub>IN</sub> ≤ 24V I <sub>OUT</sub> =1mA	-	0.2	-	%/V
V <sub>IN</sub>	Input Voltage	-	-	-	-	32	V
$\frac{V_{OUT}}{T_a}$	Temperature Coefficient	8V	I <sub>OUT</sub> =10mA 0°C < T <sub>a</sub> < 70°C	-	±0.41	-	mV/°C

Note: Dropout voltage is defined as the input voltage minus the output voltage that produces a 2% change in the output voltage from the value at V<sub>IN</sub> = V<sub>OUT</sub>+2V with a fixed load.

### TX7127Hxx +2.7V Output Type

Symbol	Parameter	Test Conditions		Min.	Typ.	Max.	Unit
		V <sub>IN</sub>	Conditions				
V <sub>OUT</sub>	Output Voltage	8V	I <sub>OUT</sub> =10mA	2.619	2.700	2.781	V
I <sub>OUT</sub>	Output Current	8V	-	20	30	-	mA
ΔV <sub>OUT</sub>	Load Regulation	8V	1mA ≤ I <sub>OUT</sub> ≤ 20mA	-	60	100	mV
V <sub>DIF</sub>	Voltage Drop(Note)	-	I <sub>OUT</sub> =1mA, ΔV <sub>OUT</sub> =2%	-	100	-	mV
I <sub>SS</sub>	Current Consumption	8V	No load	-	2.5	5.0	μA
$\frac{V_{OUT}}{V_{IN} - V_{OUT}}$	Line Regulation	-	3.7V ≤ V <sub>IN</sub> ≤ 24V I <sub>OUT</sub> =1mA	-	0.2	-	%/V
V <sub>IN</sub>	Input Voltage	-	-	-	-	32	V
$\frac{V_{OUT}}{T_a}$	Temperature Coefficient	8V	I <sub>OUT</sub> =10mA 0°C < T <sub>a</sub> < 70°C	-	±0.43	-	mV/°C

Note: Dropout voltage is defined as the input voltage minus the output voltage that produces a 2% change in the output voltage from the value at V<sub>IN</sub> = V<sub>OUT</sub>+2V with a fixed load.



**TX7130Hxx, +3.0V Output Type**

Symbol	Parameter	Test Conditions		Min.	Typ.	Max.	Unit
		V <sub>IN</sub>	Conditions				
V <sub>OUT</sub>	Output Voltage	8V	I <sub>OUT</sub> =10mA	2.91	3.00	3.09	V
I <sub>OUT</sub>	Output Current	8V	-	20	30	-	mA
ΔV <sub>OUT</sub>	Load Regulation	8V	1mA ≤ I <sub>OUT</sub> ≤ 20mA	-	60	100	mV
V <sub>DIF</sub>	Voltage Drop(Note)	-	I <sub>OUT</sub> =1mA, ΔV <sub>OUT</sub> =2%	-	100	-	mV
I <sub>SS</sub>	Current Consumption	8V	No load	-	2.5	5.0	μA
$\frac{V_{OUT}}{V_{IN} - V_{OUT}}$	Line Regulation	-	4V ≤ V <sub>IN</sub> ≤ 24V I <sub>OUT</sub> =1mA	-	0.2	-	%/V
V <sub>IN</sub>	Input Voltage	-	-	-	-	32	V
$\frac{V_{OUT}}{T_a}$	Temperature Coefficient	8V	I <sub>OUT</sub> =10mA 0°C < T <sub>a</sub> < 70°C	-	±0.45	-	mV/°C

Note: Dropout voltage is defined as the input voltage minus the output voltage that produces a 2% change in the output voltage from the value at V<sub>IN</sub> = V<sub>OUT</sub>+2V with a fixed load.

**TX7133Hxx, +3.3V Output Type**

Symbol	Parameter	Test Conditions		Min.	Typ.	Max.	Unit
		V <sub>IN</sub>	Conditions				
V <sub>OUT</sub>	Output Voltage	8V	I <sub>OUT</sub> =10mA	3.201	3.300	3.399	V
I <sub>OUT</sub>	Output Current	8V	-	20	30	-	mA
ΔV <sub>OUT</sub>	Load Regulation	8V	1mA ≤ I <sub>OUT</sub> ≤ 20mA	-	60	100	mV
V <sub>DIF</sub>	Voltage Drop(Note)	-	I <sub>OUT</sub> =1mA, ΔV <sub>OUT</sub> =2%	-	100	-	mV
I <sub>SS</sub>	Current Consumption	8V	No load	-	2.5	5.0	μA
$\frac{V_{OUT}}{V_{IN} - V_{OUT}}$	Line Regulation	-	4.5V ≤ V <sub>IN</sub> ≤ 24V I <sub>OUT</sub> =1mA	-	0.2	-	%/V
V <sub>IN</sub>	Input Voltage	-	-	-	-	32	V
$\frac{V_{OUT}}{T_a}$	Temperature Coefficient	8V	I <sub>OUT</sub> =10mA 0°C < T <sub>a</sub> < 70°C	-	±0.5	-	mV/°C

Note: Dropout voltage is defined as the input voltage minus the output voltage that produces a 2% change in the output voltage from the value at V<sub>IN</sub> = V<sub>OUT</sub>+2V with a fixed load.



**TX7136Hxx +3.6V Output type**

Symbol	Parameter	Test Conditions		Min.	Typ.	Max.	Unit
		V <sub>IN</sub>	Conditions				
V <sub>OUT</sub>	Output Voltage	8V	I <sub>OUT</sub> =10mA	3.492	3.600	3.708	V
I <sub>OUT</sub>	Output Current	8V	-	20	30	-	mA
ΔV <sub>OUT</sub>	Load Regulation	8V	1mA ≤ I <sub>OUT</sub> ≤ 20mA	-	60	100	mV
V <sub>DIF</sub>	Voltage Drop(Note)	-	I <sub>OUT</sub> =1mA, ΔV <sub>OUT</sub> =2%	-	100	-	mV
I <sub>SS</sub>	Current Consumption	8V	No load	-	2.5	5.0	μA
$\frac{V_{OUT}}{V_{IN} - V_{OUT}}$	Line Regulation	-	4.6V ≤ V <sub>IN</sub> ≤ 24V I <sub>OUT</sub> =1mA	-	0.2	-	%/V
V <sub>IN</sub>	Input Voltage	-	-	-	-	32	V
$\frac{V_{OUT}}{T_a}$	Temperature Coefficient	8V	I <sub>OUT</sub> =10mA 0°C < T <sub>a</sub> < 70°C	-	±0.6	-	mV/°C

Note: Dropout voltage is defined as the input voltage minus the output voltage that produces a 2% change in the output voltage from the value at V<sub>IN</sub> = V<sub>OUT</sub>+2V with a fixed load.

**TX7144Hxx +4.4V Output type**

Symbol	Parameter	Test Conditions		Min.	Typ.	Max.	Unit
		V <sub>IN</sub>	Conditions				
V <sub>OUT</sub>	Output Voltage	8V	I <sub>OUT</sub> =10mA	4.268	4.400	4.532	V
I <sub>OUT</sub>	Output Current	8V	-	20	30	-	mA
ΔV <sub>OUT</sub>	Load Regulation	8V	1mA ≤ I <sub>OUT</sub> ≤ 20mA	-	60	100	mV
V <sub>DIF</sub>	Voltage Drop(Note)	-	I <sub>OUT</sub> =1mA, ΔV <sub>OUT</sub> =2%	-	100	-	mV
I <sub>SS</sub>	Current Consumption	8V	No load	-	2.5	5.0	μA
$\frac{V_{OUT}}{V_{IN} - V_{OUT}}$	Line Regulation	-	5.4V ≤ V <sub>IN</sub> ≤ 24V I <sub>OUT</sub> =1mA	-	0.2	-	%/V
V <sub>IN</sub>	Input Voltage	-	-	-	-	32	V
$\frac{V_{OUT}}{T_a}$	Temperature Coefficient	8V	I <sub>OUT</sub> =10mA 0°C < T <sub>a</sub> < 70°C	-	±0.7	-	mV/°C

Note: Dropout voltage is defined as the input voltage minus the output voltage that produces a 2% change in the output voltage from the value at V<sub>IN</sub> = V<sub>OUT</sub>+2V with a fixed load.



**TX7150Hxx +5.0V Output Typ. 5.0V**

Symbol	Parameter	Test Conditions		Min.	Typ.	Max.	Unit
		V <sub>IN</sub>	Conditions				
V <sub>OUT</sub>	Output Voltage	8V	I <sub>OUT</sub> =10mA	4.85	5.00	5.15	V
I <sub>OUT</sub>	Output Current	8V	-	20	30	-	mA
ΔV <sub>OUT</sub>	Load Regulation	8V	1mA ≤ I <sub>OUT</sub> ≤ 20mA	-	60	100	mV
V <sub>DIF</sub>	Voltage Drop(Note)	-	I <sub>OUT</sub> =1mA, ΔV <sub>OUT</sub> =2%	-	100	-	mV
I <sub>SS</sub>	Current Consumption	8V	No load	-	2.5	5.0	μA
$\frac{V_{OUT}}{V_{IN} - V_{OUT}}$	Line Regulation	-	6V ≤ V <sub>IN</sub> ≤ 24V I <sub>OUT</sub> =1mA	-	0.2	-	%/V
V <sub>IN</sub>	Input Voltage	-	-	-	-	32	V
$\frac{V_{OUT}}{T_a}$	Temperature Coefficient	8V	I <sub>OUT</sub> =10mA 0°C < T <sub>a</sub> < 70°C	-	±0.75	-	mV/°C

Note: Dropout voltage is defined as the input voltage minus the output voltage that produces a 2% change in the output voltage from the value at V<sub>IN</sub> = V<sub>OUT</sub>+2V with a fixed load.





## Typical Performance Characteristics

### (1) Output Voltage vs Input voltage

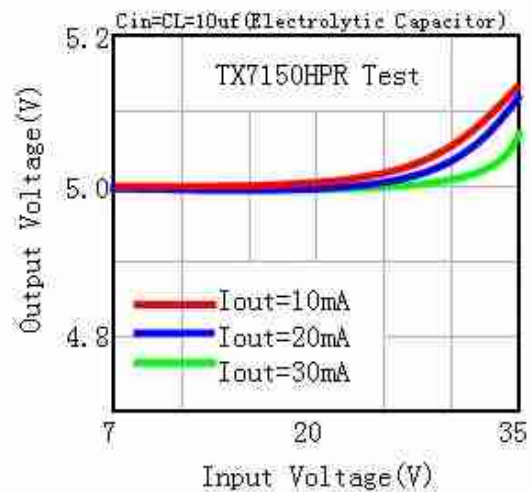
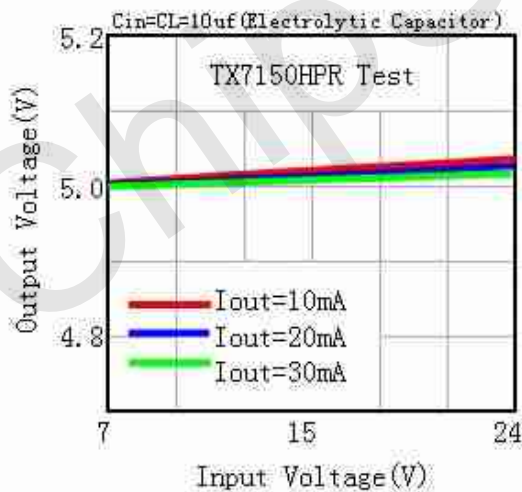
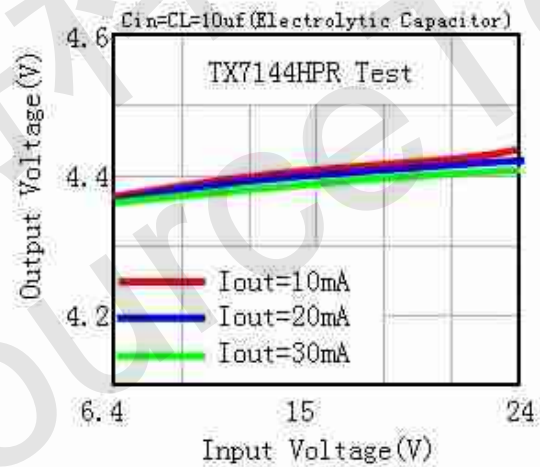
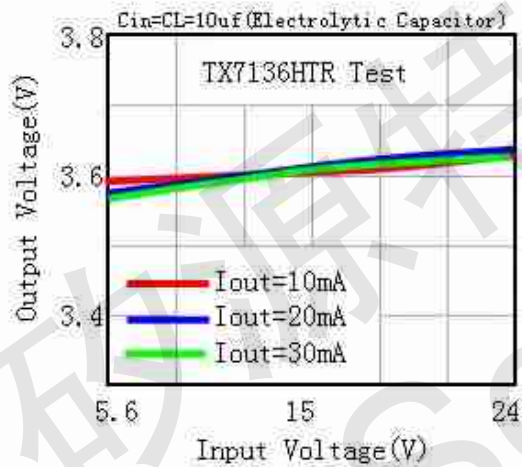
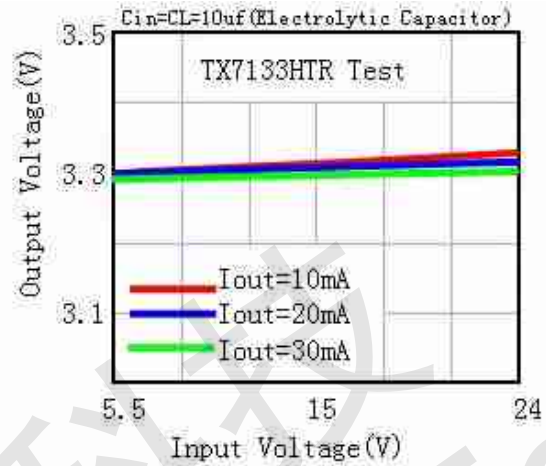
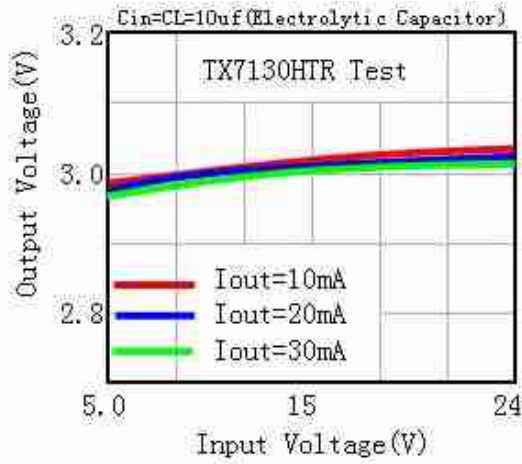



(2) Output Voltage vs. Output Current

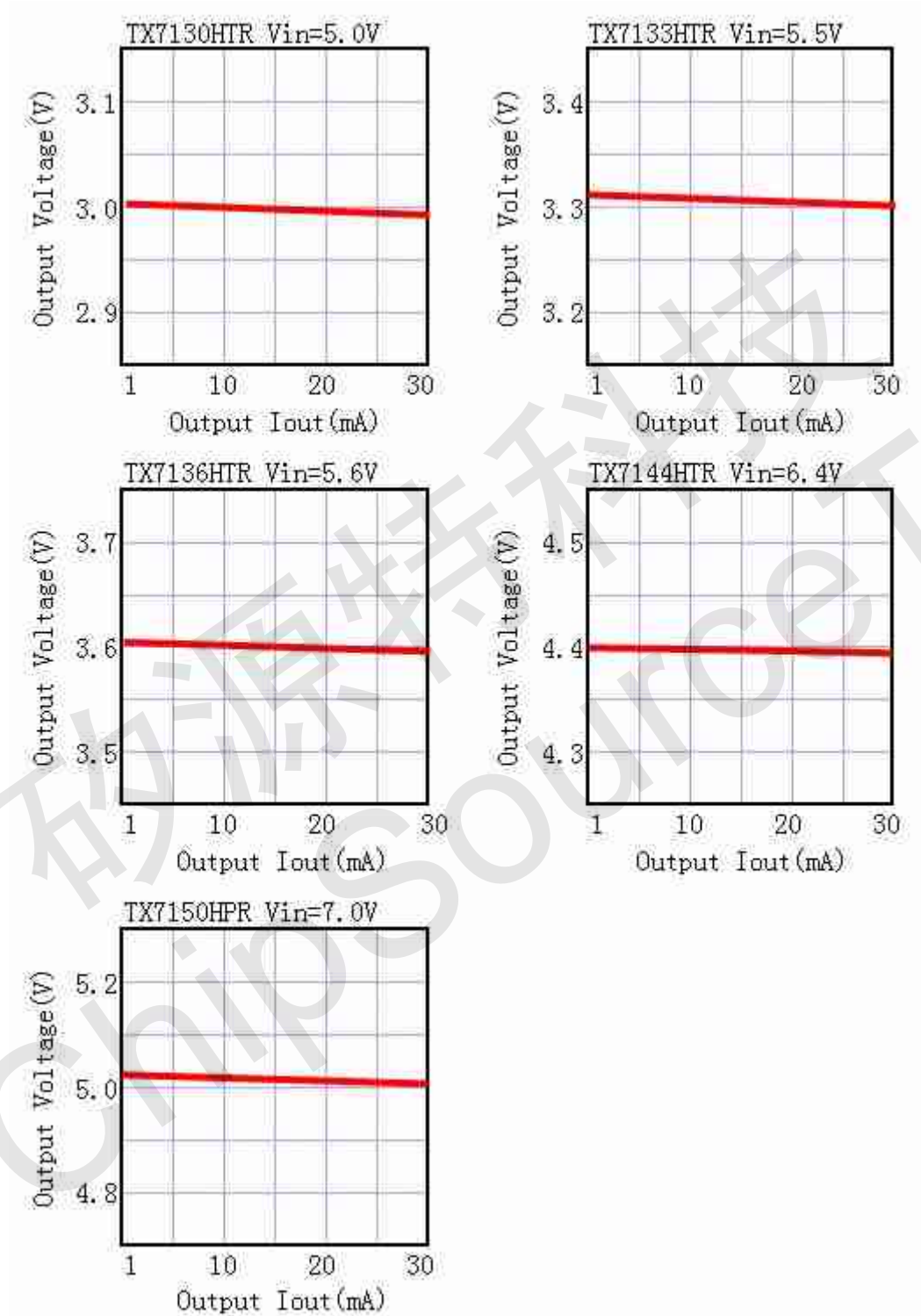





(3) Input Transient Response

TX7133HTR I<sub>out</sub>=10mA CL=10uF

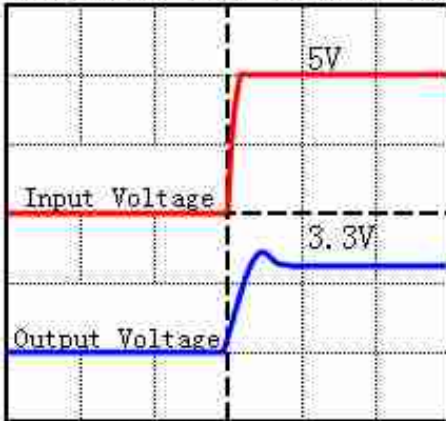

Time (5ms/div)

TX7133HTR I<sub>out</sub>=20mA CL=10uF

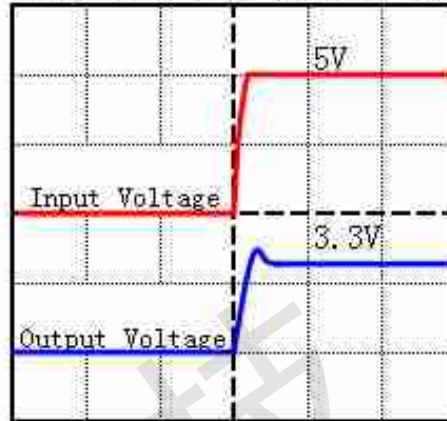

Time (5ms/div)

TX7136HTR I<sub>out</sub>=10mA CL=10uF

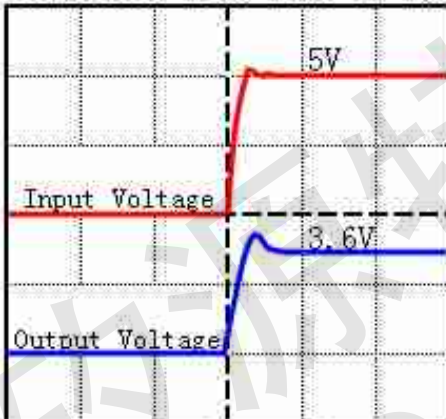

Time (5ms/div)

TX7136HTR I<sub>out</sub>=20mA CL=10uF

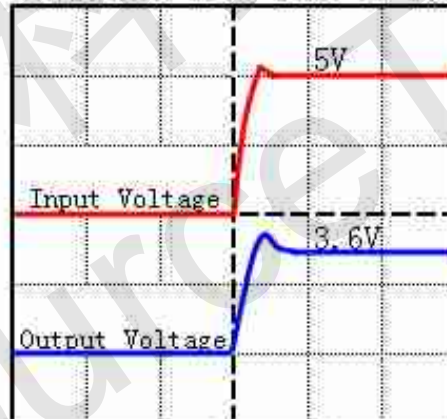

Time (5ms/div)

TX7150HPR I<sub>out</sub>=10mA CL=10uF

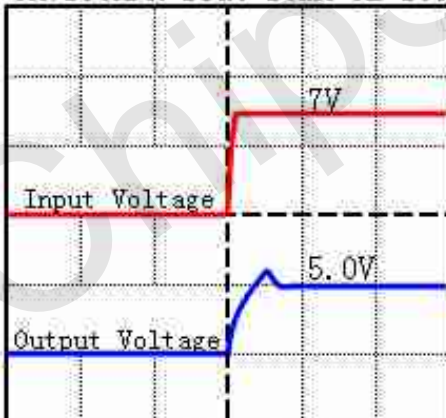

Time (5ms/div)

TX7150HPR I<sub>out</sub>=20mA CL=10uF

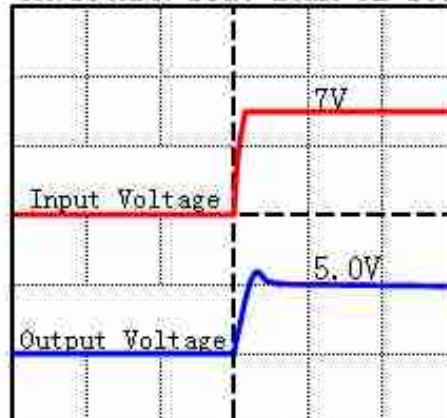

Time (5ms/div)



(4) Output Voltage vs.Ambient Temperature

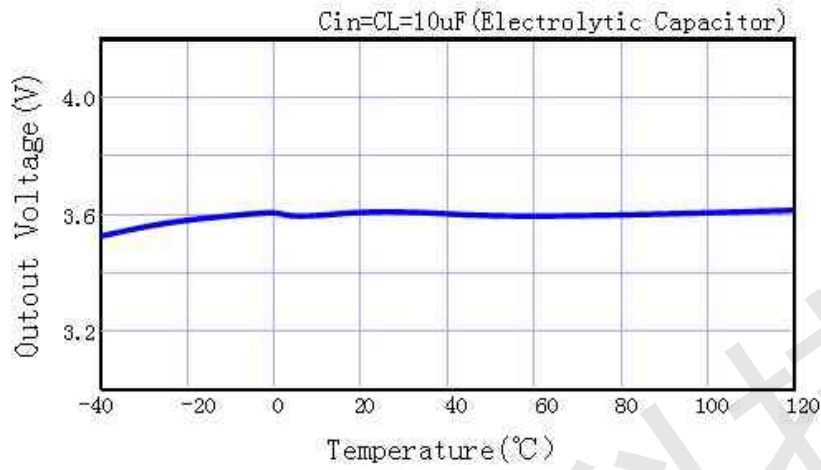



## Application Circuits

### Basic Circuits

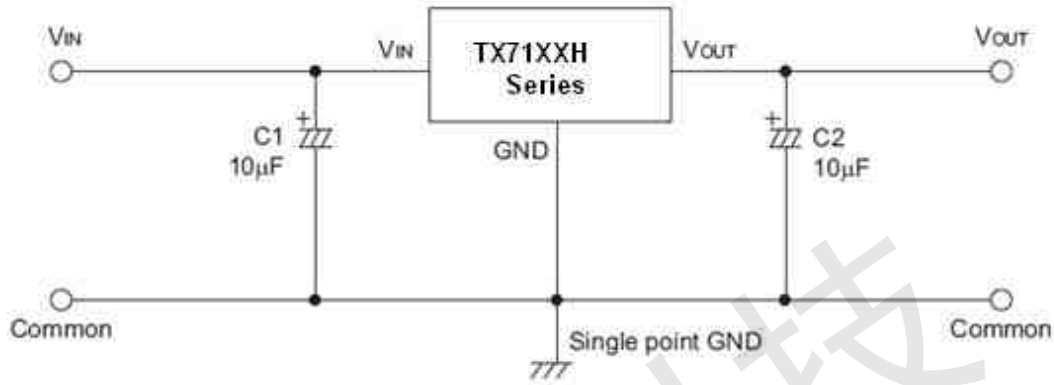

### High Output Current Positive Voltage Regulator

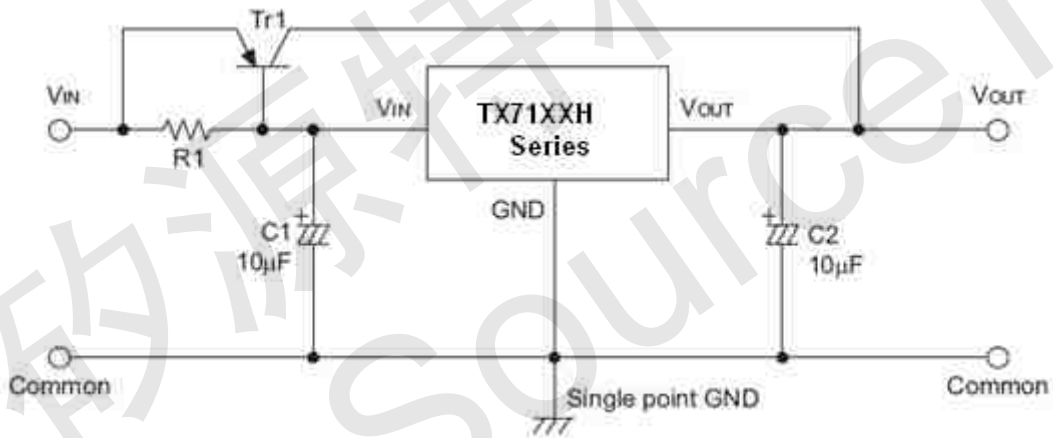

### Short-Circuit Protection by Tr1

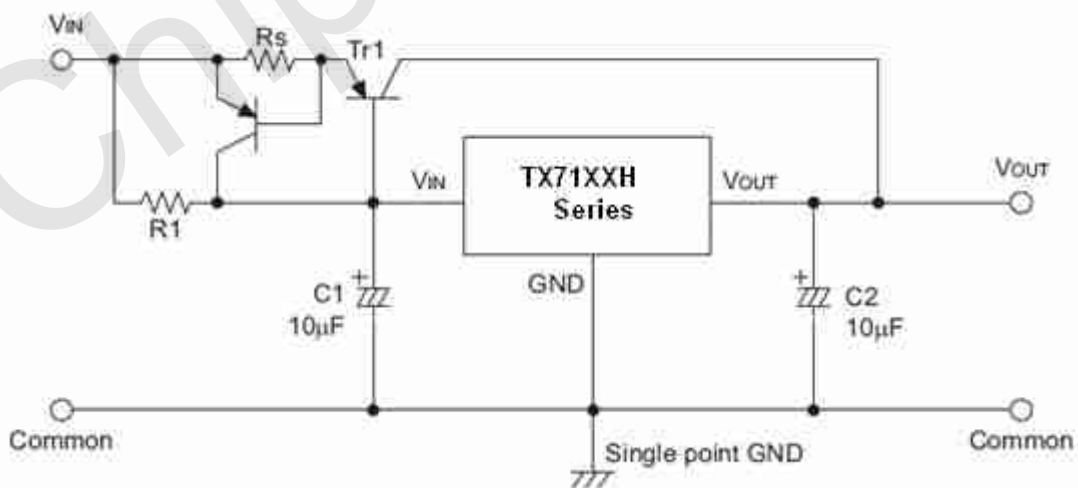



### Circuit for Increasing Output Voltage

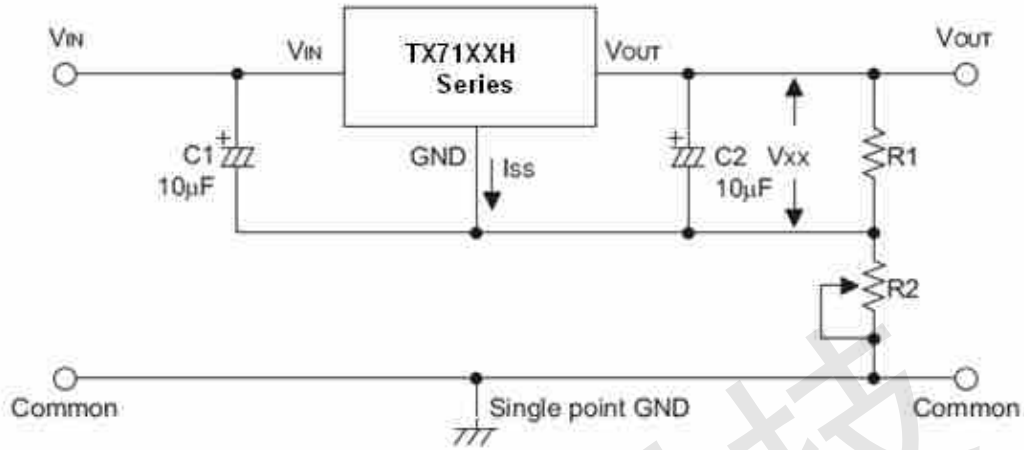

### Circuit for Increasing Output Voltage

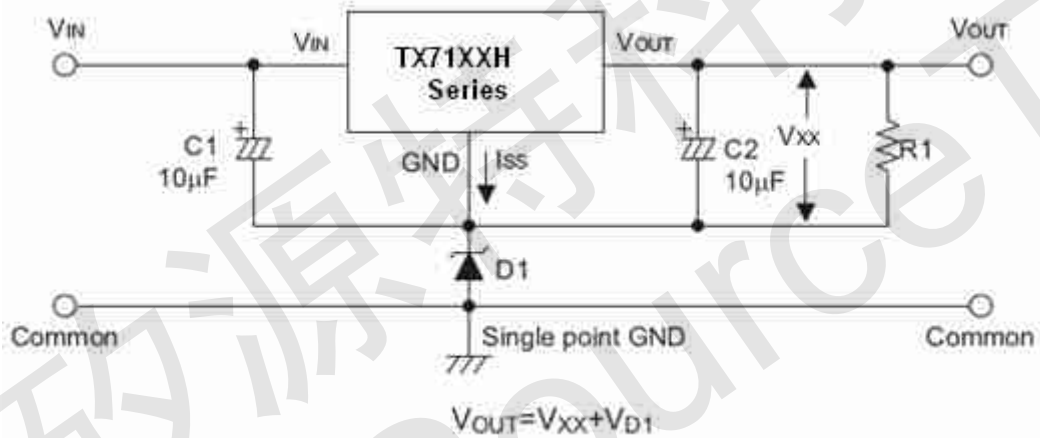

### Constant Current Regulator

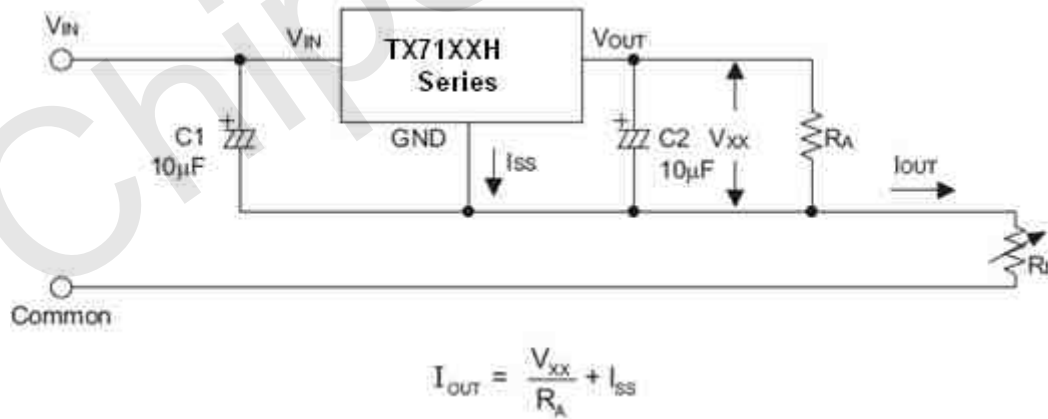



### Dual Supply

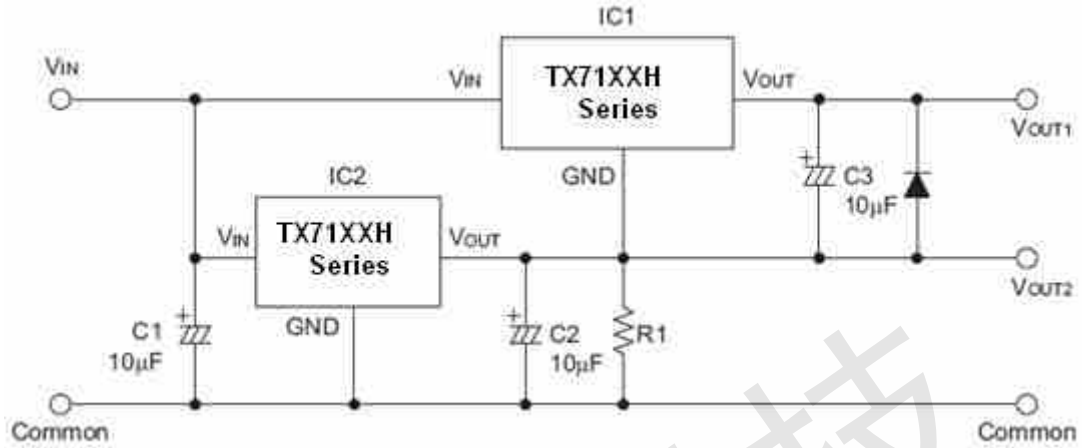





**Package Information**  
**3-pin TO92 Outline Dimensions**

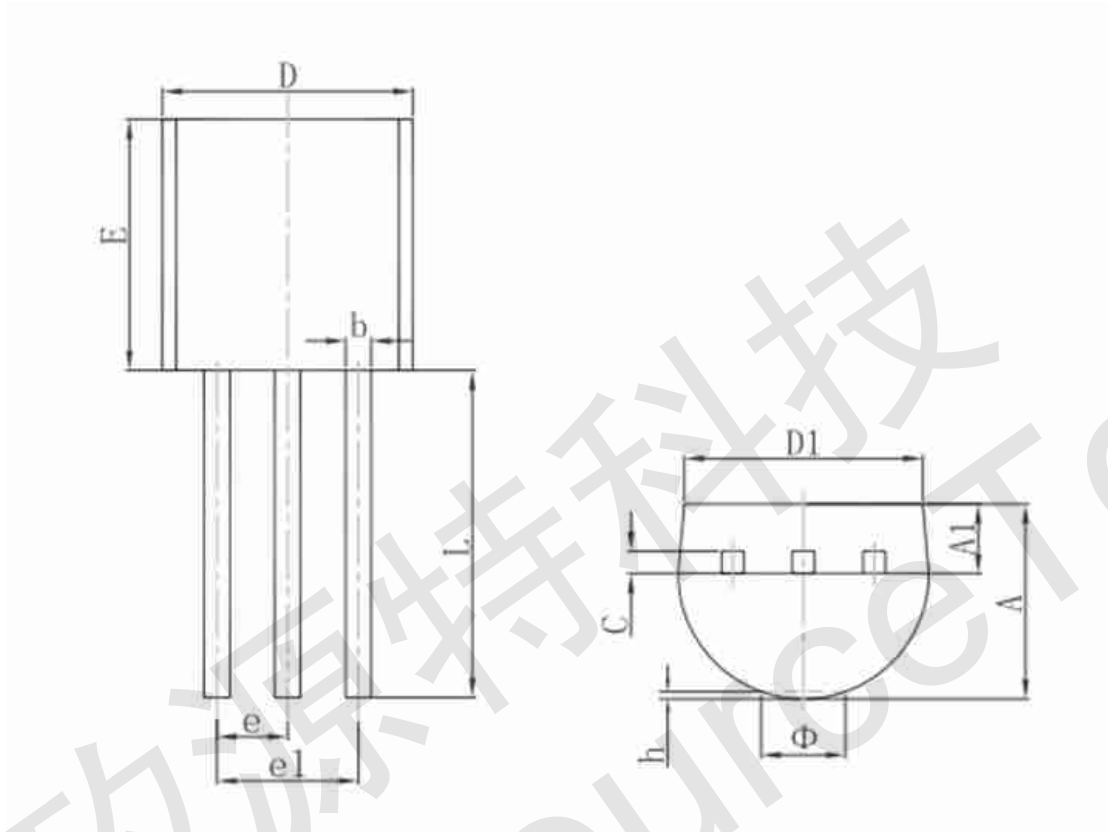

Symbol	Dimensions In Millimeters		Dimensions In Inches	
	Min.	Max.	Min.	Max.
A	3.300	3.700	0.130	0.146
A1	1.100	1.400	0.043	0.055
b	0.380	0.550	0.015	0.022
c	0.360	0.510	0.014	0.020
D	4.300	4.700	0.169	0.185
D1	3.430		0.135	
E	4.300	4.700	0.169	0.185
e	1.270 TYP.		0.050 TYP.	
e1	2.440	2.640	0.096	0.104
L	14.100	14.500	0.555	0.571
Φ		1.600		0.063
h	0.000	0.380	0.000	0.015





### 3-pin SOT89 Outline Dimensions

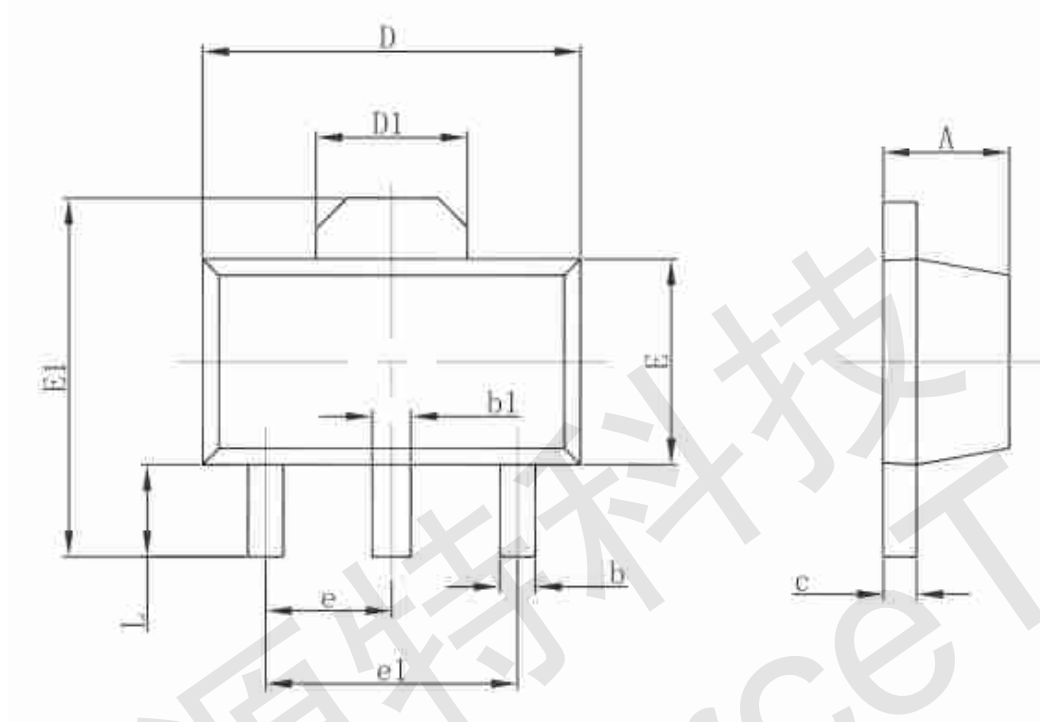

Symbol	Dimensions In Millimeters		Dimensions In Inches	
	Min.	Max.	Min.	Max.
A	1.400	1.600	0.055	0.063
b	0.320	0.520	0.013	0.020
b1	0.400	0.580	0.016	0.023
c	0.350	0.440	0.014	0.017
D	4.400	4.600	0.173	0.181
D1	1.550 REF.		0.061 REF.	
E	2.300	2.600	0.091	0.102
E1	3.940	4.250	0.155	0.167
e	1.500 TYP.		0.060 TYP.	
e1	3.000 TYP.		0.118 TYP.	
L	0.900	1.200	0.035	0.047



**Product Tape and Reel Specifications**  
**3-pin TO92 Reel Dimensions (Unit: mm)**

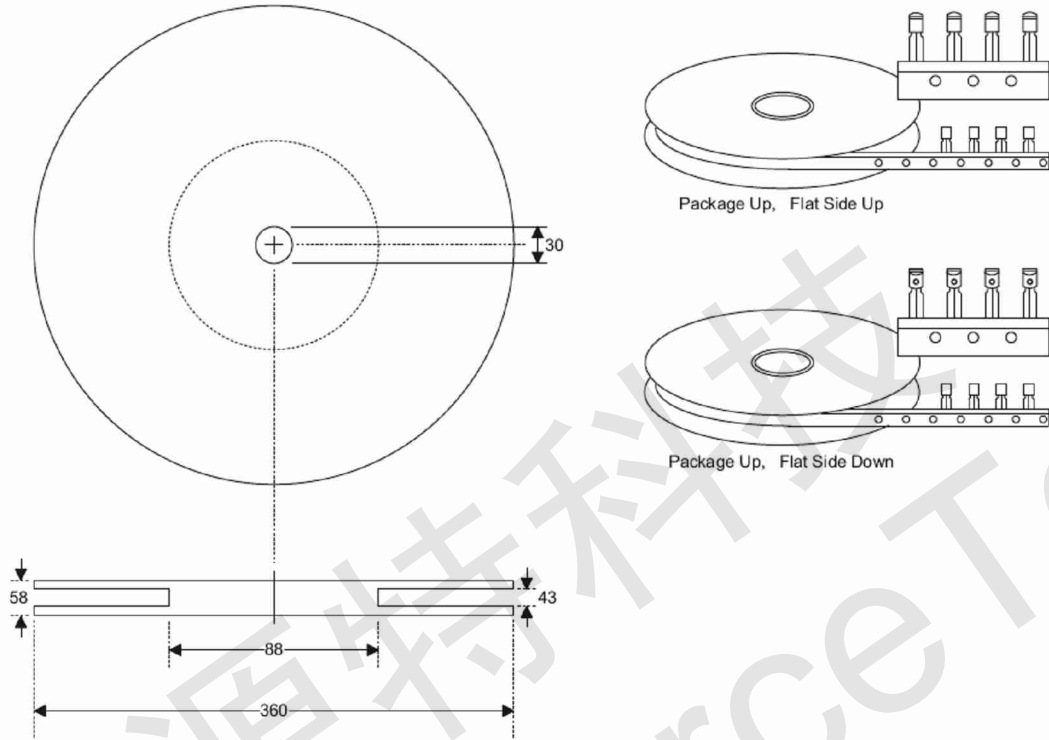



## Reel Dimensions

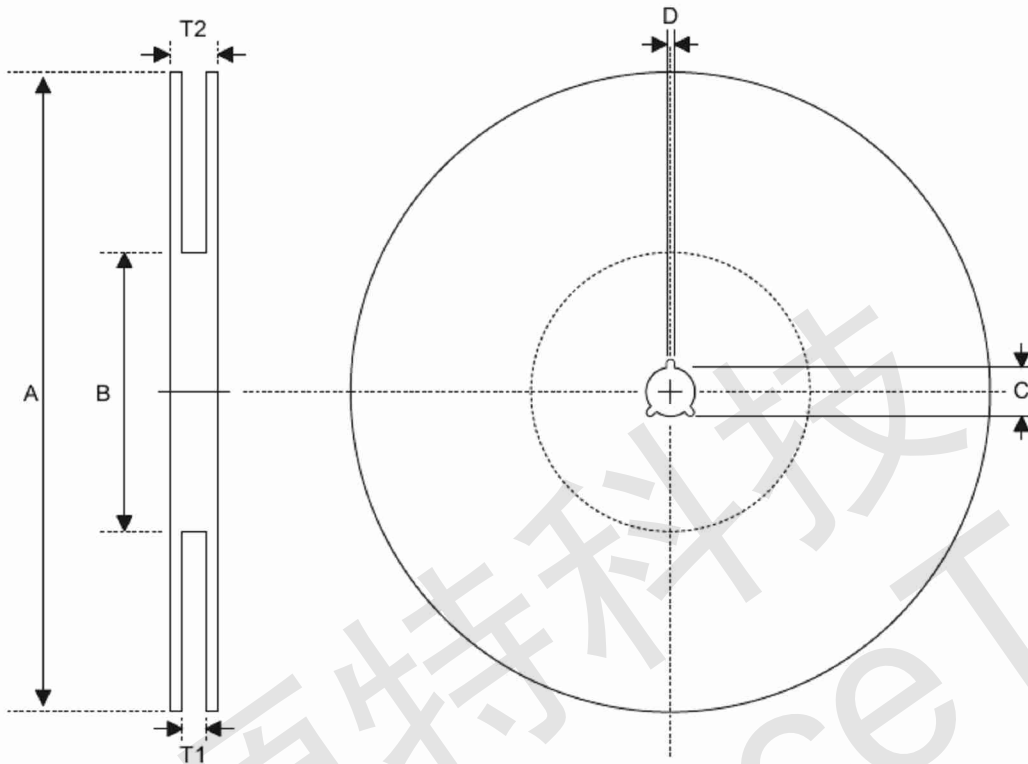

SOT89

Symbol	Description	Dimensions in mm
A	Reel Outer Diameter	180.0±1.0
B	Reel Inner Diameter	62.0±1.5
C	Spindle Hole Diameter	12.75 <sup>+0.15/-0.00</sup>
D	Key Slit Width	1.90±0.15
T1	Space Between Flange	12.4 <sup>+0.2/-0.00</sup>
T2	Reel Thickness	17.0 <sup>+0.0/-0.4</sup>

SOT23-5

Symbol	Description	Dimensions in mm
A	Reel Outer Diameter	178.0±1.0
B	Reel Inner Diameter	62.0±1.0
C	Spindle Hole Diameter	13.0±0.2
D	Key Slit Width	2.50±0.25
T1	Space Between Flange	8.4 <sup>+1.5/-0.0</sup>
T2	Reel Thickness	11.4 <sup>+1.5/-0.0</sup>



### Carrier Tape Dimensions

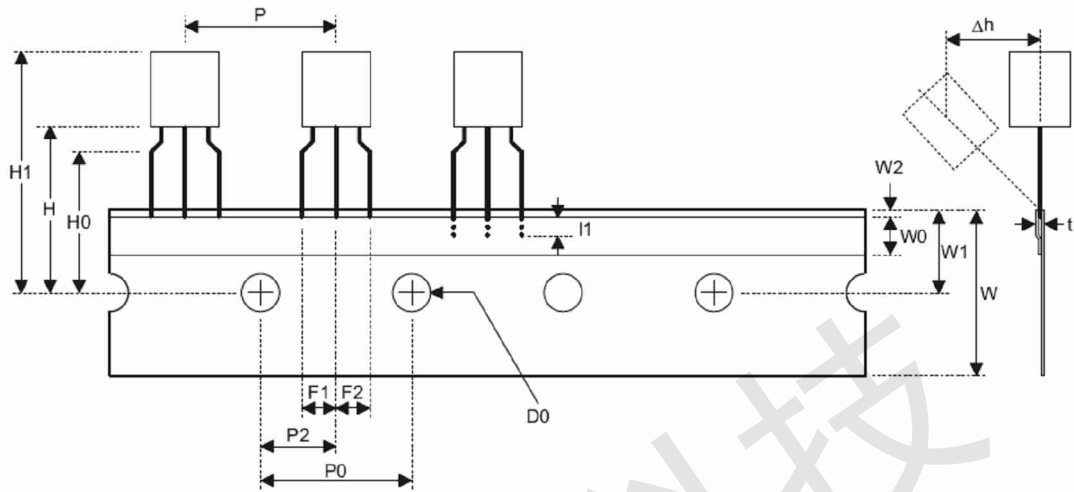

TO92

Symbol	Description	Dimensions in mm
I1	Taped Lead Length	(2.5)
P	Component Pitch	12.7±1.0
P <sub>0</sub>	Perforation Pitch	12.7±0.3
P <sub>2</sub>	Component to Perforation (Length Direction)	6.35±0.40
F <sub>1</sub>	Lead Spread	2.5 <sup>+0.4/-0.1</sup>
F <sub>2</sub>	Lead Spread	2.5 <sup>+0.4/-0.1</sup>
Δh	Component Alignment	0.0±0.1
W	Carrier Tape Width	18.0 <sup>+1.0/-0.5</sup>
W <sub>0</sub>	Hold-down Tape Width	6.0±0.5
W <sub>1</sub>	Perforation Position	9.0±0.5
W <sub>2</sub>	Hold-down Tape Position	(0.5)
H <sub>0</sub>	Lead Clinch Height	16.0±0.5
H <sub>1</sub>	Component Height	Less than 24.7
D <sub>0</sub>	Perforation Diameter	4.0±0.2
t	Taped Lead Thickness	0.7±0.2
H	Component Base Height	19.0±0.5

Note: Thickness less than 0.38\_0.05mm~0.5mm

P<sub>0</sub> Accumulated pitch tolerance: \_1mm/20pitches.

( ) Bracketed figures are for consultation only



### Carrier Tape Dimensions

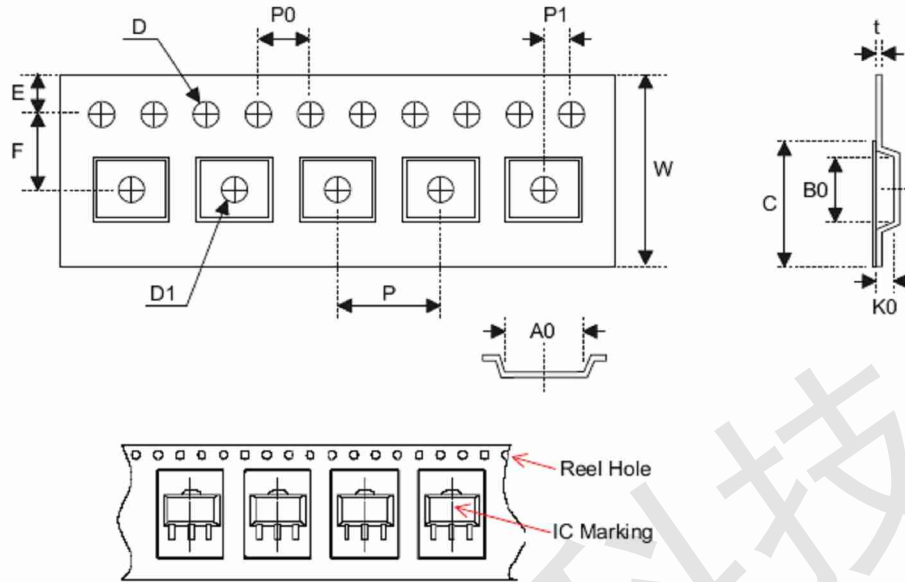

SOT89

Symbol	Description	Dimensions in mm
W	Carrier Tape Width	12.0 <sup>+0.3/-0.1</sup>
P	Cavity Pitch	8.0±0.1
E	Perforation Position	1.75±0.10
F	Cavity to Perforation (Width Direction)	5.50±0.05
D	Perforation Diameter	1.5 <sup>+0.1/-0.0</sup>
D1	Cavity Hole Diameter	1.5 <sup>+0.1/-0.0</sup>
P0	Perforation Pitch	4.0±0.1
P1	Cavity to Perforation (Length Direction)	2.0±0.1
A0	Cavity Length	4.8±0.1
B0	Cavity Width	4.5±0.1
K0	Cavity Depth	1.8±0.1
t	Carrier Tape Thickness	0.300±0.013
C	Cover Tape Width	9.3±0.1

SOT23-5

Symbol	Description	Dimensions in mm
W	Carrier Tape Width	8.0±0.3
P	Cavity Pitch	4.0±0.1
E	Perforation Position	1.75±0.10
F	Cavity to Perforation (Width Direction)	3.50±0.05
D	Perforation Diameter	1.5 <sup>+0.1/-0.0</sup>
D1	Cavity Hole Diameter	1.5 <sup>+0.1/-0.0</sup>
P0	Perforation Pitch	4.0±0.1
P1	Cavity to Perforation (Length Direction)	2.00±0.05
A0	Cavity Length	3.15±0.10
B0	Cavity Width	3.2±0.1
K0	Cavity Depth	1.4±0.1
t	Carrier Tape Thickness	0.20±0.03
C	Cover Tape Width	5.3±0.1