

**PRODUCT INFORMATION**

**FEATURES**

- Eight 10/100 Mbit/s Ethernet ports, each using a SMII interface
- Single 1000 Mbit/s Ethernet port, using a parallel GMII interface (lead shared with SMII interfaces)
- Ethernet Jumbo Frame support, all modes
- Ethernet Management interface for control
- Low latency throughput performance
- 64 ms differential delay compensation
- Configurable transmit and receive buffers up to 512 kbytes
- Provides IEEE 802.3 Half Duplex mode on 10/100 Mbit/s and Full Duplex mode on 10/100/1000 Mbit/s Ethernet ports
- Provides IEEE 802.3 Management Statistics (RMON)
- Ethernet frame encapsulation/decapsulation protocols:
  - ITU-T G.7041, Generic Framing Procedure (GFP)
  - ITU-T X.86/X.85, Link Access Procedure SDH (LAPS)
  - ITU-T Q.922, Link Access Procedure Frame Mode (LAPF)
  - RFC1662/3518, PPP Bridging Control Protocol (BCP)
- Performs mapping/demapping of encapsulated Ethernet frames into/from low order (VT1.5 SPE/VT2 SPE/VC-11/VC-12) and high order (STS-1 SPE/VC-3) virtually concatenated payloads
- Performs mapping/demapping of encapsulated Ethernet frames into/from a single contiguous concatenated (STS-3c-SPE/VC-4) payload or a single Low/High order (VT1.5/VT2/VC-11/VC-12/STS-1/VC-3) payload
- On-chip LCAS processing (ITU-T G.7042) for low and high order virtual concatenated payloads
- Glueless interface to external 64/128/256 Mbit SDRAM
- Low Order POH and Pointer processing for 84/63 VT1.5/VT2/TU-11/TU-12 and 3 TU-3
- High Order POH processing for STS-1 SPE/VC-3/STS-3c SPE/VC-4
- Byte-wide 19 MHz parallel Add and Drop Telecom Bus interfaces
- Per-port Ethernet side and SONET/SDH system side loopback for system level diagnostics
- 16-bit wide microprocessor interface, selectable between Motorola or Intel
- Boundary scan (IEEE 1149.1 standard)
- + 3.3V and +1.8V power supplies, 5V tolerant I/O leads
- 400-lead plastic ball grid array package (PBGA, 27 mm x 27 mm)
- Device Driver

**DESCRIPTION**

The EtherMap<sup>®</sup>-3 Pt (Platinum) is a highly integrated EoS device that provides for mapping of 10/100/1000 Mbit/s Ethernet into SONET/SDH STS-3/STM-1 Transport payloads with extremely low latency throughput. The device supports connection for up to eight 10/100 Mbit/s Ethernet ports, using SMII interfaces, or a single 1000 Mbit/s Ethernet port, using a GMII interface. Ethernet frames are encapsulated using either GFP, LAPS, LAPF or PPP/BCP protocol. The encapsulated Ethernet frames are then mapped into either virtually concatenated low or high order payloads, such as VT1.5 SPE/VT2 SPE/VC-11/VC-12/STS-1 SPE/VC-3, or into contiguously concatenated payloads such as STS-3c SPE/VC-4. Low and high order SONET/SDH POH generation and processing/termination is performed. A Telecom Bus provides the SONET/SDH interface.

In addition to support for full-rate Ethernet transfer, over-subscribed Ethernet transfers are also supported using back pressure mechanisms (half and full duplex flow control) in order to prevent frame loss. Configurable external SDRAM is used for buffering Ethernet frames to support bandwidth oversubscription, highly bursty traffic and flow control operation. Buffers are used as well for receive SONET/SDH container alignment and differential delay compensation of low and high order virtually concatenated payloads.

For both low and high order virtually concatenated payloads, optional on-chip standards based LCAS processing is provided to allow hitless dynamic bandwidth adjustments.

A powerful hardware and RTOS independent EtherMap family device driver provides full access to all the features of the device through APIs. It utilizes matched get/set functions and can be easily ported.

**APPLICATIONS**

- SONET/SDH Add/Drop and Terminal Multiplexers
- Multi-Service Access Platforms (MSAP)
- Compact Access or CPE Platforms
- IP DSLAMS
- Wireless Backhaul Electronics (RNC/BSC)
- Latency Sensitive Transport (FTP)

**TELECOM BUS SIDE**

**ETHERNET LINE SIDE**

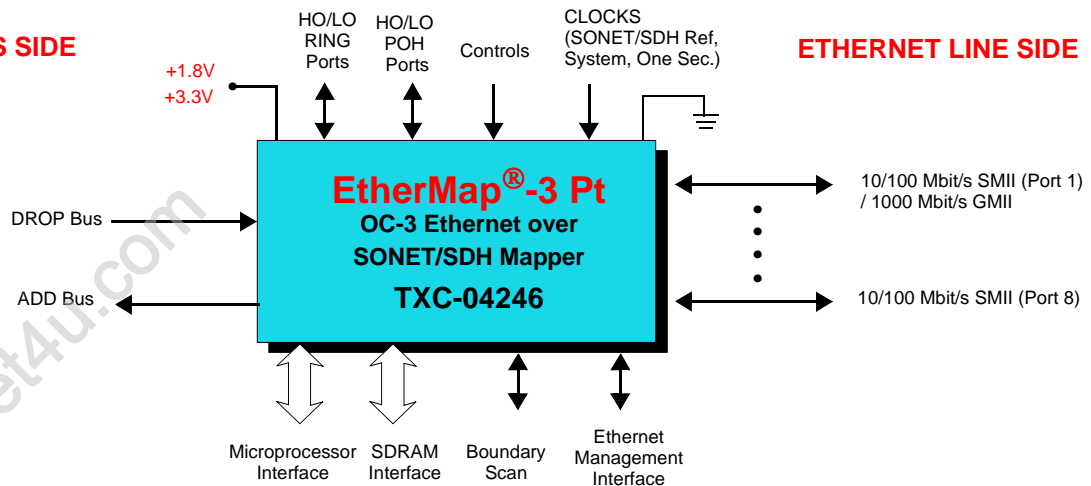

U.S. and/or foreign patents issued or pending  
 Copyright © 2004 TranSwitch Corporation  
 EtherMap, PHAST, TEMx28, TranSwitch and TXC  
 are registered trademarks of TranSwitch Corporation

Document Number:  
 TXC-04246-MC, Ed. 1  
 October 2004

**APPLICATION DIAGRAM**

**Multi-service Ethernet Aggregation with OC-3/STM-1 Uplink**

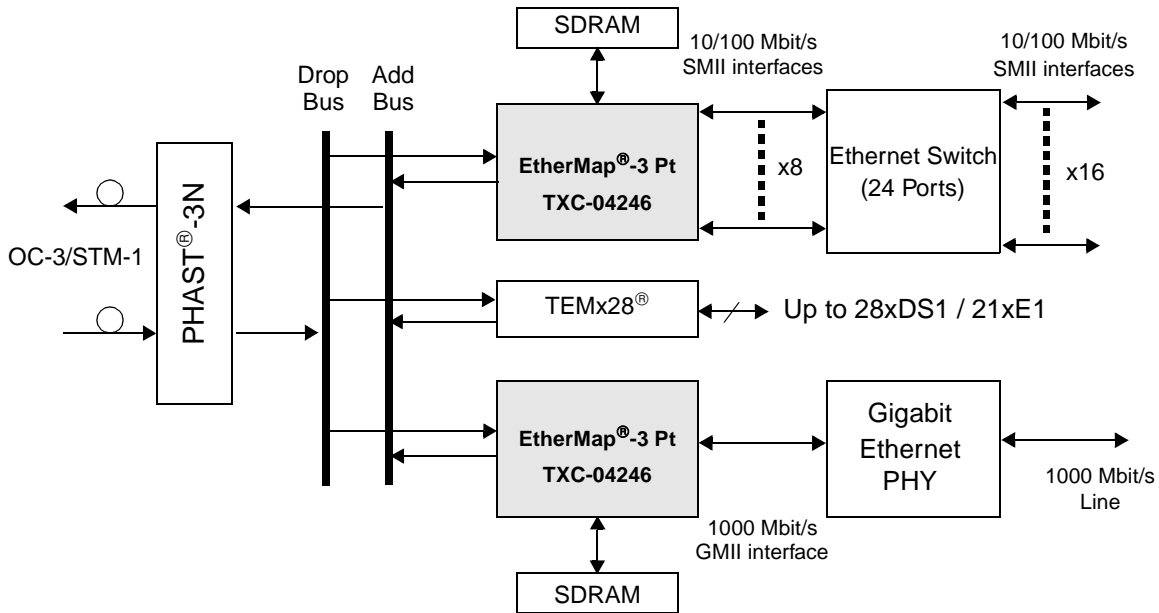

**RELATED PRODUCTS**

- TXC-03453 Triple Level 3 Mapper Device (TL3M)
- TXC-04222 28 Channel Dual Bus High Density Mapper Device (TEMx28<sup>®</sup>)
- TXC-06103 STM-1/STS-3/STS-3c SDH/SONET Overhead Terminator Device (PHAST<sup>®</sup>-3N)
- TXC-06212 Programmable, High Performance ATM/PPP/TDM SONET/SDH Terminator for Level 12 with Enhanced Features Device (PHAST<sup>®</sup>-12E)
- TXC-06312 STM-4/OC-12 SDH/SONET Overhead Terminator with Telecom Bus Interface Device (PHAST<sup>®</sup>-12N)
- TXC-06603 OC-12 SONET/SDH Path Overhead Processor, Retimer, and Cross Connect Device (POP-12)
- TXC-06712 OC-48 SONET/SDH Ethernet Mapper Device (EtherPHAST-48)
- TXC-06950 STM-4/STS-12 SDH/SONET TU/VT Processor and Cross-Connect Device (VXP-12)
- TXC-06951 STM-1/STS-3 SDH/SONET TU/VT Processor and Cross-Connect Device (VXP-6)

**FURTHER INFORMATION**

Contact TranSwitch for technical and ordering information on these products.

TranSwitch reserves the right to make changes to the product(s) or circuit(s) described herein without notice. No liability is assumed as a result of their use or application. No rights under any patent accompany the sale of any such product or circuit.

Document Number:  
TXC-04246-MC, Ed. 1  
October 2004