

DATA SHEET

TZA3041AHL; TZA3041BHL; TZA3041U

Gigabit Ethernet/Fibre Channel laser drivers

Preliminary specification
Supersedes data of 1998 Aug 24
File under Integrated Circuits, IC19

1999 Aug 24

Gigabit Ethernet/Fibre Channel laser drivers

TZA3041AHL; TZA3041BHL; TZA3041U

FEATURES

- 1.2 Gbits/s data input, both Current-Mode Logic (CML) and Positive Emitter Coupled Logic (PECL) compatible; maximum 800 mV (p-p)
- Adaptive laser output control with dual loop, stabilizing optical ONE and ZERO levels
- Optional external control of laser modulation and biasing currents (non-adaptive)
- Automatic laser shutdown
- Few external components required
- Rise and fall times of 120 ps (typical value)
- Jitter <50 mUI (p-p)
- RF output current sinking capability of 60 mA
- Bias current sinking capability of 90 mA
- Power dissipation of 430 mW (typical value)
- Low cost LQFP32 plastic package
- Single 5 V power supply.

TZA3041AHL

- Laser alarm output for signalling extremely low and high bias current conditions.

TZA3041BHL

- Extra 1.2 Gbits/s loop mode input; both CML and PECL compatible.

TZA3041U

- Bare die version with combined bias alarm and loop mode functionality.

APPLICATIONS

- Gigabit Ethernet/Fibre Channel optical transmission systems
- Gigabit Ethernet/Fibre Channel optical laser modules.

GENERAL DESCRIPTION

The TZA3041AHL, TZA3041BHL and TZA3041U are fully integrated laser drivers for Gigabit Ethernet/Fibre Channel (1.2 Gbits/s) systems, incorporating the RF path between the data multiplexer and the laser diode. Since the dual loop bias and modulation control circuits are integrated on the IC, the external component count is low. Only decoupling capacitors and adjustment resistors are required.

The TZA3041AHL features an alarm function for signalling extreme bias current conditions. The alarm low and high threshold levels can be adjusted to suit the application using only a resistor or a current Digital-to-Analog Converter (DAC).

The TZA3041BHL is provided with an additional RF data input to facilitate remote (loop mode) system testing.

The TZA3041U is a bare die version for use in compact laser module designs. The die contains 40 pads and features the combined functionality of the TZA3041AHL and the TZA3041BHL.

ORDERING INFORMATION

TYPE NUMBER	PACKAGE		
	NAME	DESCRIPTION	VERSION
TZA3041AHL	LQFP32	plastic low profile quad flat package; 32 leads; body 5 × 5 × 1.4 mm	SOT401-1
TZA3041BHL			
TZA3041U	–	bare die; 2000 × 2000 × 380 μm	–

Gigabit Ethernet/Fibre Channel laser drivers

TZA3041AHL; TZA3041BHL; TZA3041U

BLOCK DIAGRAMS

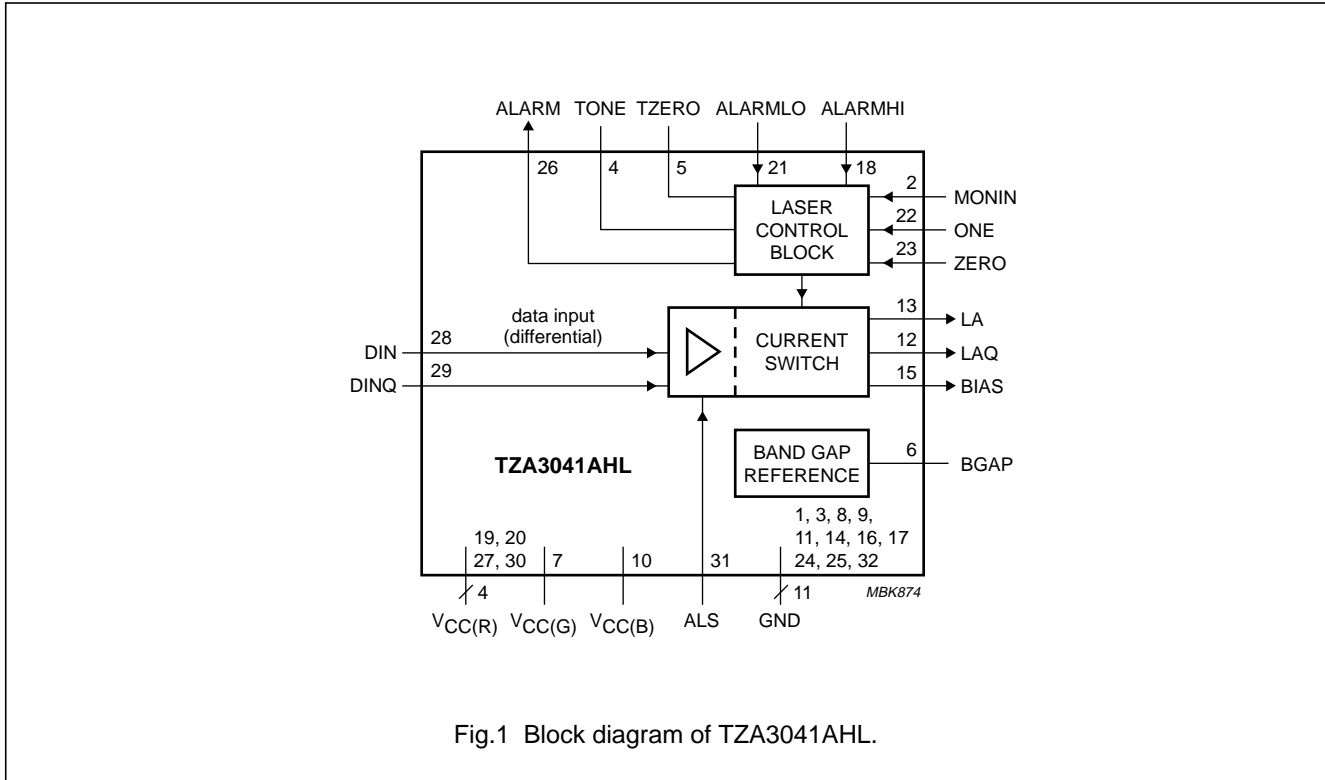

Fig.1 Block diagram of TZA3041AHL.

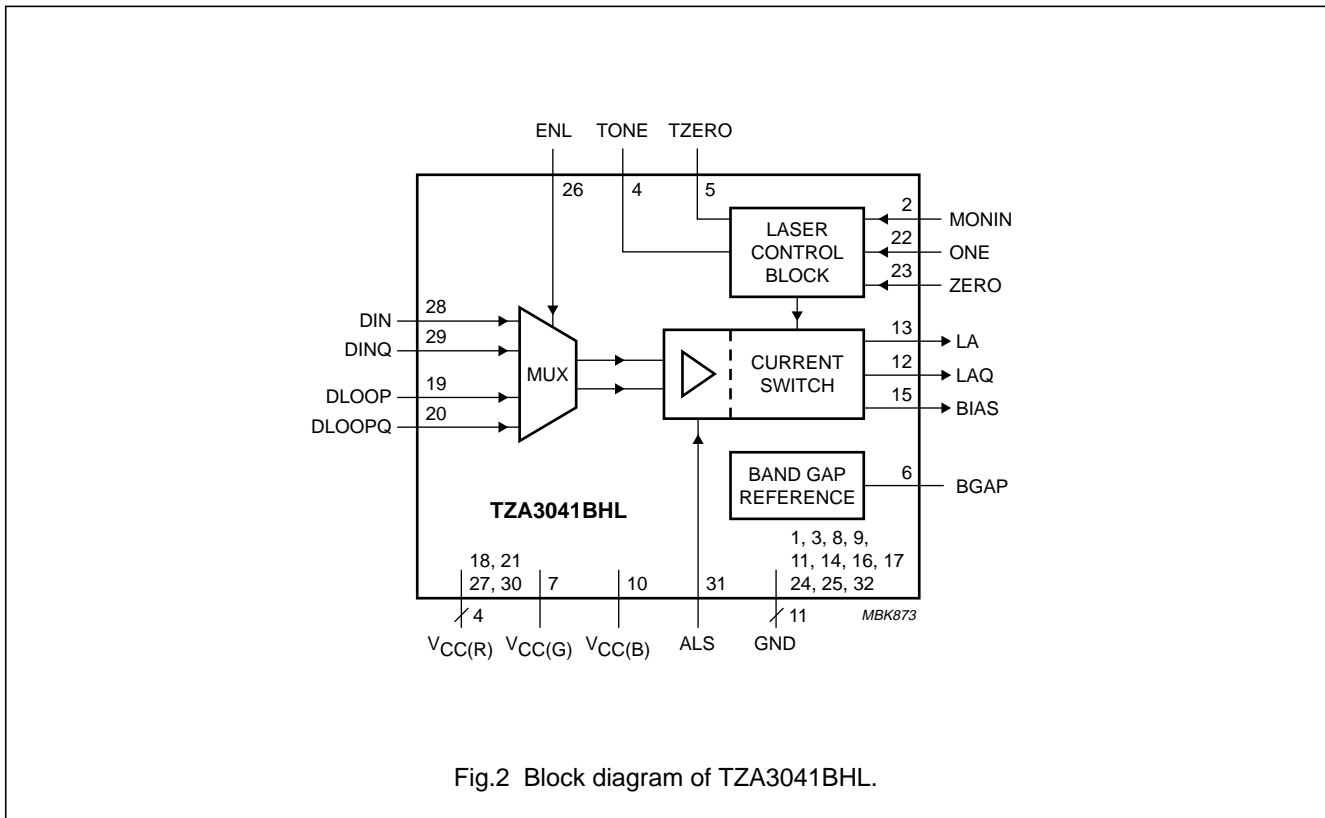

Fig.2 Block diagram of TZA3041BHL.

Gigabit Ethernet/Fibre Channel laser drivers

TZA3041AHL; TZA3041BHL; TZA3041U

PINNING

SYMBOL	PIN		PAD	DESCRIPTION
	TZA3041AHL	TZA3041BHL	TZA3041U	
GND	1	1	1	ground
MONIN	2	2	2	monitor photodiode current input
GND	3	3	3	ground
IGM	–	–	4	not used; leave unbonded
TONE	4	4	5	connection for external capacitor used to set optical ONE control loop time constant (optional)
TZERO	5	5	6	connection for external capacitor used to set optical ZERO control loop time constant (optional)
BGAP	6	6	7	connection for external band gap decoupling capacitor
V _{CC(G)}	7	7	8	supply voltage (green domain)
V _{CC(G)}	–	–	9	supply voltage (green domain)
GND	8	8	10	ground
GND	9	9	11	ground
V _{CC(B)}	10	10	12	supply voltage (blue domain)
V _{CC(B)}	–	–	13	supply voltage (blue domain)
GND	11	11	14	ground
LAQ	12	12	15	laser modulation output inverted
LA	13	13	16	laser modulation output
GND	14	14	17	ground
BIAS	15	15	18	laser bias current output
GND	16	16	19	ground
GND	17	17	20	ground
GND	–	–	21	ground
ALARMHI	18	–	22	maximum bias current alarm reference level input
V _{CC(R)}	–	18	23	supply voltage (red domain)
V _{CC(R)}	19	–	–	supply voltage (red domain)
DLOOP	–	19	24	loop mode data input
V _{CC(R)}	20	–	–	supply voltage (red domain)
DLOOPQ	–	20	25	loop mode data input inverted
V _{CC(R)}	–	–	26	supply voltage (red domain)
ALARMLO	21	–	27	minimum bias current alarm reference level input
V _{CC(R)}	–	21	–	supply voltage (red domain)
ONE	22	22	28	optical ONE reference level input
ZERO	23	23	29	optical ZERO reference level input
GND	24	24	30	ground
GND	25	25	31	ground
ALARM	26	–	32	alarm output
ENL	–	26	33	loop mode enable input
V _{CC(R)}	27	27	34	supply voltage (red domain)

Gigabit Ethernet/Fibre Channel
laser drivers

TZA3041AHL; TZA3041BHL;
TZA3041U

SYMBOL	PIN		PAD	DESCRIPTION
	TZA3041AHL	TZA3041BHL	TZA3041U	
DIN	28	28	35	data input
DINQ	29	29	36	data input inverted
V _{CC(R)}	30	30	37	supply voltage (red domain)
ALS	31	31	38	automatic laser shutdown input
GND	32	32	39	ground
GND	-	-	40	ground

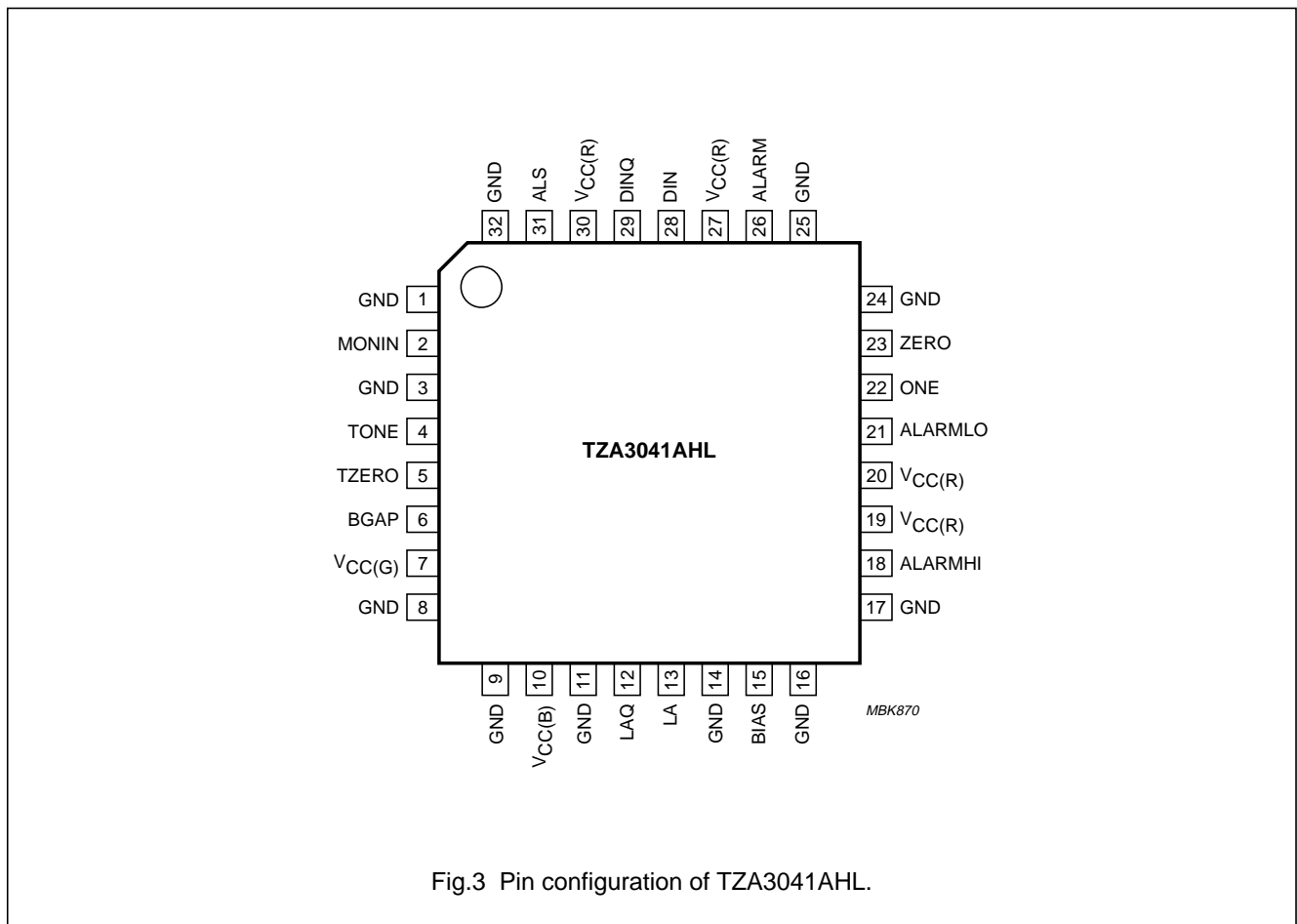

Fig.3 Pin configuration of TZA3041AHL.

Gigabit Ethernet/Fibre Channel
laser drivers

TZA3041AHL; TZA3041BHL;
TZA3041U

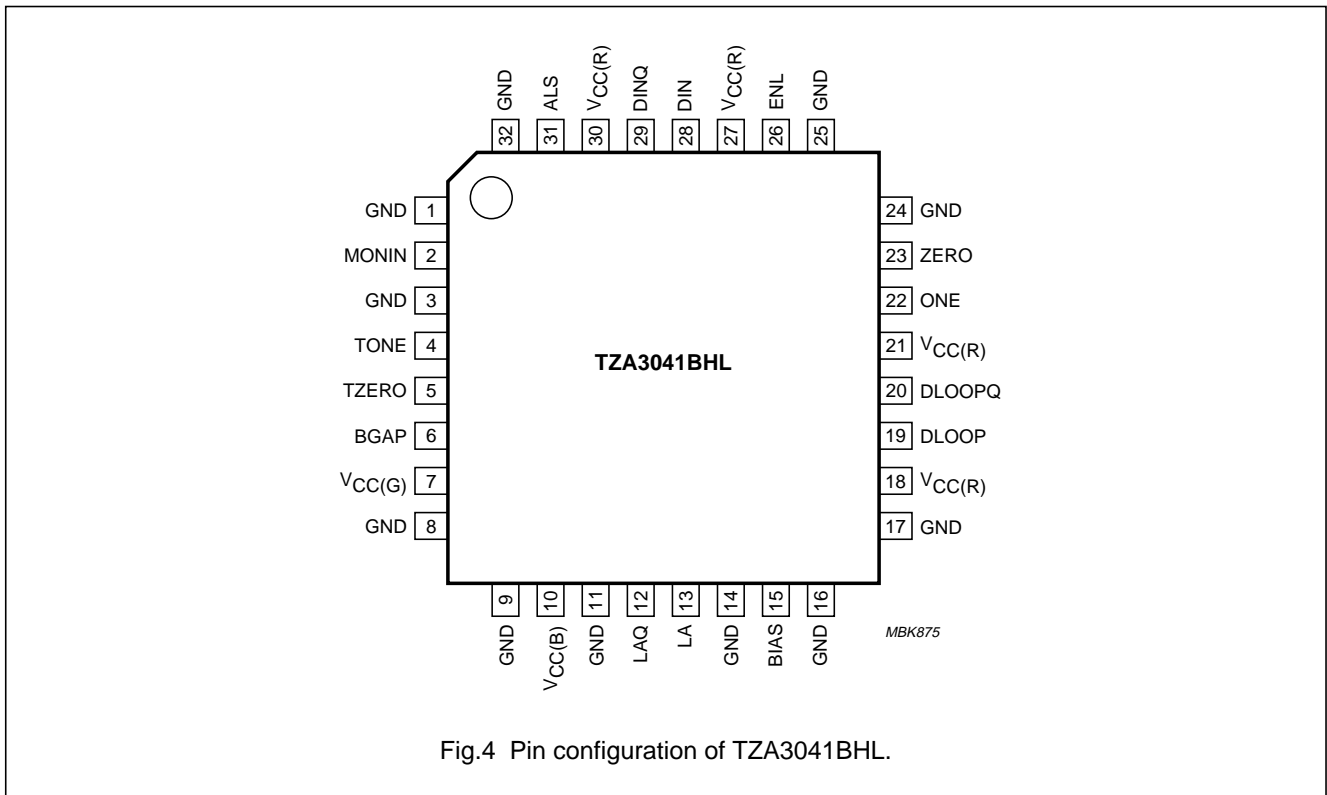

Fig.4 Pin configuration of TZA3041BHL.

FUNCTIONAL DESCRIPTION

The TZA3041AHL, TZA3041BHL and TZA3041U laser drivers accept a 1.2 Gbits/s Non-Return to Zero (NRZ) input data stream and generate an output signal with sufficient current to drive a solid state Fabry Perot (FP) or Distributed FeedBack (DFB) laser. They also contain dual loop control circuitry for stabilizing the true laser optical power levels representing logic 1 and logic 0.

The input buffers present a high impedance to the data stream on the differential inputs (pins DIN and DINQ). The input signal can be at CML level of approximately 200 mV (p-p) below the supply voltage, or at PECL level up to 800 mV (p-p). The inputs can be configured to accept CML signals by connecting external 50 Ω pull-up resistors between pins DIN and DINQ to V_{CC(R)}. If PECL compatibility is required, the usual Thevenin termination can be applied.

For ECL signals (negative and referenced to ground) the inputs should be AC-coupled to the signal source. If AC-coupling is applied, a constant input signal (either low or high) will bring the device in an undefined state. To avoid this, it is recommended to apply a slight offset to the input stage. The applied offset must be higher than the specified value in Chapter "Characteristics", but much lower than the applied input voltage swing.

The RF path is fully differential and contains a differential preamplifier and a main amplifier. The main amplifier is designed to handle large peak currents required at the output laser driving stage and is insensitive to supply voltage variations. The output signal from the main amplifier drives a current switch which supplies a guaranteed maximum modulation current of 60 mA at pins LA and LAQ. Pin BIAS delivers a guaranteed maximum DC bias current of up to 90 mA for adjusting the optical laser output to a level above its light emitting threshold.

Automatic laser control

A laser with a Monitor PhotoDiode (MPD) is required for the laser control circuit (see Figs 6 and 7).

The MPD current is proportional to the laser emission and is applied to pin MONIN. The MPD current range is from 100 to 1000 μA (p-p). The input buffer is optimized to cope with MPD capacitances up to 50 pF. To prevent the input buffer breaking into oscillation with a low MPD capacitance, it is required to increase the capacitance to the minimum value specified in Chapter "Characteristics" by connecting an extra capacitor between pin MONIN and V_{CC(G)}.

Gigabit Ethernet/Fibre Channel laser drivers

TZA3041AHL; TZA3041BHL; TZA3041U

DC reference currents are applied to pins ZERO and ONE to set the MPD reference levels for laser LOW and laser HIGH. A resistor connected between pin ZERO and $V_{CC(R)}$ and a resistor connected between pin ONE and $V_{CC(R)}$ is sufficient, but current DACs can also be used.

The voltages on pins ZERO and ONE are held constant at a level of 1.5 V below $V_{CC(R)}$. The reference current applied to pin ZERO is multiplied by 4 and the reference current flowing into pin ONE is multiplied internally by 16.

The reference current and the resistor for the optical ONE regulation loop (modulation current control) can be calculated using the following formulae:

$$I_{ONE} = \frac{1}{16} \times I_{MPD(ONE)} \quad [A] \quad (1)$$

$$R_{ONE} = \frac{1.5}{I_{ONE}} = \frac{24}{I_{MPD(ONE)}} \quad [\Omega] \quad (2)$$

The reference current and resistor for the optical ZERO regulation loop (bias current control) can be calculated using the following formulae:

$$I_{ZERO} = \frac{1}{4} \times I_{MPD(ZERO)} \quad [A] \quad (3)$$

$$R_{ZERO} = \frac{1.5}{I_{ZERO}} = \frac{6}{I_{MPD(ZERO)}} \quad [\Omega] \quad (4)$$

In these formulae, $I_{MPD(ONE)}$ and $I_{MPD(ZERO)}$ represent the monitor photodiode current during an optical ONE and an optical ZERO, respectively.

Example: A laser is operating at optical output power levels of 0.3 mW for laser HIGH and 0.03 mW for laser LOW (extinction ratio of 10 dB). Suppose the corresponding MPD currents for this type of laser are 260 and 30 μ A, respectively.

In this example the reference current is

$$I_{ONE} = \frac{1}{16} \times 260 = 16.25 \mu A \text{ and flows into pin ONE.}$$

This current can be set using a current source or simply by a resistor of the appropriate value connected between pin ONE and $V_{CC(R)}$. In this example the resistor would be

$$R_{ONE} = \frac{1.5}{16.25} = 92.3 \text{ k}\Omega$$

The reference current at pin ZERO in this example is

$$I_{ZERO} = \frac{1}{4} \times 30 = 7.5 \mu A \text{ and can be set using a resistor}$$

$$R_{ZERO} = \frac{1.5}{7.5} = 200 \text{ k}\Omega$$

It should be noted that the MPD current is stabilized, rather than the actual laser optical output power. Deviations between optical output power and MPD current, known as 'tracking errors', cannot be corrected.

Designing the modulation and bias loop

The optical ONE and ZERO regulation loop time constants are determined by on-chip capacitances. If the resulting time constants are found to be too small in a specific application, they can be increased by connecting external capacitors to pins TZERO and TONE, respectively.

The optical ONE loop time constant and bandwidth can be estimated using the following formulae:

$$\tau_{ONE} = (40 \times 10^{-12} + C_{TONE}) \times \frac{80 \times 10^3}{\eta_{LASER}} \quad [s] \quad (5)$$

$$B_{ONE} = \frac{1}{2\pi \times \tau_{ONE}} \quad [Hz] \quad (6)$$

$$B_{ONE} = \frac{\eta_{LASER}}{2\pi \times (40 \times 10^{-12} + C_{TONE}) \times 80 \times 10^3}$$

The optical ZERO loop time constant and bandwidth can be estimated using the following formulae:

$$\tau_{ZERO} = (40 \times 10^{-12} + C_{TZERO}) \times \frac{50 \times 10^3}{\eta_{LASER}} \quad [s] \quad (7)$$

$$B_{ZERO} = \frac{1}{2\pi \times \tau_{ZERO}} \quad [Hz] \quad (8)$$

$$B_{ZERO} = \frac{\eta_{LASER}}{2\pi \times (40 \times 10^{-12} + C_{TZERO}) \times 50 \times 10^3}$$

The term η_{LASER} (dimensionless) in the above formulae is the product of the two terms:

- η_{EO} is the electro-optical efficiency which accounts for the steepness of the laser slope. It is the amount of the extra optical output power in W/A of modulation current optical output power.
- R is the monitor photodiode responsivity. It is the amount of the extra monitor photodiode current in A/W optical output power.

Gigabit Ethernet/Fibre Channel laser drivers

TZA3041AHL; TZA3041BHL; TZA3041U

Example: A laser with an MPD has the following specifications: $P_O = 1$ mW, $I_{th} = 25$ mA, $\eta_{EO} = 30$ mW/A, $R = 500$ mA/W. The term I_{th} is the required threshold current to switch-on the laser. If the laser operates just above the threshold level, it may be assumed that η_{EO} around the optical ZERO level is 50% of η_{EO} around the optical ONE level, due to the decreasing slope near the threshold level.

In this example the resulting bandwidth for the optical ONE regulation loop, without external capacitance, would be:

$$B_{ONE} = \frac{30 \times 10^{-3} \times 500 \times 10^{-3}}{2\pi \times 40 \times 10^{-12} \times 80 \times 10^3} \approx 750 \text{ Hz}$$

The resulting bandwidth for the optical ZERO regulation loop, without external capacitance, would be:

$$B_{ZERO} = \frac{0.5 \times 30 \times 10^{-3} \times 500 \times 10^{-3}}{2\pi \times 40 \times 10^{-12} \times 50 \times 10^3} \approx 600 \text{ Hz}$$

It is not necessary to add additional capacitance with this type of laser.

Data pattern and bit rate dependency of the control loop

The constants in Equations (1) and (3) are valid, provided a frequent presence of sufficiently long runs of 'constant zero' and 'constant one'. The longest run of zeros and ones, occurring typically within a single loop time period (τ_{ONE} and τ_{ZERO}), must be at least approximately 6 ns. If the longest run of zeros and ones has a lower, but constant value, there will be a measurable, but fixed deviation in the scaling factors in Equations (1) and (3). In practice, it can be witnessed that the optical extinction ratio will increase if the bit rate is increased. Therefore it is important to use the actual data patterns and bit rate of the final application circuit for adjusting the optical levels.

Monitoring the bias and modulation current

Although not recommended, the bias and modulation currents generated by the laser driver can be monitored by measuring the voltages on pins TZERO and TONE, respectively. The relations between these voltages and the corresponding currents are given as transconductance values and are specified in Chapter "Characteristics". The voltages on pins TZERO and TONE range from 1.4 to 3.4 V. The impedance connected at these pins should have an extremely high value. It is mandatory to use a CMOS buffer or an amplifier with an input impedance higher than 100 G Ω and an extremely low input leakage current (pA range).

Manual laser override

The automatic laser control function can be overridden by connecting voltage sources to pins TZERO and TONE to take direct control of, respectively, the bias current source and the modulation current source. The control voltages should be in the range from 1.4 to 3.4 V to sweep the modulation current through the range from 1 to 60 mA and the bias current through the range from 1 to 90 mA. These current ranges are guaranteed. Depending on the temperature and manufacturing process spread, current values higher than the specified ranges can be achieved. However, bias and modulation currents in excess of the specified range are not supported and should be avoided.

Currents into or out pins TZERO and TONE in excess of 10 μ A must be avoided to prevent damage of the circuit.

Automatic laser shut-down and laser slow start

The laser modulation and bias currents can be rapidly switched off when a HIGH-level (CMOS) is applied to pin ALS. This function allows the circuit to be shut-down in the event of an optical system malfunction. A 25 k Ω pull-down resistor defaults the input of pin ALS to the non active state.

When a LOW-level is applied to pin ALS, the modulation and bias current slowly increase to the desired values with the typical time constants of τ_{ONE} and τ_{ZERO} , respectively. This can be used as a laser slow start.

Bias alarm for TZA3041AHL

The bias current alarm circuit detects and flags whenever the bias current is outside a predefined range. This feature can detect excessive bias current due to laser aging and laser malfunctioning. The maximum permitted bias current should be applied to pin ALARMHI with an attenuation ratio of 1500; the minimum to pin ALARMLO with an attenuation ratio of 300.

Like the reference currents for the laser current control loop, the alarm reference currents can be set using external resistors connected between pins ALARMHI or ALARMLO and $V_{CC(R)}$. The resistor values can be calculated using the following formulae:

$$R_{ALARMHI} = \frac{1.5 \times 1500}{I_{BIAS(max)}} \quad [\Omega] \quad (9)$$

$$R_{ALARMLO} = \frac{1.5 \times 300}{I_{BIAS(min)}} \quad [\Omega] \quad (10)$$

Gigabit Ethernet/Fibre Channel laser drivers

TZA3041AHL; TZA3041BHL; TZA3041U

Example: The following reference currents are required to limit the bias current range between 6 and 90 mA:

$$I_{\text{ALARMLO}} = \frac{6 \text{ mA}}{300} = 20 \text{ } \mu\text{A} \text{ and}$$

$$I_{\text{ALARMHI}} = \frac{90 \text{ mA}}{1500} = 60 \text{ } \mu\text{A}$$

The corresponding resistor values are:

$$R_{\text{ALARMHI}} = \frac{1.5 \text{ V} \times 1500}{90 \text{ mA}} = 25 \text{ k}\Omega \text{ and}$$

$$R_{\text{ALARMLO}} = \frac{1.5 \text{ V} \times 300}{6 \text{ mA}} = 75 \text{ k}\Omega$$

If the alarm condition is true, the voltage on pin ALARM goes to HIGH-level (CMOS). This signal could be used, for example, to disable the laser driver by driving pin ALS (a latch is needed in between to prevent oscillation).

Loop mode for TZA3041BHL

In the loop mode the total system application can be tested. It allows for uninhibited optical transmission through the fibre front-end (from the photodiode through the transimpedance stage and the data and clock recovery unit, to the laser driver and via the laser back to the fibre). It should be noted that the optical receiver used in conjunction with the TZA3041BHL must have a loop mode output in order to complete the test loop.

A HIGH-level on pin ENL selects the loop mode. By default pin ENL is pulled at LOW-level by a 25 k Ω pull-down resistor.

Power supply connections

Three separate supply domains [labelled $V_{\text{CC(B)}}$, $V_{\text{CC(G)}}$ and $V_{\text{CC(R)}}$] are used to provide isolation between the high-current outputs, the PECL or CML inputs, and the monitor photodiode current input. The three domains should be individually filtered before being connected to a central V_{CC} (see Figs 6 and 7). **All supply pins need to be connected.** The supply levels should be equal and in accordance with the values specified in Chapter "Characteristics".

To maximize power supply isolation, the MPD cathode on the laser should be connected to $V_{\text{CC(G)}}$ and the laser diode anode to $V_{\text{CC(B)}}$. It is recommended to provide the laser anode with a separate decoupling capacitor C11.

The inverted laser driver modulation pin LAQ is generally not used. To properly balance the output stage, an equalization network Z1 with an impedance comparable to the laser is connected between pin LAQ and $V_{\text{CC(B)}}$.

All external components should be SMD, preferably of size 0603 or smaller. The components must be mounted as close to the IC as possible. It is specially recommended to mount the following components very close to the IC:

- Power supply decoupling capacitors C2, C4 and C6
- Input matching network on pins DIN and DINQ
- Capacitor C7 on pin MONIN
- Output matching network Z1 at the unused output.

Grounding bare die

In addition to the separate V_{CC} domains, the bare die contains three corresponding ground domains. Isolation between the GND domains is limited due to the finite substrate conductance.

Mount the die on a, preferably large and highly conductive, grounded die pad. **All pads GND have to be bonded to the die pad.** The external ground is thus optimally combined with the die ground, avoiding ground bouncing problems.

Layout recommendations

Layout recommendations for the TZA3041AHL and TZA3041BHL can be found in application note "AN98090 Fiber optic transceiverboard STM1/4/8, OC3,12,24, FC/GE".

Gigabit Ethernet/Fibre Channel laser drivers

TZA3041AHL; TZA3041BHL; TZA3041U

LIMITING VALUES

In accordance with the Absolute Maximum Rating System (IEC 134).

SYMBOL	PARAMETER	CONDITIONS	MIN.	MAX.	UNIT
V_{CC}	supply voltage		-0.5	+6	V
V_n	DC voltage on				
	pin MONIN		1.3	$V_{CC} + 0.5$	V
	pins TONE and TZERO		-0.5	$V_{CC} + 0.5$	V
	pin BGAP		-0.5	+3.2	V
	pin BIAS		-0.5	$V_{CC} + 0.5$	V
	pins LA and LAQ		1.3	$V_{CC} + 0.5$	V
	pin ALS		-0.5	$V_{CC} + 0.5$	V
	pins ONE and ZERO		-0.5	$V_{CC} + 0.5$	V
	pins DIN and DINQ		-0.5	$V_{CC} + 0.5$	V
	pin ALARM	TZA3041AHL	-0.5	$V_{CC} + 0.5$	V
	pins ALARMHI and ALARMLO	TZA3041AHL	-0.5	$V_{CC} + 0.5$	V
	pins DLOOP and DLOOPQ	TZA3041BHL	-0.5	$V_{CC} + 0.5$	V
	pin ENL	TZA3041BHL	-0.5	$V_{CC} + 0.5$	V
I_n	DC current on				
	pin MONIN		-0.5	+2.5	mA
	pins TONE and TZERO		-0.5	+0.5	mA
	pin BGAP		-2.0	+2.5	mA
	pin BIAS		-0.5	+200	mA
	pins LA and LAQ		-0.5	+100	mA
	pin ALS		-0.5	+0.5	mA
	pins ONE and ZERO		-0.5	+0.5	mA
	pins DIN and DINQ		-0.5	+0.5	mA
	pin ALARM	TZA3041AHL	-0.5	+10	mA
	pins ALARMHI and ALARMLO	TZA3041AHL	-0.5	+0.5	mA
	pins DLOOP and DLOOPQ	TZA3041BHL	-0.5	+0.5	mA
	pin ENL	TZA3041BHL	-0.5	+0.5	mA
T_{amb}	ambient temperature		-40	+85	°C
T_j	junction temperature		-40	+125	°C
T_{stg}	storage temperature		-65	+150	°C

THERMAL CHARACTERISTICS

SYMBOL	PARAMETER	VALUE	UNIT
$R_{th(j-s)}$	thermal resistance from junction to solder point	15	K/W
$R_{th(j-c)}$	thermal resistance from junction to case	23	K/W

Gigabit Ethernet/Fibre Channel laser drivers

TZA3041AHL; TZA3041BHL; TZA3041U

CHARACTERISTICS

$V_{CC} = 5\text{ V}$; $T_{amb} = -40\text{ to }+85\text{ }^{\circ}\text{C}$; all voltages measured with respect to GND.

SYMBOL	PARAMETER	CONDITIONS	MIN.	TYP.	MAX.	UNIT
Supply						
V_{CC}	supply voltage		4.75	5	5.25	V
I_{CC}	supply current	note 1	–	65	90	mA
P_{tot}	total power dissipation	note 2	–	430	810	mW
Data inputs: pins DIN and DINQ (and pins DLOOP and DLOOPQ on TZA3041BHL); see Fig.5						
$V_{i(p-p)}$	input voltage (peak-to-peak value)	differential	100	250	800	mV
V_{IO}	input offset voltage		–25	–	+25	mV
$V_{I(min)}$	minimum input voltage		$V_{CC(R)} - 2$	–	–	V
$V_{I(max)}$	maximum input voltage		–	–	$V_{CC(R)} + 0.25$	V
Z_i	input impedance	for low frequencies; single-ended	8	10	12	k Ω
CMOS inputs: pin ALS (and pin ENL on TZA3041BHL)						
V_{IL}	LOW-level input voltage		–	–	1.5	V
V_{IH}	HIGH-level input voltage		3.5	–	–	V
$R_{pd(ALS)}$	internal pull-down resistance on pin ALS		21	25.5	30	k Ω
$R_{pd(ENL)}$	internal pull-down resistance on pin ENL		15	25	35	k Ω
CMOS output: pin ALARM (on TZA3041AHL)						
V_{OL}	LOW-level output voltage	$I_{OH} = -200\text{ }\mu\text{A}$	0	–	0.2	V
V_{OH}	HIGH-level output voltage	$I_{OH} = 200\text{ }\mu\text{A}$	4.8	–	5	V
Monitor photodiode input: pin MONIN						
V_I	DC input voltage		1.5	1.8	2.0	V
I_{MPD}	monitor photodiode current	laser optical '0'	24	–	260	μA
		laser optical '1'	96	–	1040	μA
C_{MPD}	monitor photodiode capacitance	note 3	30	–	50	pF
Control loop reference currents: pins ONE and ZERO						
$I_{ref(ONE)}$	reference current on pin ONE	note 4	6	–	65	μA
$V_{ref(ONE)}$	reference voltage on pin ONE	referenced to $V_{CC(R)}$	–1.55	–1.5	–1.45	V
$I_{ref(ZERO)}$	reference current on pin ZERO	note 4	6	–	65	μA
$V_{ref(ZERO)}$	reference voltage on pin ZERO	referenced to $V_{CC(R)}$	–1.55	–1.5	–1.45	V
Control loop time constants: pins TONE and TZERO						
V_{TONE}	voltage on pin TONE	floating output	1.4	–	3.4	V
$g_m(TONE)$	transconductance of pin TONE	note 5	–	100	–	mA/V
V_{TZERO}	voltage on pin TZERO	floating output	1.4	–	3.4	V
$g_m(TZERO)$	transconductance of pin TZERO	note 6	–	160	–	mA/V

Gigabit Ethernet/Fibre Channel laser drivers

TZA3041AHL; TZA3041BHL;
TZA3041U

SYMBOL	PARAMETER	CONDITIONS	MIN.	TYP.	MAX.	UNIT
Laser modulation outputs: pins LA and LAQ						
I_O	modulation output current	note 7	3	–	60	mA
$I_{O(off)}$	output current during laser shutdown		–	–	10	μ A
V_O	output voltage		2	–	5	V
t_r	current rise time	note 8	–	120	300	ps
t_f	current fall time	note 8	–	120	300	ps
$J_{O(p-p)}$	intrinsic electrical output jitter (peak-to-peak value)	note 9	–	–	50	mUI
Bias current output: pin BIAS						
I_O	output current	note 10	2.5	–	90	mA
$I_{O(off)}$	output current during laser shutdown		–	–	10	μ A
$t_{res(off)}$	response time after laser shutdown	$I_{BIAS} = 90$ mA; note 11	–	–	1	μ s
V_O	output voltage		1	–	5	V
Alarm threshold inputs: pin ALARMHI and ALARMLO (on TZA3041AHL)						
$I_{ref(ALARMLO)}$	threshold reference current on pin ALARMLO	lower alarm; note 12	6	–	65	μ A
$V_{ref(ALARMLO)}$	optical reference voltage on pin ALARMLO	referenced to $V_{CC(R)}$	–1.55	–1.5	–1.45	V
$I_{ref(ALARMHI)}$	threshold reference current on pin ALARMHI	higher alarm; note 12	6	–	65	μ A
$V_{ref(ALARMHI)}$	optical reference voltage on pin ALARMHI	referenced to $V_{CC(R)}$	–1.55	–1.5	–1.45	V

Notes

- Remarks to the supply current:
 - The value for I_{CC} does not include the modulation and bias currents through pins LA, LAQ and BIAS.
 - Typical value for I_{CC} refers to, but does not include, $I_{MOD} = 30$ mA and $I_{BIAS} = 45$ mA.
 - The maximum value of I_{CC} refers to, but does not include, $I_{MOD} = 60$ mA and $I_{BIAS} = 90$ mA.
- Remarks to the power dissipation:
 - The value for P_{tot} includes the modulation and bias currents through pins LA, LAQ and BIAS.
 - The typical value for P_{tot} is the on-chip dissipation with $I_{MOD} = 30$ mA and $V_{LA} = V_{LAQ} = 2$ V, $I_{BIAS} = 45$ mA and $V_{BIAS} = 1$ V and typical process parameters.
 - The maximum value for P_{tot} is the on-chip dissipation with $I_{MOD} = 60$ mA and $V_{LA} = V_{LAQ} = 2$ V, $I_{BIAS} = 90$ mA and $V_{BIAS} = 1$ V and worst case process parameters.
- The minimum value of the capacitance on pin MONIN is required to prevent instability.
- The reference currents can be set using a resistor connected between pins ONE or ZERO and V_{CC} (see Section "Automatic laser control"). The corresponding ZERO level MPD current range is from 24 to 260 μ A. The ONE level MPD current range is from 96 to 1040 μ A.
- The specified transconductance is the ratio between the modulation current at pins LA or LAQ and the voltage at pin TONE, under small signal conditions.

Gigabit Ethernet/Fibre Channel laser drivers

TZA3041AHL; TZA3041BHL;
TZA3041U

6. The specified transconductance is the ratio between the biasing current at pin BIAS and the voltage at pin TZERO, under small signal conditions.
7. The values indicate the guaranteed interval, i.e. the lowest attainable output current is always lower than 3 mA and the highest output current always higher than 60 mA.
8. The voltage rise and fall times can be larger, due to capacitive effects. Specifications are guaranteed by design and characterization. Each device is tested at full operating speed to guarantee the RF functionality.
9. Measured in a frequency band from 250 kHz to 5 MHz, according to "ITU-T Recommendation G.813". The electrically generated (current) jitter is assumed to be less than 50% of the optical output jitter. The specification is guaranteed by design.
10. The values indicate the guaranteed interval, i.e. the lowest output current always is less than 2.5 mA and the highest output current is always more than 90 mA.
11. The response time is defined as the delay between the onset of the ramp on pin ALS (at 10% of the HIGH-level) and the extinction of the bias current (at 10% of the original value).
12. The reference currents can be set by using a resistor between $V_{CC(R)}$ and pins ALARMLO or ALARMHI; see Section "Bias alarm for TZA3041AHL" for detailed information. The corresponding range of low-bias thresholds is between 1.8 and 19.5 mA. The high-bias threshold range is from 9 to 97.5 mA.

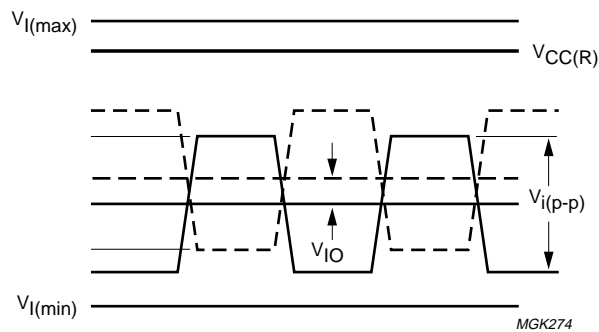
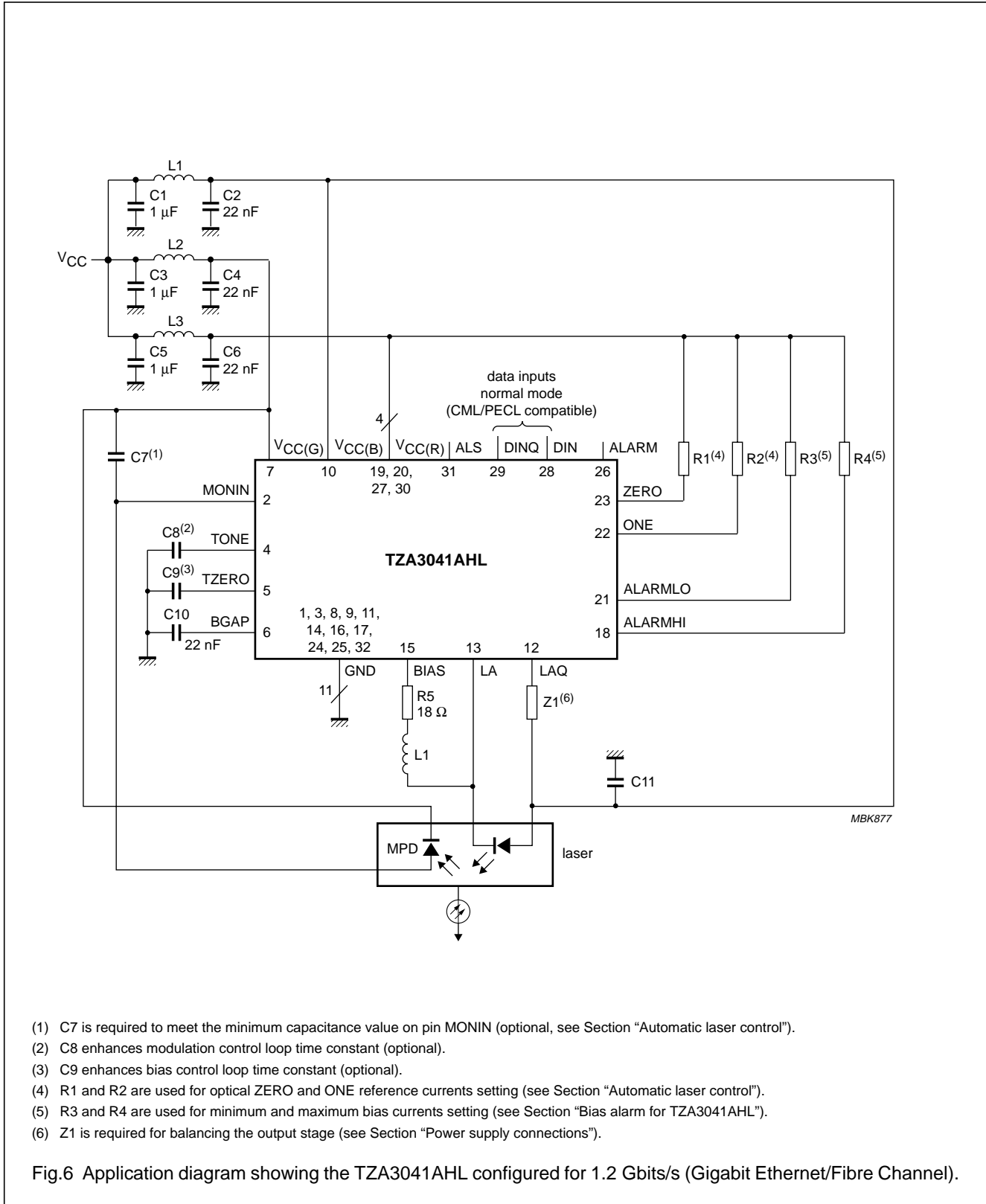

Fig.5 Logic level symbol definitions for data inputs.

Gigabit Ethernet/Fibre Channel
laser drivers

TZA3041AHL; TZA3041BHL;
TZA3041U

APPLICATION INFORMATION



Gigabit Ethernet/Fibre Channel
laser drivers

TZA3041AHL; TZA3041BHL;
TZA3041U

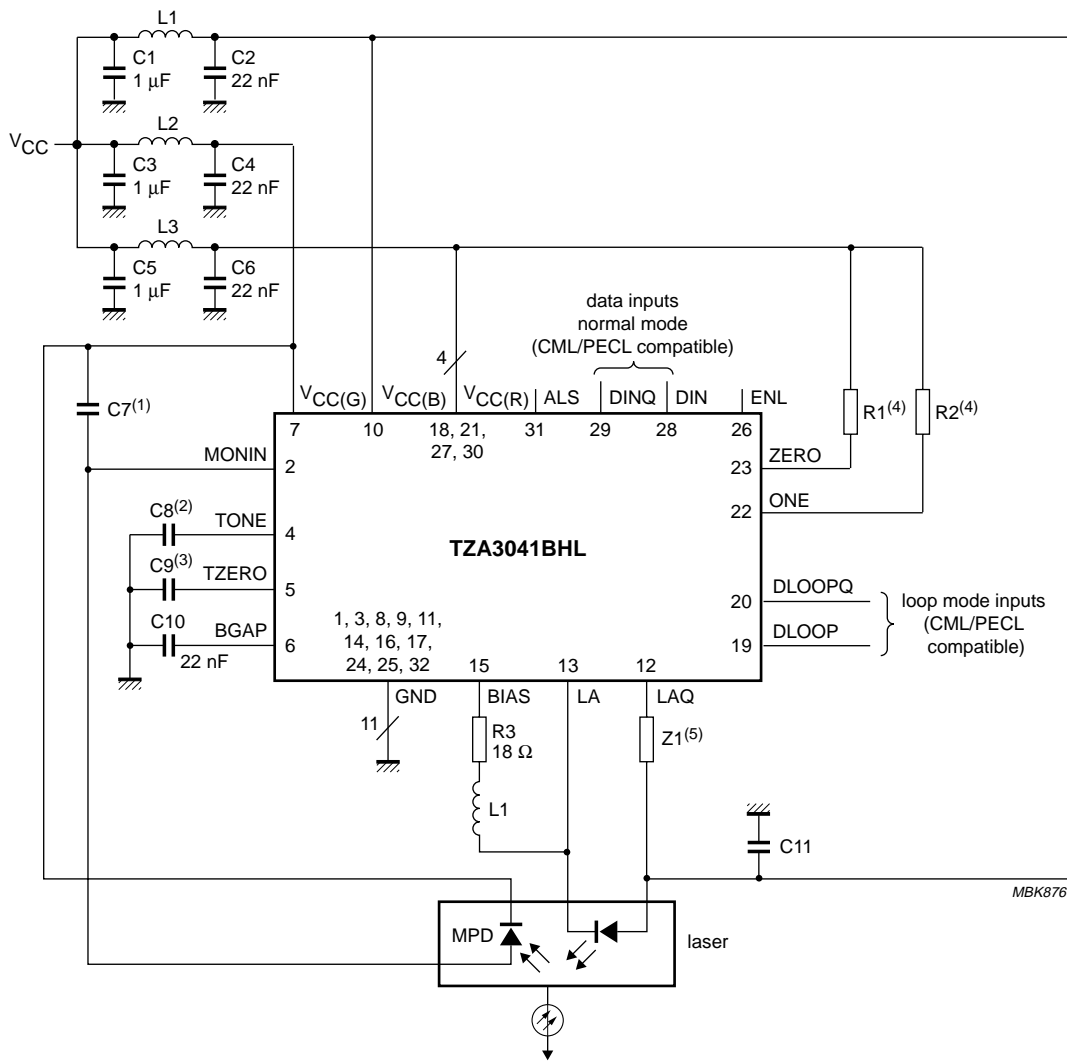

- (1) C7 is required to meet the minimum capacitance value on pin MONIN (optional, see Section "Automatic laser control").
- (2) C8 enhances modulation control loop time constant (optional).
- (3) C9 enhances bias control loop time constant (optional).
- (4) R1 and R2 are used for optical ZERO and ONE reference currents setting (see Section "Automatic laser control").
- (5) Z1 is required for balancing the output stage (see Section "Power supply connections").

Fig.7 Application diagram showing the TZA3041BHL configured for 1.2 Gbits/s (Gigabit Ethernet/Fibre Channel).

Gigabit Ethernet/Fibre Channel
laser driversTZA3041AHL; TZA3041BHL;
TZA3041U

BONDING PADS

SYMBOL	PAD	COORDINATES ⁽¹⁾	
		X	Y
GND	1	-664	-910
MONIN	2	-524	-910
GND	3	-367	-910
IGM	4	-227	-910
TONE	5	-70	-910
TZERO	6	+87	-910
BGAP	7	+244	-910
V _{CC(G)}	8	+384	-910
V _{CC(G)}	9	+524	-910
GND	10	+664	-910
GND	11	+910	-630
V _{CC(B)}	12	+910	-490
V _{CC(B)}	13	+910	-350
GND	14	+910	-210
LAQ	15	+910	-70
LA	16	+910	+70
GND	17	+910	+210
BIAS	18	+910	+350
GND	19	+910	+490
GND	20	+910	+630
GND	21	+681	+910
ALARMHI	22	+541	+910

SYMBOL	PAD	COORDINATES ⁽¹⁾	
		X	Y
V _{CC(R)}	23	+384	+910
DLOOP	24	+227	+910
DLOOPQ	25	+87	+910
V _{CC(R)}	26	-70	+910
ALARMLO	27	-210	+910
ONE	28	-367	+910
ZERO	29	-524	+910
GND	30	-681	+910
GND	31	-910	+681
ALARM	32	-910	+541
ENL	33	-910	+384
V _{CC(R)}	34	-910	+227
DIN	35	-910	+70
DINQ	36	-910	-70
V _{CC(R)}	37	-910	-227
ALS	38	-910	-367
GND	39	-910	-551
GND	40	-910	-664

Note

1. All x and y coordinates represent the position of the centre of the pad in μm with respect to the centre of the die (see Fig.8).

Gigabit Ethernet/Fibre Channel
laser drivers

TZA3041AHL; TZA3041BHL;
TZA3041U

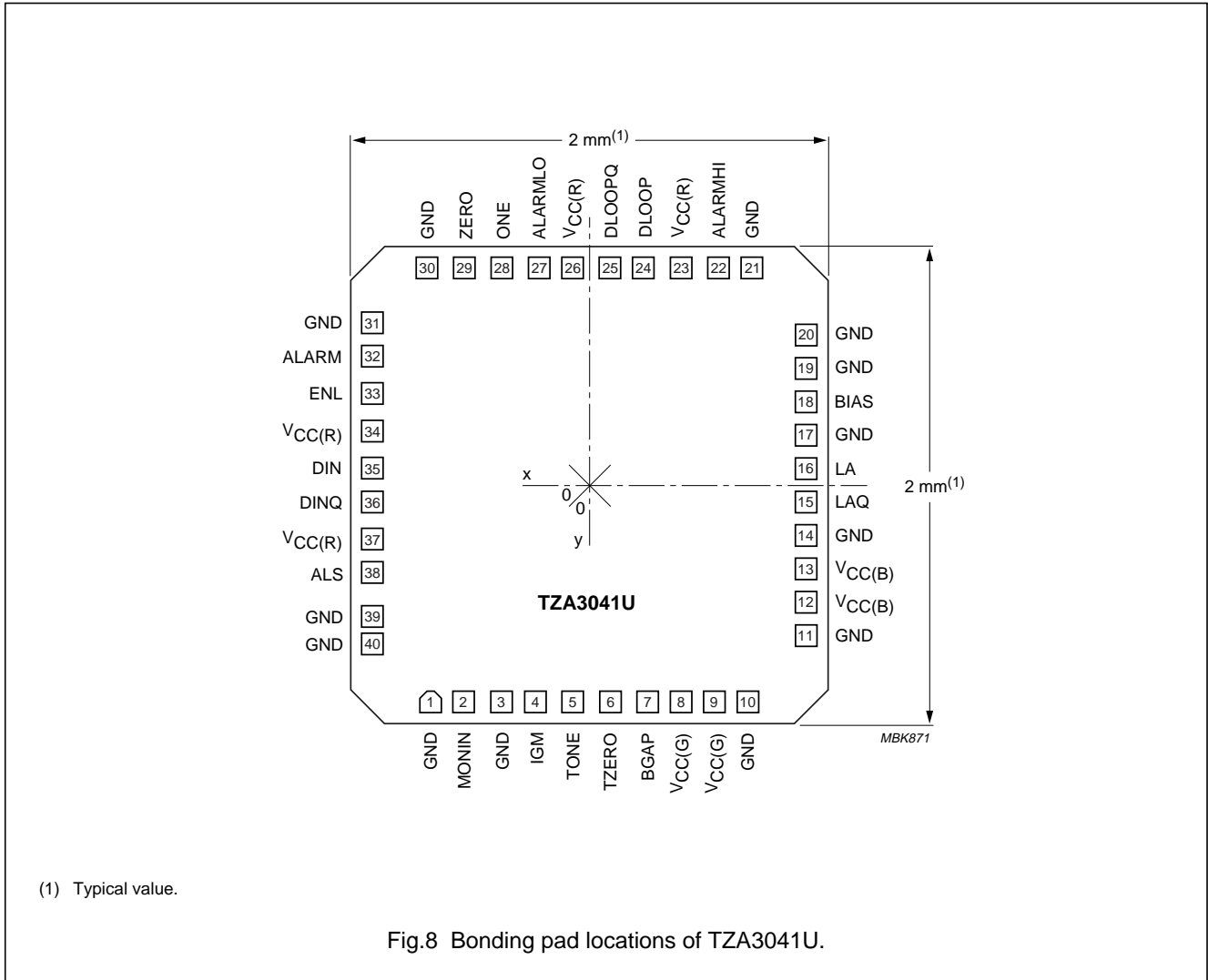

Table 1 Physical characteristics of bare die

PARAMETER	VALUE
Glass passivation	2.1 μm PSG (PhosphoSilicate Glass) on top of 0.7 μm silicon nitride
Bonding pad dimension	minimum dimension of exposed metallization is 90 × 90 μm (pad size = 100 × 100 μm)
Metallization	1.2 μm AlCu (1% Cu)
Thickness	380 μm nominal
Size	2.000 × 2.000 mm (4.000 mm ²)
Backing	silicon; electrically connected to GND potential through substrate contacts
Attache temperature	<430 °C; recommended die attache is glue
Attache time	<15 s

Gigabit Ethernet/Fibre Channel
laser drivers

TZA3041AHL; TZA3041BHL;
TZA3041U

PACKAGE OUTLINE

LQFP32: plastic low profile quad flat package; 32 leads; body 5 x 5 x 1.4 mm

SOT401-1

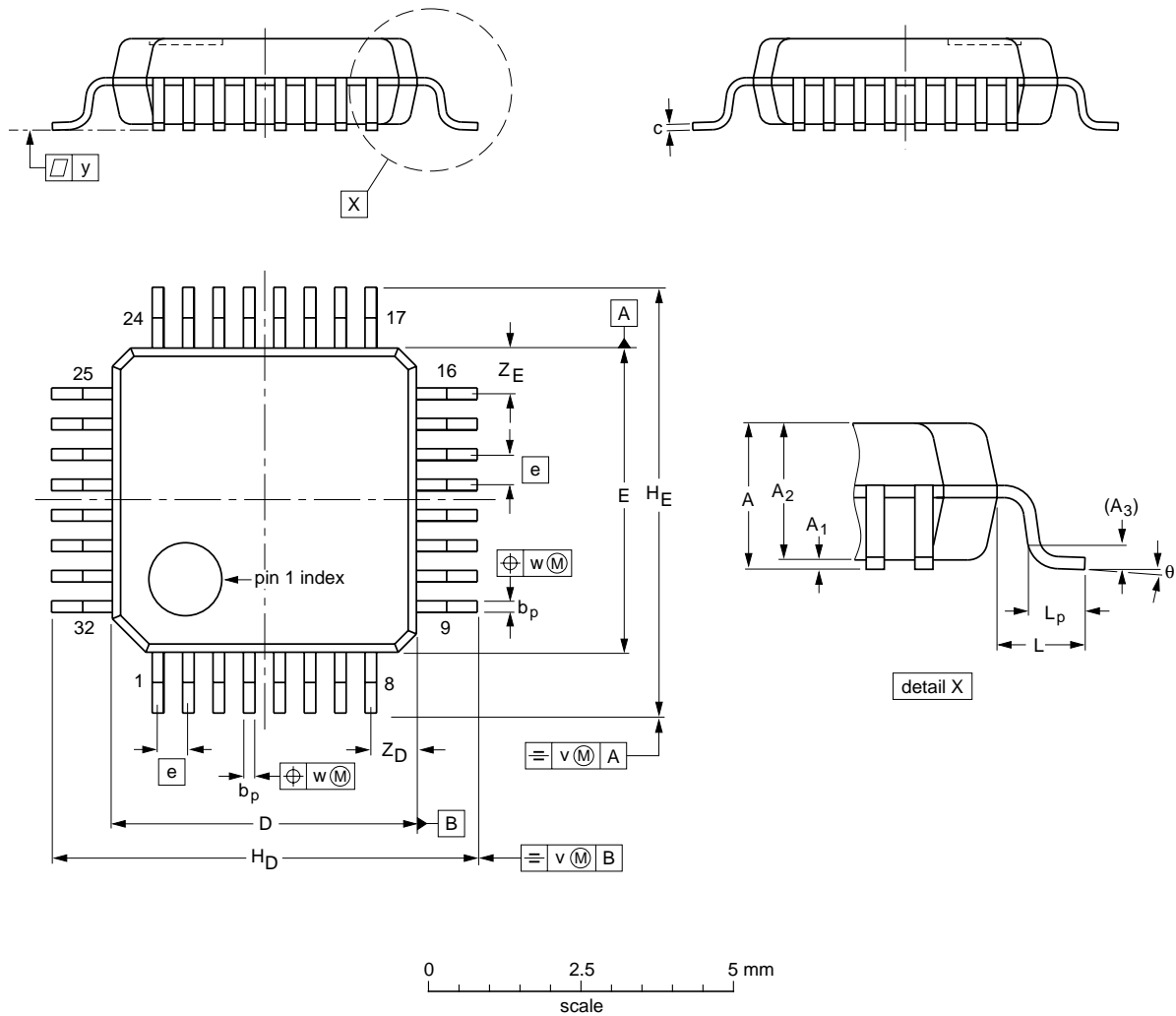

DIMENSIONS (mm are the original dimensions)

UNIT	A max.	A ₁	A ₂	A ₃	b _p	c	D ⁽¹⁾	E ⁽¹⁾	e	H _D	H _E	L	L _p	v	w	y	Z _D ⁽¹⁾	Z _E ⁽¹⁾	θ
mm	1.60	0.15 0.05	1.5 1.3	0.25	0.27 0.17	0.18 0.12	5.1 4.9	5.1 4.9	0.5	7.15 6.85	7.15 6.85	1.0	0.75 0.45	0.2	0.12	0.1	0.95 0.55	0.95 0.55	7° 0°

Note

1. Plastic or metal protrusions of 0.25 mm maximum per side are not included.

OUTLINE VERSION	REFERENCES				EUROPEAN PROJECTION	ISSUE DATE
	IEC	JEDEC	EIAJ			
SOT401-1						95-12-19 97-08-04

Gigabit Ethernet/Fibre Channel laser drivers

TZA3041AHL; TZA3041BHL;
TZA3041U

SOLDERING

Introduction to soldering surface mount packages

This text gives a very brief insight to a complex technology. A more in-depth account of soldering ICs can be found in our *"Data Handbook IC26; Integrated Circuit Packages"* (document order number 9398 652 90011).

There is no soldering method that is ideal for all surface mount IC packages. Wave soldering is not always suitable for surface mount ICs, or for printed-circuit boards with high population densities. In these situations reflow soldering is often used.

Reflow soldering

Reflow soldering requires solder paste (a suspension of fine solder particles, flux and binding agent) to be applied to the printed-circuit board by screen printing, stencilling or pressure-syringe dispensing before package placement.

Several methods exist for reflowing; for example, infrared/convection heating in a conveyor type oven. Throughput times (preheating, soldering and cooling) vary between 100 and 200 seconds depending on heating method.

Typical reflow peak temperatures range from 215 to 250 °C. The top-surface temperature of the packages should preferably be kept below 230 °C.

Wave soldering

Conventional single wave soldering is not recommended for surface mount devices () or printed-circuit boards with a high component density, as solder bridging and non-wetting can present major problems.

To overcome these problems the double-wave soldering method was specifically developed.

If wave soldering is used the following conditions must be observed for optimal results:

- Use a double-wave soldering method comprising a turbulent wave with high upward pressure followed by a smooth laminar wave.
- For packages with leads on two sides and a pitch (e):
 - larger than or equal to 1.27 mm, the footprint longitudinal axis is **preferred** to be parallel to the transport direction of the printed-circuit board;
 - smaller than 1.27 mm, the footprint longitudinal axis **must** be parallel to the transport direction of the printed-circuit board.

The footprint must incorporate solder thieves at the downstream end.

- For packages with leads on four sides, the footprint must be placed at a 45° angle to the transport direction of the printed-circuit board. The footprint must incorporate solder thieves downstream and at the side corners.

During placement and before soldering, the package must be fixed with a droplet of adhesive. The adhesive can be applied by screen printing, pin transfer or syringe dispensing. The package can be soldered after the adhesive is cured.

Typical dwell time is 4 seconds at 250 °C.

A mildly-activated flux will eliminate the need for removal of corrosive residues in most applications.

Manual soldering

Fix the component by first soldering two diagonally-opposite end leads. Use a low voltage (24 V or less) soldering iron applied to the flat part of the lead. Contact time must be limited to 10 seconds at up to 300 °C.

When using a dedicated tool, all other leads can be soldered in one operation within 2 to 5 seconds between 270 and 320 °C.

Gigabit Ethernet/Fibre Channel
laser drivers

TZA3041AHL; TZA3041BHL;
TZA3041U

Suitability of surface mount IC packages for wave and reflow soldering methods

PACKAGE	SOLDERING METHOD	
	WAVE	REFLOW ⁽¹⁾
BGA, SQFP	not suitable	suitable
HLQFP, HSQFP, HSOP, HTSSOP, SMS	not suitable ⁽²⁾	suitable
PLCC ⁽³⁾ , SO, SOJ	suitable	suitable
LQFP, QFP, TQFP	not recommended ⁽³⁾⁽⁴⁾	suitable
SSOP, TSSOP, VSO	not recommended ⁽⁵⁾	suitable

Notes

1. All surface mount (SMD) packages are moisture sensitive. Depending upon the moisture content, the maximum temperature (with respect to time) and body size of the package, there is a risk that internal or external package cracks may occur due to vaporization of the moisture in them (the so called popcorn effect). For details, refer to the Drypack information in the *"Data Handbook IC26; Integrated Circuit Packages; Section: Packing Methods"*.
2. These packages are not suitable for wave soldering as a solder joint between the printed-circuit board and heatsink (at bottom version) can not be achieved, and as solder may stick to the heatsink (on top version).
3. If wave soldering is considered, then the package must be placed at a 45° angle to the solder wave direction. The package footprint must incorporate solder thieves downstream and at the side corners.
4. Wave soldering is only suitable for LQFP, TQFP and QFP packages with a pitch (e) equal to or larger than 0.8 mm; it is definitely not suitable for packages with a pitch (e) equal to or smaller than 0.65 mm.
5. Wave soldering is only suitable for SSOP and TSSOP packages with a pitch (e) equal to or larger than 0.65 mm; it is definitely not suitable for packages with a pitch (e) equal to or smaller than 0.5 mm.

Gigabit Ethernet/Fibre Channel laser drivers

TZA3041AHL; TZA3041BHL;
TZA3041U

DEFINITIONS

Data sheet status	
Objective specification	This data sheet contains target or goal specifications for product development.
Preliminary specification	This data sheet contains preliminary data; supplementary data may be published later.
Product specification	This data sheet contains final product specifications.
Limiting values	
Limiting values given are in accordance with the Absolute Maximum Rating System (IEC 134). Stress above one or more of the limiting values may cause permanent damage to the device. These are stress ratings only and operation of the device at these or at any other conditions above those given in the Characteristics sections of the specification is not implied. Exposure to limiting values for extended periods may affect device reliability.	
Application information	
Where application information is given, it is advisory and does not form part of the specification.	

LIFE SUPPORT APPLICATIONS

These products are not designed for use in life support appliances, devices, or systems where malfunction of these products can reasonably be expected to result in personal injury. Philips customers using or selling these products for use in such applications do so at their own risk and agree to fully indemnify Philips for any damages resulting from such improper use or sale.

BARE DIE DISCLAIMER

All die are tested and are guaranteed to comply with all data sheet limits up to the point of wafer sawing for a period of ninety (90) days from the date of Philips' delivery. If there are data sheet limits not guaranteed, these will be separately indicated in the data sheet. There is no post wafer pack testing performed on individual die. Although the most modern processes are utilized for wafer sawing and die pick and place into wafer pack carriers, Philips Semiconductors has no control of third party procedures in the handling, packing or assembly of the die. Accordingly, Philips Semiconductors assumes no liability for device functionality or performance of the die or systems after handling, packing or assembly of the die. It is the responsibility of the customer to test and qualify their application in which the die is used.

Philips Semiconductors – a worldwide company

Argentina: see South America

Australia: 3 Figtree Drive, HOMEBUSH, NSW 2140,
Tel. +61 2 9704 8141, Fax. +61 2 9704 8139

Austria: Computerstr. 6, A-1101 WIEN, P.O. Box 213,
Tel. +43 1 60 101 1248, Fax. +43 1 60 101 1210

Belarus: Hotel Minsk Business Center, Bld. 3, r. 1211, Volodarski Str. 6,
220050 MINSK, Tel. +375 172 20 0733, Fax. +375 172 20 0773

Belgium: see The Netherlands

Brazil: see South America

Bulgaria: Philips Bulgaria Ltd., Energoproject, 15th floor,
51 James Bourchier Blvd., 1407 SOFIA,
Tel. +359 2 68 9211, Fax. +359 2 68 9102

Canada: PHILIPS SEMICONDUCTORS/COMPONENTS,
Tel. +1 800 234 7381, Fax. +1 800 943 0087

China/Hong Kong: 501 Hong Kong Industrial Technology Centre,
72 Tat Chee Avenue, Kowloon Tong, HONG KONG,
Tel. +852 2319 7888, Fax. +852 2319 7700

Colombia: see South America

Czech Republic: see Austria

Denmark: Sydhavnsgade 23, 1780 COPENHAGEN V,
Tel. +45 33 29 3333, Fax. +45 33 29 3905

Finland: Sinikalliontie 3, FIN-02630 ESPOO,
Tel. +358 9 615 800, Fax. +358 9 6158 0920

France: 51 Rue Carnot, BP317, 92156 SURESNES Cedex,
Tel. +33 1 4099 6161, Fax. +33 1 4099 6427

Germany: Hammerbrookstraße 69, D-20097 HAMBURG,
Tel. +49 40 2353 60, Fax. +49 40 2353 6300

Hungary: see Austria

India: Philips INDIA Ltd, Band Box Building, 2nd floor,
254-D, Dr. Annie Besant Road, Worli, MUMBAI 400 025,
Tel. +91 22 493 8541, Fax. +91 22 493 0966

Indonesia: PT Philips Development Corporation, Semiconductors Division,
Gedung Philips, Jl. Buncit Raya Kav.99-100, JAKARTA 12510,
Tel. +62 21 794 0040 ext. 2501, Fax. +62 21 794 0080

Ireland: Newstead, Clonskeagh, DUBLIN 14,
Tel. +353 1 7640 000, Fax. +353 1 7640 200

Israel: RAPAC Electronics, 7 Kehilat Saloniki St, PO Box 18053,
TEL AVIV 61180, Tel. +972 3 645 0444, Fax. +972 3 649 1007

Italy: PHILIPS SEMICONDUCTORS, Via Casati, 23 - 20052 MONZA (MI),
Tel. +39 039 203 6838, Fax +39 039 203 6800

Japan: Philips Bldg 13-37, Kohnan 2-chome, Minato-ku,
TOKYO 108-8507, Tel. +81 3 3740 5130, Fax. +81 3 3740 5057

Korea: Philips House, 260-199 Itaewon-dong, Yongsan-ku, SEOUL,
Tel. +82 2 709 1412, Fax. +82 2 709 1415

Malaysia: No. 76 Jalan Universiti, 46200 PETALING JAYA, SELANGOR,
Tel. +60 3 750 5214, Fax. +60 3 757 4880

Mexico: 5900 Gateway East, Suite 200, EL PASO, TEXAS 79905,
Tel. +9-5 800 234 7381, Fax +9-5 800 943 0087

Middle East: see Italy

Netherlands: Postbus 90050, 5600 PB EINDHOVEN, Bldg. VB,
Tel. +31 40 27 82785, Fax. +31 40 27 88399

New Zealand: 2 Wagener Place, C.P.O. Box 1041, AUCKLAND,
Tel. +64 9 849 4160, Fax. +64 9 849 7811

Norway: Box 1, Manglerud 0612, OSLO,
Tel. +47 22 74 8000, Fax. +47 22 74 8341

Pakistan: see Singapore

Philippines: Philips Semiconductors Philippines Inc.,
106 Valero St. Salcedo Village, P.O. Box 2108 MCC, MAKATI,
Metro MANILA, Tel. +63 2 816 6380, Fax. +63 2 817 3474

Poland: Ul. Lukiska 10, PL 04-123 WARSZAWA,
Tel. +48 22 612 2831, Fax. +48 22 612 2327

Portugal: see Spain

Romania: see Italy

Russia: Philips Russia, Ul. Usatcheva 35A, 119048 MOSCOW,
Tel. +7 095 755 6918, Fax. +7 095 755 6919

Singapore: Lorong 1, Toa Payoh, SINGAPORE 319762,
Tel. +65 350 2538, Fax. +65 251 6500

Slovakia: see Austria

Slovenia: see Italy

South Africa: S.A. PHILIPS Pty Ltd., 195-215 Main Road Martindale,
2092 JOHANNESBURG, P.O. Box 58088 Newville 2114,
Tel. +27 11 471 5401, Fax. +27 11 471 5398

South America: Al. Vicente Pinzon, 173, 6th floor,
04547-130 SÃO PAULO, SP, Brazil,
Tel. +55 11 821 2333, Fax. +55 11 821 2382

Spain: Balmes 22, 08007 BARCELONA,
Tel. +34 93 301 6312, Fax. +34 93 301 4107

Sweden: Kottbygatan 7, Akalla, S-16485 STOCKHOLM,
Tel. +46 8 5985 2000, Fax. +46 8 5985 2745

Switzerland: Allmendstrasse 140, CH-8027 ZÜRICH,
Tel. +41 1 488 2741 Fax. +41 1 488 3263

Taiwan: Philips Semiconductors, 6F, No. 96, Chien Kuo N. Rd., Sec. 1,
TAIPEI, Taiwan Tel. +886 2 2134 2886, Fax. +886 2 2134 2874

Thailand: PHILIPS ELECTRONICS (THAILAND) Ltd.,
209/2 Sanpavuth-Bangna Road Prakanong, BANGKOK 10260,
Tel. +66 2 745 4090, Fax. +66 2 398 0793

Turkey: Yukari Dudullu, Org. San. Blg., 2.Cad. Nr. 28 81260 Umraniye,
ISTANBUL, Tel. +90 216 522 1500, Fax. +90 216 522 1813

Ukraine: PHILIPS UKRAINE, 4 Patrice Lumumba str., Building B, Floor 7,
252042 KIEV, Tel. +380 44 264 2776, Fax. +380 44 268 0461

United Kingdom: Philips Semiconductors Ltd., 276 Bath Road, Hayes,
MIDDLESEX UB3 5BX, Tel. +44 208 730 5000, Fax. +44 208 754 8421

United States: 811 East Arques Avenue, SUNNYVALE, CA 94088-3409,
Tel. +1 800 234 7381, Fax. +1 800 943 0087

Uruguay: see South America

Vietnam: see Singapore

Yugoslavia: PHILIPS, Trg N. Pasica 5/v, 11000 BEOGRAD,
Tel. +381 11 62 5344, Fax.+381 11 63 5777

For all other countries apply to: Philips Semiconductors,
International Marketing & Sales Communications, Building BE-p, P.O. Box 218,
5600 MD EINDHOVEN, The Netherlands, Fax. +31 40 27 24825

Internet: <http://www.semiconductors.philips.com>

© Philips Electronics N.V. 1999

SCA 67

All rights are reserved. Reproduction in whole or in part is prohibited without the prior written consent of the copyright owner.

The information presented in this document does not form part of any quotation or contract, is believed to be accurate and reliable and may be changed without notice. No liability will be accepted by the publisher for any consequence of its use. Publication thereof does not convey nor imply any license under patent- or other industrial or intellectual property rights.

Printed in The Netherlands

465012/02/pp24

Date of release: 1999 Aug 24

Document order number: 9397 750 05284

Let's make things better.

**Philips
Semiconductors**



PHILIPS