

Digital I/Q-Generator Chip for DAB

Description

The U2752M is an integrated circuit in CMOS technology for splitting a digital DAB signal into its quadrature components. The device is designed for DAB (ETS 300 401) applications.

Electrostatic sensitive device.
Observe precautions for handling.



Features

- U2752M splits a digital DAB input signal into its quadrature components
- Quadrature matching: 0 dB in magnitude, $\leq 1.6^\circ$ in phase
- Clock frequency: 4.096 MHz
- Input signal
 - Center frequency: 3.072 MHz
 - Bandwidth: 1.536 MHz
 - Data format: 8 bit, 4.096 MHz in 2's complement representation
- Output signal
 - Select pin for baseband or 1.024-MHz center frequency
 - I-, Q- components in time multiplex
 - Data format: 8 bit, 4.096 MHz in 2's complement representation

Block Diagram

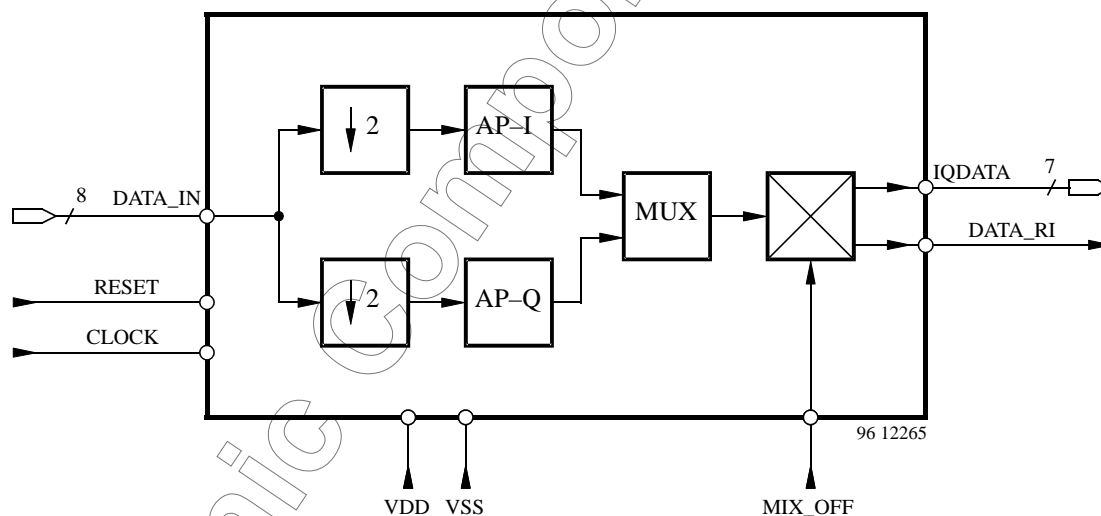

Figure 1. Block diagram

Ordering Information

Extended Type Number	Package	Remarks
U2752M-AFL	SO24	
U2752M-AFLG3	SO24	Taping according to IEC-286-3

Pin Description

Pin	Signal	Description	PAD Type
1	MIX_OFF	Low: I/Q in baseband representation, High: I/Q in IF representation	BUFINCDN
2	RESET	Reset signal, high active	BUFINCDN
3	VSS	Ground	
4	DATA_IN0	Data input (LSB)	BUFINMOS
5	DATA_IN1	Data input	BUFINMOS
6	DATA_IN2	Data input	BUFINMOS
7	DATA_IN3	Data input	BUFINMOS
8	DATA_IN4	Data input	BUFINMOS
9	DATA_IN5	Data input	BUFINMOS
10	DATA_IN6	Data input	BUFINMOS
11	DATA_IN7	Data input (MSB)	BUFINMOS
12	VSS	Ground	
13	CLOCK	System clock 4.096 MHz	BUFTGMOS
14	DATA_RI	Internal data_ri signal	BU2OUT
15	VDD	Power supply	
16	IQDATA7	Data_output, I and Q multiplex (MSB)	BU2OUT
17	IQDATA6	Data_output, I and Q multiplex	BU2OUT
18	IQDATA5	Data_output, I and Q multiplex	BU2OUT
19	IQDATA4	Data_output, I and Q multiplex	BU2OUT
20	IQDATA3	Data_output, I and Q multiplex	BU2OUT
21	IQDATA2	Data_output, I and Q multiplex	BU2OUT
22	IQDATA1	Data_output, I and Q multiplex	BU2OUT
23	IQDATA0	Data_output, I and Q multiplex (LSB)	BU2OUT
24	VDD	Power supply	

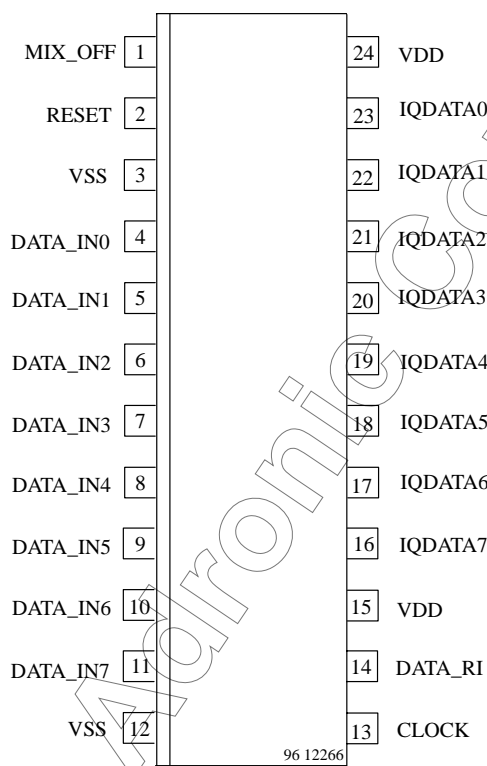

Figure 2. Pinning

Functional Description

The U2752M generates the in-phase and quadrature components of the DAB input signal with a quadrature matching of 0 dB in magnitude and a maximum value of 1.6° in phase. The clock of the device is 4.096 MHz.

The data format of the input signal DATA_IN is 8 bits, sampled with 4.096 MHz in 2's complement representation. Its center frequency is 3.072 MHz with a bandwidth of 1536 MHz. The U2752M uses decimation and common filter techniques to generate the quadrature components.

The output interface consists of the split signal IQDATA with a data format of 8 bits, 4.096 MHz in 2's complement representation. The in-phase (I) and quadrature (Q) components are represented in time division multiplex format with a selection signal DATA_RI of 4.096 MHz. The output representation in baseband or 1.024-MHz center frequency is selected by the MIX_OFF signal. For utilization together with TEMIC's U2752M device, the baseband representation (MIX_OFF = '0') must be selected.

Absolute Maximum Ratings

Parameters	Symbol	Min.	Typ.	Max.	Unit
DC supply voltage	V_{DD}	-0.5		+7	V
Input / output voltage	V_{in}/V_{out}	-0.5		$V_{DD} + 0.5$	V
Storage temperature	T_{stg}	-65		+150	°C

Operating Range

Parameters	Symbol	Min.	Typ.	Max.	Unit
DC supply voltage	V_{DD}	4.5		5.5	V
Input / output voltage	V_{in}/V_{out}	0		V_{DD}	V
Ambient temperature	T_{amb}	-40		+85	°C
Power dissipation (static)	P_{stat}		0.25		mW
Power dissipation (dynamic)	P_{dyn}		15		mW

Thermal Resistance

Parameters	Symbol	Value	Unit
Junction ambient SO24	R_{thJA}	80	K/W

Electrical Characteristics

Test conditions: $V_{DD} = 5\text{ V}$, $T_{amb} = 25^\circ\text{C}$

Parameters	Test Conditions / Pins	Symbol	Min.	Typ.	Max.	Unit
Input HIGH voltage	Pins 1, 2, 4 to 11	V_{IH}	3.5			V
Input LOW voltage	Pins 1, 2, 4 to 11	V_{IL}			1.5	V
Positive threshold	Pin 13	V_{T+}	1.61		2.60	V
Negative threshold	Pin 13	V_{T-}	2.47		3.52	V
Input leakage	$V_{IN} = V_{DD}$ or V_{SS} $V_{IN} \neq V_{DD}$ Pins 1, 2, 4 to 11 and 13	I_L		± 1 +40	± 5 +100	μA μA
Output HIGH voltage	$I_{OH} = +6.4\text{ mA}$ Pins 14, 16 to 23	V_{OH}	2.4			V
Output LOW voltage	$I_{OH} = -6.4\text{ mA}$ Pins 14, 16 to 23	V_{OL}			0.4	V

Input Interface Description

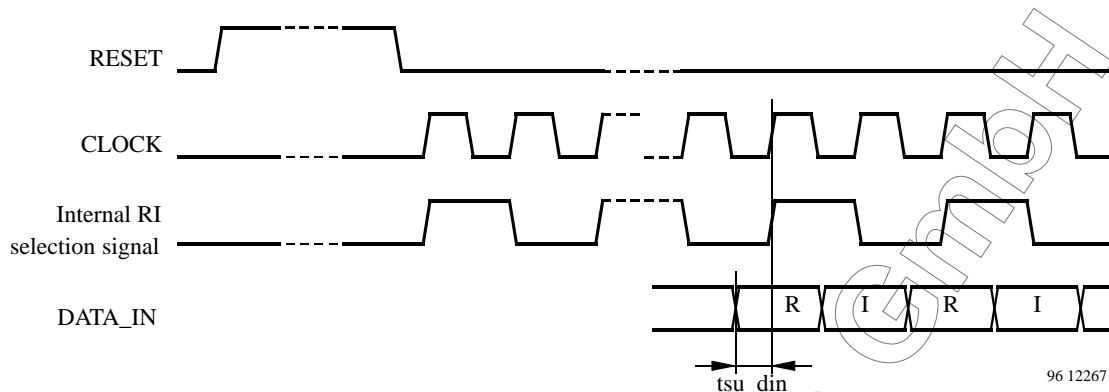

Figure 3. Input interface signals ($tsu_din \geq 10\text{ ns}$)

For verification purposes, it can be helpful to know how the U2752M selects the input samples for real and imaginary data processing.

The U2752M generates an internal real and imaginary selection signal, which depends on the first recognized rising CLOCK edge as shown in figure 3. Due to this selection signal, the data input DATA_IN will be used for the real or imaginary process path of the IC. The setup time of DATA_IN tsu_din must be $\geq 10\text{ ns}$.

Results

The phase deviation from 90° of the I- and Q- parts over the normalized frequency is shown in figure 4.

The DAB-relevant frequency range is from $1/8$ to $7/8$ on the normalized frequency axis.

For the DAB frequency range, the maximum phase mismatch is 1.6° and the amplitude mismatch is 0 dB.

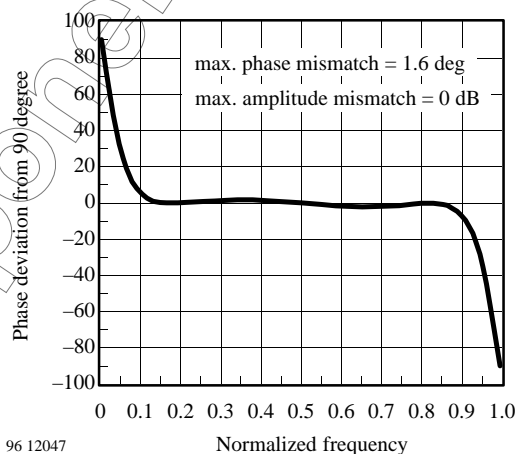
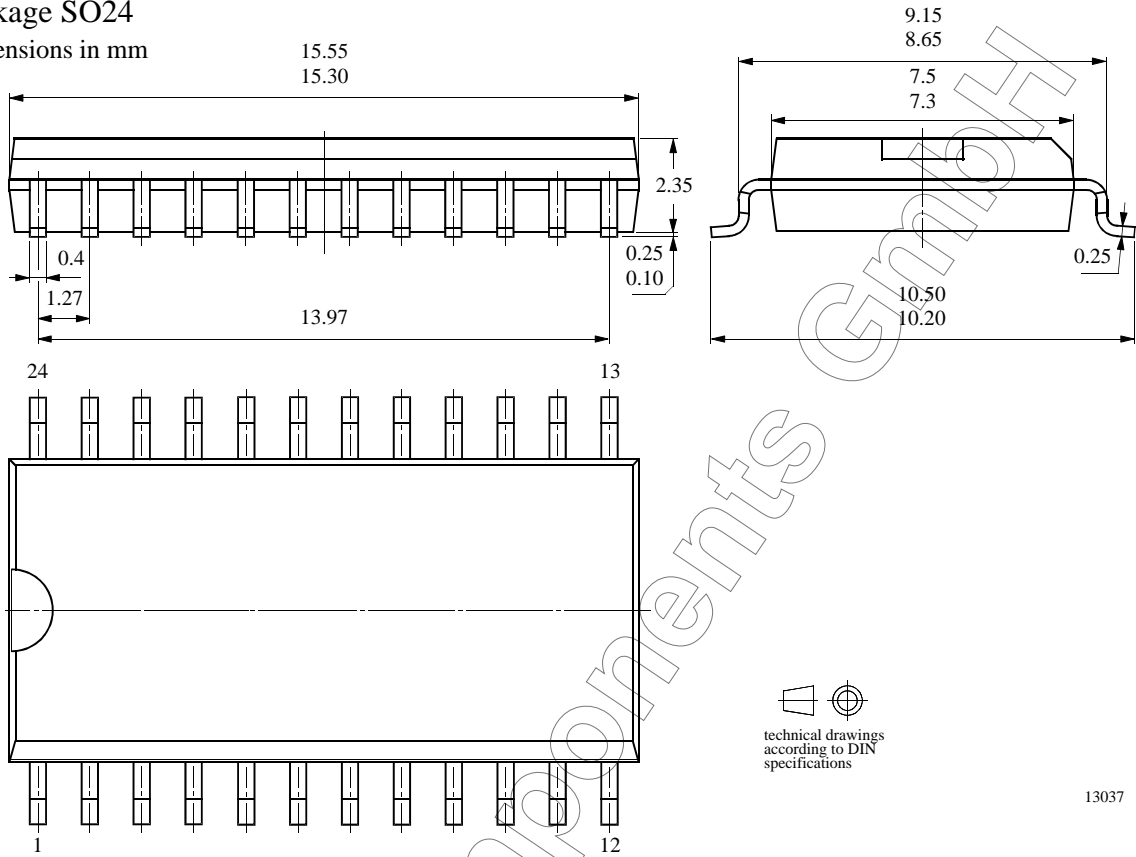

Figure 4. Phase deviation of the I- and Q-parts

Package Information

Package SO24

Dimensions in mm



13037

Ozone Depleting Substances Policy Statement

It is the policy of **TEMIC Semiconductor GmbH** to

1. Meet all present and future national and international statutory requirements.
2. Regularly and continuously improve the performance of our products, processes, distribution and operating systems with respect to their impact on the health and safety of our employees and the public, as well as their impact on the environment.

It is particular concern to control or eliminate releases of those substances into the atmosphere which are known as ozone depleting substances (ODSs).

The Montreal Protocol (1987) and its London Amendments (1990) intend to severely restrict the use of ODSs and forbid their use within the next ten years. Various national and international initiatives are pressing for an earlier ban on these substances.

TEMIC Semiconductor GmbH has been able to use its policy of continuous improvements to eliminate the use of ODSs listed in the following documents.

1. Annex A, B and list of transitional substances of the Montreal Protocol and the London Amendments respectively
2. Class I and II ozone depleting substances in the Clean Air Act Amendments of 1990 by the Environmental Protection Agency (EPA) in the USA
3. Council Decision 88/540/EEC and 91/690/EEC Annex A, B and C (transitional substances) respectively.

TEMIC Semiconductor GmbH can certify that our semiconductors are not manufactured with ozone depleting substances and do not contain such substances.

We reserve the right to make changes to improve technical design and may do so without further notice.

Parameters can vary in different applications. All operating parameters must be validated for each customer application by the customer. Should the buyer use TEMIC products for any unintended or unauthorized application, the buyer shall indemnify TEMIC against all claims, costs, damages, and expenses, arising out of, directly or indirectly, any claim of personal damage, injury or death associated with such unintended or unauthorized use.

TEMIC Semiconductor GmbH, P.O.B. 3535, D-74025 Heilbronn, Germany
Telephone: 49 (0)7131 67 2831, Fax number: 49 (0)7131 67 2423