

POWER DARLINGTONS

10 Amp, 150V, Planar NPN

U2T101
U2T105
U2T201
U2T205

FEATURES

- High Current Gain: up to 2000 min @ $I_C = 5A$
- Low Saturation Voltage: as low as 1.5V max @ $I_C = 5A$
- High Voltage: up to 150V min V_{CER}
- Monolithic Design Incorporating Multiple-Emitter Techniques
- Triple-Diffused Planar Construction

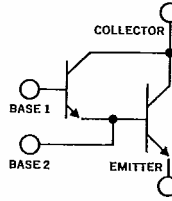

DESCRIPTION

Unitrode NPN Darlington's consist of a two transistor circuit on a single monolithic planar chip.

7-33-29

ABSOLUTE MAXIMUM RATINGS

	TO-33		3 PIN TO-66	
	U2T101	U2T105	U2T201	U2T205
Collector-Emitter Voltage	80V	150V	80V	150V
Emitter Base Voltages,				
V_{EB2}	6V	6V	6V	6V
V_{EB1}	12V	12V	12V	12V
D.C. Collector Current	5A	5A	5A	5A
Peak Collector Current	10A	10A	10A	10A
Base 1 Current	0.5A	0.5A	0.5A	0.5A
Power Dissipation				
25°C Ambient	1W	1W	2.5W	2.5W
100°C Case	5W	5W	25W	25W
Thermal Resistance, Junction to Case	20°C/W		4°C/W	
Operating and Storage Temperature Range	-65°C to 200°C		-65°C to 200°C	

8

MECHANICAL SPECIFICATIONS

U2T101 U2T105

	ins	mm
A	305-335	7.75-8.51
B	335-370	8.51-9.40
C	240-260	6.10-6.60
D	0.17 ± 0.02	4.32 ± 0.51
E	1.5 MIN	38.10 MIN
F	0.18 MAX	0.46 MAX
G	0.31 ± 0.03	0.79 ± 0.08
H	200	1.02
J	100	2.54
K	0.29-0.45	0.74-1.14
L	100	2.54

COLLECTOR CONNECTED TO CASE

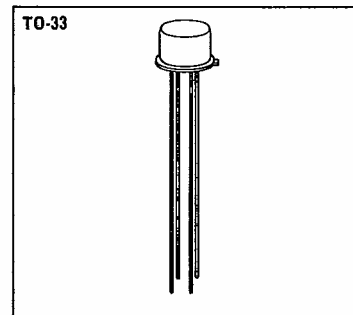

U2T201 U2T205

	ins	mm
A	250-340	6.35-8.64
B	620 MAX	15.75 MAX
C	0.50-0.75	1.27-1.91
D	0.28-0.34	0.71-0.86
E	360 MIN	9.14 MIN
F	958-962	24.33-24.43
G	1.90-2.10	4.83-5.33
H	1.90-2.10	4.83-5.33
J	350 MAX RAD	8.89 MAX RAD
K	570-590	14.48-14.99
L	142-152	3.61-3.86
M	145 MAX RAD	3.68 MAX RAD

COLLECTOR CONNECTED TO CASE

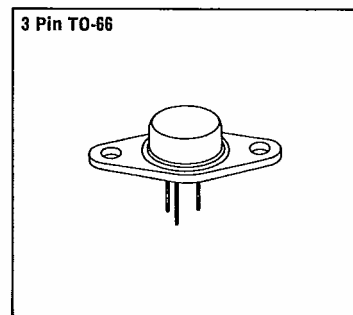

ELECTRICAL SPECIFICATIONS (at 25°C unless noted)

T-33-29
Test Conditions

Test	Symbol	U2T101 & U2T201		U2T105 & U2T205		Units	Test Conditions
		Min.	Max.	Min.	Max.		
D.C. Current Gain (Note 1)	h_{FE}	2000	—	1000	—	—	$I_C = 1.0A, V_{CE} = 2V, R_{B2E} = 1K$
D.C. Current Gain (Note 1)	h_{FE}	2000	—	1000	—	—	$I_C = 5A, V_{CE} = 5V, R_{B2E} = 100$
Collector Saturation Voltage (Note 1)	$V_{CE(sat)}$	—	1.5	—	2.5	V	$I_C = 5A, R_{B2E} = 100$ U2T101, 201: $I_{B1} = 5mA$ U2T105, 205: $I_{B1} = 10mA$
Collector-Emitter Breakdown Voltage (Note 1)	BV_{CER}	80	—	150	—	V	$I_C = 25mA, R_{B1E} = 2.2K, R_{B2E} = 100$
Collector Cutoff Current	I_{CER}	—	1.0	—	1.0	μA	$R_{B1E} = 2.2K, R_{B2E} = 100$ U2T101, 201: $V_{CE} = 80V$ U2T105, 205: $V_{CE} = 150V$
Collector Cutoff Current	I_{CER}	—	1.0	—	1.0	mA	$R_{B1E} = 2.2K, R_{B2E} = 100, T = 150^\circ C$ U2T101, 201: $V_{CE} = 80V$ U2T105, 205: $V_{CE} = 150V$
Collector Capacitance	C_{obo}	—	100	—	100	pf	$V_{CB1} = 10, I_E = 0, f = 1MHz$
A.C. Current Gain	h_{fe}	5	—	5	—	—	$I_C = 1.0A, V_{CE} = 10V, f = 10MHz, R_{B2E} = 100$
Switching Speeds	Delay Time	t_d	100 Typ.	100 Typ.	ns	$V_{CC} = 30V,$ $I_C = 5A,$ U2T101, 201: $I_B(ON) = I_B(OFF) = 5mA,$ U2T105, 205: $I_B(ON) = I_B(OFF) = 10mA,$ $R_{B2E} = 100$	
	Rise Time	t_r	300 Typ.	400 Typ.	ns		
	Storage Time	t_s	600 Typ.	500 Typ.	ns		
	Fall Time	t_f	500 Typ.	500 Typ.	ns		

Note: 1. Pulse width = 300 μs ; duty cycle $\leq 2\%$.

Maximum Safe Operating Area U2T101 & 105

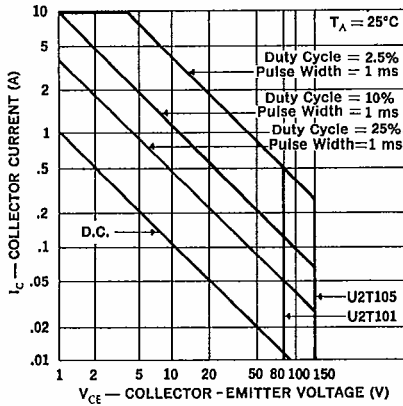

Maximum Safe Operating Area U2T201 & 205

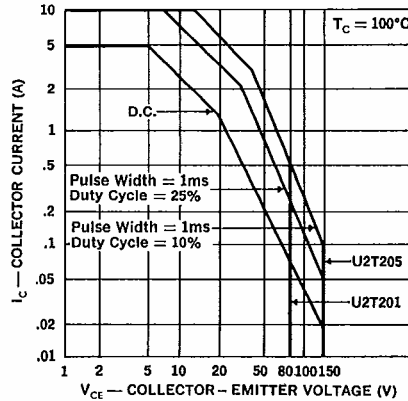

D.C. Current Gain vs. Collector Current U2T101, U2T105, U2T201, U2T205

