

POWER DARLINGTONS

3 Amp, 100V, Planar NPN, Plastic

U2TA506
U2TA508
U2TA510

T-35-29

FEATURES

- High Current Gain: 500 min. @ $I_C = 3A$
- Low Saturation Voltage: as low as 1.5V max. @ $I_C = 3A$
- Economic Plastic Molded Construction

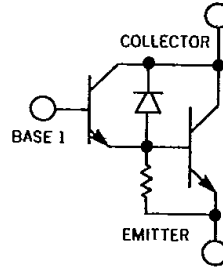

DESCRIPTION

Unitrode NPN Darlington consists of a two transistor circuit on a single monolithic planar chip, including integral bias resistance and protective diode. It is ideally suited for pulse power applications in power supplies, printers, solid state relays and displays.

ABSOLUTE MAXIMUM RATINGS

	U2TA506	U2TA508	U2TA510
Collector-Base Voltage, V_{CBO}	80V	100V	120V
Collector-Emitter Voltage, V_{CEO}	60V	80V	100V
Emitter-Base Voltage, V_{EBO}		5V	
D.C. Collector Current, I_C		.75A	
Peak Collector Current, I_C		5A	
Base Current, I_B		.6A	
Power Dissipation			
25°C Case		2.2W	
25°C Ambient		871mW	
Thermal Resistance, θ_{J-C}		62.5°C/W	
Thermal Resistance, θ_{J-A}		155°C/W	
Storage Temperature Range		-55 to +150°C	
Maximum Junction Temperature		+175°C	

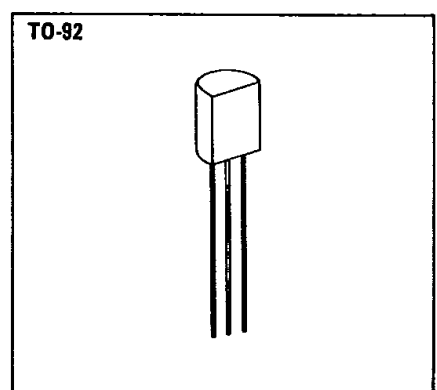
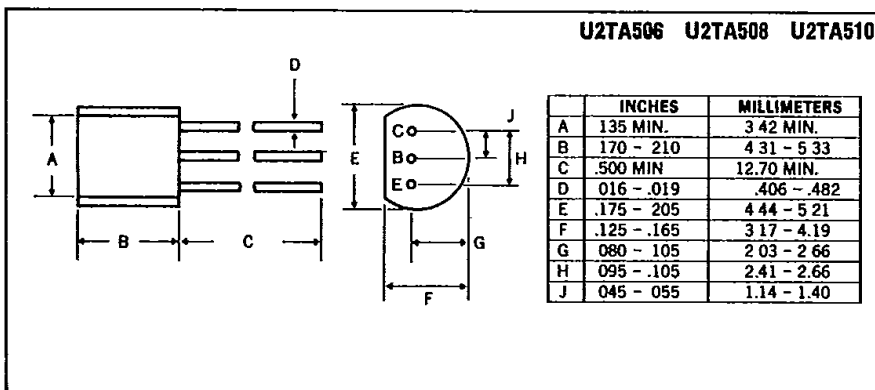

ELECTRICAL SPECIFICATIONS (at 25°C unless noted)

T-35-29

Test	Symbol	Min.	Max.	Units	Test Conditions
D.C. Current Gain (Note 1)	h_{FE}	1000	—	—	$I_C = 1A, V_{CE} = 5Vdc$
D.C. Current Gain (Note 1)	h_{FE}	500	—	—	$I_C = 3A, V_{CE} = 5Vdc$
D.C. Current Gain (Note 1)	h_{FE}	300 Typ.		—	$I_C = 5A, V_{CE} = 5Vdc$
Collector Saturation Voltage (Note 1)	$V_{CE(sat)}$	—	1.5	Vdc	$I_C = 3A, I_B = 30mA$
Collector-Emitter Breakdown Voltage (Note 1)	BV_{CEO}			Vdc	$I_C = 10mA$
U2TA506		60	—		
U2TA508		80	—		
U2TA510		100	—		
Collector-Emitter Cutoff Current	I_{CER}	—	10	μA dc	$V_{CE} = \text{rating}, R = 100\Omega$
Collector-Emitter Cutoff Current	I_{CER}	—	1	mAdc	$V_{CE} = \text{rating}, R = 100\Omega, T_A = 125^\circ C$
Emitter-Base Cutoff Current	I_{EBO}	—	50	μA dc	$V_{EB} = 5Vdc$
Output Capacitance	C_{ob}	—	50	pf	$V_{CB} = 10Vdc, I_E = 0, f = 1MHz$
A.C. Current Gain	h_{fe}	4.0 Typ.		—	$I_C = 1Adc, V_{CE} = 5Vdc, f = 10MHz$
Rise Time	t_r	600 Typ.		ns	$I_C = 2A$
Storage Time	t_s	1500 Typ.		ns	$V_{CC} = \text{rating}, I_{B(on)} = I_{B(off)} = 4mA$
Fall Time	t_f	800 Typ.		ns	

Note 1: Pulse width = 300 μ s; duty cycle \leq 2%.

Note 2: For thermal considerations for operating U2TA506, U2TA508 and U2TA510, refer to Application Note U-77.

Maximum Safe Operating Area
U2TA506, 508 & 510

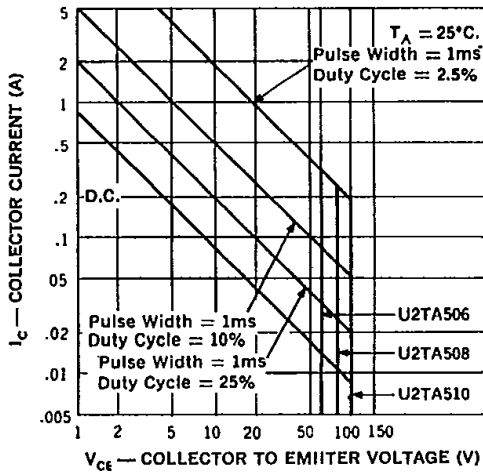

D.C. Current Gain vs. Collector Current

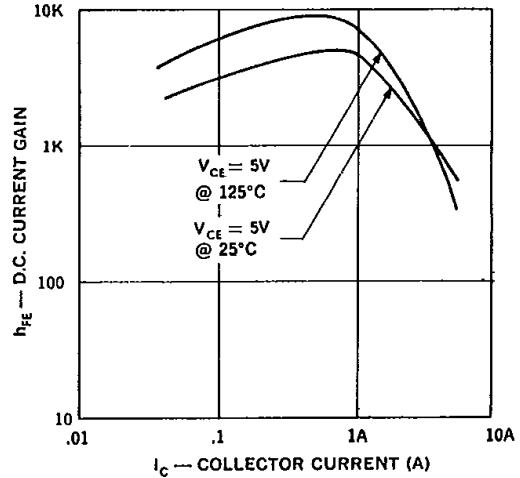

Saturation Voltage vs Base Current

