Low Voltage Standard Telephone Circuit with 13 Memories

Description

TEMIC's low voltage telephone circuit, U3761MB performs all the speech and line interface functions required in an electronic telephone set, the tone ringer, the pulse and DTMF dialing with redial, notice function, and 13 memories.

Features

Speech Circuit

- Adjustable DC characteristic
- Symmetrical input of microphone amplifier
- Receiving amplifier for dynamic or piezo-electric earpieces
- Automatic line loss compensation
- Last number redial up to 32 digits
- Three by 32 digits direct (one touch) memory
- Ten by 16 digits indirect (two touch) memory
- Notice function up to 32 digits
- Standard low-cost crystal 3.57 MHz or ceramic resonator

Dialer

- DTMF / pulse switchable
- Pulse dialling 66/33 or 60/40 or DTMF dialling selectable by pin
- Selectable flashing duration by key pad
- Pause function

Tone Ringer

- 2 Tone ringer
- Adjustable volume
- RC oscillator
- Adjustable threshold

Benefits

- Low number of external components
- High quality through one IC solution

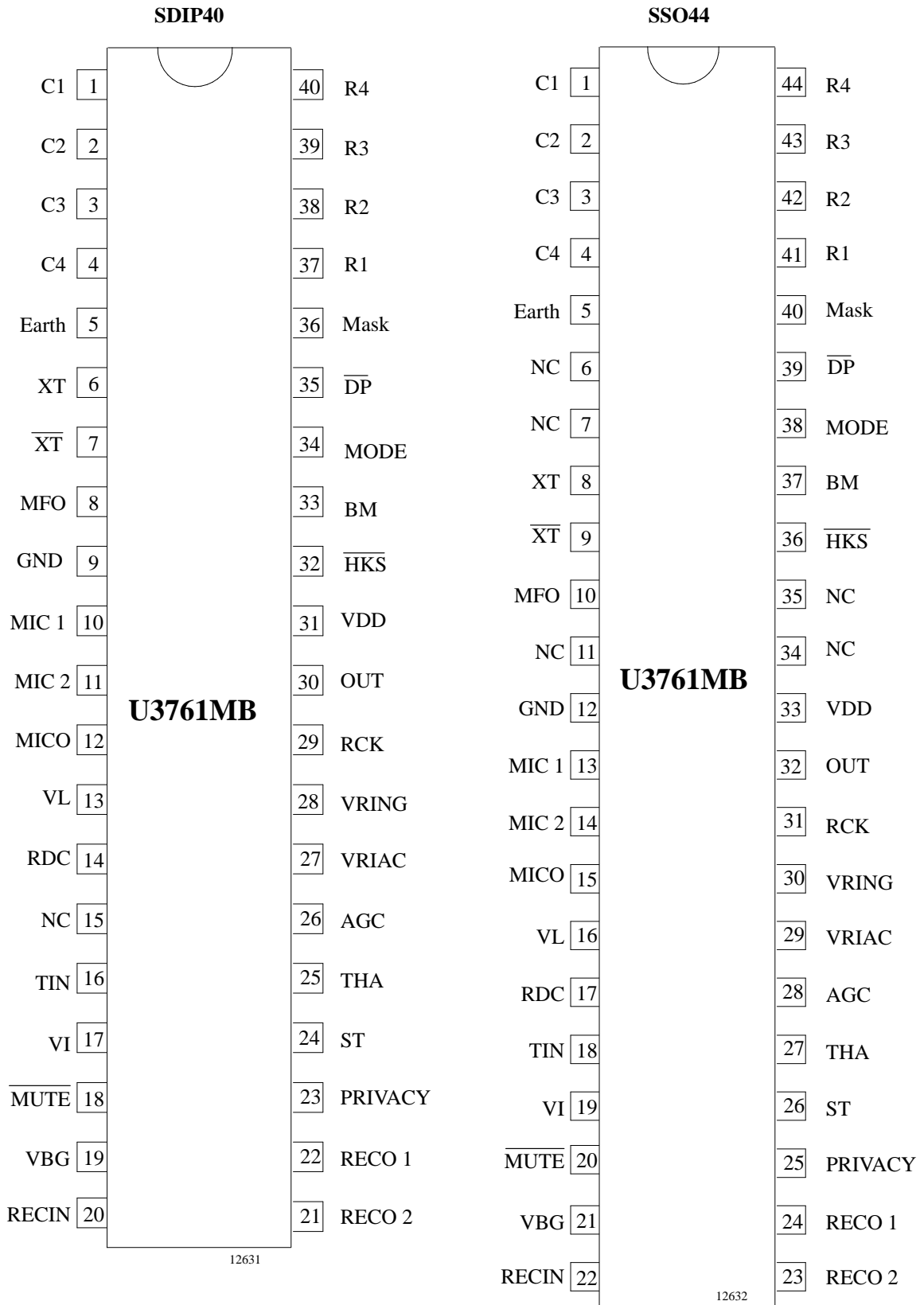

Pin Description

SDIP40	SSO44	Symbol	Configuration	Function																																
1	1	C1		Keyboard input																																
2	2	C2																																		
3	3	C3																																		
4	4	C4																																		
5	5	Earth		Earth key																																
15	7, 6, 34, 35	NC		Not connected																																
6	8	XT		A built-in inverter provides oscillation with an inexpensive 3.579545 MHz crystal or ceramic resonator																																
7	9	$\overline{\text{XT}}$																																		
8	10	MFO		Output of DTMF DTMF output frequency <table border="1"> <thead> <tr> <th></th> <th>Specified (HZ)</th> <th>Actual (Hz)</th> <th>Error (%)</th> </tr> </thead> <tbody> <tr> <td>R1</td> <td>697</td> <td>699</td> <td>+0.28</td> </tr> <tr> <td>R2</td> <td>770</td> <td>766</td> <td>-0.52</td> </tr> <tr> <td>R3</td> <td>852</td> <td>848</td> <td>-0.47</td> </tr> <tr> <td>R4</td> <td>941</td> <td>948</td> <td>+0.74</td> </tr> <tr> <td>C1</td> <td>1209</td> <td>1216</td> <td>+0.57</td> </tr> <tr> <td>C2</td> <td>1336</td> <td>1332</td> <td>-0.30</td> </tr> <tr> <td>C3</td> <td>1477</td> <td>1472</td> <td>-0.34</td> </tr> </tbody> </table>		Specified (HZ)	Actual (Hz)	Error (%)	R1	697	699	+0.28	R2	770	766	-0.52	R3	852	848	-0.47	R4	941	948	+0.74	C1	1209	1216	+0.57	C2	1336	1332	-0.30	C3	1477	1472	-0.34
	Specified (HZ)	Actual (Hz)	Error (%)																																	
R1	697	699	+0.28																																	
R2	770	766	-0.52																																	
R3	852	848	-0.47																																	
R4	941	948	+0.74																																	
C1	1209	1216	+0.57																																	
C2	1336	1332	-0.30																																	
C3	1477	1472	-0.34																																	
9	12	GND		Ground																																

SDIP40	SSO44	Symbol	Configuration	Function
10	13	MIC 1		Inverting input of microphone amplifier
11	14	MIC 2		Non-inverting input of microphone amplifier
12	15	MICO		Transmit pre-amp output which is normally capacitively coupled to Pin TIN
13	16	VL		Positive supply voltage input to the device. The current through this pin is modulated by the transmit signal.

SDIP40	SSO44	Symbol	Configuration	Function
14	17	RDC		An external resistor (1 W) is required from this pin to GND to control the DC input impedance of the circuit. It has a nominal value of 39 Ω for low-voltage operation. Values up to 100 Ω may be used to increase the available transmit output voltage swing at the expense of low-voltage operation.
16	18	TIN		Input to the line output driver amplifier. Transmit AGC applied to this stage.
17	19	V _I		This internal voltage bias line must be connected to VL via an external resistor, R _B , which dominates the AC input impedance of the circuit and should be 680 Ω for an 600 Ω input impedance or 1.2 kΩ for a 900 Ω input impedance.
18	20	MUTE		Pin for testing
19	21	VBG		Pin for test mode
20	22	RECIN		Receive amplifier input. The receiving amplification is regulated by an AGC.
22	24	RECO1		Output of the receive amplifier. Dynamic transducers with a minimum impedance of 100 Ω can be directly driven by these outputs.
21	23	RECO2		

SDIP40	SSO44	Symbol	Configuration	Function
23	25	PRIVACY		Input for handset mute
24	26	ST		The output of the sidetone cancellation signal, which requires a balanced impedance of 8 to 10 times the subscribers line impedance to be connected to Pin VL.
25	27	THA		Ringer threshold adjustment
26	28	AGC		The range of transmit and receive gain variations between short and long loops may be adjusted by connecting a resistor R_{AGC} from this pin to (GND). This pin can be left open to set AGC out of action.
27	29	VRIAC		Ringing supply
28	30	VRING		DC supply voltage for the tone ringer is limited to 30 V with integrated Z-diode.
29	31	RCK		RC clock oscillator for ringer

SDIP40	SSO44	Symbol	Configuration	Function
30	32	OUT		Buzzer output
31	33	VDD		Supply output for dialer part
32	36	$\overline{\text{HKS}}$		Hook switch input. $\overline{\text{HKS}} = 1$: On-hook state. Chip in sleep mode, no operation. $\overline{\text{HKS}} = 0$: Off-hook state. Chip enable for normal operation with a pull-high resistor of about 4 M Ω .
33	37	BM		If BM = floating pulse dialing with 3:2 B/M ratio If BM is connected to ground pulse dialing with a B/M ratio of 2:1
34	38	MODE		Pulling mode pin to V _{DD} places the dialer in tone mode. Pulling mode pin to GND places the dialer in DTMF with 140 ms inter-tone pause. If the mode pin is left floating, the dialer is in pulse mode (10 ppS)
35	39	$\overline{\text{DP}}$		N-channel open drain pulse dialing output. Flash key will cause $\overline{\text{DP}}$ to be active in either DTMF mode or pulse mode.
36	40	Mask		Short mute during pulse dialing

SDIP40	SSO44	Symbol	Configuration	Function
37	41	R1		Keyboard input
38	42	R2		
39	43	R3		
40	44	R4		

Keyboard Operation

	C1	C2	C3	C4	
	1	2	3	S	M1
	4	5	6		M2
	7	8	9	A	M3
	* / T	0	#	R / P	N
VDD ←	F1	F2	F3	E	⏚

- S: Store function key
- A: Indirect repertory dialing function key (LN 0 to 9)
- R/P: Redial and pause function key
- N: Notice function
- * / T: * and pulse-to-tone key
- M1 to M3: One-touch memory
- F1, F2, F3: Flash keys

Normal Dialing

[OFF HOOK] , [D1] , [D2] , ..., [Dn]

1. D1, D2, ..., Dn will be dialed out.
2. Dialing length is unlimited, but redial is inhibited if length oversteps 32 digits.
3. If redialing length oversteps 32 digits, the redialing function will be inhibited.

Redialing

[OFF HOOK] , [D1] , [D2] , ..., [Dn] BUSY, Come [ON HOOK] , [OFF HOOK] , [R/P]

The [R/P] key can execute the redial function only as the first key-in after off-hook; otherwise, it executes the pause function.

Number Store

OFF HOOK , D1 , D2 , ..., Dn , S , S , Mn (or Ln)

1. If the sequence of the dialed digits D1, D2, ..., Dn has not finished S will be ignored.
2. D1, D2, ..., Dn will be stored in memory location and dialed out.

OFF HOOK , S , D1 , D2 , ..., Dn , S , Mn (or Ln)

3. D1, D2, ..., Dn will be stored in memory location but will not be dialed out.
4. R/P and */T keys can be stored as a digit in memory.
In store mode, R/P is the pause function key; */T is the pulse-to-tone function key.
5. The store mode is released after the store function is executed or when the state of the hook switch is changed.

Reportery Dialing

1. OFF HOOK , Mn
2. OFF HOOK , A , Ln

Notice (N)

OFF HOOK , D1 , D2 , ..., Dn , N

1. If the dialing of D1 to Dn is finished, pressing the N key will cause D1 to Dn to be copied to the N memory.

OFF HOOK , N

2. D1 to Dn will be dialed out after the N key is pressed.

Cascaded Dialing

1. Normal dialing + Reportery dialing + Normal dialing
2. Reportery dialing + Normal dialing + Normal dialing
3. Redialing + Normal dialing + Reportery dialing
4. Redialing is valid as first key-in only.

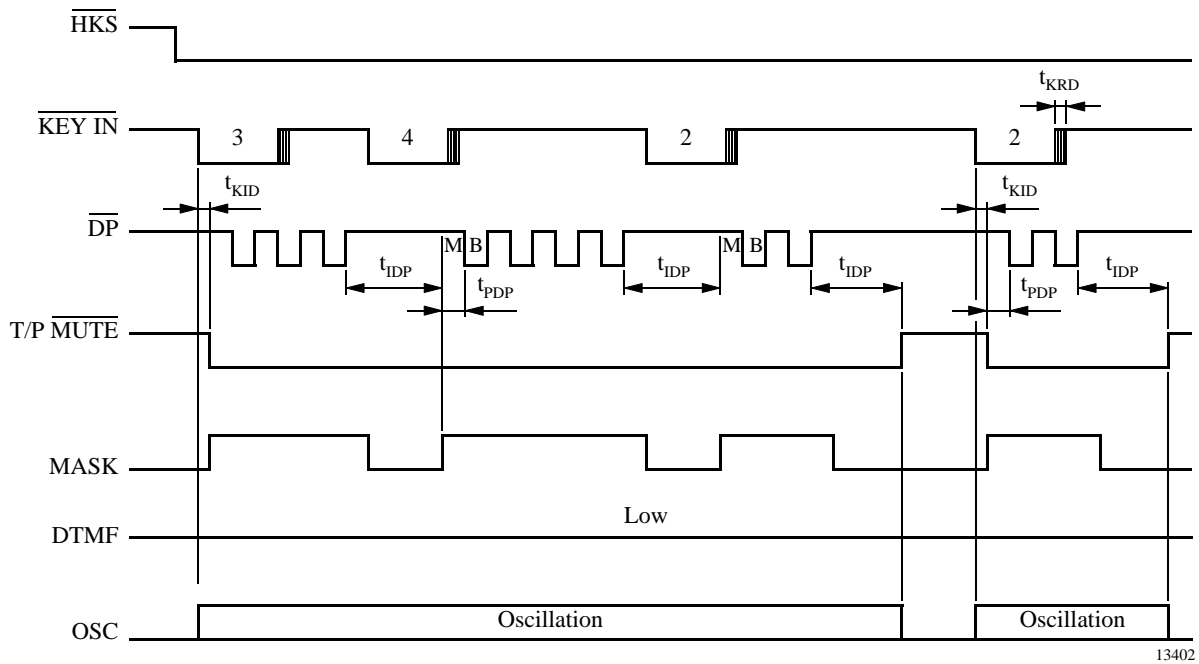

13402

Figure 2. Pulse mode normal dialing

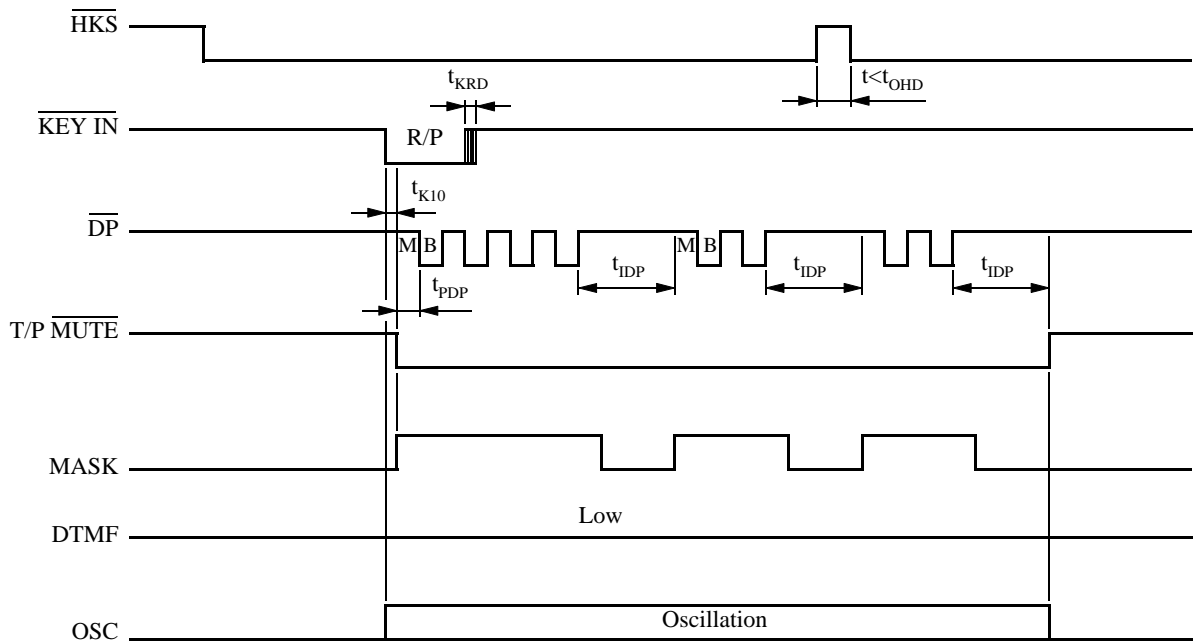

13403

Figure 3. Pulse mode auto dialing

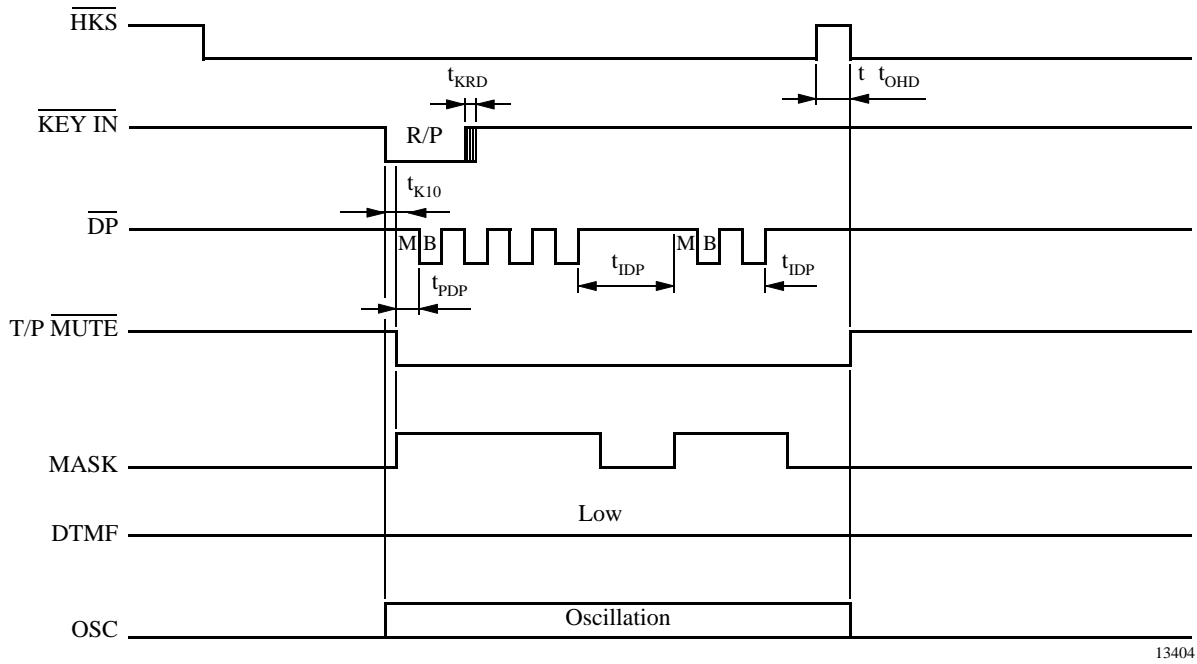

Figure 4. Pulse mode auto dialing

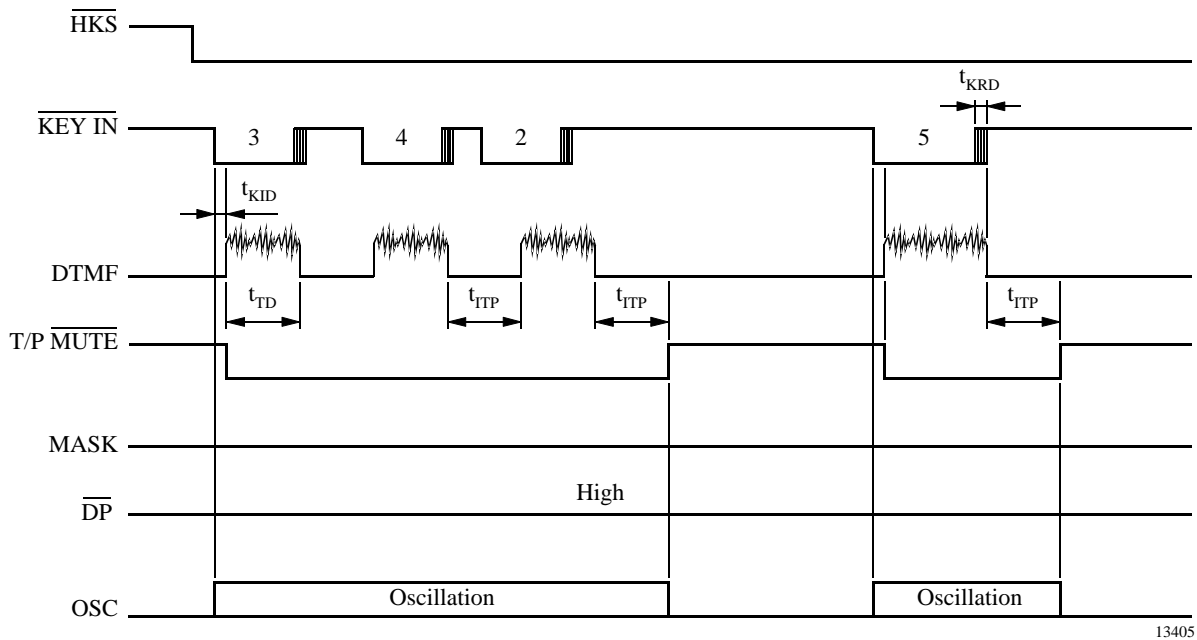
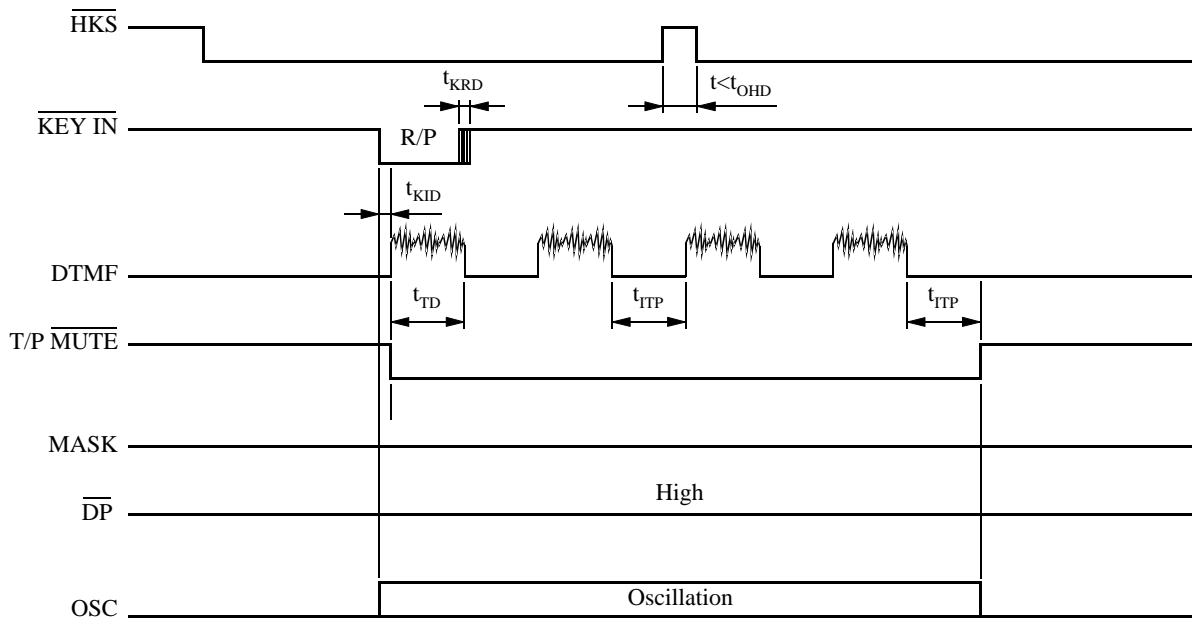
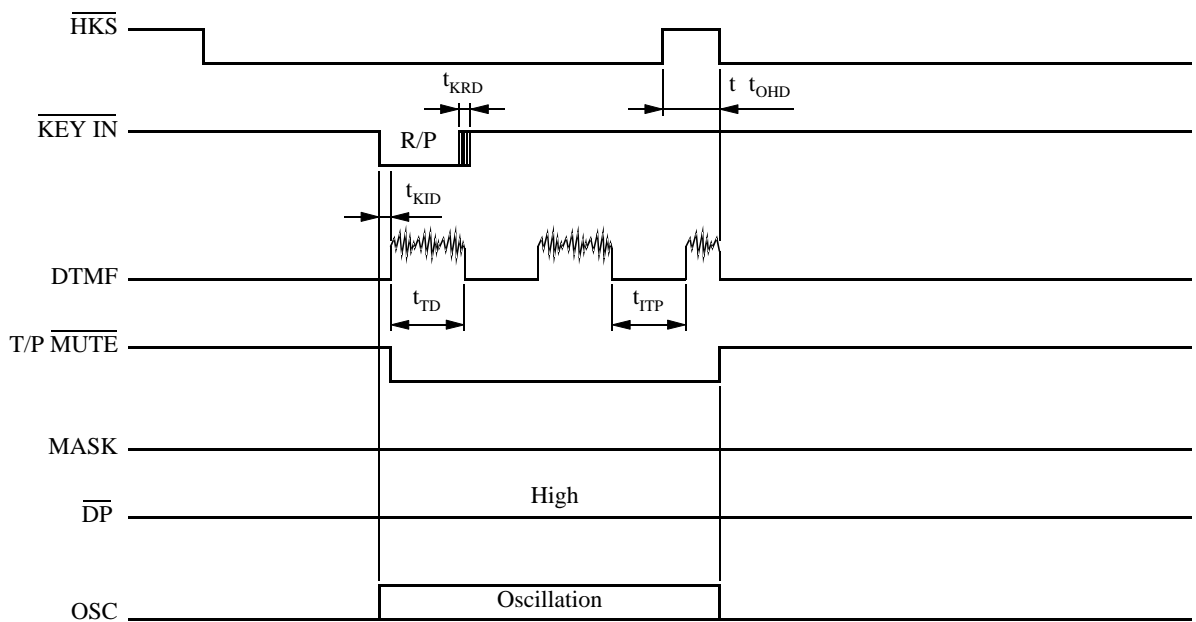

Figure 5. DTMF mode normal dialing



13406

Figure 6. DTMF mode auto dialing



13407

Figure 7. DTMF mode auto dialing

Access Pause

OFF HOOK , D1 , D2 , R/P , D3 , ..., Dn'

1. The pause function can be stored in memory.
2. The pause function is executed in normal dialing and redialing.

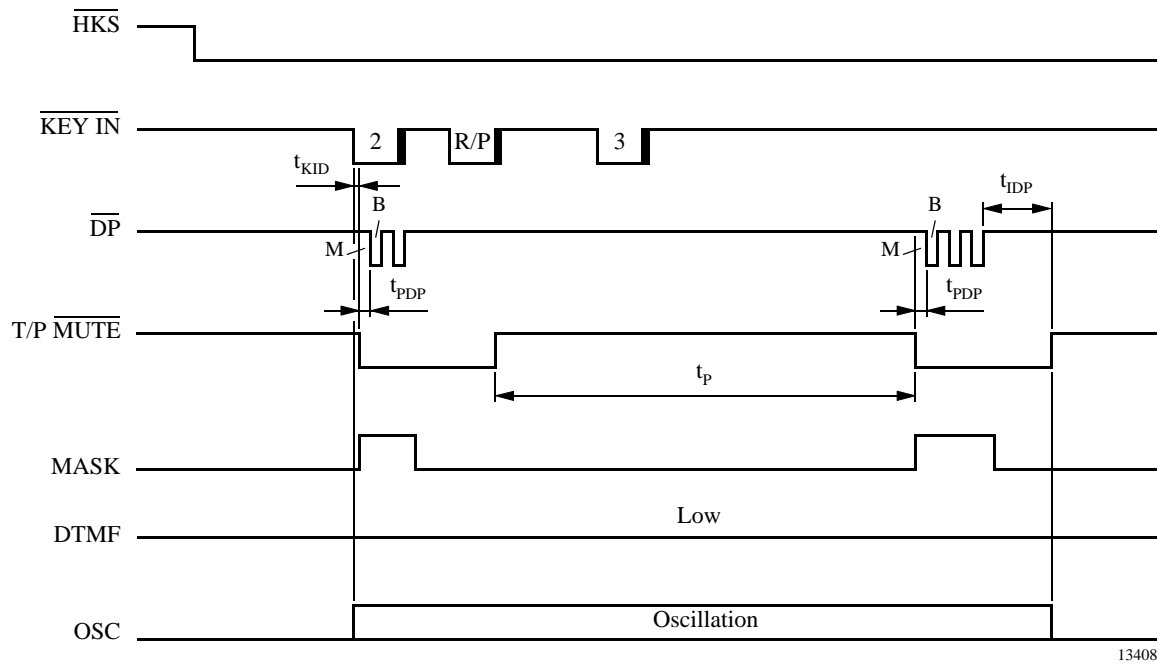

13408

Figure 8. Pause function

Pulse-to-Tone (* / T)

OFF HOOK , D1 , D2 , ..., Dn , * / T , D1' , D2' , ..., Dn'

1. If the mode switch is set to pulse mode, then the output signal will be:
 D1, D2, ..., Dn, Pause (3.6 s), D1', D2', ..., Dn'
 (Pulse) (Tone)
2. If the mode switch is set to tone mode, then the output signal will be:
 D1, D2, ..., Dn, * , D1', D2', ..., Dn'
 (Tone) (Tone) (Tone)
3. The dialer remains in tone mode when the digits have been dialed out and can be reset to pulse mode only by going on-hook.

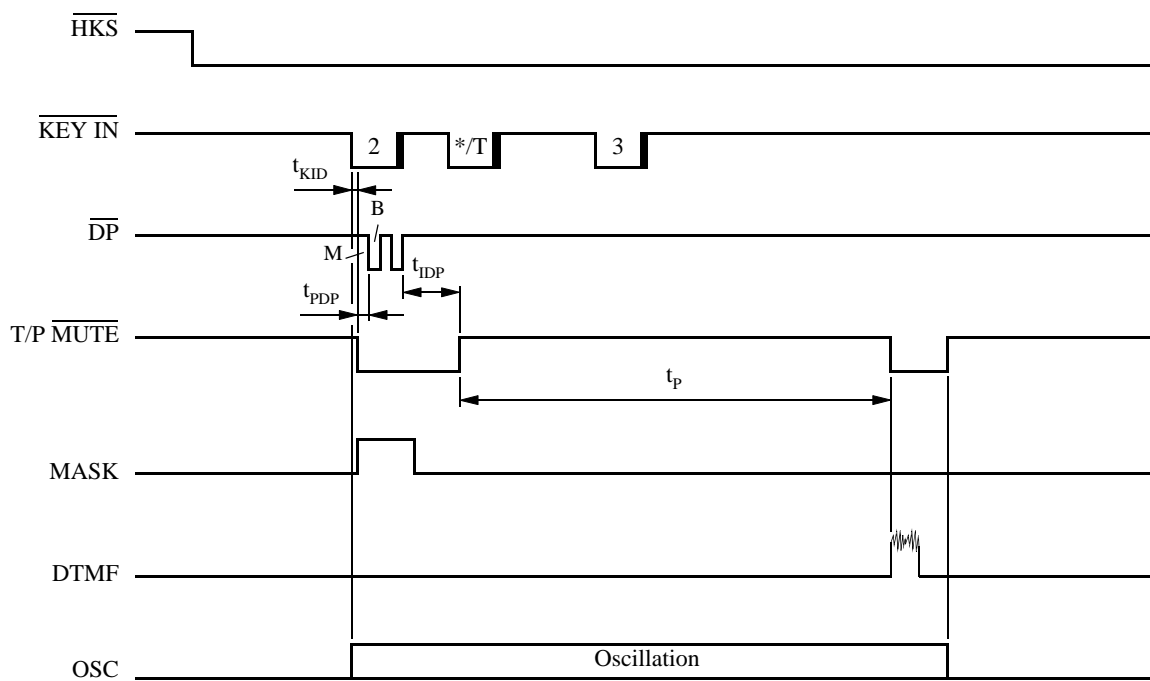

13409

Figure 9. Pulse-to-tone operation

Earth

The Earth pin will go high 400 ms and the pause time of 1 s will be added when the Earth key is pressed. It can be stored as a digit in Memory and has not the first priority.

Flash (F1 or F2 or F3)

OFF HOOK

F_n

1. The dialer will execute flash break and all the flash pause time before the next digits is dialed out.
2. The flash key can be stored as a digit in memory, however, only one flash will be releases to users.
3. The system will return to the initial state after the flash pause time is finished.

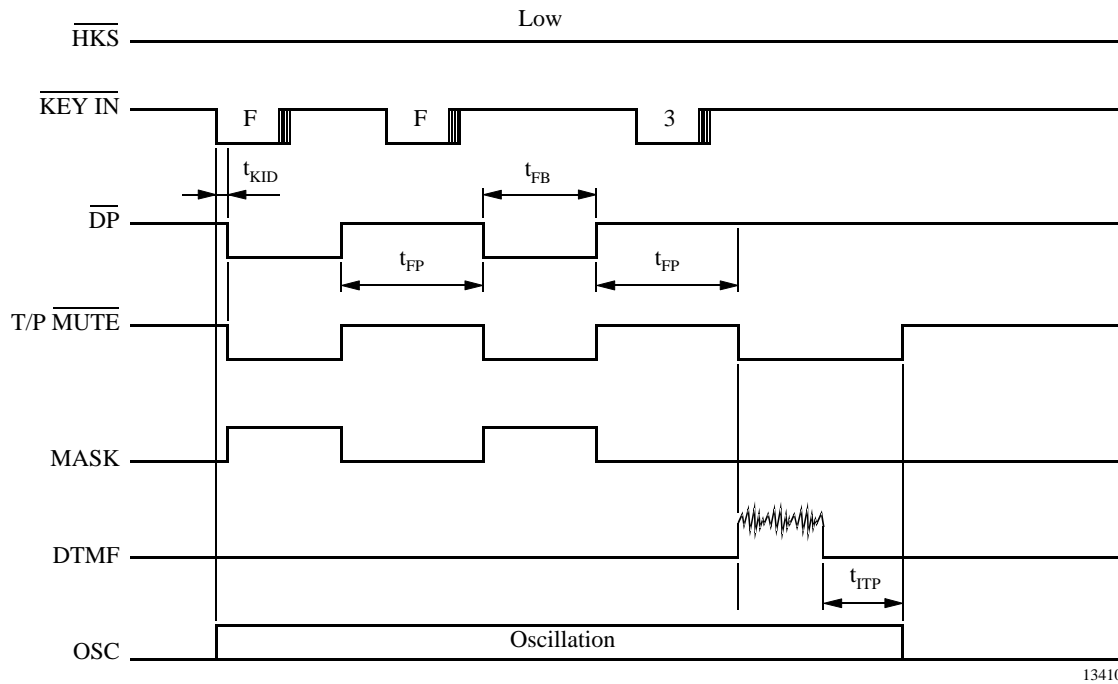

Figure 10. Flash operation

t_{KID} = key active in debounce
 t_{KRD} = key release debounce
 t_{PDP} = pre-digit pause
 t_{IDP} = inter-digit pause
 t_{TD} = DTMF output duration

t_{ITP} = intertone pause
 t_{FB} = flash break time
 t_{FP} = flash pause time
 t_p = pause time

Absolute Maximum Ratings

Parameters	Symbol	Value	Unit	
Line current	I_L	140	mA	
DC line voltage	V_L	14	V	
Junction temperature	T_j	125	°C	
Ambient temperature	T_{amb}	-25 to +75	°C	
Storage temperature	T_{stg}	-55 to +150	°C	
Total power dissipation, $T_{amb} = 60^\circ\text{C}$	SSO44	P_{tot}	0.9	W
	SDIP40	P_{tot}	1.3	W
Junction ambient	SSO44	R_{thJA}	70	K/W
	SDIP40	R_{thJA}	50	K/W

Electrical Characteristics Speech Circuit

Reference point Pin GND, $f = 1000 \text{ Hz}$, $0 \text{ dBm} = 775 \text{ mV}_{\text{rms}}$, $R_{\text{DC}} = 39 \Omega / 1 \text{ W}$, $T_{\text{amb}} = 25^\circ\text{C}$, unless otherwise specified

Parameters	Test Conditions / Pin	Symbol	Min.	Typ.	Max.	Unit
Line voltage	$I_L = 5 \text{ mA}$	V_L	1.2		1.5	V
	$I_L = 20 \text{ mA}$			4.0		V
	$I_L = 30 \text{ mA}$			4.5		V
	$I_L = 73 \text{ mA}$			6.4		V
Transmit and sidetone						
Input resistance	R_i	R_i	45	80	120	k Ω
Gain	$I_L = 20 \text{ mA}$, S5 = open	G_s	46.8	47.8	48.8	dB
Gain change with current	$I_L = 20 \text{ to } 60 \text{ mA}$ $R_{\text{AGC}} = \text{infinite}$	ΔG_s	-0.5		0.5	dB
Gain deviation	$T_{\text{amb}} = -10 \text{ to } +60^\circ\text{C}$ $I_L = 20 \text{ mA}$	ΔG_s	-0.5		0.5	dB
Line-loss compensation	$R_{\text{AGC}} = 12 \text{ k}\Omega$, $I_L = 73 \text{ mA}$	ΔG_s	-4.8	-6	-7	dB
Noise at line weighted psophometrically	$I_L > 20 \text{ mA}$, $G_s = 48\text{dB}$	n_o			-72	dBmp
Sidetone reduction	$I_L \geq 20 \text{ mA}$	G_{STA}	10	15	20	dB
DTMF amplifier						
Volume range $d < 5\%$	Single tone, $I_L \geq 20 \text{ mA}$	V_L	1.3			dBm
DTMF output level low frequency group	$I_L = 20 \text{ mA}$, S5 = closed	V_L	-8		-4	dBm
Pre-emphasis between high and low level frequency group	$P_{\text{PRE}} = P_{\text{HLG}} - P_{\text{LLG}}$, S5 = closed	P_{PRE}	1		3	dB
Receiving amplifier						
Gain	$I_L \geq 20 \text{ mA}$	G_R	3		5	dB
Gain change with current	$I_L = 20 \text{ to } 60 \text{ mA}$ $R_{\text{AGC}} = \text{infinite}$	ΔG_R	-0.5		0.5	dB
Gain deviation	$T_{\text{amb}} = -10 \text{ to } +60^\circ\text{C}$ $I_L = 20 \text{ mA}$	ΔG_R	-0.3		0.7	dB
Line-loss compensation	$I_L = 73 \text{ mA}$	ΔG_R	-4.7	-6	-7	dB
Receiving noise at earphone weighted psophometrically	$I_L = 73 \text{ mA}$	n_i		-77.5	-71	dBm
Gain change when muted	$I_L \geq 20 \text{ mA}$	G_{RM}	24	29	34	dB
Output voltage push-pull	$I_L \geq 20 \text{ mA}$, $Z_{\text{ear}} = 68 \text{ nF}$, 100 Ω in series	V_{RECO}	0.8	0.9		V_{RMS}
Ear protection differential	$I_L = 40 \text{ mA}$, $V_{\text{gen}} = 4 \text{ V}_{\text{rms}}$, $Z_{\text{ear}} = 68 \text{ nF} + 100 \Omega$	V_{ear}	1.3	1.6	2.5	V_{rms}
Supply voltage (for internal use only)						
Output voltage	$I_L \geq 20 \text{ mA}$ dialing mode	V_{DD}	2.3		6.3	V
Distortion at line $V_L = 0.775 \text{ V}_{\text{rms}}$	$I_L = 20 \text{ mA}$, S5 = open	d_t			2	%
Maximum output voltage swing at line	$I_L = 20 \text{ mA}$, $V_{\text{mic}} = 50 \text{ mV}_{\text{off}}$	$V_{L \text{ max}}$		3.4	4	V_{pp}
Mute suppression transmit with privacy function	$I_L = 20 \text{ mA}$	G_{SPRIV}	60			dB

DC Characteristics Dialer

$V_{DD2} = 2.7\text{ V}$, $f_{OSC} = 3.58\text{ MHz}$, all outputs unloaded, S9b

Parameters	Test Conditions / Pins	Symbol	Min.	Typ.	Max.	Unit
Memory retention current	$\overline{HKS} = 1$, $V_{DD2} = 1.0\text{ V}$	I_{MR}			0.2	μA
Pre-emphases	Column/Row		1	2	3	dB
DTMF distortion	$R_L = 5\text{ k}\Omega$	d		-30	-23	dB
DP output sink current	$V_{PO} = 0.5\text{ V}$	I_{PL}	0.5			mA
Keyboard input drive current	$V_I = 0\text{ V}$	I_{KD}	30			μA
Keyboard input sink current	$V_I = 2.7\text{ V}$	I_{KS}	200	400		μA
Keyboard resistance					5	$\text{k}\Omega$
F1, F2, F3, E board resistance					300	Ω
Mask sink / drive current		$I_M\text{ H/L}$	0.5			mA
Earth sink / drive current		$I_e\text{ H/L}$	0.5			mA

AC Characteristics Dialer

Parameters	Test Conditions / Pins	Symbol	Min.	Typ.	Max.	Unit
Keypad active in de-bounce		t_{KID}		20		ms
Key release debounce		t_{KRD}		20		ms
Pre-digit pause	B/M pin = floating	t_{PDP}		40		ms
	B/M pin = low	t_{PDP}		33.3		ms
Inter-digit pause (auto dialing)	10 ppS	t_{IDP}		800		ms
Make/break ratio	B/M pin = floating	M/B		40:60		%
	B/M pin = low			33:67		%
DTMF output duration	Auto dialing, $\text{MODE} = V_{DD}$ $\text{MODE} = \text{GND}$	t_{TD}		87 70		ms
Inter-tone pause	Auto dialing, $\text{MODE} = V_{DD}$ $\text{MODE} = \text{GND}$	t_{ITP}		87 140		ms
Flash break time F1 F2 F3	C_1 connected to V_{DD} C_2 connected to V_{DD} C_3 connected to V_{DD}	t_{FB}		98		ms
				250		ms
				600		ms
Flash pause time	F1 F2 F3	t_{FP}		1		s
Pause time		t_p		3.6		s
On Hook debounce time		t_{ohd}		150		ms
Earth time	C_4 connected to V_{DD}	t_{et}		400		ms
Earth pause time		t_{pt}		1		s

Electrical Characteristics Tone Ringer

$f_{RCK} = 4 \text{ kHz}$, $V_{RING} = 20 \text{ V}$, $T_{amb} = 25^\circ\text{C}$, reference point GND, unless otherwise specified

Parameters	Test Conditions / Pins	Symbol	Min.	Typ.	Max.	Unit
Supply current, outputs open	$V_{RIAC} = 20 \text{ V}$	I_{RING}	2.1		3.8	mA
Switch-on threshold	V_{RIAC}	V_{RON}		23.5		V
Switch-off threshold	V_{RIAC}	V_{ROFF}		5.6		V
Ringing frequency	$R = 150 \text{ k}\Omega$, $C = 1 \text{ nF}$ $V_{RIAC} > V_{RON}$	f_{IH}	937	1010	1083	Hz
		f_{IL}	752	808	868	
Audio sequence frequency		f_2	11.5	12.5	14.0	Hz
Output voltage swing	$V_{Ring} = 25 \text{ V}$, $C_{out} = 68 \text{ nF}$	V_{out}	21	23		V_{pp}
Turn-off delay	See figure 11	t_{off}		65		ms

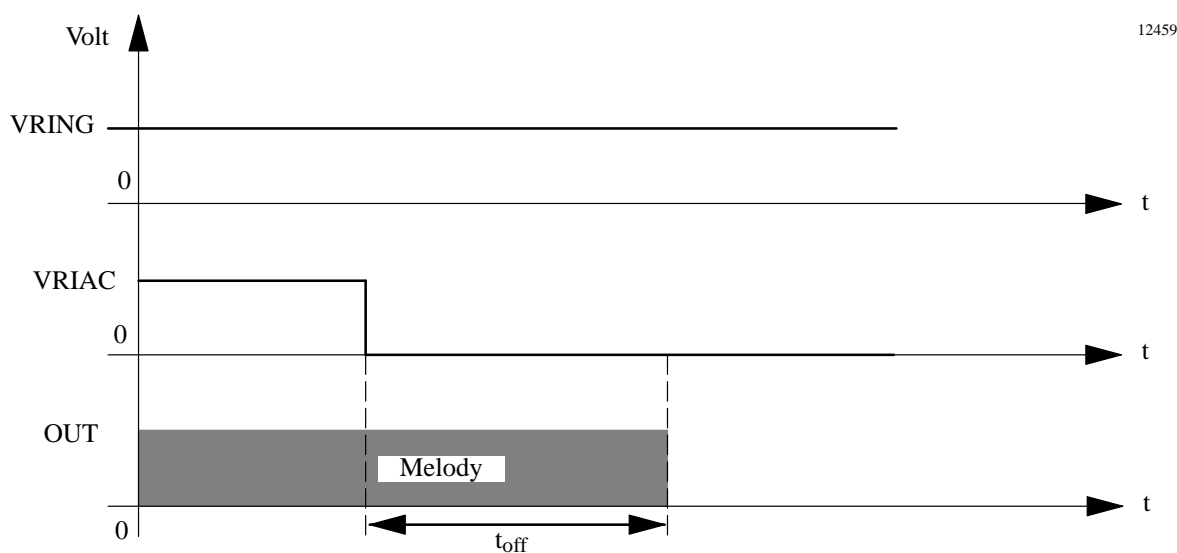
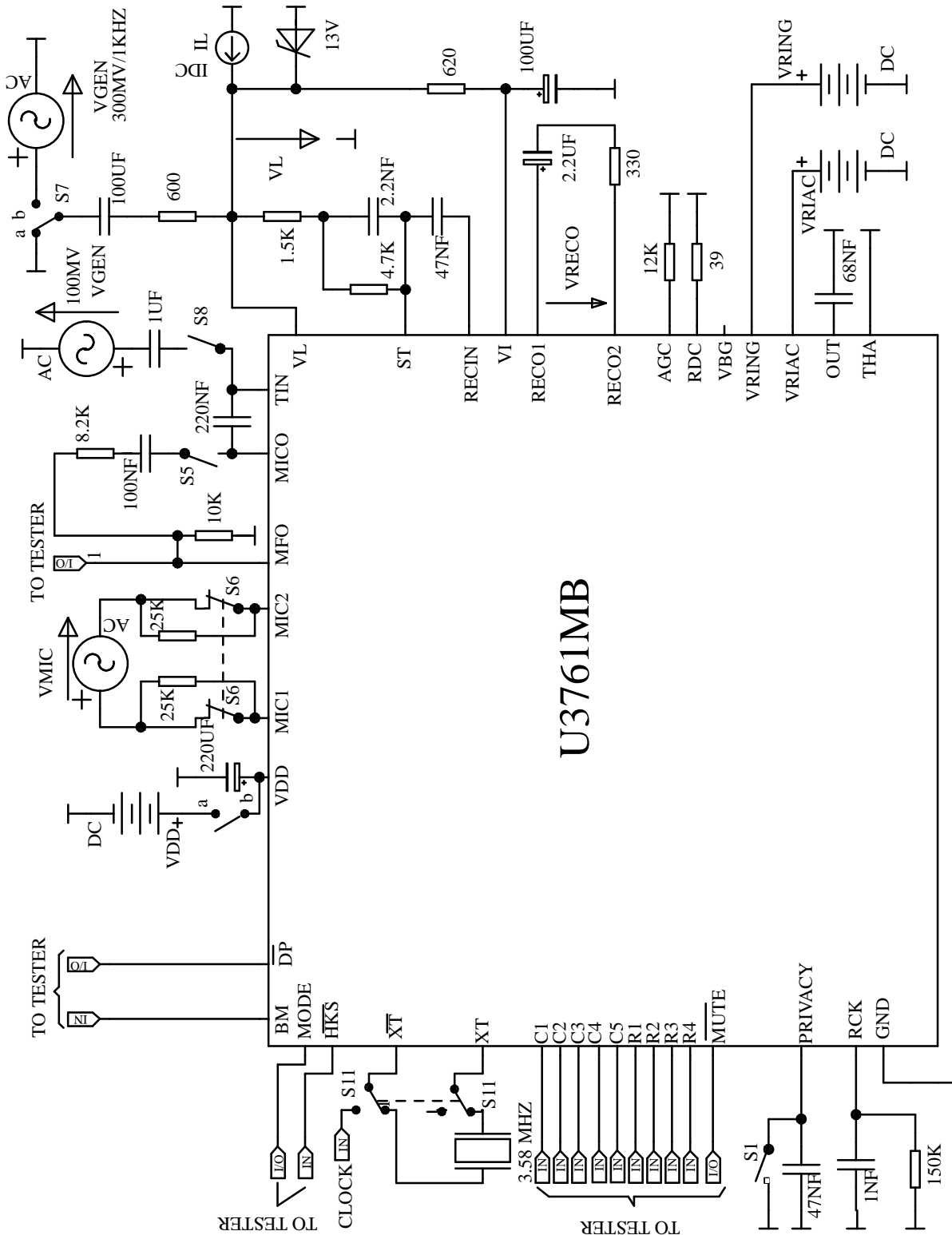

Figure 11. Turn off delay time

Ordering Information

Type	Package
U3761MB-ASD	SDIP40
U3761MB-AFN	SSO44
U3761MB-AFNG3	SSO44 tape and reel

Basic Test Circuit



12633

Formulas for Parameters of Electrical Characteristics of Speech Circuit

Formulas referred to the basic test circuit. If not otherwise specified switches in basic test circuit are inactive.

Transmit gain

$$GS = 20 \times \log \left(\frac{VL}{VMIC} \right)$$

VMIC = 3 mV/1 kHz, S5 = open

Receiving gain

$$GR = 20 \times \log \left(\frac{VRECO}{VL} \right)$$

RX-mode: VGEN = 300 mV/1 kHz, S7b

Line loss compensation transmit

$$\Delta GS = GS(\text{at IL} = 73 \text{ mA}) - GS(\text{at IL} = 20 \text{ mA})$$

TX-mode: VMIC = 3 mV/1 kHz, S5 = open

Sidetone reduction

$$GSTA = 20 \times \log \left(\frac{VL}{VRECO} \right) (\text{in TX-mode}) + GR$$

TX-mode: VMIC = 3 mV/1 kHz, S5 = open

Line loss compensation receive

$$\Delta GR = GR(\text{at IL} = 73 \text{ mA}) - GR(\text{at IL} = 20 \text{ mA})$$

RX-mode: VGEN = 300 mV/1 kHz, S7b

Gain change when muted

$$GRM = 20 \times \log \frac{VRECO}{VL} (\text{Mute} = \text{inactive}) - 20 \times \log \frac{VRECO}{VL} (\text{Mute} = \text{active})$$

VGEN = 100 mV/1 kHz, S5 = open, S8 = open

Input impedance of microphone amplifier

$$Ri = \frac{50 \text{ k}}{\left(\frac{VL_{(S6 = \text{closed})}}{VL_{(S6 = \text{open})}} - 1 \right)}$$

TX-mode: VMIC = 3 mV/1 kHz, S5 = open

Packaging Information

Package SDIP40

Dimensions in mm

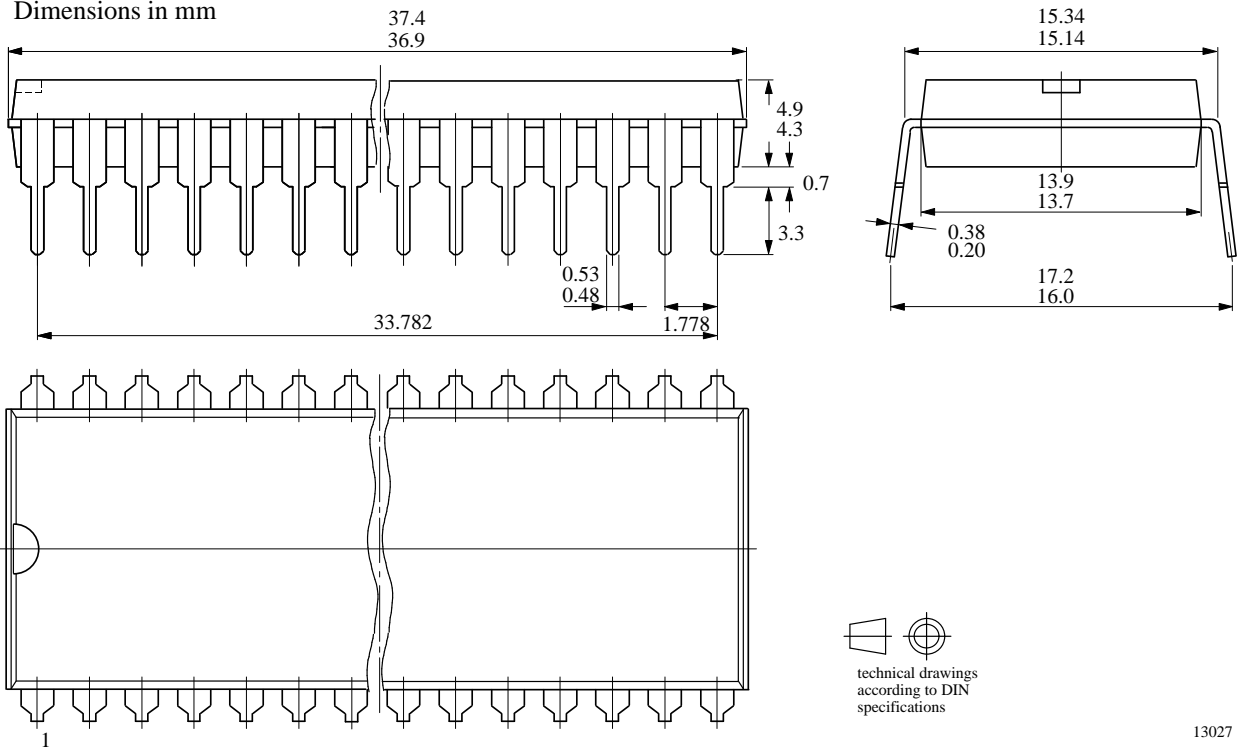

Package SSO44

Dimensions in mm

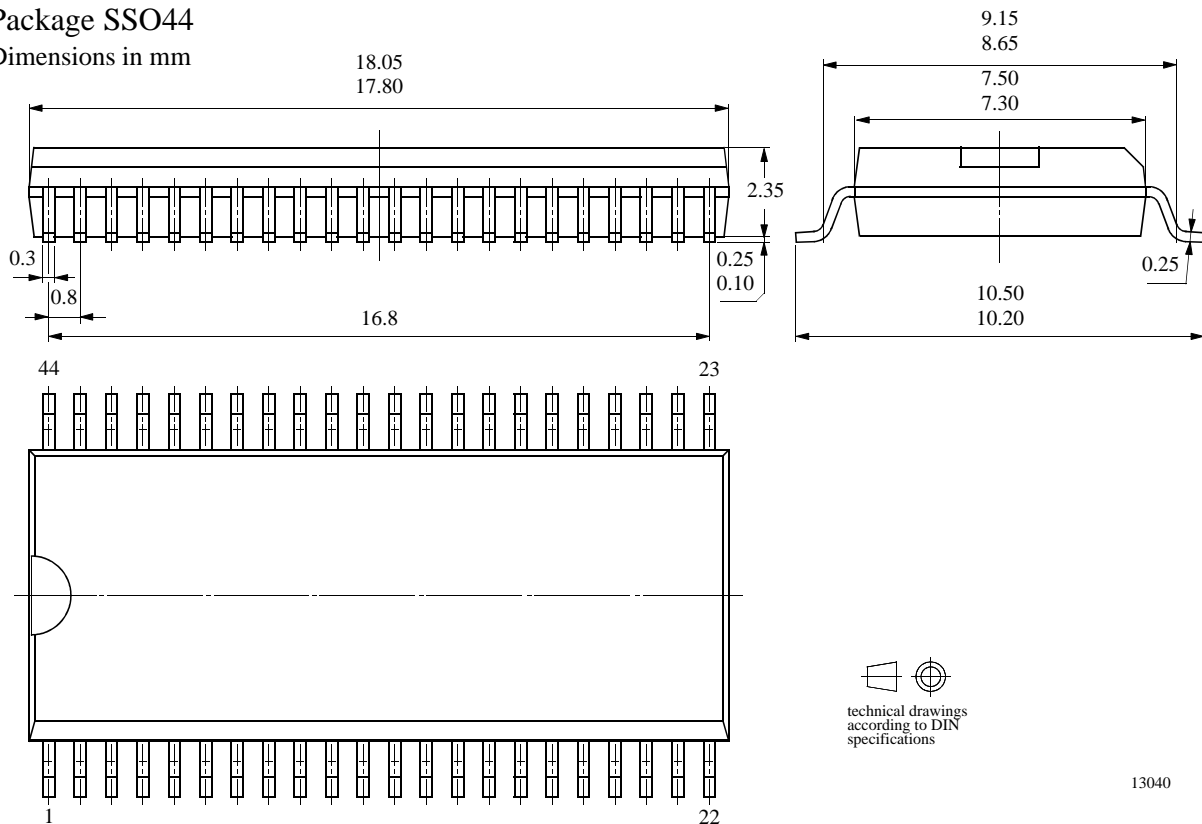

Ozone Depleting Substances Policy Statement

It is the policy of **TEMIC TELEFUNKEN microelectronic GmbH** to

1. Meet all present and future national and international statutory requirements.
2. Regularly and continuously improve the performance of our products, processes, distribution and operating systems with respect to their impact on the health and safety of our employees and the public, as well as their impact on the environment.

It is particular concern to control or eliminate releases of those substances into the atmosphere which are known as ozone depleting substances (ODSs).

The Montreal Protocol (1987) and its London Amendments (1990) intend to severely restrict the use of ODSs and forbid their use within the next ten years. Various national and international initiatives are pressing for an earlier ban on these substances.

TEMIC TELEFUNKEN microelectronic GmbH semiconductor division has been able to use its policy of continuous improvements to eliminate the use of ODSs listed in the following documents.

1. Annex A, B and list of transitional substances of the Montreal Protocol and the London Amendments respectively
2. Class I and II ozone depleting substances in the Clean Air Act Amendments of 1990 by the Environmental Protection Agency (EPA) in the USA
3. Council Decision 88/540/EEC and 91/690/EEC Annex A, B and C (transitional substances) respectively.

TEMIC can certify that our semiconductors are not manufactured with ozone depleting substances and do not contain such substances.

We reserve the right to make changes to improve technical design and may do so without further notice.

Parameters can vary in different applications. All operating parameters must be validated for each customer application by the customer. Should the buyer use TEMIC products for any unintended or unauthorized application, the buyer shall indemnify TEMIC against all claims, costs, damages, and expenses, arising out of, directly or indirectly, any claim of personal damage, injury or death associated with such unintended or unauthorized use.

TEMIC TELEFUNKEN microelectronic GmbH, P.O.B. 3535, D-74025 Heilbronn, Germany
Telephone: 49 (0)7131 67 2831, Fax number: 49 (0)7131 67 2423