

CT2 I/Q Modulator and Clock Circuitry

Description

The U3770M is a quadrature modulator realized using Atmel Wireless & Microcontrollers' advanced 0.8 micron CMOS process. The IC is especially designed for CT2 applications in conjunction with Atmel Wireless & Microcontrollers' RF/IF signal processor U2760B and a CT2 baseband controller (i.e., AMD PhoX™ controller

Am79C4xx). Together with Atmel Wireless & Microcontrollers' PLL IC U2783B and the GaAs front end U7001BG, a complete CT2 chip set is available.

Electrostatic sensitive device.

Observe precautions for handling.



Features

- Programmable 0.8/1.6-MHz quadrature-modulated carrier generation
- More than 26 dB LO and sideband suppression
- 18.432 MHz CMOS level clock generation
- Supply-voltage range 2.7 V to 3.3 V
- Low power consumption, typically 12 mW
- SO16 package or die form

Block Diagram

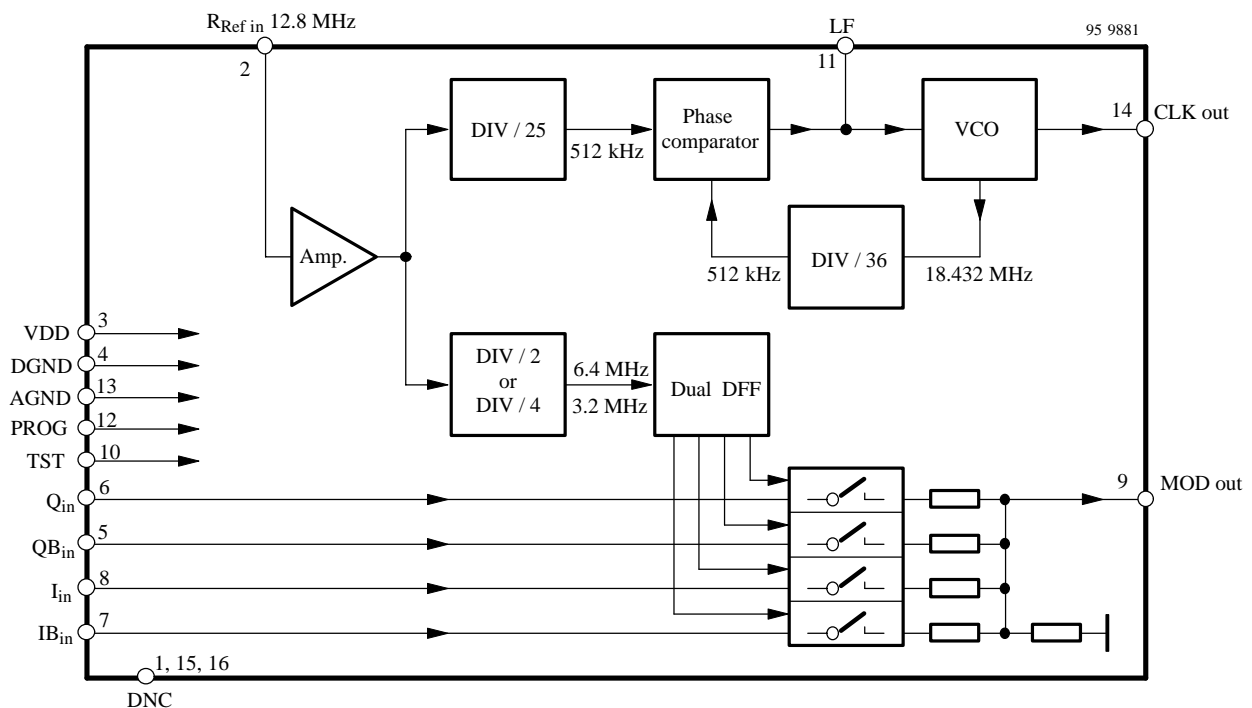

Figure 1. Block diagram

Ordering Information

Extended Type Number	Package	Remarks
U3770M-MFP	SO16	Tube
U3770M-MFPG3	SO16	Taped and reeled

Functional Description

The U3770M has been designed to reduce power consumption and cost of CT2 devices. An innovative CMOS I/Q modulator with extremely low current provides all the advantages of I/Q modulation:

- No requirement for FM deviation tuning
- Eliminates the Gaussian filter
- Simplifies the power ramping control

The modulated output carrier can be programmed to be 0.8 MHz or 1.6 MHz by the PROG control pin.

The typical supply voltage is 3 V @ 4 mA.

To reduce overall system cost, an internal PLL generates an 18.432-MHz clock signal from the system's 12.8-MHz

reference oscillator. This way, only one crystal oscillator is needed in the complete CT2 device.

Internally, the 12.8-MHz reference signal is fed into a shaping amplifier and then into two logic dividers, to generate a 512-kHz and a programmable 3.2-MHz or 6.4-MHz clock. This clock is divided by 4 by two D flip-flops. The flip-flop outputs drive the four analog switches in quadrature. The local oscillator (LO) suppression mixer consists of a pair of analog switches. make a local oscillator (LO) suppression mixer. By summing the other pair outputs the suppression (both LO and side tone) is <-26 dBc.

The 512-kHz clock drives a frequency synthesizer. The VCO runs at a fixed frequency of 18.432 MHz. The VCO control voltage (LF pin) controls the VCO frequency.

Pin Description

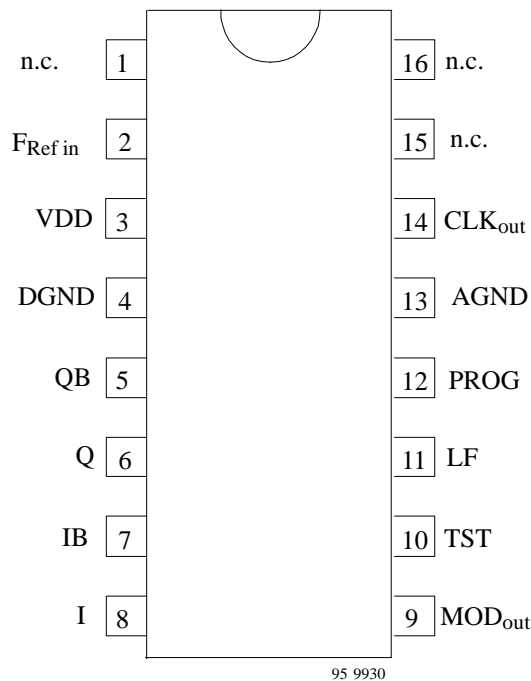

Figure 2. Pinning

Pin	Symbol	Function
2	F _{Ref in}	External 12.8-MHz reference frequency input
3	VDD	Supply voltage
4	DGND	Digital ground
5	QB _{in}	Analog switch input
6	Q _{in}	Analog switch input
7	IB _{in}	Analog switch input
8	I _{in}	Analog switch input
9	MOD _{out}	Modulator output signal
10	TST	Test input, must be connected to GND (only factory use)
11	LF	PLL loop filter
12	PROG	PROG = 0, 1.6-MHz mode PROG = 1, 0.8-MHz mode
13	AGND	Analog ground
14	CLK _{out}	Digital CMOS clock output 18.432 MHz
1, 15, 16	n.c.	Not connected

Absolute Maximum Ratings

Stresses at or above those listed may cause permanent damage to the device. This is a stress rating only and functional operation of the device at these or any other conditions above those indicated in this data sheet is not implied. Exposure to absolute maximum rating conditions for extended periods may affect device reliability.

Parameters	Symbol	Value	Unit
Supply voltage	V_{DD}	6	V
Modulator input voltages	I, IB, Q, QB	-0.5 to V_{DD}	V
Reference frequency input	$F_{Ref\ in}$	-0.5 to V_{DD}	V
Ambient temperature	T_{amb}	-40 to +85	°C
Storage temperature	T_{stg}	-65 to +150	°C
Junction temperature	T_j	$T_j < T_{amb} + 10$	°C

Operating Range

Parameters	Symbol	Value	Unit
Supply voltage	V_{DD}	$3 \pm 10\%$	V
Ambient temperature	T_{amb}	-5 to +70	°C
Junction temperature	T_j	$T_j < T_{amb} + 5$	°C
Storage temperature	T_{stg}	-40 to +125	°C

Electrical Characteristics

Test conditions (unless otherwise specified) related to test circuit

$V_S = 3\text{ V}$, V_{BII} , V_{BI} and V_{BQi} , $V_{BQi} = 1\text{ V}_{PP}$ single ended, oscillator frequency $F_{Ref\ in} = 12.8\text{ MHz}$, $T_{amb} = -5\text{ to }+70^\circ\text{C}$

Parameters	Test Conditions / Pins	Symbol	Min.	Typ.	Max.	Unit
Supply-voltage range	Pin 3	V_{DD}	2.7	3	3.3	V
Supply current	Pin 3	I_{DD}		4		mA
$F_{Ref\ in}$	Pin 2					
Input voltage		$V_{F\ Ref\ in}$	150			mV _{PP}
Input impedance		$Z_{F\ Ref\ in}$	100			k Ω
I, Q inputs	Pins 5, 6, 7 and 8					
Input voltage	Single ended	$V_{Iin, Qin}$		1		V_{PP}
Input impedance	Single ended	$Z_{Iin, Qin}$		20		k Ω
Input frequency		$F_{Iin, Qin}$		18		kHz
External bias voltage		$V_{IB, QB}$		1.5		V
MOD_{out}	Pin 9					
Output level ¹⁾	Unloaded	$V_{Mod\ out}$		70		mV _{RMS}
LO and sideband suppression		LO sub SB sub		-26		dBc
Output impedance		$Z_{Mod\ out}$		5		k Ω
CLK_{out}	Pin 14					
Output frequency		$F_{CLK\ out}$		18.432		MHz
Output-voltage swing	@ load = 20 pF	$V_{CLK\ out}$	1.8			V

U3770M



Note ¹⁾ The output signal contains some harmonics to be filtered by an external lowpass filter

Test Circuit

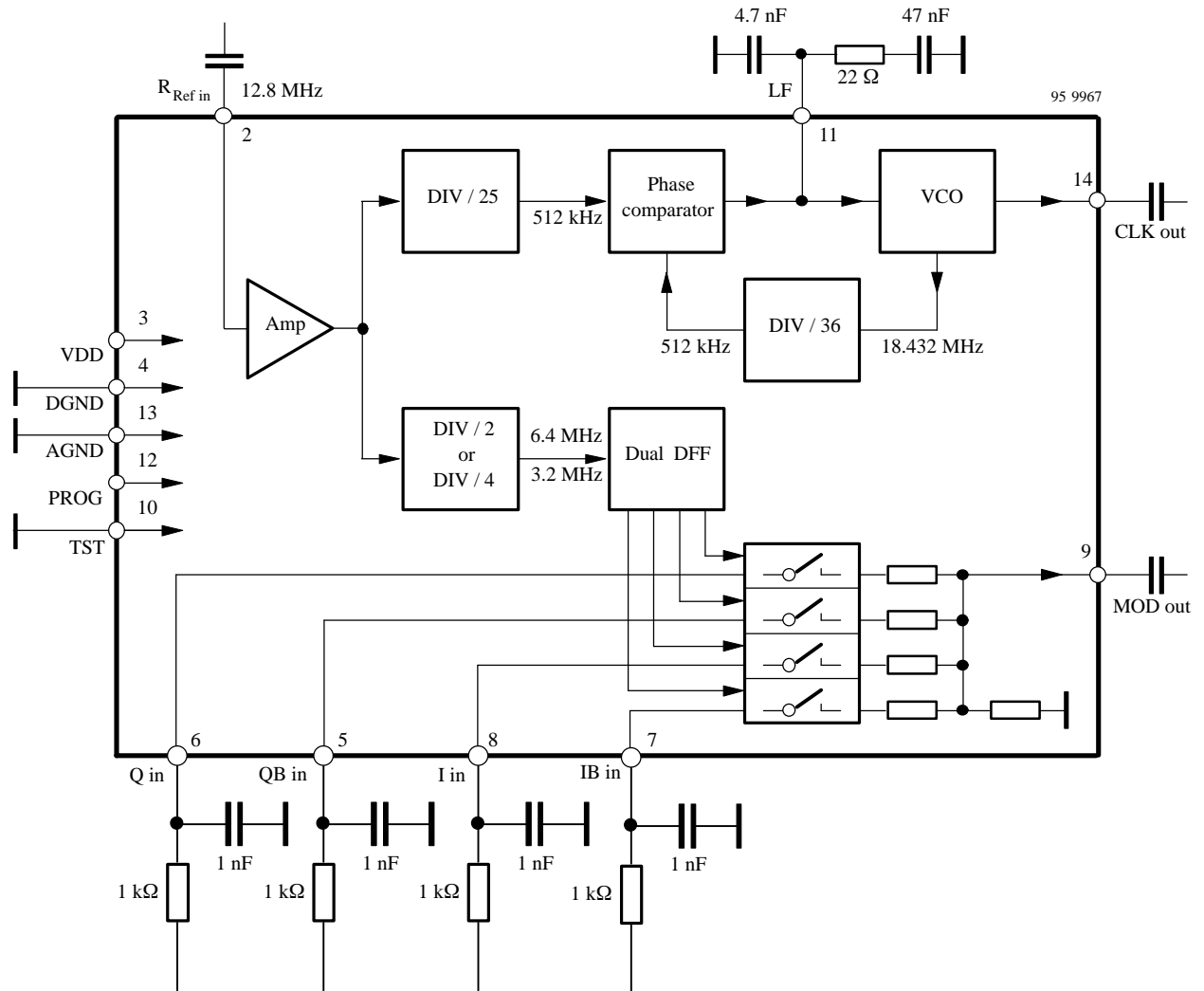
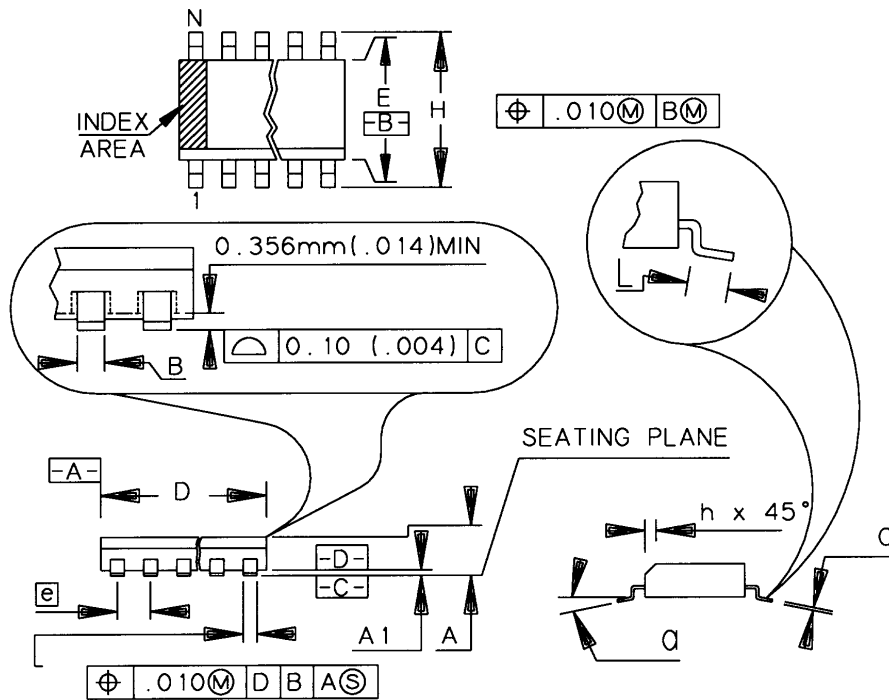

Figure 3. Test circuit

Package Information

Package: SO16

16 PINS SO .150



	MM		INCH	
A	1.55	1.73	.061	.068
A1	0.127	0.25	.004	.0098
B	0.35	0.49	.014	.019
C	0.19	0.25	.0075	.0098
D	9.80	9.98	.386	.393
E	3.81	3.99	.150	.157
e	1.27	BSC	.050	BSC
H	5.84	6.20	.230	.244
h	0.25	0.41	.010	.016
L	0.41	0.89	.016	.035
N	16		16	
a	0°		8°	

We reserve the right to make changes to improve technical design and may do so without further notice.

Parameters can vary in different applications. All operating parameters must be validated for each customer application by the customer. Should the buyer use TEMIC Semiconductors products for any unintended or unauthorized application, the buyer shall indemnify TEMIC Semiconductors against all claims, costs, damages, and expenses, arising out of, directly or indirectly, any claim of personal damage, injury or death associated with such unintended or unauthorized use.

Data sheets can also be retrieved from the Internet: <http://www.temic-semi.com>

TEMIC Semiconductor GmbH, P.O.B. 3535, D-74025 Heilbronn, Germany
 Telephone: 49 (0)7131 67 2594, Fax number: 49 (0)7131 67 2423