

Quasi-Split Sound Circuit and AM Demodulator

Description

The U4488B is an integrated bipolar circuit for full multi-standard sound IF signal processing in TV/VTR and Multimedia applications. It supplies AM signals as well as FM/NICAM sound IF signals and thus allows the de-

sign of a universal sound IF module for various applications. The U4488B has the same performance like the U4468B, with the additional feature of a second symmetrical IF input.

Features

- 5-V supply voltage; low power consumption
- Gain-controlled 3-stage wideband IF amplifier
- Active carrier generation by FPLL principle (frequency-phase-locked-loop) for true quadrature demodulation
- Complete alignment-free AM demodulator
- Switchable amplitude detector for gain control, which operates as a peak detector for FM sound and as a mean level detector for AM sound
- Two symmetrical IF inputs

Block Diagram

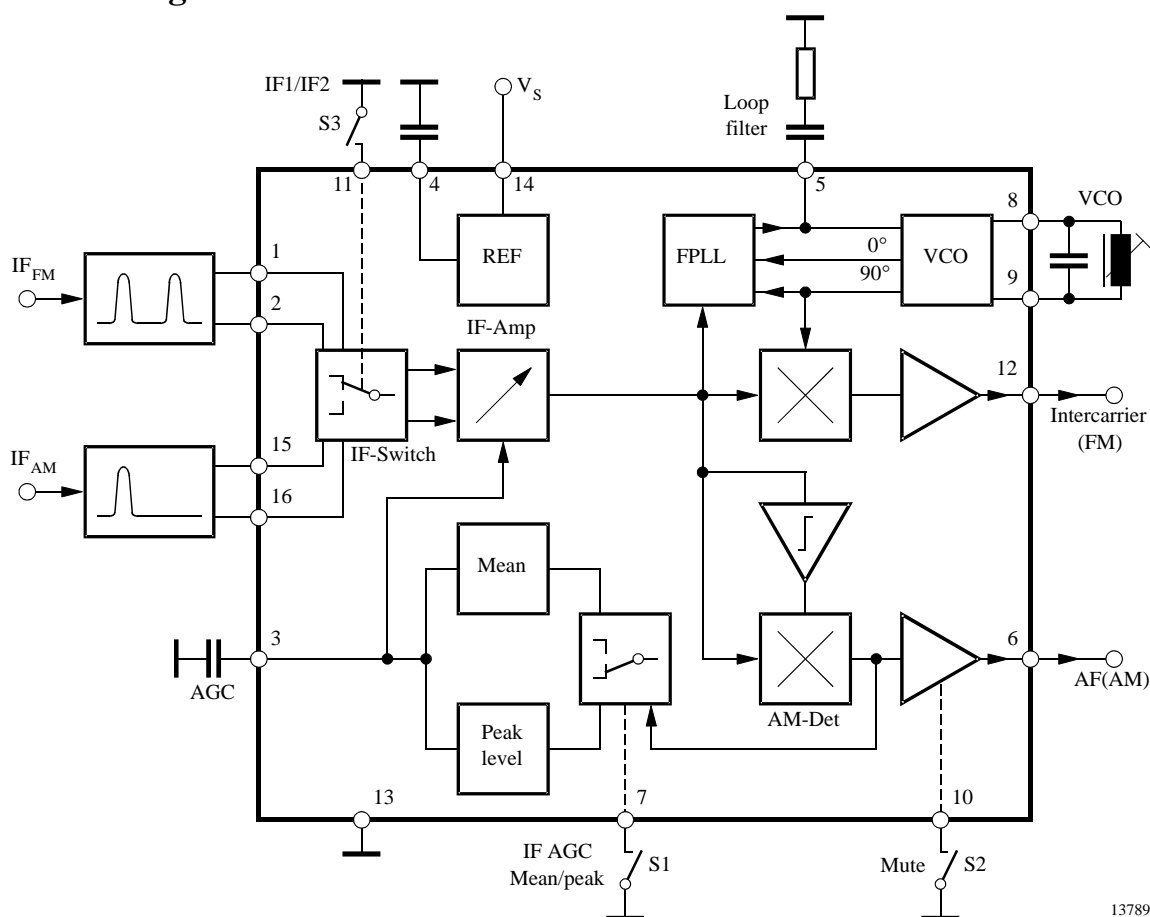

Figure 1. Block diagram

Ordering Information

Extended Type Number	Package	Remarks
U4488B	DIP16	

Circuit Description

IF Amplifier and AGC

The symmetrical IF input signal from the external SAW filter is fed to the Pins 1 and 2 resp. Pins 15 and 16. For FM/NICAM application, a SAW filter with double bandpass characteristic is required for the vision and sound carrier. In case of L-standard, a bandpass filter with the center frequency at the L-sound carrier is used.

The amplifier consists of three AC-coupled wideband IF stages. Each differential amplifier stage is gain controlled by the AGC (Automatic Gain Control) voltage, available at Pin 3. The output signal of the IF amplifier is then applied to the FPLL carrier generation, to the mixer for FM/NICAM signals and to the AM demodulator.

The IF-AGC is derived from the average level of the AM carrier (L standard) or from the peak value of the FM carrier (e.g., B/G standard). It controls the three-stage wideband amplifier to provide a constant SIF signal to the AM demodulator or to the QSS (quasi-split sound) mixer.

IF Input Switch

If Pin 11 is open, the IF input 1 is switched on (Pins 1 and 2). If Pin 11 is connected to ground, the IF input 2 is switched on (Pins 15 and 16).

Standard Switch

If the standard switch (Pin 7) is in position 'low' (for AM sound), the AGC is operating as an average level detector. In position 'open' or 'high' (for FM/NICAM sound), the AGC is a peak value detector.

Internal Voltage Stabilizer

The internal bandgap reference voltage (4.25 V at Pin 4) ensures constant performance, independent of supply voltage and temperature.

FPLL, VCO

The FPLL (frequency-phase-locked loop) circuit consists of a frequency detector and a phase detector to generate a control voltage for the VCO tuning. In locked mode the VCO is controlled by the phase detector while in unlocked mode, the frequency detector is superimposed. The VCO operates with an external resonance circuit (L and C parallel) and is controlled by integrated varicaps.

A practicable VCO alignment of the external coil is the adjustment of the loop filter voltage (Pin 5) to 2.3 V. At this value, capture and hold range are centered.

AM Demodulator

The alignment-free AM demodulator is realized by a synchronous detector. The modulated IF signal from the wideband IF amplifier output is multiplied in phase with the limited SIF signal to remove the AM. Then, the resulting AF signal of the demodulator output is fed to the output amplifier and to the AGC stage.

Quasi-Split-Sound (QSS) Mixer

The QSS mixer is realized by a multiplier circuit. The IF signal (FM/NICAM) is converted in the intercarrier frequency by means of a quadrature signal from the generated picture carrier provided by the PLL. The intercarrier signal is fed via an output amplifier to Pin 12.

Mute Switch

AM sound output (Pin 6) can be muted in pulling mute switch (Pin 10) to 'low'.

Pin Description

Pin	Symbol	Function
1, 2	$V_{i1,IF}$	IF input 1 (symmetrical)
3	C_{AGC}	Capacitor for AGC time constant
4	C_{REF}	Capacitor for internal reference voltage
5	LF	Loop filter
6	$V_{o,AM}$	AF output (AM sound)
7	$V_{sw,AGC}$	Standard switch
8, 9	V_{VCO}	VCO circuit
10	$V_{sw,mute}$	Mute switch
11	$V_{sw,IF}$	IF input switch IF1 / IF2
12	$V_{o,FM}$	Intercarrier output (FM sound)
13	GND	Ground
14	V_S	Supply voltage (5 V)
15, 16	$V_{i2,IF}$	IF input 2 (symmetrical)

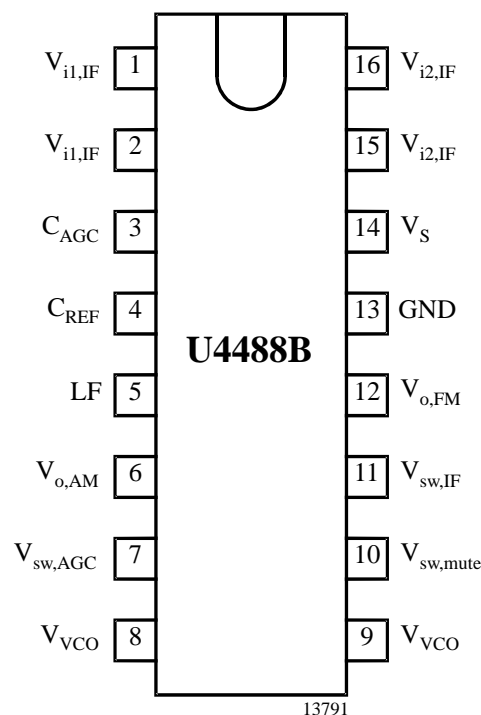

Figure 2. Pinning

Absolute Maximum Ratings

Reference point Pin 13, unless otherwise specified

Parameters	Symbol	Value	Unit
Supply voltage range Pin 14	V_S	4.5 to 9.0	V
Supply current Pin 14	I_S	55	mA
Power dissipation ($V_S = 9\text{ V}$)	P	500	mW
Output currents Pins 6 and 12	I_{out}	5	mA
External voltages Pins 1, 2, 3, 4, 6, 12, 15 and 16 Pins 5, 8 and 9 Pins 7, 10 and 11	V_{ext}	+ 4.5	V
		+ 3.5	V
		V_S	V
Junction temperature	T_j	+125	°C
Operating temperature range	T_{amb}	0 to +85	°C
Storage temperature	T_{stg}	-25 to +125	°C
Electrostatic handling * all pins	V_{ESD}	± 300	V

*) Equivalent to discharging a 200-pF capacitor through a 0-Ω resistor

Thermal Resistance

Parameters	Symbol	Value	Unit
Junction ambient when soldered to PCB	R_{thJA}	60	K/W

Electrical Characteristics

$V_S = +5\text{ V}$, $T_{\text{amb}} = +25^\circ\text{C}$; reference point Pin 13, unless otherwise specified

Parameters	Test Conditions / Pins	Symbol	Min.	Typ.	Max.	Unit
DC-supply (Pin 14)						
Supply voltage		V_S	4.5	5.0	9.0	V
Supply current	$v_{\text{in}}=10\text{ mV}$ or $V_3 = 2\text{ V}$	I_S		40		mA
IF-input (Pins 1 and 2 resp. 15 and 16)						
Minimum IF input signal	Output signal: -3 dB	v_{in}		50		μV_{rms}
Maximum IF input signal	Output signal: +1 dB	v_{in}	70	100		mV_{rms}
Input impedance	(See note 1)	R_{in}		1.2		$\text{k}\Omega$
Input capacitance	(See note 1)	C_{in}		2		pF
IF input switch (Pin 11)						
Switching voltage: IF input 1	Inputs: Pins 1 and 2	V_{swIF1}		open		
Switching voltage: IF input 2	Inputs: Pins 15 and 16	V_{swIF2}	0		1.5	V
Switching current		I_{sw}		-50		μA
SIF-AGC (Pin 3)						
IF gain control range		G_V	60	65		dB
AGC capacitor		C_{AGC}		4.7		μF
FPLL and VCO (Pins 5, 8 and 9)						
Max. oscillator frequency	For carrier generation	f_{VCO}	70			MHz
Vision carrier capture range	$f_{\text{VCO}} = 38.9\text{ MHz}$ $C_{\text{VCO}} = 6.2\text{ pF}$	Δf_{cap}	± 1.5	± 2		MHz
Oscillator drift (free running) as function of temperature	$\Delta T_{\text{amb}} = 55^\circ\text{C}$, $f_{\text{VCO}} = 38.9\text{ MHz}$ $C_{\text{VCO}} = 6.2\text{ pF}$, (see note 2)	$\Delta f/\Delta T$			-0.3	%
Standard switch (Pin 7)						
Switching voltage for mode 1: FM/NICAM sound	Peak value control (see note 3)	V_{sw1}	2.0		V_S	V
Switching voltage for mode 2: AM sound	Average level control	V_{sw2}	0		1.5	V
Switching current		I_{sw}		± 100		μA
AM mute switch (Pin 10)						
Switching voltage	AM output active	V_{mute1}		open		
Switching voltage	AM output switched off	V_{mute2}	0		1.5	V
Switching current		I_{mute}		-100		μA

Notes

1. This parameter is given as an application information and not tested during production
2. The oscillator drift is related to the picture carrier frequency, with external temperature compensated LC circuit
3. Without external control voltage (Pin 7 open), the IC automatically operates in mode 1

Electrical Characteristics (continued)

$V_S = +5\text{ V}$, $T_{\text{amb}} = +25^\circ\text{C}$; reference point Pin 13, unless otherwise specified

Parameters	Test Conditions / Pins	Symbol	Min.	Typ.	Max.	Unit
Intercarrier output (Pin 12) (see note 4)						
DC output voltage		V_{DC}		2		V
Output resistance	(See note 1)	R_{out}			200	Ω
Intercarrier output signal	$v_{\text{in}} = 10\text{ mV}$ 5.5 MHz output signal	V_{out}	100	150		mV_{rms}
Intercarrier bandwidth	-1 dB -3 dB	B		tbd tbd		MHz MHz
Weighted signal-to-noise ratio (CCIR 468)	B/G mod. VIF signal: $v_{\text{in}} = 10\text{ mV}$; FM dev. = $\pm 27\text{ kHz}$; $f_{\text{mod}} = 1\text{ kHz}$; tested with U2860B; Black screen: Channel 1/2 Color bar: Channel 1/2			60/58 58/56		dB dB
Ripple rejection	Tested from Pin 14 to 12 (see note 1)	RR	35			dB
Allowable AC output peak current		I_{AC}			± 0.7	mA
Allowable DC output current		I_{DC}			-2	mA
AF output – AM (Pin 6) (see note 5)						
DC output voltage		V_{DC}		2.2		V
Output resistance	(See note 1)	R_{out}			150	Ω
AF output signal	$m = 54\%$	v_{oAF}		500		mV_{rms}
AF bandwidth	-3 dB	B		tbd		kHz
Total harmonic distortion	$m = 54\%$ $f_{\text{mod}} = 1\text{ kHz}, 12.5\text{ kHz}$	THD		1	2	%
Weighted signal-to-noise ratio (CCIR 468)	Reference: $m = 54\%$; $f_{\text{mod}} = 1\text{ kHz}$	S/N		56		dB
Ripple rejection	Tested from Pin 14 to 6 (see note 1)	RR	28			dB
Allowable AC output peak current		I_{AC}			± 0.3	mA
Allowable DC output current		I_{DC}			-1	mA

Notes

1. This parameter is given as an application information and is not tested during production
2. The oscillator drift is related to the picture carrier frequency, with external temperature compensated LC circuit
3. Without external control voltage (Pin 7 open), the IC automatically operates in mode 1
4. Picture carrier $PC = 38.9\text{ MHz}$; sound carrier $SC_1 = 33.4\text{ MHz}$, $SC_2 = 33.16\text{ MHz}$;
 $PC/SC_1 = 13\text{ dB}$; $PC/SC_2 = 20\text{ dB}$; PC unmodulated (equivalent to sync peak level)
5. Sound carrier $SC = 32.4\text{ MHz}$, modulated with $f_{\text{mod}} = 1\text{ kHz}$, $m = 54\%$; $v_{\text{in}} = 10\text{ mV}$

Internal Pin Configuration

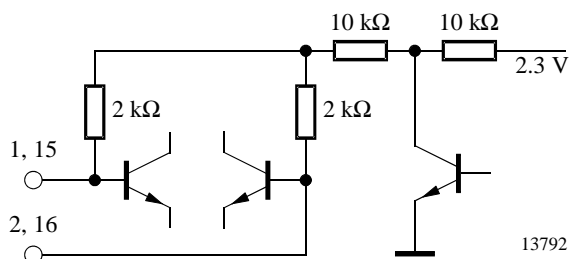

Figure 4. Sound IF inputs (Pins 1, 2 resp. 15,16)

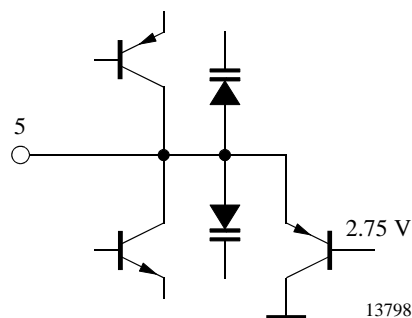

Figure 7. Loop filter (Pin 5)

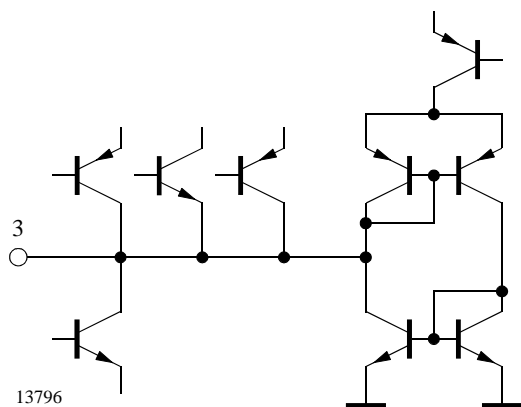

Figure 5. AGC time constant (Pin 3)

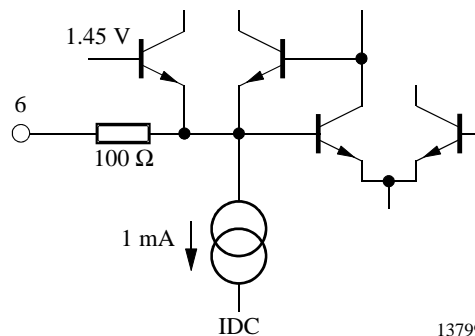

Figure 8. AM output (Pin 6)

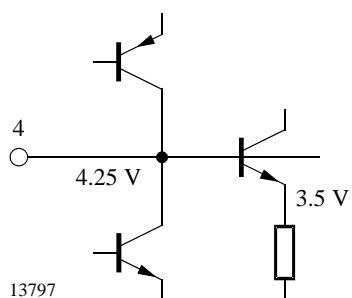

Figure 6. Internal reference voltage (Pin 4)

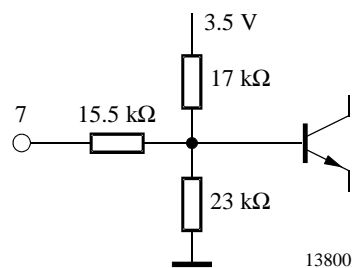

Figure 9. AGC switch (Pin 7)

Internal Pin Configuration

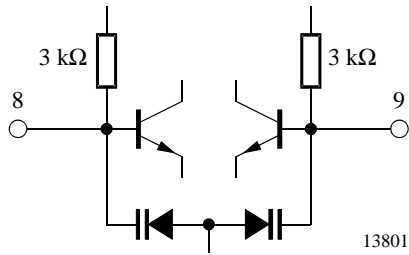

Figure 10. VCO (Pins 8 and 9)

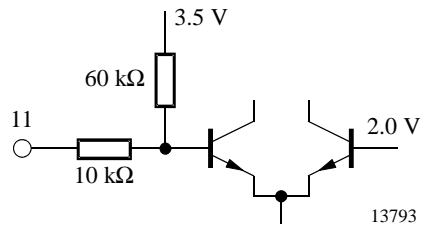

Figure 12. IF input switch (Pin 11)

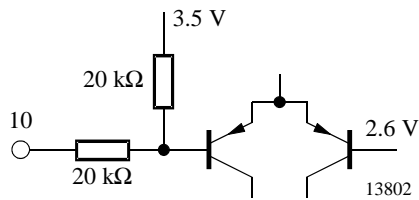

Figure 11. Mute switch (Pin 10)

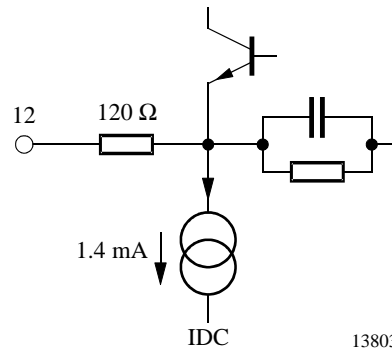
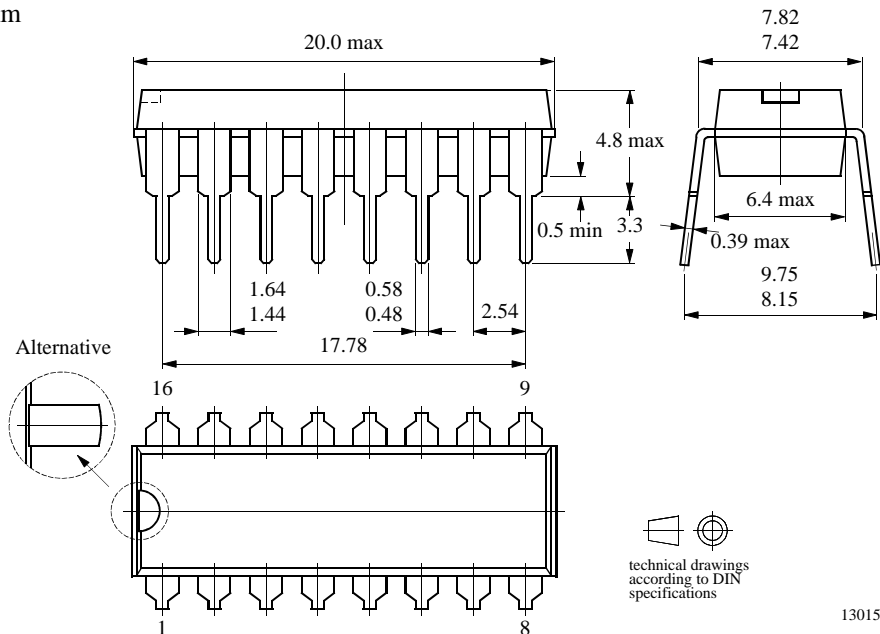

Figure 13. Inter-carrier output (Pin 12)

Package Information

Package DIP16

Dimensions in mm



13015

Ozone Depleting Substances Policy Statement

It is the policy of **TEMIC TELEFUNKEN microelectronic GmbH** to

1. Meet all present and future national and international statutory requirements.
2. Regularly and continuously improve the performance of our products, processes, distribution and operating systems with respect to their impact on the health and safety of our employees and the public, as well as their impact on the environment.

It is particular concern to control or eliminate releases of those substances into the atmosphere which are known as ozone depleting substances (ODSs).

The Montreal Protocol (1987) and its London Amendments (1990) intend to severely restrict the use of ODSs and forbid their use within the next ten years. Various national and international initiatives are pressing for an earlier ban on these substances.

TEMIC TELEFUNKEN microelectronic GmbH semiconductor division has been able to use its policy of continuous improvements to eliminate the use of ODSs listed in the following documents.

1. Annex A, B and list of transitional substances of the Montreal Protocol and the London Amendments respectively
2. Class I and II ozone depleting substances in the Clean Air Act Amendments of 1990 by the Environmental Protection Agency (EPA) in the USA
3. Council Decision 88/540/EEC and 91/690/EEC Annex A, B and C (transitional substances) respectively.

TEMIC can certify that our semiconductors are not manufactured with ozone depleting substances and do not contain such substances.

We reserve the right to make changes to improve technical design and may do so without further notice.

Parameters can vary in different applications. All operating parameters must be validated for each customer application by the customer. Should the buyer use TEMIC products for any unintended or unauthorized application, the buyer shall indemnify TEMIC against all claims, costs, damages, and expenses, arising out of, directly or indirectly, any claim of personal damage, injury or death associated with such unintended or unauthorized use.

TEMIC TELEFUNKEN microelectronic GmbH, P.O.B. 3535, D-74025 Heilbronn, Germany
Telephone: 49 (0)7131 67 2831, Fax number: 49 (0)7131 67 2423