

Overload Monitoring with Resistive Load, $V_T = 44.5 \text{ mV}$

Description

The IC U4793B in bipolar circuit, is designed to monitor overload or a short circuit in automotive or industrial applications. The threshold is tied to $V_{4,6} = V_S - V_T$ whereas $V_T = 44.5 \text{ mV}$. It is independent of the supply voltage, V_S . If the voltage drop across shunt resistor, R_{sh} , exceeds this value, the output is turned on, otherwise the output is turned off.

Without supply voltage or open input Pin 8, the output is turned off. The output breakdown voltage is determined by the Z-diodes Z_3 and Z_5 with a typical value of $V_Z = 22 \text{ V}$.

A not used comparator input must be connected to Pin 7.

Features

- 10 kV – ESD protection
- Two comparators with common reference
- Tight threshold tolerance
- Constant threshold
- NPN output
- Interference and damage–protection according to VDE 0839
- EMI protection
- Reversal polarity protection
- Load-dump protection

Ordering Information

Extended Type Number	Package	Remarks
U4793B	DIP8	
U4793B–FP	SO8	

Block Diagram

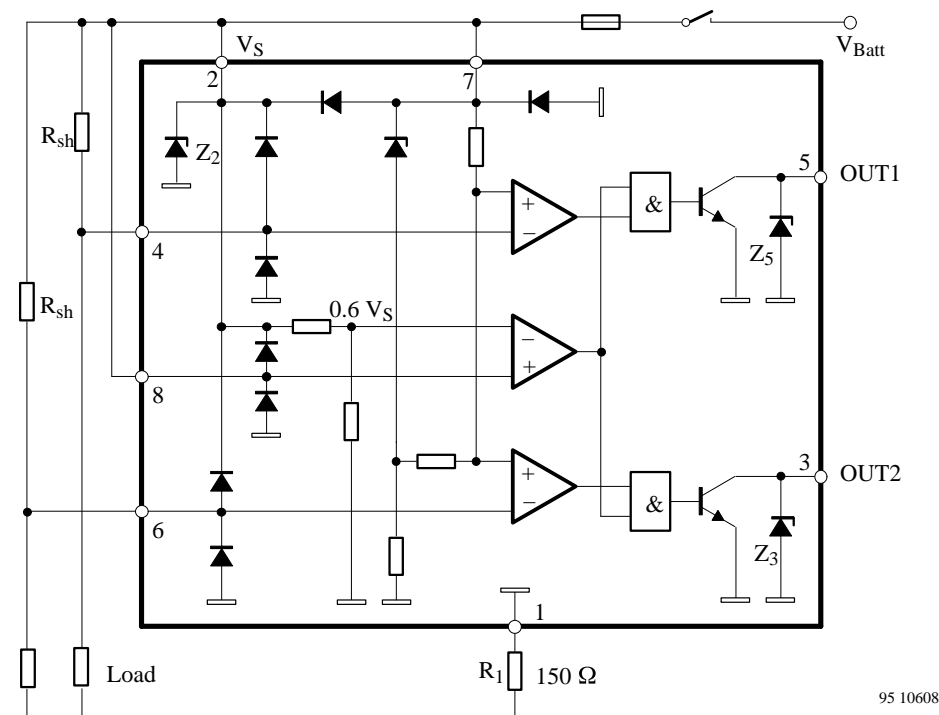
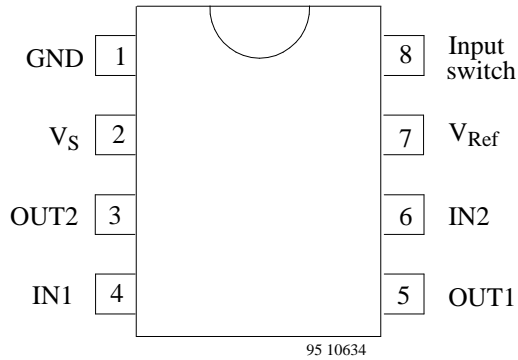

Figure 1. Schematic and application circuit

Pin Description



Pin	Symbol	Function
1	GND	Reference point, ground
2	V_S	Supply voltage
3	OUT2	Output 2
4	IN1	Input 1
5	OUT1	Output 1
6	IN2	Input 2
7	V_{Ref}	Reference voltage
8	Input	Input switch

Absolute Maximum Ratings

Parameters	Symbol	Value	Unit
Supply voltage Pin 2, 7	V_S	16.5	V
Current consumption $t = 2$ ms, measured at Pin 1 (GND) Pin 1	I_1	1.5	A
Output current Pin 3, 5	$I_{3,5}$	20	mA
Input voltage reference point Pin 7 Pin 4, 6	$-V_{4,6}$	6	V
Power dissipation $T_{amb} = 95$ °C DIP 8 SO 8	P_{tot}	420 360	mW
	P_{tot}	690 560	mW
Ambient temperature range	T_{amb}	-40 to +95	°C
Storage temperature range	T_{stg}	-55 to +125	°C
Junction temperature	T_j	150	°C

Thermal Resistance

Parameters	Symbol	Value	Unit
Junction ambient DIP8 SO8	R_{thJA}	110	K/W
	R_{thJA}	160	K/W

Electrical Characteristics

$V_S = 9$ to 15 V, $T_{amb} = -40$ to $+95$ °C, figure 1, unless otherwise specified

Parameters	Test Conditions / Pin	Symbol	Min	Typ	Max	Unit
Supply voltage	Pin 2,7	V_S	9		15	V
Internal Z-diode Z_2	Pin 2	V_Z	20			V
Current consumption	$V_S = 12$ V Pin 1 measured at Pin 1 (GND)	I_1		4.5	6	mA
Output saturation voltage	$V_S = 9$ V, $I_{3,5} = 10$ mA $T_{amb} = 25$ °C Pin 3,5	V_{sat}			0.5	V
Output Z-diodes Z_3, Z_5	Pin 3,5	V_Z	21			V
Control signal threshold	$I_{3,5} = 1$ mA, figure 3 Pin 4,6 $T_{amb} = 25$ °C	$-V_T$	43	44.5	46	mV
Temperature coefficient of control signal threshold		TC		15		μ V/K
Threshold voltage	Switch identification Pin 8	V_8		$0.6 V_S$		V
Input currents	Pin 4,6	I_I		100		nA
	Pin 8			5		μ A
Delay time	Switch-on High to low Pin 3,5	$t_{d(on)}$		6		μ s
	Switch-off Low to high	$t_{d(off)}$		30		μ s

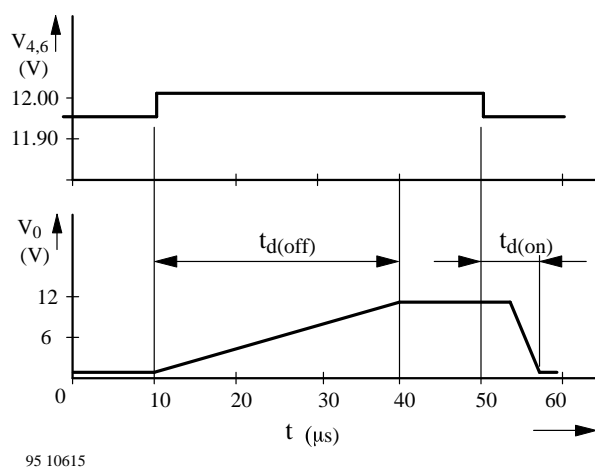

Figure 2. Timing diagram

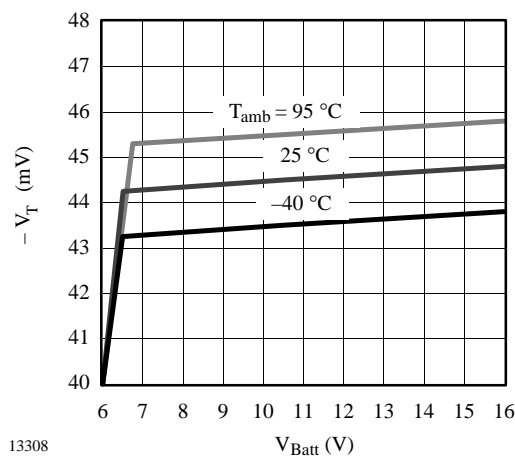
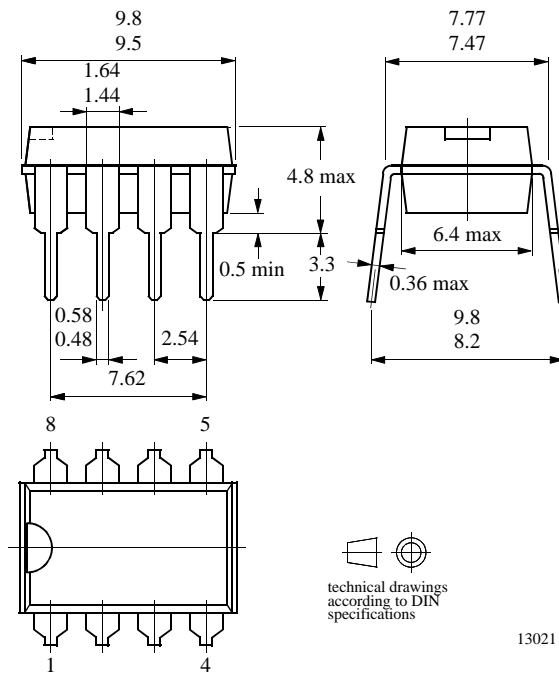

Figure 3. Threshold voltage = f (V_{Batt} and temperature)

Package Information

Package DIP8

Dimensions in mm



Package SO8

Dimensions in mm

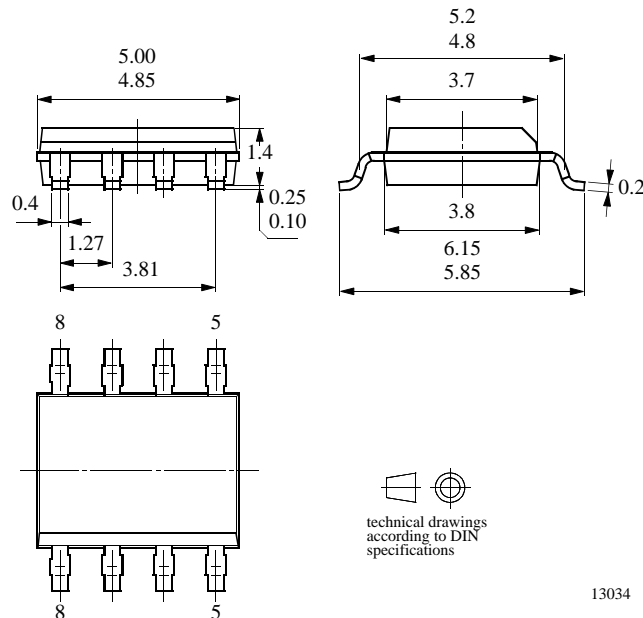

Ozone Depleting Substances Policy Statement

It is the policy of **TEMIC TELEFUNKEN microelectronic GmbH** to

1. Meet all present and future national and international statutory requirements.
2. Regularly and continuously improve the performance of our products, processes, distribution and operating systems with respect to their impact on the health and safety of our employees and the public, as well as their impact on the environment.

It is particular concern to control or eliminate releases of those substances into the atmosphere which are known as ozone depleting substances (ODSs).

The Montreal Protocol (1987) and its London Amendments (1990) intend to severely restrict the use of ODSs and forbid their use within the next ten years. Various national and international initiatives are pressing for an earlier ban on these substances.

TEMIC TELEFUNKEN microelectronic GmbH semiconductor division has been able to use its policy of continuous improvements to eliminate the use of ODSs listed in the following documents.

1. Annex A, B and list of transitional substances of the Montreal Protocol and the London Amendments respectively
2. Class I and II ozone depleting substances in the Clean Air Act Amendments of 1990 by the Environmental Protection Agency (EPA) in the USA
3. Council Decision 88/540/EEC and 91/690/EEC Annex A, B and C (transitional substances) respectively.

TEMIC can certify that our semiconductors are not manufactured with ozone depleting substances and do not contain such substances.

We reserve the right to make changes to improve technical design and may do so without further notice.

Parameters can vary in different applications. All operating parameters must be validated for each customer application by the customer. Should the buyer use TEMIC products for any unintended or unauthorized application, the buyer shall indemnify TEMIC against all claims, costs, damages, and expenses, arising out of, directly or indirectly, any claim of personal damage, injury or death associated with such unintended or unauthorized use.

TEMIC TELEFUNKEN microelectronic GmbH, P.O.B. 3535, D-74025 Heilbronn, Germany
Telephone: 49 (0)7131 67 2831, Fax number: 49 (0)7131 67 2423