



Automotive Lamp-outage Monitor IC

U479B

Features

- 2-kV ESD Protection
- Two Comparators with Common Reference
- Tight Threshold Tolerance
- Threshold Matched to PTC Characteristic of Incandescent Lamps
- Temperature Compensated
- NPN Output
- Interference and Damage-protection According to VDE 0839
- EMI Protection
- Reversal Polarity Protection
- Load-dump Protection

Description

The monolithic integrated bipolar circuit, U479B, is designed as a monitor for lamp failure in automobiles. The comparator threshold is matched to the PTC characteristic of incandescent lamps. The threshold is tied to $V_{4,6} = V_S - V_T$ where $V_T = 8$ mV.

If the voltage drop across the shunt resistor, R_{sh} , exceeds 8 mV, the output is turned off, otherwise, the output is turned on. Without supply voltage or open input pin 8, the output is turned off. A comparator input, which is not used, must be connected to pin 7.

Figure 1. Schematic and Application Circuit

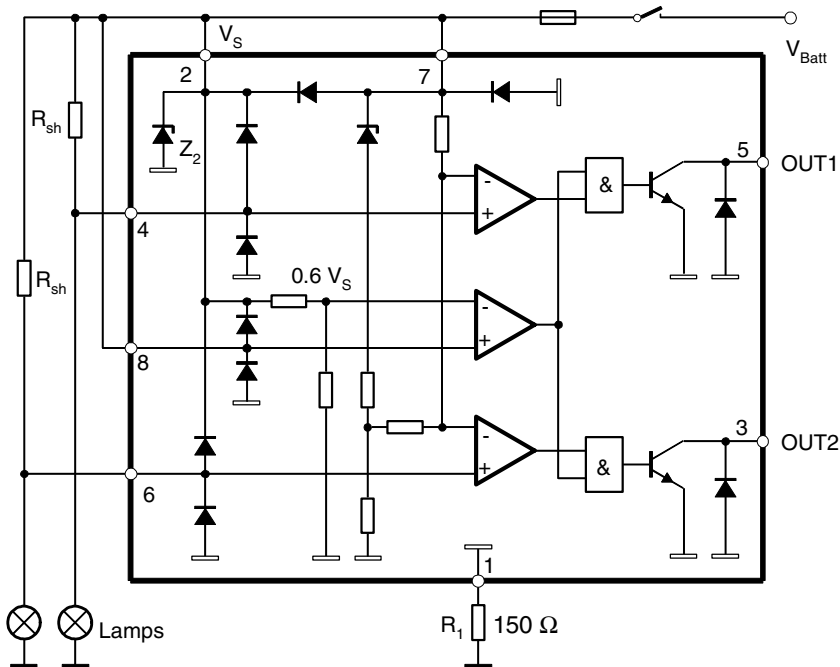

Pin Configuration

Figure 2. Pinning DIP8/SO8

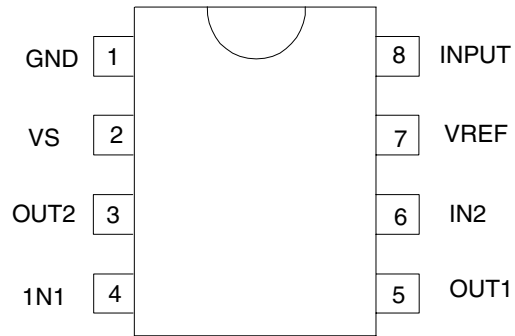

Pin Description

Pin	Symbol	Function
1	GND	Reference point, ground
2	VS	Supply voltage
3	OUT2	Output 2
4	IN1	Input 1
5	OUT1	Output 1
6	IN2	Input 2
7	VREF	Reference voltage
8	INPUT	Input switch

Absolute Maximum Ratings

Stresses beyond those listed under “Absolute Maximum Ratings” may cause permanent damage to the device. This is a stress rating only and functional operation of the device at these or any other conditions beyond those indicated in the operational sections of this specification is not implied. Exposure to absolute maximum rating conditions for extended periods may affect device reliability.

Parameters	Pin	Symbol	Value	Unit
Supply voltage	2, 7	V_S	16.5	V
Current consumption, $t = 2$ ms	1	I_1	1.5	A
Output current	3, 5	$I_{3,5}$	20	mA
Input voltage Reference point pin 7	4, 6	$-V_{4,6}$	6	V
Power dissipation				
$T_{amb} = 95^{\circ}\text{C}$	DIP8	P_{tot}	420	mW
	SO8	P_{tot}	360	mW
$T_{amb} = 60^{\circ}\text{C}$	DIP8	P_{tot}	690	mW
	SO8	P_{tot}	560	mW
Ambient temperature range		T_{amb}	-40 to +95	$^{\circ}\text{C}$
Storage temperature range		T_{stg}	-55 to +125	$^{\circ}\text{C}$
Junction temperature		T_j	150	$^{\circ}\text{C}$

Thermal Resistance

Parameters		Symbol	Value	Unit
Junction ambient	DIP8	R_{thJA}	110	K/W
	SO8	R_{thJA}	160	K/W

Electrical Characteristics

$V_S = 9$ to 15 V, $T_{amb} = -40$ to $+95^\circ\text{C}$, Figure 1 on page 1, unless otherwise specified.

Parameters	Test Conditions	Pin	Symbol	Min.	Typ.	Max.	Unit
Supply voltage		2, 7	V_S	9		15	V
Internal Z-diode Z_2		2	V_Z	20			V
Current consumption	$V_S = 12$ V	1	I_1		4.5	6	mA
Output saturation voltage	$V_S = 9$ V, $I_{3,5} = 10$ mA $T_{amb} = 25^\circ\text{C}$	3, 5	V_{sat}			0.5	V
Control signal threshold	Reference point $V_{Pin\ 7}$ $I_{3,5} = 3$ mA	4, 6	$-V_T$	6.5	8	9.5	mV
	$V_S = 12$ V $V_S = 15$ V		$-V_T$	7.8	9.3	10.8	mV
Voltage drift	$\Delta V = \frac{V_{T(15\text{ V})} - V_{T(12\text{ V})}}{15\text{ V} - 12\text{ V}}$		ΔV		0.45		mV/V
Threshold voltage	Switch identification	8	V_8		$0.6 V_S$		V
Input currents	Input 1/input 2	4, 6	I_1		100		nA
	Input switch	8	I_1		5		μA
Delay time	Switch-on, high to low	3, 5	$t_{d(on)}$		6		μs
	Switch-off, low to high		$t_{d(off)}$		30		μs

Figure 3. Delay Times

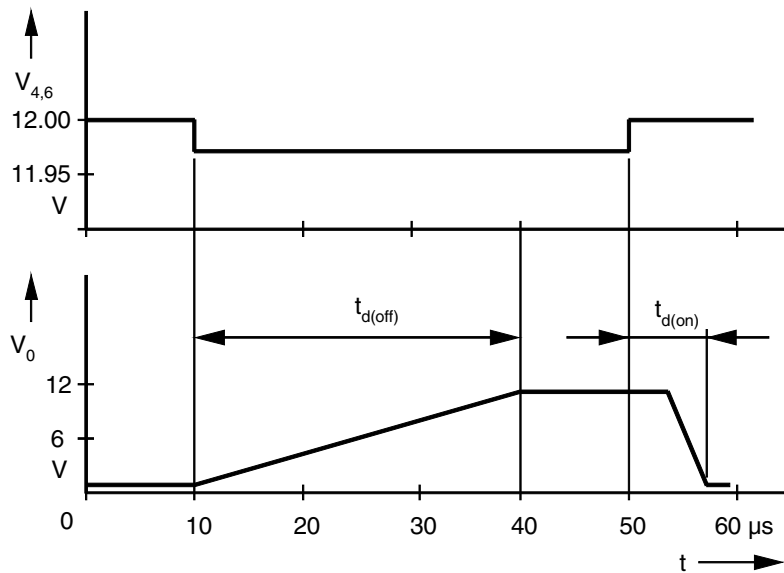

Ordering Information

Extended Type Number	Package	Remarks
U479B	DIP8	–
U479B-FP	SO8	–

Package Information

Package DIP8

Dimensions in mm

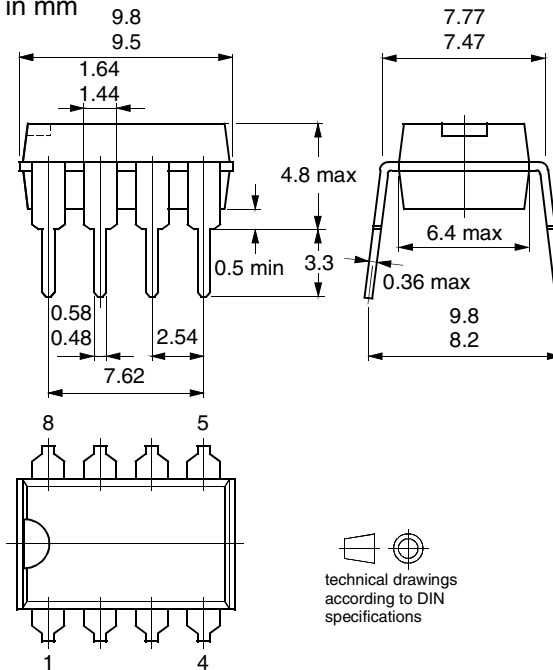

Package SO8
Dimensions in mm

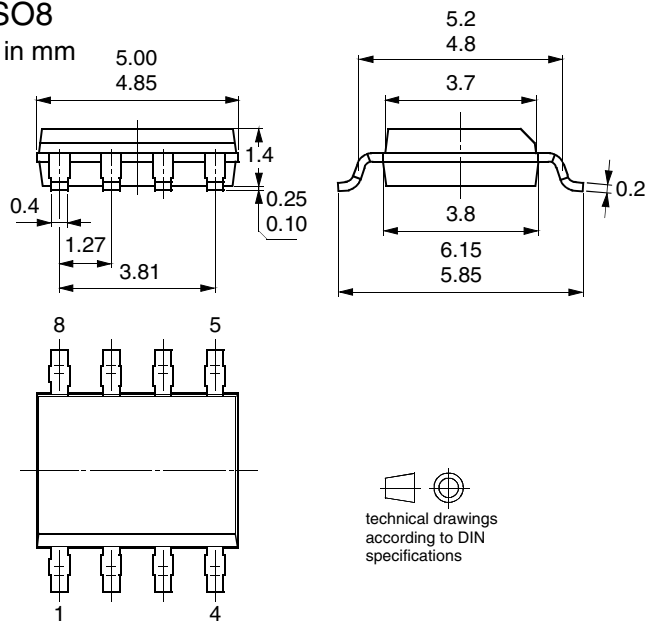



Atmel Corporation

2325 Orchard Parkway
San Jose, CA 95131, USA
Tel: 1(408) 441-0311
Fax: 1(408) 487-2600

Regional Headquarters

Europe

Atmel Sarl
Route des Arsenalux 41
Case Postale 80
CH-1705 Fribourg
Switzerland
Tel: (41) 26-426-5555
Fax: (41) 26-426-5500

Asia

Room 1219
Chinachem Golden Plaza
77 Mody Road Tsimshatsui
East Kowloon
Hong Kong
Tel: (852) 2721-9778
Fax: (852) 2722-1369

Japan

9F, Tonetsu Shinkawa Bldg.
1-24-8 Shinkawa
Chuo-ku, Tokyo 104-0033
Japan
Tel: (81) 3-3523-3551
Fax: (81) 3-3523-7581

Atmel Operations

Memory

2325 Orchard Parkway
San Jose, CA 95131, USA
Tel: 1(408) 441-0311
Fax: 1(408) 436-4314

Microcontrollers

2325 Orchard Parkway
San Jose, CA 95131, USA
Tel: 1(408) 441-0311
Fax: 1(408) 436-4314

La Chantrerie
BP 70602
44306 Nantes Cedex 3, France
Tel: (33) 2-40-18-18-18
Fax: (33) 2-40-18-19-60

ASIC/ASSP/Smart Cards

Zone Industrielle
13106 Rousset Cedex, France
Tel: (33) 4-42-53-60-00
Fax: (33) 4-42-53-60-01

1150 East Cheyenne Mtn. Blvd.
Colorado Springs, CO 80906, USA
Tel: 1(719) 576-3300
Fax: 1(719) 540-1759

Scottish Enterprise Technology Park
Maxwell Building
East Kilbride G75 0QR, Scotland
Tel: (44) 1355-803-000
Fax: (44) 1355-242-743

RF/Automotive

Theresienstrasse 2
Postfach 3535
74025 Heilbronn, Germany
Tel: (49) 71-31-67-0
Fax: (49) 71-31-67-2340

1150 East Cheyenne Mtn. Blvd.
Colorado Springs, CO 80906, USA
Tel: 1(719) 576-3300
Fax: 1(719) 540-1759

Biometrics/Imaging/Hi-Rel MPU/ High Speed Converters/RF Datacom

Avenue de Rochepleine
BP 123
38521 Saint-Egreve Cedex, France
Tel: (33) 4-76-58-30-00
Fax: (33) 4-76-58-34-80

Literature Requests

www.atmel.com/literature

Disclaimer: Atmel Corporation makes no warranty for the use of its products, other than those expressly contained in the Company's standard warranty which is detailed in Atmel's Terms and Conditions located on the Company's web site. The Company assumes no responsibility for any errors which may appear in this document, reserves the right to change devices or specifications detailed herein at any time without notice, and does not make any commitment to update the information contained herein. No licenses to patents or other intellectual property of Atmel are granted by the Company in connection with the sale of Atmel products, expressly or by implication. Atmel's products are not authorized for use as critical components in life support devices or systems.

© Atmel Corporation 2003. All rights reserved.

Atmel® and combinations thereof are the registered trademarks of Atmel Corporation or its subsidiaries.

Other terms and product names may be the trademarks of others.



Printed on recycled paper.

This datasheet has been download from:

www.datasheetcatalog.com

Datasheets for electronics components.