Features

- Temperature and Voltage Compensated Frequency
- Warning Indication of Lamp Failure by Means of Frequency Doubling can be Disabled
- Voltage Dependence of the Car Indicator Lamps Compensated for Lamp Failure
- Relay Output with High Current Carrying Capacity and Low Saturation Voltage
- Minimum Lamp Load for Flasher Operation $\geq 1W$
- Load-dump Protection
- Very Low Susceptibility to EMI
- Protection According to ISO/TR 7637/1 Level 4



1. Description

The design of the U6433B is similar to that of U6043B, both devices have the same excellent EMC (Electro Magnetic Capability) and protection features. The U6433B includes an additional 8-mV comparator and a logical connection with the frequency doubling stage. This combination can be used for a hazard switch which bypasses the external shunt resistor to disable the frequency doubling. This feature is especially important with respect to the US automotive industry. During direction mode the U6433B works like other flashers, that is, frequency doubling in the case of lamp outage.



**Flasher, 18-m Ω
Shunt,
Frequency
Doubling
Disabling**

U6433B

Rev. 4810B-AUTO-10/05



Figure 1-1. Block Diagram

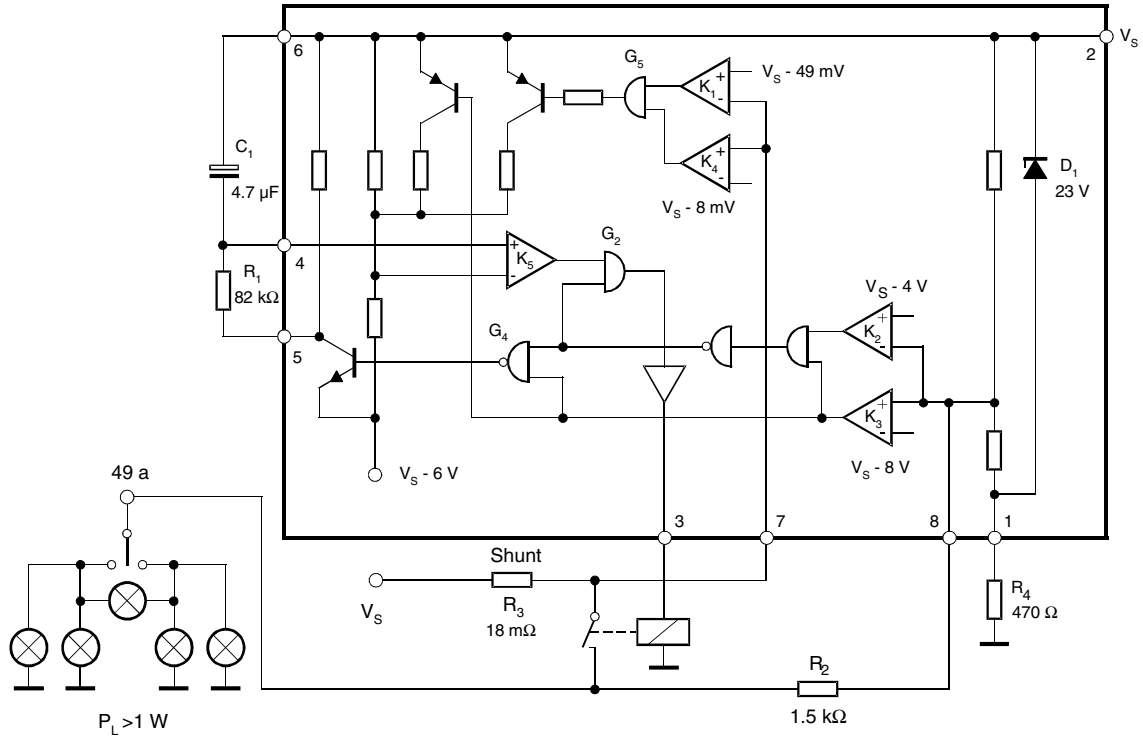

2. Pin Configuration

Figure 2-1. Pinning SO8

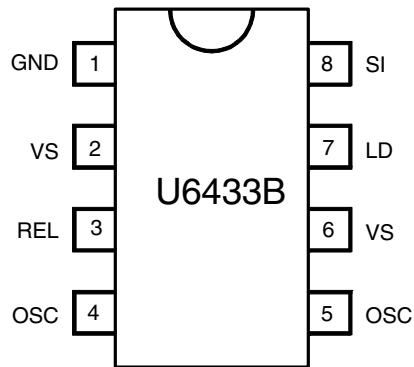

Table 2-1. Pin Description

Pin	Symbol	Function
1	GND	IC ground
2	VS	Supply voltage
3	REL	Relay driver
4	OSC	Oscillator
5	OSC	Oscillator
6	VS	Supply voltage
7	LD	Lamp failure detection
8	SI	Start input (49a)

3. Functional Description

3.1 Pin 1, GND

The integrated circuit is protected against damage via resistor R_4 to ground (–31) in the case of battery reversal.

An integrated protection circuit together with external resistances R_2 and R_4 limits the current pulses in the IC.

3.2 Pin 2, Supply Voltage, V_S – Power

The arrangement of the supply connections to pin 2 must be so as to ensure that, on the connection printed circuit board (PCB), the resistance of V_S to pin 6 is lower than that to pin 2.

3.3 Pin 3, Relay Control Output (Driver)

The relay control output is a high-side driver with a low saturation voltage and is capable of driving a typical automotive relay with a minimum coil resistance of 60Ω .

3.4 Pins 4 and 5, Oscillator

The flashing frequency, f_1 , is determined by the R_1C_1 components as follows (see [Figure 1-1 on page 2](#)):

$$f_1 \approx \frac{1}{R_1 \times C_1 \times 1.5} \text{ Hz}$$

where

$$C_1 \leq 47 \mu\text{F}$$

$$R_1 + 6.8 \text{ k}\Omega \text{ to } 510 \text{ k}\Omega$$

In the case of a lamp outage (see pin 7) the oscillator frequency is switched to the lamp outage frequency f_2 with $f_2 \approx 2.2 \times f_1$.

Duty cycle in normal flashing mode: 50%

Duty cycle in lamp outage mode: 40% (bright phase)

3.5 Pin 6, Supply Voltage, Sense

For accurate monitoring via the shunt resistor, a minimized layer resistance from point V_S /shunt to pin 6 is recommended.

3.6 Pin 7, Lamp Outage Detection

3.6.1 Control Signal Threshold 1 (49-mV Comparator K1)

The detection point for lamp failure can be calculated from the control signal threshold, typically 49 mV with $V_S = 12\text{V}$. With a measuring resistance of $R_3 = 18 \text{ m}\Omega$, the frequency change-over is reached at a lamp load of $21\text{W} + 11.4\text{W}$. The variation of the control signal threshold supply voltage takes into account the PTC characteristic of filament lamps.

3.6.2 Control Signal Threshold 2 (8-mV Comparator K4)

A voltage drop between 49 mV to 8 mV at R_3 shunt resistor lets the flasher work in frequency doubling mode.

If the voltage drop decreases to a value below $V_{R3MAX} = 8$ mV, frequency doubling is disabled. This can be achieved either with a switch which bypasses the shunt resistor (for example, a special hazard warning switch) or with a small lamp load.

The arrangement of the supply connections to pins 2 and 6 must ensure that, on the connection PCB, the layer resistance from V_S to pin 6 is lower than the resistance to pin 2.

Flasher operation starts with a lamp load of $P_L \geq 1W$.

3.7 Pin 8, Start Input

Start condition for flashing: the voltage at pin 8 has to be below the K3 threshold (flasher switch closed).

Humidity and dirt may decrease the resistance between 49a and GND. If this leakage resistance is > 5 k Ω , the IC is still kept in its off condition. In this case the voltage at pin 8 is between the thresholds of comparators K2 and K3.

During the bright phase the voltage at pin 8 is above the K2 threshold; during the dark phase it is below the K3 threshold.

For proper start conditions, a minimum lamp wattage of 1W is required.

4. Absolute Maximum Ratings

Stresses beyond those listed under “Absolute Maximum Ratings” may cause permanent damage to the device. This is a stress rating only and functional operation of the device at these or any other conditions beyond those indicated in the operational sections of this specification is not implied. Exposure to absolute maximum rating conditions for extended periods may affect device reliability.

Reference point pin 1.

Parameters	Symbol	Value	Unit
Supply voltage, pins 2 and 6	V_S	18	V
Surge forward current $t_p = 0.1$ ms, pins 2 and 6 $t_p = 300$ ms, pins 2 and 6 $t_p = 300$ ms, pin 8	I_{FSM}	1.5 1.0 30.0	A A mA
Output current, pin 3	I_O	0.3	A
Power dissipation $T_{amb} = 95^\circ\text{C}$, SO8 $T_{amb} = 60^\circ\text{C}$, SO8	P_{tot}	340 560	mW mW
Junction temperature	T_j	150	$^\circ\text{C}$
Ambient temperature range	T_{amb}	-40 to +105	$^\circ\text{C}$
Storage temperature range	T_{stg}	-55 to +150	$^\circ\text{C}$

5. Thermal Resistance

Parameters	Symbol	Value	Unit
Junction ambient SO8	R_{thJA}	160	K/W

6. Electrical Characteristics

Typical values under normal operation of the application circuit shown in [Figure 1-1 on page 2](#), $V_S = 12V$ (pins 2 and 6).
 $T_{amb} = 25^\circ C$, reference point ground (-31), unless otherwise specified.

Parameters	Test Conditions	Symbol	Min.	Typ.	Max.	Unit
Supply voltage range	Pins 2 and 6	V_S	9		16.5	V
Supply current, dark phase	Pins 2 and 6	I_S		4.5	8	mA
Supply current, bright phase	Pins 2 and 6	I_S		7.0	11	mA
Relay output, saturation voltage	$I_O = 150$ mA, $V_S = 9V$, pin 3	V_O			1.0	V
Relay output reverse current	Pin 3	I_O			0.1	mA
Relay coil resistance		R_L	60			Ω
Start delay	First bright phase	t_{on}			10	ms
Frequency determining resistor		R_1	6.8		510	k Ω
Frequency determining capacitor		C_1			47	μF
Frequency tolerance	Normal flashing, basic frequency f_1 not including the tolerances of the external components R_1 and C_1	Δf_1	-5		+5	%
Bright period	Basic frequency f_1 , $V_S = 9V$ to 15V	Δf_1	47		53	%
Bright period	Control frequency f_2 , $V_S = 9V$ to 15V	Δf_2	37		45	%
Frequency increase	Lamp failure, $V_S = 9V$ to 15V	f_2	$2.15 \times f_1$		$2.3 \times f_1$	Hz
Control signal threshold 1	$V_S = 15V$, pin 7 $V_S = 9V$ $V_S = 12V$	V_{R3}	50 43 47	53 45 49	57 47 51	mV
Control signal threshold 2		V_{R3}	2		10	mV
Leakage resistance	49a to GND	R_p			5	k Ω
Lamp load		P_L	1			W

7. Ordering Information

Extended Type Number	Package	Remarks
U6433B-MFPY	SO8	Tubed, Pb-free
U6433B-MFPG3Y	SO8	Taped and reeled, Pb-free

8. Package Information

Package SO8

Dimensions in mm

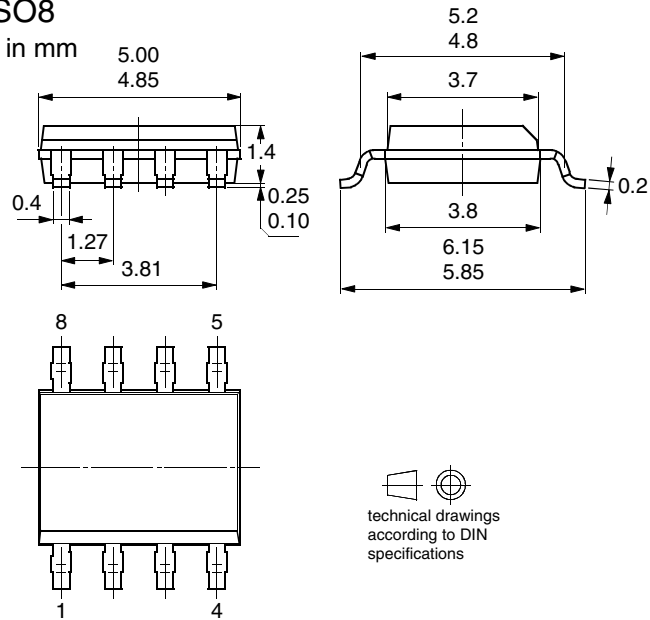

9. Revision History

Please note that the following page numbers referred to in this section refer to the specific revision mentioned, not to this document.

Revision No.	History
4810B-AUTO-08/05	<ul style="list-style-type: none"> Put datasheet in a new template Updated text to new style guide First page: Pb-free logo added Page 7: Ordering Information changed



Atmel Corporation

2325 Orchard Parkway
San Jose, CA 95131, USA
Tel: 1(408) 441-0311
Fax: 1(408) 487-2600

Regional Headquarters

Europe

Atmel Sarl
Route des Arsenaux 41
Case Postale 80
CH-1705 Fribourg
Switzerland
Tel: (41) 26-426-5555
Fax: (41) 26-426-5500

Asia

Room 1219
Chinachem Golden Plaza
77 Mody Road Tsimshatsui
East Kowloon
Hong Kong
Tel: (852) 2721-9778
Fax: (852) 2722-1369

Japan

9F, Tonetsu Shinkawa Bldg.
1-24-8 Shinkawa
Chuo-ku, Tokyo 104-0033
Japan
Tel: (81) 3-3523-3551
Fax: (81) 3-3523-7581

Atmel Operations

Memory

2325 Orchard Parkway
San Jose, CA 95131, USA
Tel: 1(408) 441-0311
Fax: 1(408) 436-4314

Microcontrollers

2325 Orchard Parkway
San Jose, CA 95131, USA
Tel: 1(408) 441-0311
Fax: 1(408) 436-4314

La Chantrerie
BP 70602
44306 Nantes Cedex 3, France
Tel: (33) 2-40-18-18-18
Fax: (33) 2-40-18-19-60

ASIC/ASSP/Smart Cards

Zone Industrielle
13106 Rousset Cedex, France
Tel: (33) 4-42-53-60-00
Fax: (33) 4-42-53-60-01

1150 East Cheyenne Mtn. Blvd.
Colorado Springs, CO 80906, USA
Tel: 1(719) 576-3300
Fax: 1(719) 540-1759

Scottish Enterprise Technology Park
Maxwell Building
East Kilbride G75 0QR, Scotland
Tel: (44) 1355-803-000
Fax: (44) 1355-242-743

RF/Automotive

Theresienstrasse 2
Postfach 3535
74025 Heilbronn, Germany
Tel: (49) 71-31-67-0
Fax: (49) 71-31-67-2340

1150 East Cheyenne Mtn. Blvd.
Colorado Springs, CO 80906, USA
Tel: 1(719) 576-3300
Fax: 1(719) 540-1759

Biometrics/Imaging/Hi-Rel MPU/ High Speed Converters/RF Datacom

Avenue de Rochepleine
BP 123
38521 Saint-Egreve Cedex, France
Tel: (33) 4-76-58-30-00
Fax: (33) 4-76-58-34-80

Literature Requests

www.atmel.com/literature

Disclaimer: The information in this document is provided in connection with Atmel products. No license, express or implied, by estoppel or otherwise, to any intellectual property right is granted by this document or in connection with the sale of Atmel products. **EXCEPT AS SET FORTH IN ATMEL'S TERMS AND CONDITIONS OF SALE LOCATED ON ATMEL'S WEB SITE, ATMEL ASSUMES NO LIABILITY WHATSOEVER AND DISCLAIMS ANY EXPRESS, IMPLIED OR STATUTORY WARRANTY RELATING TO ITS PRODUCTS INCLUDING, BUT NOT LIMITED TO, THE IMPLIED WARRANTY OF MERCHANTABILITY, FITNESS FOR A PARTICULAR PURPOSE, OR NON-INFRINGEMENT. IN NO EVENT SHALL ATMEL BE LIABLE FOR ANY DIRECT, INDIRECT, CONSEQUENTIAL, PUNITIVE, SPECIAL OR INCIDENTAL DAMAGES (INCLUDING, WITHOUT LIMITATION, DAMAGES FOR LOSS OF PROFITS, BUSINESS INTERRUPTION, OR LOSS OF INFORMATION) ARISING OUT OF THE USE OR INABILITY TO USE THIS DOCUMENT, EVEN IF ATMEL HAS BEEN ADVISED OF THE POSSIBILITY OF SUCH DAMAGES.** Atmel makes no representations or warranties with respect to the accuracy or completeness of the contents of this document and reserves the right to make changes to specifications and product descriptions at any time without notice. Atmel does not make any commitment to update the information contained herein. Unless specifically provided otherwise, Atmel products are not suitable for, and shall not be used in, automotive applications. Atmel's products are not intended, authorized, or warranted for use as components in applications intended to support or sustain life.

© Atmel Corporation 2005. All rights reserved. Atmel®, logo and combinations thereof, Everywhere You Are® and others, are registered trademarks or trademarks of Atmel Corporation or its subsidiaries. Other terms and product names may be trademarks of others.



Printed on recycled paper.