



## U74AHC374

CMOS IC

### OCTAL EDGE-TRIGGERED D-TYPE FLIP-FLOPS WITH 3-STATE OUTPUTS

#### DESCRIPTION

The **U74AHC374** is a octal edge-triggered D-type flip-flops with 3-state outputs and it has 8 channels.

When the  $\overline{OE}$  input is low, on the positive transition of the clock (CLK) input, the Q outputs are set to the logic levels of the data (D) inputs.

When the  $\overline{OE}$  input is high, the outputs are in the high-impedance.

To ensure the high-impedance state during power up or power down,  $\overline{OE}$  should be tied to  $V_{CC}$  through a pull-up resistor; the minimum value of the resistor is determined by the current-sinking capability of the driver.

#### FEATURES

- \* Operate from 2V to 5.5V
- \* Max  $t_{PD}$  of 12.7ns at  $V_{CC}=3.3V, C_L=15pF$
- \* Max  $I_{CC}$  of 4uA
- \* Typ  $V_{OL} < 0.36V$  at  $V_{CC}=4.5V, I_o=8mA, T_A=25^\circ C$
- \* Typ  $V_{OH} > 3.94V$  at  $V_{CC}=4.5V, I_o=-8mA, T_A=25^\circ C$

#### ORDERING INFORMATION

Ordering Number	Package	Packing
U74AHC374G-P20-R	TSSOP-20	Tape Reel

<p>U74AHC374G-P20-R</p> <ul style="list-style-type: none"> <li>(1) Packing Type</li> <li>(2) Package Type</li> <li>(3) Green Package</li> </ul>	<ul style="list-style-type: none"> <li>(1) R: Tape Reel</li> <li>(2) P20: TSSOP-20</li> <li>(3) G: Halogen Free and Lead Free</li> </ul>
---	--

#### MARKING

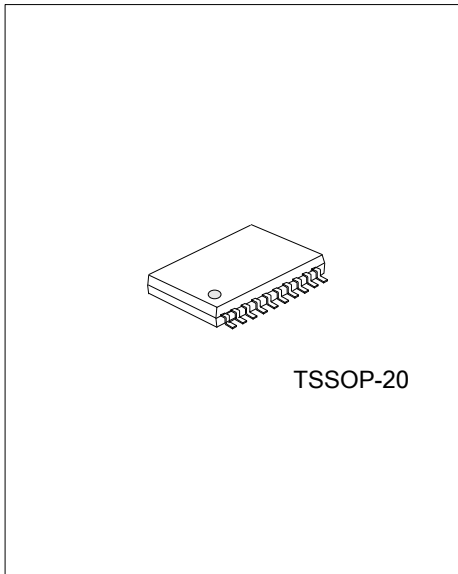
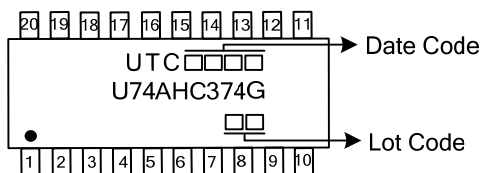

TSSOP-20

■ PIN CONFIGURATION

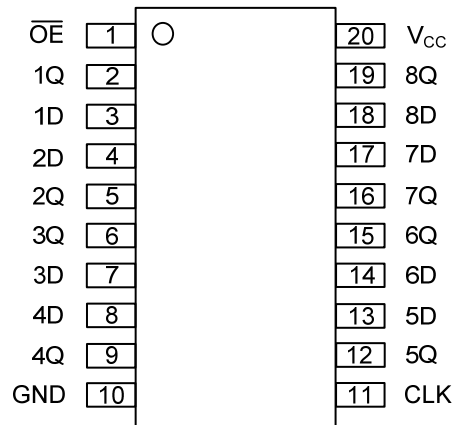

■ FUNCTION TABLE

INPUTS( $\overline{OE}$ )	INPUTS(CLK)	INPUTS(D)	OUTPUT(Q)
L	↑	H	H
L	↑	L	L
L	H or L	X	Q0
H	X	X	Z

■ LOGIC SYMBOL

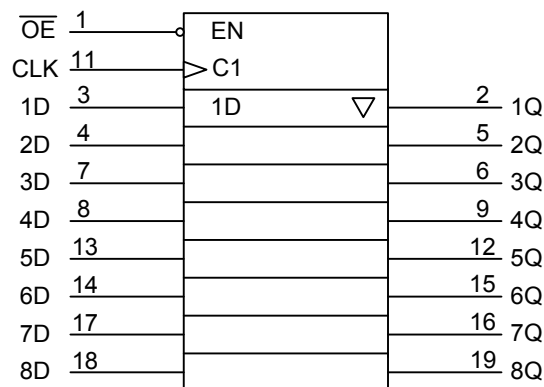

■ LOGIC DIAGRAM

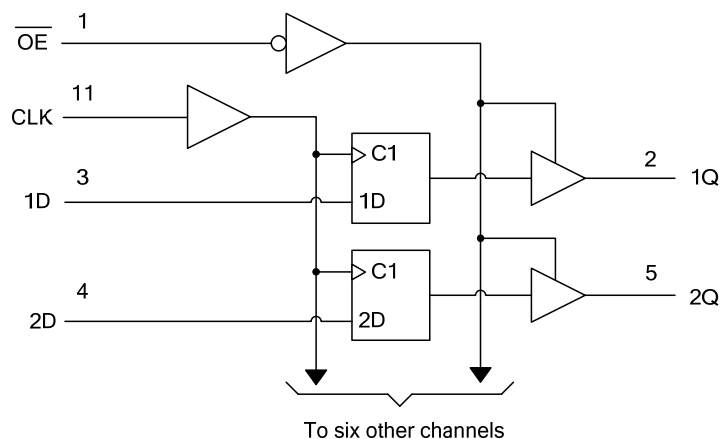

## ■ ABSOLUTE MAXIMUM RATING

PARAMETER	SYMBOL	RATINGS	UNIT
Supply Voltage	$V_{CC}$	-0.5 ~ 7	V
Input Voltage	$V_{IN}$	-0.5 ~ 7	V
Output Voltage	$V_{OUT}$	-0.5 ~ $V_{CC} + 0.5$	V
$V_{CC}$ or GND Current	$I_{CC}$	±75	mA
Output Current	$I_{OUT}$	±25	mA
Input Clamp Current	$I_{IK}$	-20	mA
Output Clamp Current	$I_{OK}$	±20	mA
Operating Temperature	$T_{OPR}$	-40 ~ + 85	°C
Storage Temperature	$T_{STG}$	-65 ~ + 150	°C

Note: Absolute maximum ratings are those values beyond which the device could be permanently damaged.  
 Absolute maximum ratings are stress ratings only and functional device operation is not implied.

## ■ RECOMMENDED OPERATING CONDITIONS

PARAMETER	SYMBOL	TEST CONDITIONS	MIN	TYP	MAX	UNIT
Supply Voltage	$V_{CC}$		2		5.5	V
High-level Input Voltage	$V_{IH}$	$V_{CC}=2V$	1.5			V
		$V_{CC}=3V$	2.1			
		$V_{CC}=5.5V$	3.85			
Low-level Input Voltage	$V_{IL}$	$V_{CC}=2V$			0.5	V
		$V_{CC}=3V$			0.9	
		$V_{CC}=5.5V$			1.65	
Input Voltage	$V_{IN}$		0		$V_{CC}$	V
Output Voltage	$V_{OUT}$	High or low state	0		$V_{CC}$	V
High-level Output Current	$I_{OH}$	$V_{CC} = 2 V$			-50	μA
		$V_{CC} = 3.3 V \pm 0.3 V$			-4	mA
		$V_{CC} = 5 V \pm 0.5 V$			-8	
Low-level Output Current	$I_{OL}$	$V_{CC} = 2 V$			50	μA
		$V_{CC} = 3.3 V \pm 0.3 V$			4	mA
		$V_{CC} = 5 V \pm 0.5 V$			8	
Input Rise or Fall Times	$t_R, t_F$	$V_{CC} = 3.3 V \pm 0.3 V$			100	ns
		$V_{CC} = 5 V \pm 0.5 V$			20	

## ■ ELECTRICAL CHARACTERISTICS ( $T_A=25^\circ C$ )

PARAMETER	SYMBOL	TEST CONDITIONS	MIN	TYP	MAX	UNIT
Output Voltage High-Level	$V_{OH}$	$V_{CC}=2V, I_{OH}=-50\mu A$	1.9	2		V
		$V_{CC}=3V, I_{OH}=-50\mu A$	2.9	3		
		$V_{CC}=4.5V, I_{OH}=-50\mu A$	4.4	4.5		
		$V_{CC}=3V, I_{OH}=-4mA$	2.58			
		$V_{CC}=4.5V, I_{OH}=-8mA$	3.94			
Output Voltage Low-Level	$V_{OL}$	$V_{CC}=2V, I_{OH}=50\mu A$			0.1	V
		$V_{CC}=3V, I_{OH}=50\mu A$			0.1	
		$V_{CC}=4.5V, I_{OH}=50\mu A$			0.1	
		$V_{CC}=3V, I_{OH}=4mA$			0.36	
		$V_{CC}=4.5V, I_{OH}=8mA$			0.36	
Input Leakage Current	$I_{I(LEAK)}$	$V_{CC} = 0$ to 5.5V, $V_{IN}=5.5V$ or GND			±0.1	μA
3-state Leakage Current	$I_{OZ}$	$V_{CC}=5.5V, V_{OUT}=V_{CC}$ or GND			±0.25	μA
Quiescent Supply Current	$I_{CC}$	$V_{CC}=5.5V, V_{IN}=V_{CC}$ or GND, $I_{OUT}=0$			4	μA
Input Capacitance	$C_I$	$V_{CC}=5V, V_{IN}=V_{CC}$ or GND		4	10	pF
Output Capacitance	$C_O$	$V_{CC}=5V, V_{OUT}=V_{CC}$ or GND		6		pF

■ SWITCHING CHARACTERISTICS (See TEST CIRCUIT AND WAVEFORMS)

PARAMETER	SYMBOL	TEST CONDITIONS	MIN	TYP	MAX	UNIT	
From CLK to Q	$t_{PLH}/t_{PHL}$	$V_{CC} = 3.3V \pm 0.3V$	$C_L = 15pF$		8.1	12.7	ns
			$C_L = 50pF$		10.6	16.2	
		$V_{CC} = 5V \pm 0.5V$	$C_L = 15pF$		5.4	8.1	
			$C_L = 50pF$		6.9	10.1	
From $\overline{OE}$ to Q	$t_{PZL}/t_{PZH}$	$V_{CC} = 3.3V \pm 0.3V$	$C_L = 15pF$		7.1	11	ns
			$C_L = 50pF$		9.6	14.5	
		$V_{CC} = 5V \pm 0.5V$	$C_L = 15pF$		5.1	7.6	
			$C_L = 50pF$		6.6	9.6	
From $\overline{OE}$ to Q	$t_{PLZ}/t_{PHZ}$	$V_{CC} = 3.3V \pm 0.3V$	$C_L = 15pF$		7.5	10.5	ns
			$C_L = 50pF$		10.2	14	
		$V_{CC} = 5V \pm 0.5V$	$C_L = 15pF$		4.6	6.8	
			$C_L = 50pF$		6.1	8.8	
Maximum Clock Frequency	$f_{MAX}$	$V_{CC} = 3.3V \pm 0.3V$	$C_L = 15pF$	80	130		MHz
			$C_L = 50pF$	55	85		
		$V_{CC} = 5V \pm 0.5V$	$C_L = 15pF$	130	185		
			$C_L = 50pF$	85	120		
Pulse Width	$t_W$	$V_{CC} = 3.3V \pm 0.3V$		5		ns	
		$V_{CC} = 5V \pm 0.5V$		5			
Setup Time	$t_{SU}$	$V_{CC} = 3.3V \pm 0.3V$		4.5		ns	
		$V_{CC} = 5V \pm 0.5V$		3			
Hold Time	$t_H$	$V_{CC} = 3.3V \pm 0.3V$		2		ns	
		$V_{CC} = 5V \pm 0.5V$		2			

■ OPERATING CHARACTERISTICS ( $T_A=25^\circ C$ )

PARAMETER	SYMBOL	TEST CONDITIONS	RATINGS	UNIT
Power Dissipation Capacitance	$C_{PD}$	No load, $V_{CC} = 5V$ , $f=1MHz$	32	pF

## TEST CIRCUIT AND WAVEFORMS

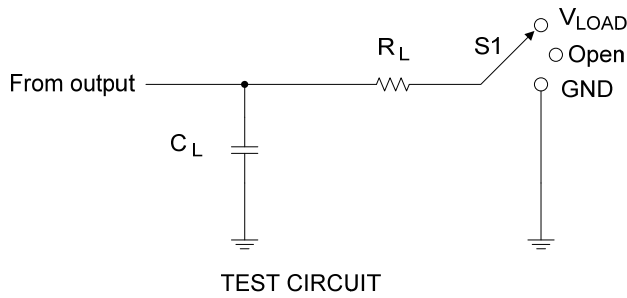

TEST	S1
$t_{PLH}/t_{PHL}$	Open
$t_{PLZ}/t_{PZL}$	$V_{LOAD}$
$t_{PHZ}/t_{PZH}$	GND

$V_{CC}$	Input		$V_M$	$V_{LOAD}$	$C_L$	$R_L$	$V_{\Delta}$
	$V_{IN}$	$t_R, t_F$					
$3.3V \pm 0.3V$	$V_{CC}$	$\leq 3ns$	$V_{CC}/2$	$V_{CC}$	15pF	1k $\Omega$	0.3V
					50pF		
$5V \pm 0.5V$	$V_{CC}$	$\leq 3ns$	$V_{CC}/2$	$V_{CC}$	15pF	1k $\Omega$	0.5V
					50pF		

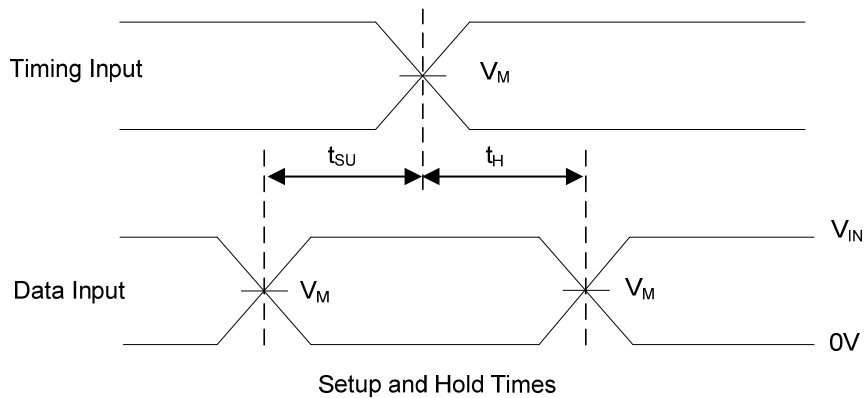
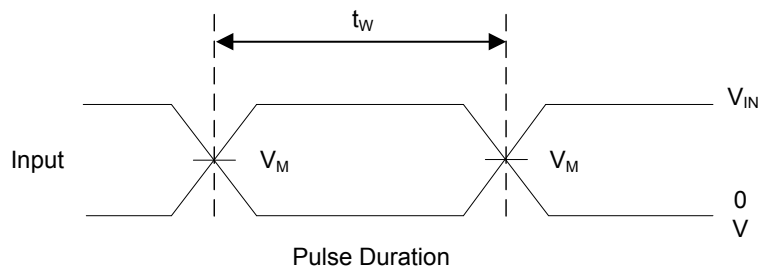

■ TEST CIRCUIT AND WAVEFORMS(Cont.)

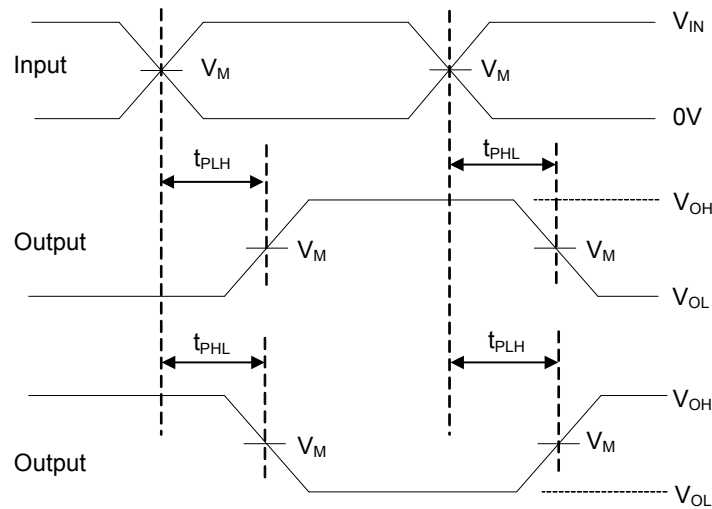

Voltage Waveforms Propagation Delay Times

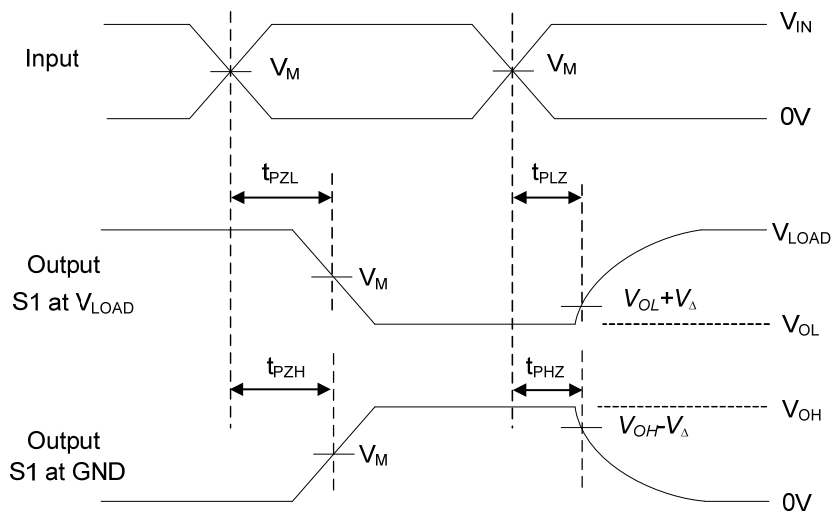

Voltage Waveforms Enable and Disable Times

Note: A.  $C_L$  includes probe and jig capacitance.

B.  $P_{RR} \leq 1MHz$ ,  $Z_O = 50\Omega$ ,  $t_R \leq 3ns$ ,  $t_F \leq 3ns$ .

UTC assumes no responsibility for equipment failures that result from using products at values that exceed, even momentarily, rated values (such as maximum ratings, operating condition ranges, or other parameters) listed in products specifications of any and all UTC products described or contained herein. UTC products are not designed for use in life support appliances, devices or systems where malfunction of these products can be reasonably expected to result in personal injury. Reproduction in whole or in part is prohibited without the prior written consent of the copyright owner. The information presented in this document does not form part of any quotation or contract, is believed to be accurate and reliable and may be changed without notice.