



U74AUP1G126

CMOS IC

SINGLE BUS BUFFER GATE WITH 3-STATE OUTPUT

■ DESCRIPTION

The **U74AUP1G126** is single bus buffer gate with 3-state output. The output is disabled When the output enable (OE) is low. When OE is high, true data is passed from A input to the Y output.

This device ensures a very low static and dynamic power consumption across the entire V_{CC} range from 0.8V to 3.6V.

This device has power-down protective circuit, preventing device destruction when it is powered down.

■ FEATURES

- * Wide supply voltage range from 0.8V to 3.6V
- * Inputs accept voltages up to 3.6V
- * I_{OFF} supports partial-power-down mode
- * Low static power consumption; $I_{CC}=0.5\mu A$ (Max.)
- * Optimized for 3.3V Operation

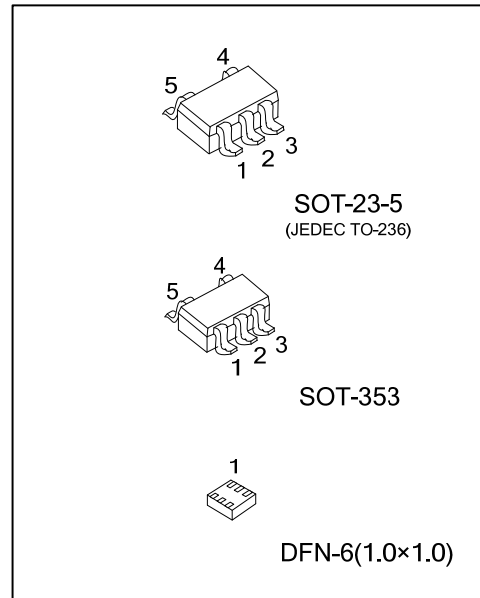

■ ORDERING INFORMATION

Ordering Number	Package	Packing
U74AUP1G126G-AE5-R	SOT-23-5	Tape Reel
U74AUP1G126G-AL5-R	SOT-353	Tape Reel
U74AUP1G126G-K06-1010-R	DFN-6(1.0x1.0)	Tape Reel

<p>U74AUP1G126G-AE5-R</p> <p>(1)Packing Type (2)Package Type (3)Green Package</p>	<p>(1) R: Tape Reel (2) AE5: SOT-23-5, AL5: SOT-353, K06-1010: DFN-6(1.0x1.0) (3) G: Halogen Free and Lead Free</p>
---	---

■ MARKING

SOT-23-5 / SOT-353	DFN-6(1.0x1.0)

■ PIN CONFIGURATION

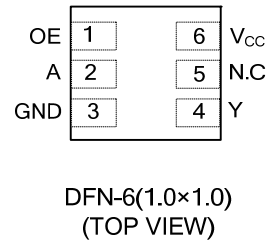
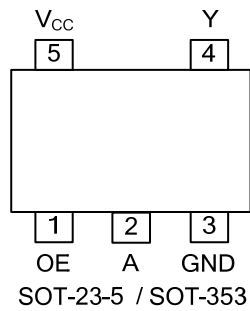

■ FUNCTION TABLE

INPUT(OE)	INPUT(A)	OUTPUT(Y)
H	H	H
H	L	L
L	X	Z

Note: H: HIGH voltage level; L: LOW voltage level; X: don't care; Z: high impedance state

■ LOGIC DIAGRAM (positive logic)

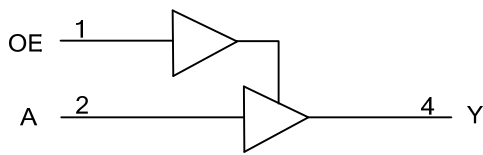

Logic symbol

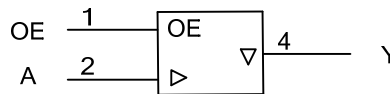

IEC logic symbol

■ ABSOLUTE MAXIMUM RATING

PARAMETER	SYMBOL	CONDITIONS	RATINGS	UNIT
Supply Voltage	V_{CC}		-0.5 ~ +4.6	V
Input Voltage	V_{IN}		-0.5 ~ +4.6	V
Output Voltage	V_{OUT}	Output in the high or low state	-0.5 ~ $V_{CC} + 0.5$	V
		Output in the power-off state	-0.5 ~ +4.6	V
Continuous V_{CC} or GND Current	I_{CC}		±50	mA
Continuous Output Current	I_{OUT}	$V_{OUT}=0 \sim V_{CC}$	±20	mA
Input Clamp Current	I_{IK}	$V_{IN} < 0$	-50	mA
Output Clamp Current	I_{OK}	$V_O > V_{CC}$ or $V_{OUT} < 0$	-50	mA
Storage Temperature Range	T_{STG}		-65 ~ +150	°C

Note: Absolute maximum ratings are those values beyond which the device could be permanently damaged. Absolute maximum ratings are stress ratings only and functional device operation is not implied.

■ RECOMMENDED OPERATING CONDITIONS

PARAMETER	SYMBOL	TEST CONDITIONS	MIN	TYP	MAX	UNIT
Supply Voltage	V_{CC}	Operating	0.8		3.6	V
Input Voltage	V_{IN}		0		3.6	V
Output Voltage	V_{OUT}	High or low state	0		V_{CC}	V
Operating Temperature	T_A		-40		85	°C
Input Transition Rise or Fall Rate	$\Delta t/\Delta v$	$V_{CC}=0.8V \sim 3.6V$			200	ns/V

■ ELECTRICAL CHARACTERISTICS ($T_A = 25^\circ\text{C}$, unless otherwise specified)

PARAMETER	SYMBOL	TEST CONDITIONS	MIN	TYP	MAX	UNIT	
High-level Input Voltage	V_{IH}	$V_{CC}=0.8V$	V_{CC}		3.6	V	
		$V_{CC}=1.1V \sim 1.95V$	$0.65 \times V_{CC}$		3.6	V	
		$V_{CC}=2.3V \sim 2.7V$	1.6		3.6	V	
		$V_{CC}=3V \sim 3.6V$	2		3.6	V	
Low-level Input Voltage	V_{IL}	$V_{CC}=0.8V$			0	V	
		$V_{CC}=1.1V \sim 1.95V$	0		$0.35 \times V_{CC}$	V	
		$V_{CC}=2.3V \sim 2.7V$	0		0.7	V	
		$V_{CC}=3V \sim 3.6V$	0		0.9	V	
High-Level Output Voltage	V_{OH}	$V_{CC}=0.8 \sim 3.6V, I_{OH}=-20\mu A$	$V_{CC}-0.1$			V	
		$V_{CC}=1.1V, I_{OH}=-1.1mA$	$0.75 \times V_{CC}$			V	
		$V_{CC}=1.4V, I_{OH}=-1.7mA$	1.11			V	
		$V_{CC}=1.65V, I_{OH}=-1.9mA$	1.32			V	
		$V_{CC}=2.3V$	$I_{OH}=-2.3mA$	2.05			V
			$I_{OH}=-3.1mA$	1.9			V
		$V_{CC}=3V$	$I_{OH}=-2.7mA$	2.72			V
			$I_{OH}=-4mA$	2.6			V
Low-Level Output Voltage	V_{OL}	$V_{CC}=0.8 \sim 3.6V, I_{OH}=-20\mu A$			0.1	V	
		$V_{CC}=1.1V, I_{OH}=-1.1mA$			$0.3 \times V_{CC}$	V	
		$V_{CC}=1.4V, I_{OH}=-1.7mA$			0.31	V	
		$V_{CC}=1.65V, I_{OH}=-1.9mA$			0.31	V	
		$V_{CC}=2.3V$	$I_{OH}=2.3mA$			0.31	V
			$I_{OH}=3.1mA$			0.44	V
		$V_{CC}=3V$	$I_{OH}=2.7mA$			0.31	V
			$I_{OH}=4mA$			0.44	V

■ ELECTRICAL CHARACTERISTICS (Cont.)

PARAMETER	SYMBOL	TEST CONDITIONS	MIN	TYP	MAX	UNIT
Input Leakage Current	$I_{I(LEAK)}$	$V_{CC}=0 \sim 3.6V, V_{IN}=GND \sim 3.6V$			± 0.1	μA
Power OFF Leakage Current	I_{off}	$V_{CC}=0 V, V_{IN}$ or $V_{OUT}=0 \sim 3.6V$			± 0.2	μA
Additional Power OFF Leakage Current	ΔI_{off}	$V_{CC}=0 V \sim 0.2V,$ V_{IN} or $V_{OUT}=0 \sim 3.6V$			± 0.2	μA
Quiescent Supply Current	I_{CC}	$V_{CC}=0.8 \sim 3.6V, V_{IN}=V_{CC}$ or $GND,$ $I_{OUT}=0$			0.5	μA
Additional Quiescent Supply Current Per Input Pin	ΔI_{CC}	$V_{CC}=3.3 V, V_{IN}=V_{CC}-0.6V, I_{OUT}=0$			40	μA
Input Capacitance	C_I	$V_{CC}=0V, V_{IN}=V_{CC}$ or GND		1.5		pF
		$V_{CC}=3.6V, V_{IN}=V_{CC}$ or GND		1.5		pF
Output Capacitance	C_{OUT}	$V_{CC}=0V, V_{OUT}=GND$		3		pF

■ SWITCHING CHARACTERISTICS ($T_A = 25^\circ C$, unless otherwise specified)

PARAMETER	SYMBOL	TEST CONDITIONS	MIN	TYP	MAX	UNIT	
Propagation delay from input(A) to output(Y)	t_{PD}	$C_L=5pF,$ $R_L=5K\Omega$	$V_{CC}=0.8V$		18.1		ns
			$V_{CC}=1.2\pm 0.1V$	4.3	7.4		ns
			$V_{CC}=1.5\pm 0.1V$	3.3	5.2		ns
			$V_{CC}=1.8\pm 0.15V$	2.6	4.1		ns
			$V_{CC}=2.5\pm 0.2V$	2	2.9		ns
		$C_L=10pF,$ $R_L=5K\Omega$	$V_{CC}=3.3\pm 0.3V$	1.7	2.4		ns
			$V_{CC}=0.8V$		20.5		ns
			$V_{CC}=1.2\pm 0.1V$	4.6	8.4		ns
			$V_{CC}=1.5\pm 0.1V$	3.5	5.9		ns
			$V_{CC}=1.8\pm 0.15V$	3.9	4.7		ns
		$C_L=15pF,$ $R_L=5K\Omega$	$V_{CC}=2.5\pm 0.2V$	2.3	3.4		ns
			$V_{CC}=3.3\pm 0.3V$	2.1	2.8		ns
			$V_{CC}=0.8V$		22.5		ns
			$V_{CC}=1.2\pm 0.1V$	5.8	9.3		ns
			$V_{CC}=1.5\pm 0.1V$	4.4	6.6		ns
		$C_L=30pF,$ $R_L=5K\Omega$	$V_{CC}=1.8\pm 0.15V$	3.5	5.3		ns
			$V_{CC}=2.5\pm 0.2V$	2.7	3.9		ns
			$V_{CC}=3.3\pm 0.3V$	2.4	3.2		ns
			$V_{CC}=0.8V$		29		ns
			$V_{CC}=1.2\pm 0.1V$	7.4	12		ns
$C_L=30pF,$ $R_L=5K\Omega$	$V_{CC}=1.5\pm 0.1V$	5.7	8.6		ns		
	$V_{CC}=1.8\pm 0.15V$	4.8	6.9		ns		
	$V_{CC}=2.5\pm 0.2V$	3.9	5.1		ns		
		$V_{CC}=3.3\pm 0.3V$	3.5	4.8		ns	

■ SWITCHING CHARACTERISTICS (Cont.)

PARAMETER	SYMBOL	TEST CONDITIONS	MIN	TYP	MAX	UNIT		
Propagation delay from input(OE) to output(Y)	t_{en}	$C_L=5pF,$ $R_L=5K\Omega$	$V_{CC}=0.8V$		19.1		ns	
			$V_{CC}=1.2\pm 0.1V$	5.1	9.3		ns	
			$V_{CC}=1.5\pm 0.1V$	4.1	6.6		ns	
			$V_{CC}=1.8\pm 0.15V$	3.2	5.3		ns	
			$V_{CC}=2.5\pm 0.2V$	2.5	3.8		ns	
			$V_{CC}=3.3\pm 0.3V$	2.1	3.2		ns	
		$C_L=10pF,$ $R_L=5K\Omega$	$V_{CC}=0.8V$			21.8		ns
			$V_{CC}=1.2\pm 0.1V$	4.9	10.2		ns	
			$V_{CC}=1.5\pm 0.1V$	3.9	7.3		ns	
			$V_{CC}=1.8\pm 0.15V$	3.4	5.8		ns	
			$V_{CC}=2.5\pm 0.2V$	2.5	4.3		ns	
			$V_{CC}=3.3\pm 0.3V$	2.1	3.7		ns	
		$C_L=15pF,$ $R_L=5K\Omega$	$V_{CC}=0.8V$			25.2		ns
			$V_{CC}=1.2\pm 0.1V$	7	11.3		ns	
			$V_{CC}=1.5\pm 0.1V$	5.5	8.1		ns	
			$V_{CC}=1.8\pm 0.15V$	4.3	6.5		ns	
			$V_{CC}=2.5\pm 0.2V$	3.4	4.8		ns	
			$V_{CC}=3.3\pm 0.3V$	2.9	4.1		ns	
		$C_L=30pF,$ $R_L=5K\Omega$	$V_{CC}=0.8V$			33.4		ns
			$V_{CC}=1.2\pm 0.1V$	8.8	14.1		ns	
			$V_{CC}=1.5\pm 0.1V$	6.9	10.1		ns	
			$V_{CC}=1.8\pm 0.15V$	5.6	8.1		ns	
			$V_{CC}=2.5\pm 0.2V$	4.3	6.1		ns	
			$V_{CC}=3.3\pm 0.3V$	3.7	5.2		ns	
Propagation delay from input(OE) to output(Y)	t_{dis}	$C_L=5pF,$ $R_L=5K\Omega$	$V_{CC}=0.8V$		12.1		ns	
			$V_{CC}=1.2\pm 0.1V$	2.4	4.1		ns	
			$V_{CC}=1.5\pm 0.1V$	1.8	2.9		ns	
			$V_{CC}=1.8\pm 0.15V$	1	2.9		ns	
			$V_{CC}=2.5\pm 0.2V$	1	1.8		ns	
			$V_{CC}=3.3\pm 0.3V$	1.2	2.2		ns	
		$C_L=10pF,$ $R_L=5K\Omega$	$V_{CC}=0.8V$			13		ns
			$V_{CC}=1.2\pm 0.1V$	3.8	6.6		ns	
			$V_{CC}=1.5\pm 0.1V$	2.2	4.7		ns	
			$V_{CC}=1.8\pm 0.15V$	2.4	4.4		ns	
			$V_{CC}=2.5\pm 0.2V$	1.3	3.1		ns	
			$V_{CC}=3.3\pm 0.3V$	1.9	3.4		ns	
		$C_L=15pF,$ $R_L=5K\Omega$	$V_{CC}=0.8V$			14		ns
			$V_{CC}=1.2\pm 0.1V$	3.7	5.8		ns	
			$V_{CC}=1.5\pm 0.1V$	5.5	3.9		ns	
			$V_{CC}=1.8\pm 0.15V$	3.3	4.5		ns	
			$V_{CC}=2.5\pm 0.2V$	2.3	3.2		ns	
			$V_{CC}=3.3\pm 0.3V$	2.4	4.8		ns	
		$C_L=30pF,$ $R_L=5K\Omega$	$V_{CC}=0.8V$			17.7		ns
			$V_{CC}=1.2\pm 0.1V$	5.8	10		ns	
			$V_{CC}=1.5\pm 0.1V$	5.7	7.7		ns	
			$V_{CC}=1.8\pm 0.15V$	4.5	7.7		ns	
			$V_{CC}=2.5\pm 0.2V$	3.9	5.6		ns	
			$V_{CC}=3.3\pm 0.3V$	3.3	8.4		ns	

■ OPERATING CHARACTERISTICS ($T_A = 25^\circ\text{C}$, unless otherwise specified)

PARAMETER	SYMBOL	TEST CONDITIONS	MIN	TYP	MAX	UNIT
Power Dissipation Capacitance (Outputs enabled)	C_{PD}	$V_{CC}=0.8\text{V}$, $f=10\text{MHz}$		3.8		pF
		$V_{CC}=1.2\pm 0.1\text{V}$, $f=10\text{MHz}$		3.7		pF
		$V_{CC}=1.5\pm 0.1\text{V}$, $f=10\text{MHz}$		3.7		pF
		$V_{CC}=1.8\pm 0.15\text{V}$, $f=10\text{MHz}$		3.7		pF
		$V_{CC}=2.5\pm 0.2\text{V}$, $f=10\text{MHz}$		3.9		pF
		$V_{CC}=3.3\pm 0.3\text{V}$, $f=10\text{MHz}$		4		pF

■ TEST CIRCUIT AND WAVEFORMS

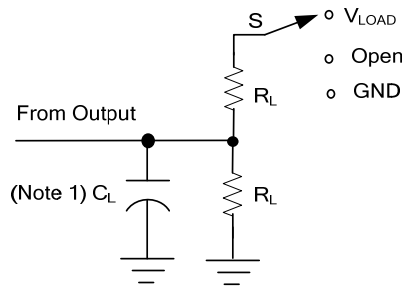

TEST	S
t_{PLH}/t_{PHL}	Open
t_{PHZ}/t_{PZH}	GND
t_{PLZ}/t_{PZL}	$2 \times V_{CC}$

TEST CIRCUIT

V_{CC}	V_{IN}	t_R / t_F	V_M	V_{LOAD}	C_L	R_L	V_{Δ}
0.8	V_{CC}	3ns	$V_{CC}/2$	$2 \times V_{CC}$	5,10,15,30pF	5k Ω	0.1V
$1.2 \pm 0.1V$	V_{CC}	3ns	$V_{CC}/2$	$2 \times V_{CC}$	5,10,15,30pF	5k Ω	0.1V
$1.5 \pm 0.1V$	V_{CC}	3ns	$V_{CC}/2$	$2 \times V_{CC}$	5,10,15,30pF	5k Ω	0.1V
$1.8 \pm 0.15V$	V_{CC}	3ns	$V_{CC}/2$	$2 \times V_{CC}$	5,10,15,30pF	5k Ω	0.15V
$2.5 \pm 0.2V$	V_{CC}	3ns	$V_{CC}/2$	$2 \times V_{CC}$	5,10,15,30pF	5k Ω	0.15V
$3.3 \pm 0.3V$	V_{CC}	3ns	$V_{CC}/2$	$2 \times V_{CC}$	5,10,15,30pF	5k Ω	0.3V

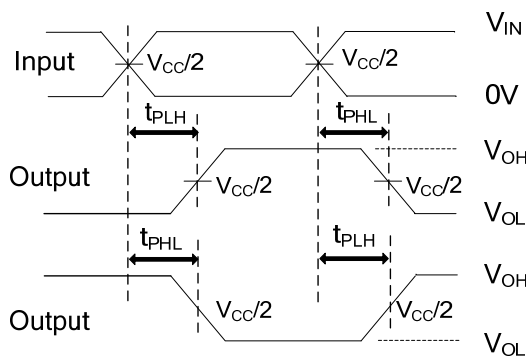

PROPAGATION DELAY TIMES

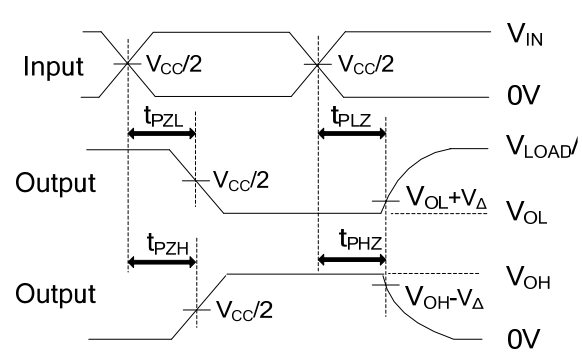

ENABLE AND DISABLE TIMES

Notes: 1. C_L includes probe and jig capacitance.

2. All input pulses are supplied by generators having the following characteristics: PRR $\leq 10MHz$, $Z_0 = 50\Omega$.

UTC assumes no responsibility for equipment failures that result from using products at values that exceed, even momentarily, rated values (such as maximum ratings, operating condition ranges, or other parameters) listed in products specifications of any and all UTC products described or contained herein. UTC products are not designed for use in life support appliances, devices or systems where malfunction of these products can be reasonably expected to result in personal injury. Reproduction in whole or in part is prohibited without the prior written consent of the copyright owner. The information presented in this document does not form part of any quotation or contract, is believed to be accurate and reliable and may be changed without notice.