



## U74AUP1G32

CMOS IC

### SINGLE 2-INPUT OR GATE

#### DESCRIPTION

The **U74AUP1G32** is a single 2-input OR gate which provides the Function  $Y=A+B$  or  $Y=\overline{\overline{A} + \overline{B}}$  in positive logic.

This device ensures a very low static and dynamic power consumption across the entire  $V_{CC}$  range from 0.8V to 3.6V.

This device has power-down protective circuit, preventing device destruction when it is powered down.

#### FEATURES

- \* Wide supply voltage range from 0.8V to 3.6V
- \* Inputs accept voltages up to 3.6V
- \*  $I_{OFF}$  supports partial-power-down mode
- \* Low static power consumption;  $I_{CC}=0.5\mu A$  (Max.)
- \* Optimized for 3.3V Operation

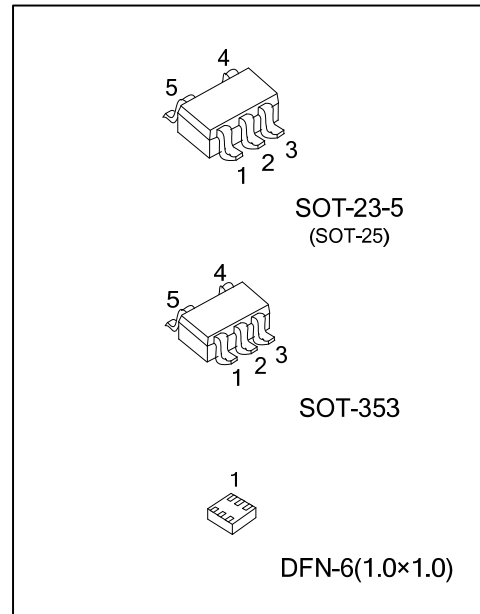

#### ORDERING INFORMATION

Ordering Number	Package	Packing
U74AUP1G32G-AE5-R	SOT-23-5	Tape Reel
U74AUP1G32G-AL5-R	SOT-353	Tape Reel
U74AUP1G32G-K06-1010-R	DFN-6(1.0x1.0)	Tape Reel

<p>U74AUP1G32G-AE5-R</p> <p>(1) Packing Type (2) Package Type (3) Green Package</p>	<p>(1) R: Tape Reel (2) AE5: SOT-23-5, AL5: SOT-353, K06-1010: DFN-6(1.0x1.0) (3) G: Halogen Free and Lead Free</p>
---------------------------------------------------------------------------------------------	---------------------------------------------------------------------------------------------------------------------------------

#### MARKING

SOT-23-5 / SOT-353	DFN-6(1.0x1.0)
<p>P32</p>	<p>PH</p>

■ PIN CONFIGURATION

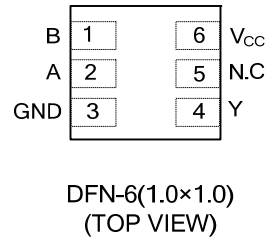
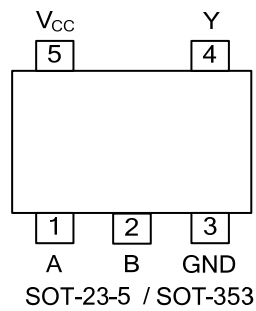

■ FUNCTION TABLE

INPUT(A)	INPUT(B)	OUTPUT(Y)
H	X	H
X	H	H
L	L	L

Note: H: HIGH voltage level; L: LOW voltage level; X: don't care.

■ LOGIC DIAGRAM (positive logic)

For SOT-23-5/SOT-353

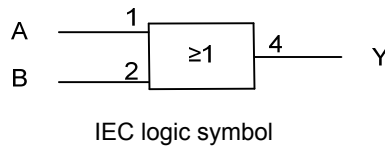
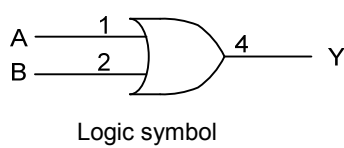

For DFN-6(1.0x1.0)

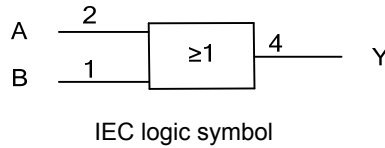
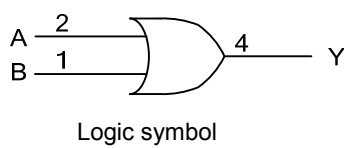

### ■ ABSOLUTE MAXIMUM RATING

PARAMETER	SYMBOL	CONDITIONS	RATINGS	UNIT
Supply Voltage	$V_{CC}$		-0.5 ~ +4.6	V
Input Voltage	$V_{IN}$		-0.5 ~ +4.6	V
Output Voltage	$V_{OUT}$	Output in the high or low state	-0.5 ~ $V_{CC} + 0.5$	V
		Output in the power-off state	-0.5 ~ +4.6	V
Continuous $V_{CC}$ or GND Current	$I_{CC}$		±50	mA
Continuous Output Current	$I_{OUT}$	$V_{OUT}=0 \sim V_{CC}$	±20	mA
Input Clamp Current	$I_{IK}$	$V_{IN} < 0$	-50	mA
Output Clamp Current	$I_{OK}$	$V_O > V_{CC}$ or $V_{OUT} < 0$	-50	mA
Storage Temperature Range	$T_{STG}$		-65 ~ +150	°C

Note: Absolute maximum ratings are those values beyond which the device could be permanently damaged. Absolute maximum ratings are stress ratings only and functional device operation is not implied.

### ■ RECOMMENDED OPERATING CONDITIONS

PARAMETER	SYMBOL	TEST CONDITIONS	MIN	TYP	MAX	UNIT
Supply Voltage	$V_{CC}$	Operating	0.8		3.6	V
Input Voltage	$V_{IN}$		0		3.6	V
Output Voltage	$V_{OUT}$	High or low state	0		$V_{CC}$	V
Operating Temperature	$T_A$		-40		85	°C
Input Transition Rise or Fall Rate	$\Delta t/\Delta v$	$V_{CC}=0.8V \sim 3.6V$			200	ns/V

### ■ ELECTRICAL CHARACTERISTICS ( $T_A = 25^\circ\text{C}$ , unless otherwise specified)

PARAMETER	SYMBOL	TEST CONDITIONS	MIN	TYP	MAX	UNIT	
High-level Input Voltage	$V_{IH}$	$V_{CC}=0.8V$	$V_{CC}$			V	
		$V_{CC}=1.1V \sim 1.95V$	$0.65 \times V_{CC}$			V	
		$V_{CC}=2.3V \sim 2.7V$	1.6			V	
		$V_{CC}=3V \sim 3.6V$	2			V	
Low-level Input Voltage	$V_{IL}$	$V_{CC}=0.8V$			0	V	
		$V_{CC}=1.1V \sim 1.95V$			$0.35 \times V_{CC}$	V	
		$V_{CC}=2.3V \sim 2.7V$			0.7	V	
		$V_{CC}=3V \sim 3.6V$			0.9	V	
High-Level Output Voltage	$V_{OH}$	$V_{CC}=0.8 \sim 3.6V, I_{OH}=-20\mu A$	$V_{CC}-0.1$			V	
		$V_{CC}=1.1V, I_{OH}=-1.1mA$	$0.75 \times V_{CC}$			V	
		$V_{CC}=1.4V, I_{OH}=-1.7mA$	1.11			V	
		$V_{CC}=1.65V, I_{OH}=-1.9mA$	1.32			V	
		$V_{CC}=2.3V$	$I_{OH}=-2.3mA$	2.05			V
			$I_{OH}=-3.1mA$	1.9			V
		$V_{CC}=3V$	$I_{OH}=-2.7mA$	2.72			V
			$I_{OH}=-4mA$	2.6			V
Low-Level Output Voltage	$V_{OL}$	$V_{CC}=0.8 \sim 3.6V, I_{OH}=-20\mu A$			0.1	V	
		$V_{CC}=1.1V, I_{OH}=-1.1mA$			$0.3 \times V_{CC}$	V	
		$V_{CC}=1.4V, I_{OH}=-1.7mA$			0.31	V	
		$V_{CC}=1.65V, I_{OH}=-1.9mA$			0.31	V	
		$V_{CC}=2.3V$	$I_{OH}=2.3mA$			0.31	V
			$I_{OH}=3.1mA$			0.44	V
		$V_{CC}=3V$	$I_{OH}=2.7mA$			0.31	V
			$I_{OH}=4mA$			0.44	V

### ■ ELECTRICAL CHARACTERISTICS (Cont.)

PARAMETER	SYMBOL	TEST CONDITIONS	MIN	TYP	MAX	UNIT
Input Leakage Current	$I_{I(LEAK)}$	$V_{CC}=0 \sim 3.6V, V_{IN}=GND \sim 3.6V$			$\pm 0.1$	$\mu A$
Power OFF Leakage Current	$I_{off}$	$V_{CC}=0 V, V_{IN}$ or $V_{OUT}=0 \sim 3.6V$			$\pm 0.2$	$\mu A$
Additional Power OFF Leakage Current	$\Delta I_{off}$	$V_{CC}=0 V \sim 0.2V, V_{IN}$ or $V_{OUT}=0 \sim 3.6V$			$\pm 0.2$	$\mu A$
Quiescent Supply Current	$I_{CC}$	$V_{CC}=0.8 \sim 3.6V, V_{IN}=V_{CC}$ or $GND, I_{OUT}=0$			0.5	$\mu A$
Additional Quiescent Supply Current Per Input Pin	$\Delta I_{CC}$	$V_{CC}=3.3 V, V_{IN}=V_{CC}-0.6V, I_{OUT}=0$			40	$\mu A$
Input Capacitance	$C_I$	$V_{CC}=0V, V_{IN}=V_{CC}$ or $GND$		1.5		pF
		$V_{CC}=3.6V, V_{IN}=V_{CC}$ or $GND$		1.5		pF
Output Capacitance	$C_{OUT}$	$V_{CC}=0V, V_{OUT}=GND$		3		pF

### ■ SWITCHING CHARACTERISTICS ( $T_A = 25^\circ C$ , unless otherwise specified)

PARAMETER	SYMBOL	TEST CONDITIONS	MIN	TYP	MAX	UNIT	
Propagation delay from inputs (A or B) to output(Y)	$t_{PD}$	$C_L=5pF, R_L=1M\Omega$	$V_{CC}=0.8V$		18		ns
			$V_{CC}=1.2\pm 0.1V$	2.6	7.3		ns
			$V_{CC}=1.5\pm 0.1V$	1.4	5.2		ns
			$V_{CC}=1.8\pm 0.15V$	1	4.2		ns
			$V_{CC}=2.5\pm 0.2V$	1	3		ns
		$C_L=10pF, R_L=1M\Omega$	$V_{CC}=3.3\pm 0.3V$	1	2.4		ns
			$V_{CC}=0.8V$		21		ns
			$V_{CC}=1.2\pm 0.1V$	1.5	8.5		ns
			$V_{CC}=1.5\pm 0.1V$	1	6.2		ns
			$V_{CC}=1.8\pm 0.15V$	1	5		ns
		$C_L=15pF, R_L=1M\Omega$	$V_{CC}=2.5\pm 0.2V$	1	3.6		ns
			$V_{CC}=3.3\pm 0.3V$	1	2.9		ns
			$V_{CC}=0.8V$		24		ns
			$V_{CC}=1.2\pm 0.1V$	3.6	9.9		ns
			$V_{CC}=1.5\pm 0.1V$	2.3	7.2		ns
		$C_L=30pF, R_L=1M\Omega$	$V_{CC}=1.8\pm 0.15V$	1.6	5.8		ns
			$V_{CC}=2.5\pm 0.2V$	1	4.3		ns
			$V_{CC}=3.3\pm 0.3V$	1	3.4		ns
			$V_{CC}=0.8V$		32.8		ns
			$V_{CC}=1.2\pm 0.1V$	4.9	13.1		ns
$C_L=30pF, R_L=1M\Omega$	$V_{CC}=1.5\pm 0.1V$	3.4	9.5		ns		
	$V_{CC}=1.8\pm 0.15V$	2.5	7.7		ns		
	$V_{CC}=2.5\pm 0.2V$	1.8	5.7		ns		
		$V_{CC}=3.3\pm 0.3V$	1.5	4.7		ns	

■ OPERATING CHARACTERISTICS (f=10 MHz, T<sub>A</sub> =25°C , unless otherwise specified)

PARAMETER	SYMBOL	TEST CONDITIONS	MIN	TYP	MAX	UNIT
Power Dissipation Capacitance	C <sub>PD</sub>	V <sub>CC</sub> =0.8V		4.1		pF
		V <sub>CC</sub> =1.2±0.1V		4.1		pF
		V <sub>CC</sub> =1.5±0.1V		4.1		pF
		V <sub>CC</sub> =1.8±0.15V		4.1		pF
		V <sub>CC</sub> =2.5±0.2V		4.2		pF
		V <sub>CC</sub> =3.3±0.3V		4.3		pF

■ TEST CIRCUIT AND WAVEFORMS

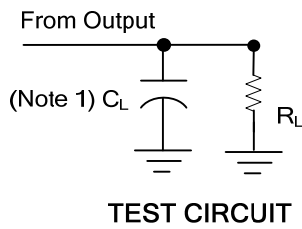

$V_{CC}$	$V_{IN}$	$t_R / t_F$	$V_M$	$C_L$	$R_L$
0.8V	$V_{CC}$	$\leq 3\text{ns}$	$V_{CC}/2$	5,10,15,30pF	1M $\Omega$
1.2V $\pm$ 0.1V	$V_{CC}$	$\leq 3\text{ns}$	$V_{CC}/2$	5,10,15,30pF	1M $\Omega$
1.5V $\pm$ 0.1V	$V_{CC}$	$\leq 3\text{ns}$	$V_{CC}/2$	5,10,15,30pF	1M $\Omega$
1.8V $\pm$ 0.15V	$V_{CC}$	$\leq 3\text{ns}$	$V_{CC}/2$	5,10,15,30pF	1M $\Omega$
2.5V $\pm$ 0.2V	$V_{CC}$	$\leq 3\text{ns}$	$V_{CC}/2$	5,10,15,30pF	1M $\Omega$
3.3V $\pm$ 0.3V	$V_{CC}$	$\leq 3\text{ns}$	$V_{CC}/2$	5,10,15,30pF	1M $\Omega$

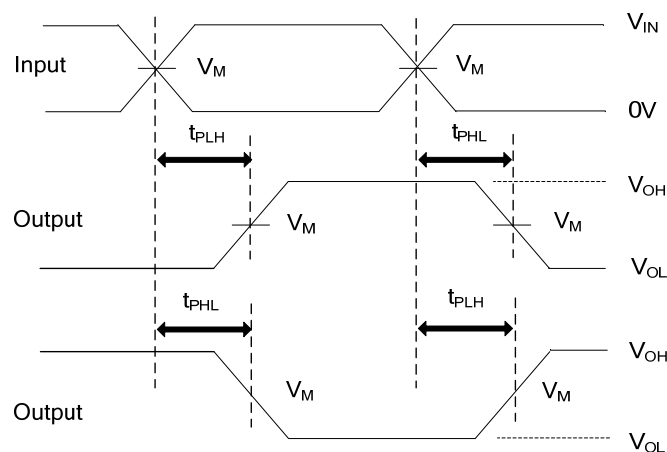

Notes: 1.  $C_L$  includes probe and jig capacitance.

2. All input pulses are supplied by generators having the following characteristics: PRR  $\leq$  10MHz,  $Z_O = 50\Omega$ .

UTC assumes no responsibility for equipment failures that result from using products at values that exceed, even momentarily, rated values (such as maximum ratings, operating condition ranges, or other parameters) listed in products specifications of any and all UTC products described or contained herein. UTC products are not designed for use in life support appliances, devices or systems where malfunction of these products can be reasonably expected to result in personal injury. Reproduction in whole or in part is prohibited without the prior written consent of the copyright owner. The information presented in this document does not form part of any quotation or contract, is believed to be accurate and reliable and may be changed without notice.