



## U74CBT3126

CMOS IC

### QUADRUPLE FET BUS SWITCH

#### DESCRIPTION

The **U74CBT3126** is a quadruple line bus switch. It is composed of four 1-bit line switches with independent separate output-enable (OE) inputs. When OE is low, the switch is disabled.

To ensure the high-impedance state during power up or power down, OE should be tied to GND through a pull-down resistor and the minimum value of the resistor is determined by the current-sourcing capability of the driver.

#### FEATURES

- \* 5  $\Omega$  switch connection between two ports
- \* Max  $t_{pd}$  of 0.25 ns at 5V
- \* Low power consumption,  $I_{CC} = 3 \mu A$  (Max.) at 5.5V
- \* TTL compatible input levels

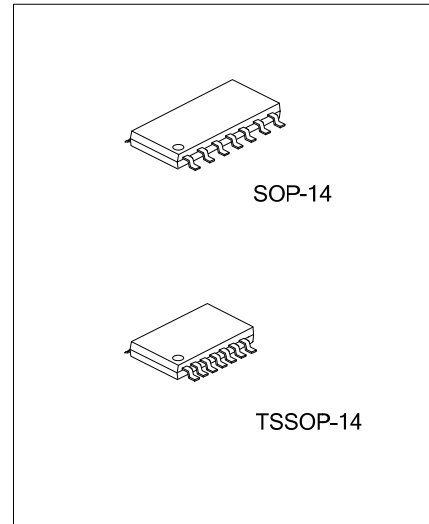

#### ORDERING INFORMATION

Ordering Number	Package	Packing
U74CBT3126G-S14-R	SOP-14	Tape Reel
U74CBT3126G-P14-R	TSSOP-14	Tape Reel

<p>U74CBT3126G-S14-R</p> <ul style="list-style-type: none"> <li>(1) Packing Type</li> <li>(2) Package Type</li> <li>(3) Green Package</li> </ul>	<ul style="list-style-type: none"> <li>(1) R: Tape Reel</li> <li>(2) S14: SOP-14, P14: TSSOP-14</li> <li>(3) G: Halogen Free and Lead Free</li> </ul>
--	---

#### MARKING

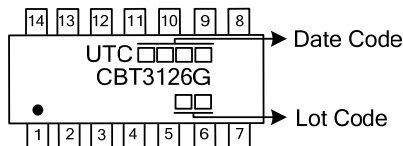

■ PIN CONFIGURATION

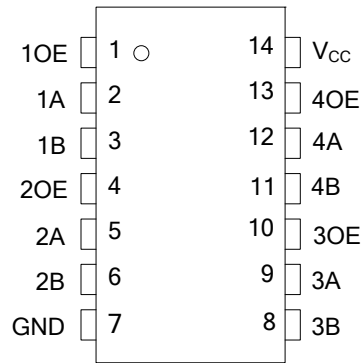

■ FUNCTION TABLE (each bus switch)

INPUT OE	FUNCTION
L	Z
H	A=B

■ LOGIC DIAGRAM (positive logic)

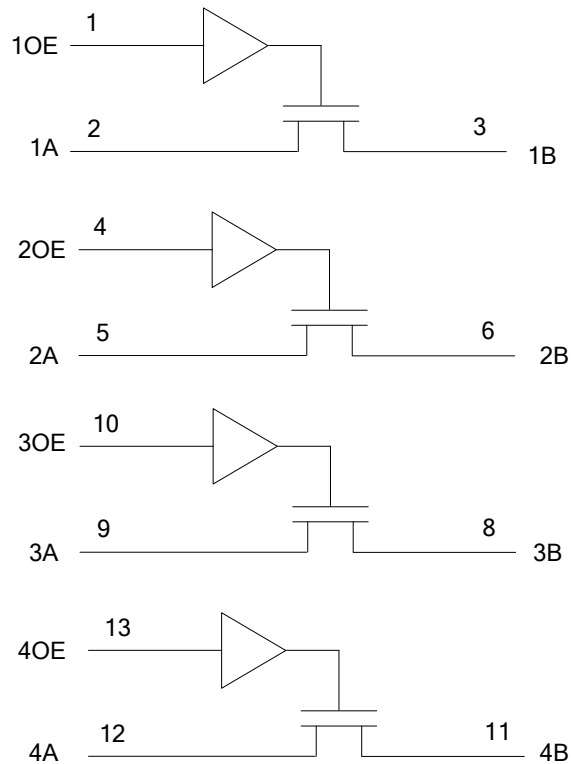

■ ABSOLUTE MAXIMUM RATING ( $T_A = 25^\circ\text{C}$ , unless otherwise specified)

PARAMETER		SYMBOL	RATINGS	UNIT
Supply Voltage		$V_{CC}$	-0.5~7	V
Input Voltage		$V_{IN}$	-0.5~7	V
Supply Voltage		$V_{CC}$	4 ~ 5.5	V
Control Input Voltage	High	$V_{IH}$	2	V
	Low	$V_{IL}$	0.8	V
Input Clamp Current		$I_{IK}$	-50	mA
Continuous Channel Current		$I_{CH}$	128	mA
Power Dissipation $T_{OPR} = -40^\circ\text{C}$ to $+125^\circ\text{C}$	SOP-14	$P_D$	600	mW
	TSSOP-14		500	
Operating Temperature		$T_{OPR}$	-40 ~ +85	$^\circ\text{C}$
Storage Temperature		$T_{STG}$	-65 ~ +150	$^\circ\text{C}$

Note: 1. Absolute maximum ratings are those values beyond which the device could be permanently damaged.

Absolute maximum ratings are stress ratings only and functional device operation is not implied.

2. The input and output voltage ratings may be exceeded if the input and output current ratings are observed.

■ THERMAL DATA

PARAMETER		SYMBOL	RATINGS	UNIT
Junctions to Ambient	SOP-14	$\theta_{JA}$	139	$^\circ\text{C}/\text{W}$
	TSSOP-14		170	

■ ELECTRICAL CHARACTERISTICS ( $T_A = 25^\circ\text{C}$ ,  $V_{CC} = 5\text{V}$ , unless otherwise specified)

PARAMETER	SYMBOL	TEST CONDITIONS	MIN	TYP	MAX	UNIT
Digital Input Diode Voltage	$V_{IK}$	$V_{CC} = 4.5\text{V}$ , $I_I = -18\text{mA}$			-1.2	V
Input Leakage Current (OE inputs)	$I_{I(\text{LEAK})}$	$V_{CC} = 5.5\text{V}$ , $V_{IN} = 5.5\text{V}$ or GND			$\pm 1$	$\mu\text{A}$
Quiescent Supply Current	$I_{CC}$	$V_{CC} = 5.5\text{V}$ , $V_{IN} = 5.5\text{V}$ or GND, $I_{OUT} = 0$			3	$\mu\text{A}$
Additional quiescent Supply Current	$\Delta I_{CC}$	$V_{CC} = 5.5\text{V}$ , One input at 3.4V, Other inputs at $V_{CC}$ or GND			2.5	mA
Input Capacitance (OE)	$C_{IN}$	$V_{IN} = 3\text{V}$ or GND		3		pF
I/O Capacitance (OFF)	$C_{IO}$	$V_{OUT} = 3\text{V}$ or GND, OE = GND		4		pF
Resistor between two ports	$r_{on}$	$V_{CC} = 4\text{V}$ , $V_{IN} = 2.4\text{V}$ , $I_{IN} = 15\text{mA}$ , TYP at $V_{CC} = 4\text{V}$		16	22	$\Omega$
		$V_{CC} = 4.5\text{V}$ , $V_{IN} = 0\text{V}$ , $I_{IN} = 64\text{mA}$		5	7	
		$V_{CC} = 4.5\text{V}$ , $V_{IN} = 0\text{V}$ , $I_{IN} = 30\text{mA}$		5	7	
		$V_{CC} = 4.5\text{V}$ , $V_{IN} = 2.4\text{V}$ , $I_{IN} = 15\text{mA}$		10	15	

■ SWITCHING CHARACTERISTICS ( $T_A = 25^\circ\text{C}$ )

PARAMETER	SYMBOL	TEST CONDITIONS	MIN	MAX	UNIT
Propagation delay from input A (or B) to output B (or A)	$t_{PLH}/t_{PHL}$ ( $t_{pd}$ )	$C_L = 50\text{pF}$ , $R_L = 500\Omega$	$V_{CC} = 4\text{V}$	0.35	ns
			$V_{CC} = 5 \pm 0.5\text{V}$	0.25	
Propagation delay from input OE to output A or B	$t_{PZL}/t_{PZH}$ ( $t_{en}$ )		$V_{CC} = 4\text{V}$	5.4	ns
			$V_{CC} = 5 \pm 0.5\text{V}$	1.6	
Propagation delay from input OE to output A or B	$t_{PLZ}/t_{PHZ}$ ( $t_{dis}$ )	$V_{CC} = 4\text{V}$	5	ns	
		$V_{CC} = 5 \pm 0.5\text{V}$	1		4.5

## ■ TEST CIRCUIT AND WAVEFORMS

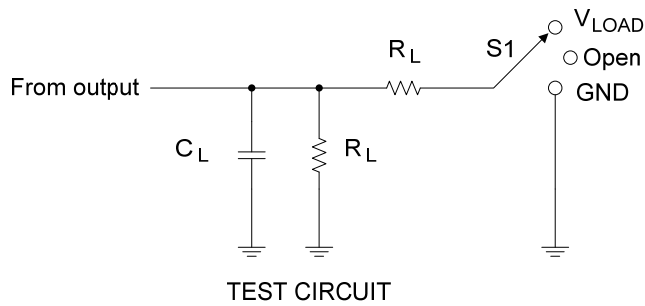

TEST	S1
$t_{PLH}/t_{PHL}$	Open
$t_{PLZ}/t_{PZL}$	$V_{LOAD}$
$t_{PHZ}/t_{PZH}$	Open

$V_{CC}$	Inputs		$V_M$	$V_{LOAD}$	$C_L$	$R_L$	$V_{\Delta}$
	$V_{IN}$	$t_r, t_f$					
4V	$V_{CC}$	$\leq 2.5ns$	1.5V	7V	50pF	500 $\Omega$	0.3V
5V $\pm$ 0.5V	$V_{CC}$	$\leq 2.5ns$	1.5V	7V	50pF	500 $\Omega$	0.3V

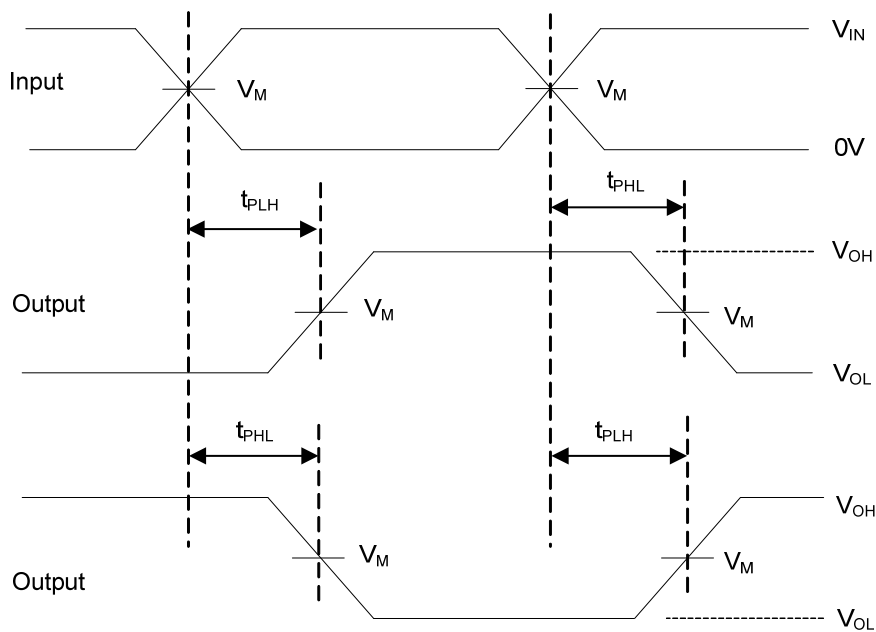

Voltage waveforms Propagation delay times

## ■ TEST CIRCUIT AND WAVEFORMS(Cont.)

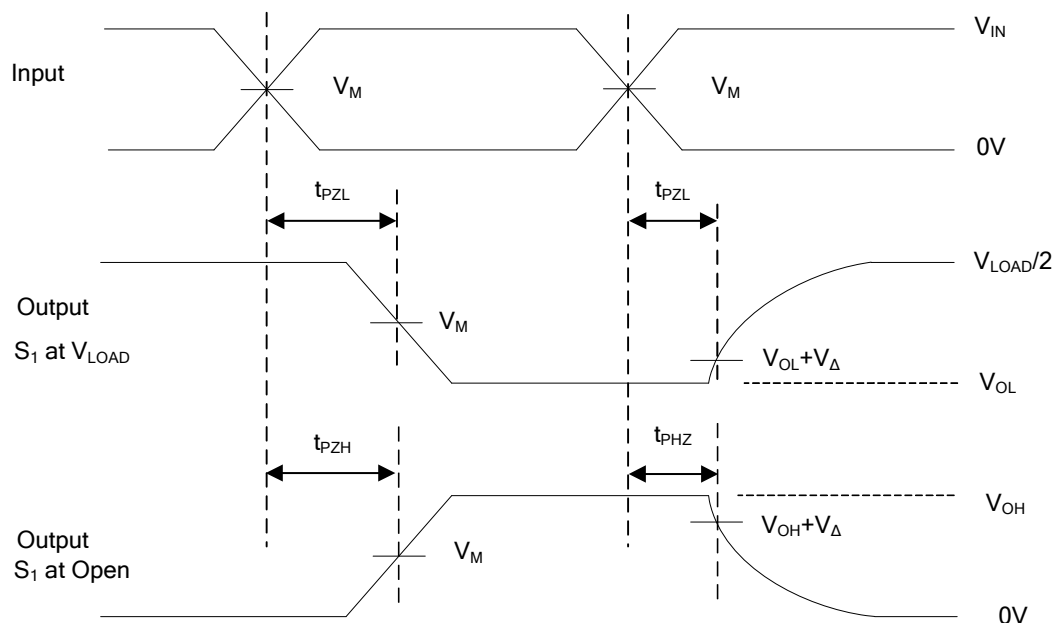

VOLTAGE WAVEFORMS ENABLE AND DISABLE TIMES

Notes: 1. C<sub>L</sub> includes probe and jig capacitance.

2. All input pulses are supplied by generators having the following characteristics: PRR ≤10MHz, Z<sub>O</sub> = 50Ω.

UTC assumes no responsibility for equipment failures that result from using products at values that exceed, even momentarily, rated values (such as maximum ratings, operating condition ranges, or other parameters) listed in products specifications of any and all UTC products described or contained herein. UTC products are not designed for use in life support appliances, devices or systems where malfunction of these products can be reasonably expected to result in personal injury. Reproduction in whole or in part is prohibited without the prior written consent of the copyright owner. The information presented in this document does not form part of any quotation or contract, is believed to be accurate and reliable and may be changed without notice.