



## U74HC138

CMOS IC

### 3-TO-8 LINE DECODERS / DEMULTIPLEXERS

#### DESCRIPTION

The **U74HC138** decodes a three-bit Address to 1-of-8 active-low outputs.

This device features three Chip Select inputs, two active-low and one active-high, to facilitate the demultiplexing, cascading, and chip-selecting functions.

The demultiplexing function is accomplished by using the address inputs to select the desired device output. One of the Chip Selects is used as a data input while the other Chip Selects are held in their active states.

#### FEATURES

- \* Operate from 2.0V ~ 6.0V
- \* Low Input Current: 100nA Max
- \* Low Quiescent Current: 8µA Max
- \* Typ  $t_{PD}$ =15ns
- \* Output Drive:4mA @ 5V

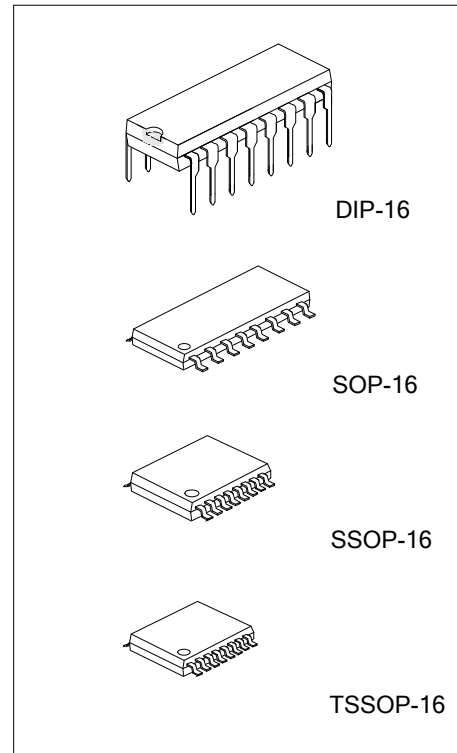

#### ORDERING INFORMATION

Ordering Number		Package	Packing
Lead Free	Halogen Free		
U74HC138L-D16-T	U74HC138G-D16-T	DIP-16	Tube
U74HC138L-S16-R	U74HC138G-S16-R	SOP-16	Tape Reel
U74HC138L-R16-R	U74HC138G-R16-R	SSOP-16	Tape Reel
U74HC138L-P16-R	U74HC138G-P16-R	TSSOP-16	Tape Reel

<p>U74HC138G-D16-T</p> <p>(1) Packing Type</p> <p>(2) Package Type</p> <p>(3) Green Package</p>	<p>(1) T: Tube, R: Tape Reel</p> <p>(2) D16: DIP-16, S16: SOP-16, R16: SSOP-16, P16: TSSOP-16</p> <p>(3) G: Halogen Free and Lead Free, L: Lead Free</p>
---	--

MARKING

Package	Marking
DIP-16	
SOP-16 TSSOP-16	
SSOP-16	

PIN CONFIGURATION

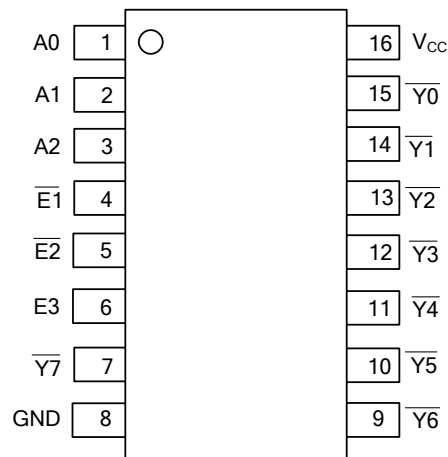

FUNCTION TABLE

INPUTS						OUTPUTS							
$\overline{E1}$	$\overline{E2}$	E3	A0	A1	A2	$\overline{Y0}$	$\overline{Y1}$	$\overline{Y2}$	$\overline{Y3}$	$\overline{Y4}$	$\overline{Y5}$	$\overline{Y6}$	$\overline{Y7}$
H	X	X	X	X	X	H	H	H	H	H	H	H	H
X	H	X	X	X	X	H	H	H	H	H	H	H	H
X	X	L	X	X	X	H	H	H	H	H	H	H	H
L	L	H	L	L	L	L	H	H	H	H	H	H	H
L	L	H	H	L	L	H	L	H	H	H	H	H	H
L	L	H	L	H	L	H	H	L	H	H	H	H	H
L	L	H	H	H	L	H	H	H	L	H	H	H	H
L	L	H	L	L	H	H	H	H	H	L	H	H	H
L	L	H	H	L	H	H	H	H	H	H	L	H	H
L	L	H	L	H	H	H	H	H	H	H	H	L	H
L	L	H	H	H	H	H	H	H	H	H	H	H	L

Note: H: High voltage level    L: Low voltage level    X: Don't care

■ LOGIC SYMBOL

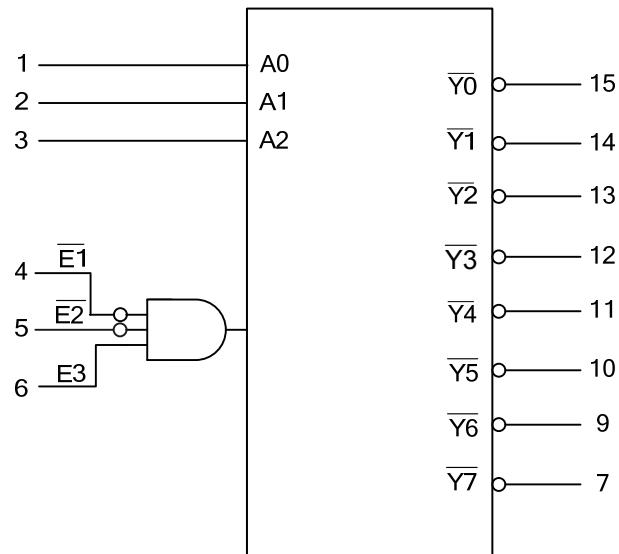

■ LOGIC DIAGRAM

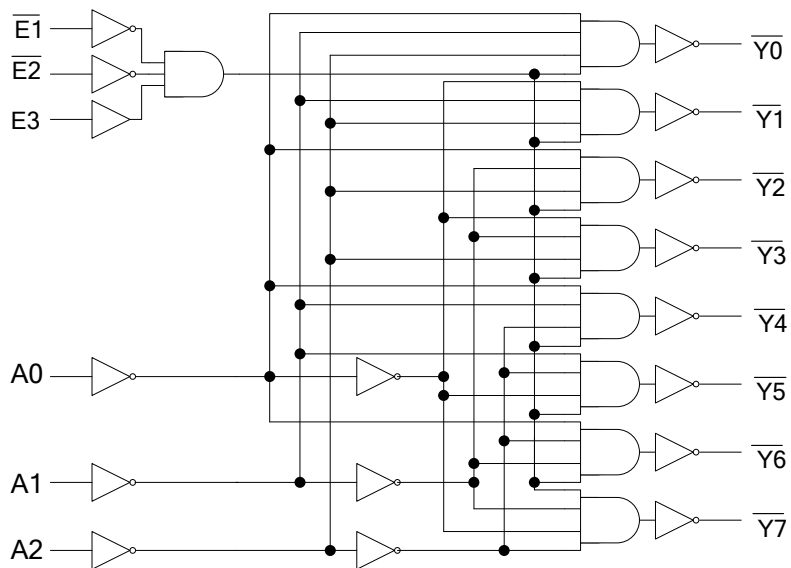

### ■ ABSOLUTE MAXIMUM RATING

PARAMETER	SYMBOL	RATINGS	UNIT
Supply Voltage	$V_{CC}$	-0.5 ~ 7.0	V
Input Clamp Current( $V_I < 0$ or $V_I > V_{CC}$ )	$I_{IK}$	$\pm 20$	mA
Output Clamp Current( $V_O < 0$ or $V_O > V_{CC}$ )	$I_{OK}$	$\pm 20$	mA
Continuous Output Current( $V_O = 0 \sim V_{CC}$ )	$I_O$	$\pm 25$	mA
$V_{CC}$ or GND Current	$I_{CC}$	$\pm 50$	mA
Storage Temperature	$T_{STG}$	-65 ~ + 150	$^{\circ}C$

Note: Absolute maximum ratings are those values beyond which the device could be permanently damaged.  
 Absolute maximum ratings are stress ratings only and functional device operation is not implied.

### ■ RECOMMENDED OPERATING CONDITIONS

PARAMETER	SYMBOL	TEST CONDITIONS	MIN	TYP	MAX	UNIT
Supply Voltage	$V_{CC}$	Operating	2.0	5.0	6.0	V
Input Voltage	$V_{IN}$		0		$V_{CC}$	V
Output Voltage	$V_{OUT}$		0		$V_{CC}$	V
Operating Temperature	$T_A$		-40		+85	$^{\circ}C$
Input Rise or Fall Times	$t_R, t_F$	$V_{CC}=2.0V$			1000	ns
		$V_{CC}=4.5V$			500	
		$V_{CC}=6.0V$			400	

### ■ THERMAL CHARACTERISTICS

PARAMETER	SYMBOL	RATINGS	UNIT	
Junction to Ambient	$\theta_{JA}$	DIP-16	67	$^{\circ}C/W$
		SOP-16	73	
		SSOP-16	90	
		TSSOP-16	108	

### ■ ELECTRICAL CHARACTERISTICS ( $T_A=25^{\circ}C$ )

PARAMETER	SYMBOL	TEST CONDITIONS	MIN	TYP	MAX	UNIT
High-level input voltage	$V_{IH}$	$V_{CC}=2V$	1.5			V
		$V_{CC}=4.5V$	3.15			V
		$V_{CC}=6V$	4.2			V
Low-level output voltage	$V_{IL}$	$V_{CC}=2V$			0.5	V
		$V_{CC}=4.5V$			1.35	V
		$V_{CC}=6V$			1.8	V
High-Level Output Voltage	$V_{OH}$	$V_{CC}=2V, I_{OH}=-20\mu A$	1.9	1.998		V
		$V_{CC}=4.5V, I_{OH}=-20\mu A$	4.4	4.499		V
		$V_{CC}=6V, I_{OH}=-20\mu A$	5.9	5.999		V
		$V_{CC}=4.5V, I_{OH}=-4.0mA$	3.98	4.3		V
		$V_{CC}=6V, I_{OH}=-5.2mA$	5.48	5.8		V
Low-Level Output Voltage	$V_{OL}$	$V_{CC}=2V, I_{OL}=20\mu A$		0.002	0.1	V
		$V_{CC}=4.5V, I_{OL}=20\mu A$		0.001	0.1	V
		$V_{CC}=6V, I_{OL}=20\mu A$		0.001	0.1	V
		$V_{CC}=4.5V, I_{OL}=4mA$		0.17	0.26	V
		$V_{CC}=6V, I_{OL}=5.2mA$		0.15	0.26	V
Input Leakage Current	$I_{I(LEAK)}$	$V_{CC}=6V, V_{IN}=V_{CC}$ or GND		$\pm 0.1$	$\pm 100$	nA
Quiescent Supply Current	$I_{CC}$	$V_{CC}=6V, V_{IN}=V_{CC}$ or GND, $I_{OUT}=0$			8	$\mu A$
Input Capacitance	$C_I$	$V_{CC}=2\sim 6V$		3	10	pF

■ SWITCHING CHARACTERISTICS (T<sub>A</sub>=25°C, C<sub>L</sub>=50pF, see Test Circuit and Waveforms)

PARAMETER	SYMBOL	TEST CONDITIONS	MIN	TYP	MAX	UNIT
Propagation delay from input (A <sub>n</sub> ) to output( $\overline{Y}_n$ )	t <sub>PLH</sub> /t <sub>PHL</sub>	V <sub>CC</sub> =2.0V		67	180	ns
		V <sub>CC</sub> =4.5V		18	36	ns
		V <sub>CC</sub> =6.0V		15	31	ns
Propagation delay from input (E3) to output( $\overline{Y}_n$ )	t <sub>PLH</sub> /t <sub>PHL</sub>	V <sub>CC</sub> =2.0V		66	155	ns
		V <sub>CC</sub> =4.5V		18	31	ns
		V <sub>CC</sub> =6.0V		15	26	ns
Propagation delay from input ( $\overline{E}_n$ ) to output( $\overline{Y}_n$ )	t <sub>PLH</sub> /t <sub>PHL</sub>	V <sub>CC</sub> =2.0V		66	155	ns
		V <sub>CC</sub> =4.5V		18	31	ns
		V <sub>CC</sub> =6.0V		15	26	ns
Output Transition Time	t <sub>TLH</sub> /t <sub>THL</sub>	V <sub>CC</sub> =2.0V		38	75	ns
		V <sub>CC</sub> =4.5V		8	15	ns
		V <sub>CC</sub> =6.0V		6	13	ns

■ OPERATING CHARACTERISTICS

PARAMETER	SYMBOL	TEST CONDITIONS	MIN	TYP	MAX	UNIT
Power Dissipation Capacitance	C <sub>PD</sub>	No Load		85		pF

■ TEST CIRCUIT AND WAVEFORMS

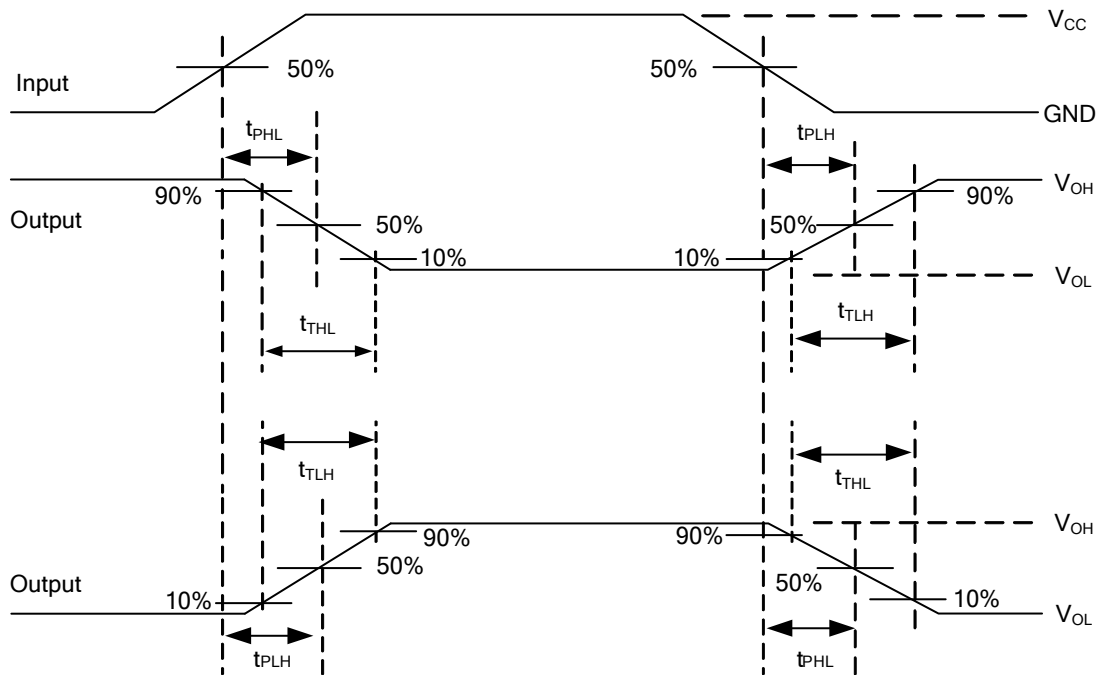
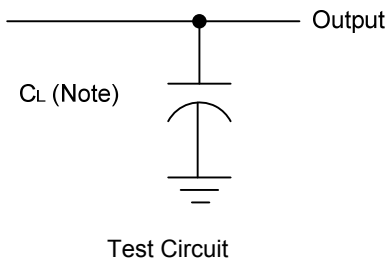

Propagation Delay and Output Transition Times

Note:  $C_L$  includes probe and jig capacitance.

All input pulses are supplied by generators having the following characteristics:  $Z_O = 50\Omega$ ,  $t_R = 6ns$ ,  $t_F = 6ns$ .

UTC assumes no responsibility for equipment failures that result from using products at values that exceed, even momentarily, rated values (such as maximum ratings, operating condition ranges, or other parameters) listed in products specifications of any and all UTC products described or contained herein. UTC products are not designed for use in life support appliances, devices or systems where malfunction of these products can be reasonably expected to result in personal injury. Reproduction in whole or in part is prohibited without the prior written consent of the copyright owner. UTC reserves the right to make changes to information published in this document, including without limitation specifications and product descriptions, at any time and without notice. This document supersedes and replaces all information supplied prior to the publication hereof.