



U74HC1G06

CMOS IC

SINGLE INVERTER WITH OPEN-DRAIN OUTPUTS

DESCRIPTION

The **U74HC1G06** is a single inverting buffer with open-drain outputs and it provides the function $Y = \overline{A}$ in positive logic.

For digital operation the outputs of this device must have a pull-up resistor to establish a logic HIGH-level.

FEATURES

- * Wide supply voltage range from 2V to 6V
- * High noise immunity
- * Low power dissipation; $I_{CC} = 1\mu A$ (Max.)
- * Typical $t_{PD} = 6ns$ at $V_{CC} = 6V$

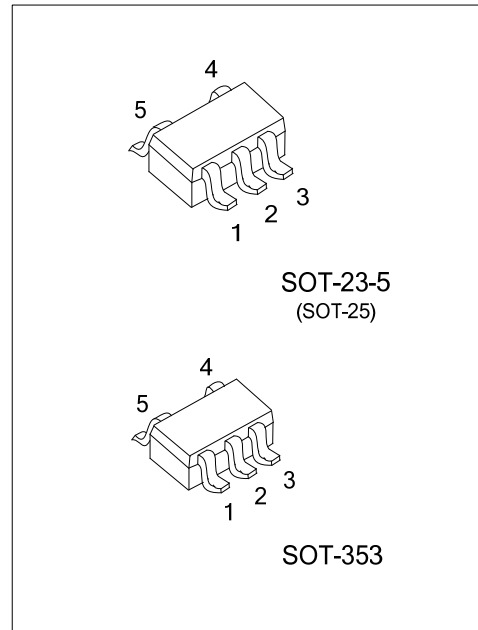

ORDERING INFORMATION

Ordering Number		Package	Packing
Lead Free Plating	Halogen Free		
U74HC1G06L-AE5-R	U74HC1G06G-AE5-R	SOT-23-5	Tape Reel
U74HC1G06L-AL5-R	U74HC1G06G-AL5-R	SOT-353	Tape Reel

<p>U74HC1G06L-AE5-R</p> <p>(1) Packing Type (2) Package Type (3) Lead Free</p>	<p>(1) R: Tape Reel (2) AE5: SOT-23-5, AL5: SOT-353 (3) L: Lead Free, G: Halogen Free</p>
--	---

MARKING

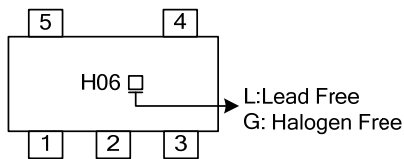

■ PIN CONFIGURATION

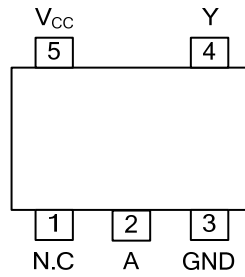

■ FUNCTION TABLE

INPUT(A)	OUTPUT(Y)
H	L
L	Z

Note: H: HIGH voltage level; L: LOW voltage level; Z: high impedance state.

■ LOGIC DIAGRAM (positive logic)

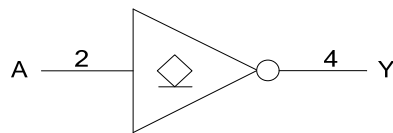

Logic symbol

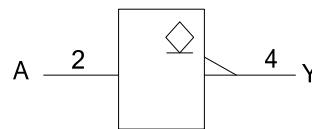

IEC logic symbol

■ ABSOLUTE MAXIMUM RATING

PARAMETER	SYMBOL	RATINGS	UNIT
Supply Voltage	V_{CC}	-0.5 ~ 7.0	V
Input Voltage	V_{IN}	-0.5 ~ $V_{CC} + 0.5$	V
Output Voltage	V_{OUT}	-0.5 ~ $V_{CC} + 0.5$	V
V_{CC} or GND Current	I_{CC}	±50	mA
Continuous Output Current ($V_{OUT}=0$ to V_{CC})	I_{OUT}	±25	mA
Input Clamp Current ($V_{IN}<0$)	I_{IK}	±20	mA
Output Clamp Current ($V_{OUT}<0$)	I_{OK}	±20	mA
Storage Temperature Range	T_{STG}	-65 ~ +150	°C

Note: Absolute maximum ratings are those values beyond which the device could be permanently damaged.

Absolute maximum ratings are stress ratings only and functional device operation is not implied.

■ RECOMMENDED OPERATING CONDITIONS

PARAMETER	SYMBOL	TEST CONDITIONS	MIN	TYP	MAX	UNIT
Supply Voltage	V_{CC}		2		6	V
Input Voltage	V_{IN}		0		V_{CC}	V
Output Voltage	V_{OUT}		0		V_{CC}	V
Low-level Output Current	I_{OL}	$V_{CC}=2.0V$			20	µA
		$V_{CC}=4.5V$			20	µA
		$V_{CC}=6.0V$			20	µA
		$V_{CC}=4.5V$			4.0	mA
		$V_{CC}=6.0V$			5.2	mA
Operating Temperature	T_A		-40		85	°C
Input Transition Rise or Fall Rate	$\Delta t/\Delta v$	$V_{CC}=2.0V$			500	ns/V
		$V_{CC}=4.5V$			112	
		$V_{CC}=6.0V$			67	

■ ELECTRICAL CHARACTERISTICS ($T_A=25^\circ C$, unless otherwise specified)

PARAMETER	SYMBOL	TEST CONDITIONS	MIN	TYP	MAX	UNIT
High-level Input Voltage	V_{IH}	$V_{CC}=2.0V$	1.5			V
		$V_{CC}=4.5V$	3.15			V
		$V_{CC}=6.0V$	4.2			V
Low-level Input Voltage	V_{IL}	$V_{CC}=2.0V$			0.5	V
		$V_{CC}=4.5V$			1.35	V
		$V_{CC}=6.0V$			1.8	V
Low-Level Output Voltage	V_{OL}	$V_{CC}=2.0V$	$I_{OL}=20\mu A$	0	0.1	V
		$V_{CC}=4.5V$		0	0.1	V
		$V_{CC}=6.0V$		0	0.1	V
		$V_{CC}=4.5V$	$I_{OL}=4.0mA$	0.17	0.26	V
		$V_{CC}=6.0V$	$I_{OL}=5.2mA$	0.18	0.26	V
Input Leakage Current	$I_{I(LEAK)}$	$V_{CC}=0\sim 6V, V_{IN}=V_{CC}$ or GND			±0.1	µA
Output Leakage Current	I_{OZ}	$V_{CC}=6.0V, V_{IN}=V_{IL}$ or $V_{IH}, V_{OUT}=V_{CC}$ or GND			±0.5	µA
Quiescent Supply Current	I_{CC}	$V_{CC}=6.0V, V_{IN}=V_{CC}$ or GND, $I_{OUT}=0$			1.0	µA
Input Capacitance	C_I	$V_{CC}=5.0V$		5		pF
Output Capacitance	C_{OUT}	$V_{CC}=5.0V$		3		pF

■ SWITCHING CHARACTERISTICS (T_A=25°C)

See Fig. 1 and Fig. 2 for test circuit and waveforms.

PARAMETER	SYMBOL	TEST CONDITIONS	MIN	TYP	MAX	UNIT
Output transition time	t _{THL}	V _{CC} =2.0V		30	75	ns
		V _{CC} =4.5V		8	15	
		V _{CC} =6.0V		7	13	
Propagation delay from input (A) to output(Y)	t _{PLZ}	V _{CC} =2.0V, C _L =50pF, R _L =1kΩ		10	90	ns
		V _{CC} =4.5V		7	18	
		V _{CC} =6.0V		6	15	
Propagation delay from input (A) to output(Y)	t _{PZL}	V _{CC} =2.0V, C _L =50pF, R _L =1kΩ		17	90	ns
		V _{CC} =4.5V		7	18	
		V _{CC} =6.0V		5	15	

■ OPERATING CHARACTERISTICS (T_A=25°C)

PARAMETER	SYMBOL	TEST CONDITIONS	MIN	TYP	MAX	UNIT
Power Dissipation Capacitance	C _{PD}	V _{CC} =5.0V, C _L =50pF, f = 1MHz		4.0		pF

■ TEST CIRCUIT AND WAVEFORMS

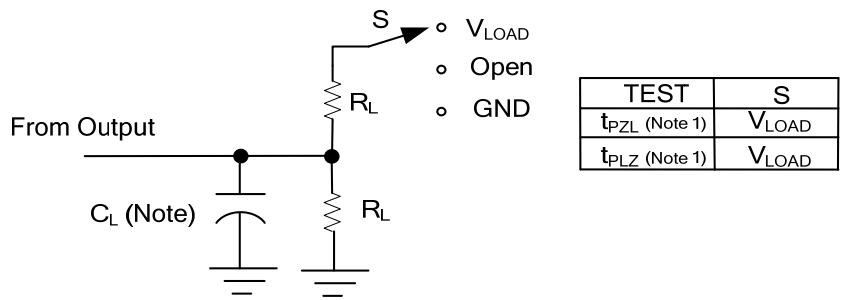

Note: 1. Since this device has open drain outputs, the t_{PLZ} and t_{PZL} is the same as t_{PLH} and t_{PHL} .

Fig. 1 LOAD CIRCUITRY FOR SWITCHING TIMES

V_{CC}	V_{IN}	t_R / t_F	V_M	V_{LOAD}	C_L	R_L	V_{Δ}
$V_{CC}=2.0V$	V_{CC}	6ns	$V_{CC}/2$	$2 \times V_{CC}$	50pF	1k Ω	0.3V
$V_{CC}=4.5V$	V_{CC}	6ns	$V_{CC}/2$	$2 \times V_{CC}$	50pF	1k Ω	0.3V
$V_{CC}=6.0V$	V_{CC}	6ns	$V_{CC}/2$	$2 \times V_{CC}$	50pF	1k Ω	0.3V

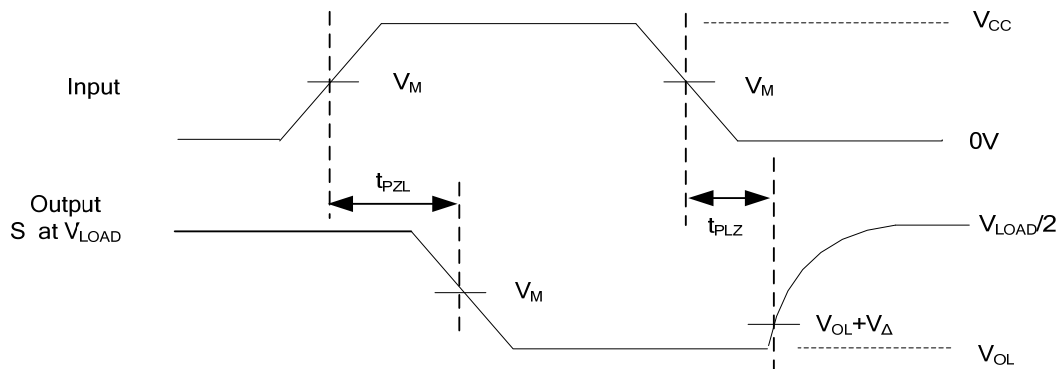

Fig. 2 PROPAGATION DELAY FROM INPUT(A) TO OUTPUT(Y) AND OUTPUT TRANSITION TIME

Note: 1. C_L includes probe and jig capacitance.

2. All input pulses are supplied by generators having the following characteristics: PRR ≤ 10 MHz, $Z_o = 50\Omega$.

UTC assumes no responsibility for equipment failures that result from using products at values that exceed, even momentarily, rated values (such as maximum ratings, operating condition ranges, or other parameters) listed in products specifications of any and all UTC products described or contained herein. UTC products are not designed for use in life support appliances, devices or systems where malfunction of these products can be reasonably expected to result in personal injury. Reproduction in whole or in part is prohibited without the prior written consent of the copyright owner. The information presented in this document does not form part of any quotation or contract, is believed to be accurate and reliable and may be changed without notice.