



U74HC1G66

CMOS IC

BILATERAL SWITCH

DESCRIPTION

The UTC **U74HC1G66** is a high-speed Si-gate CMOS device that provides an analog switch. The switch has two input/output pins(Y and Z) and an active high enable input pin (E). When pin E is low, the analog switch is turned off.

FEATURES

- * Operation voltage range: 2V~9V
- * Very low ON-resistance
- * Low power dissipation
- * Very small 5 pins package

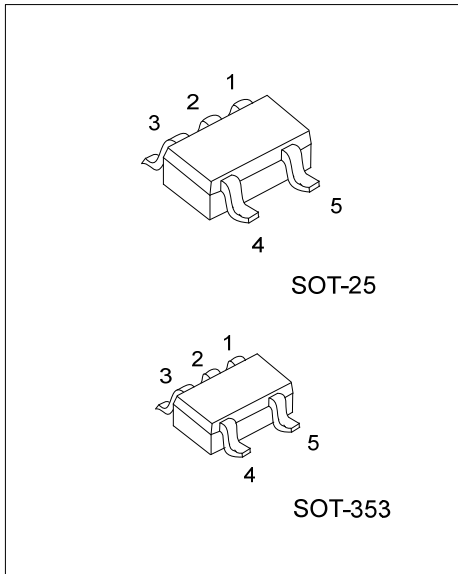

ORDERING INFORMATION

Order Number		Package	Packing
Lead Free	Halogen Free		
U74HC1G66L-AF5-R	U74HC1G66G-AF5-R	SOT-25	Tape Reel
U74HC1G66L-AL5-R	U74HC1G66G-AL5-R	SOT-353	Tape Reel

<p>U74HC1G66L-AF5-R</p>	<p>(1) R: Tape Reel (2) AF5: SOT-25, AL5: SOT-353 (3) G: Halogen Free, L: Lead Free</p>
-------------------------	---

MARKING

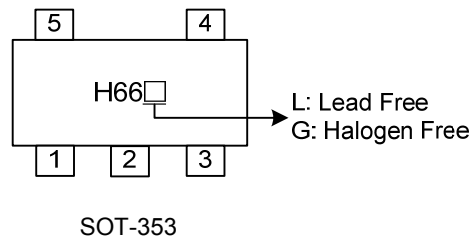
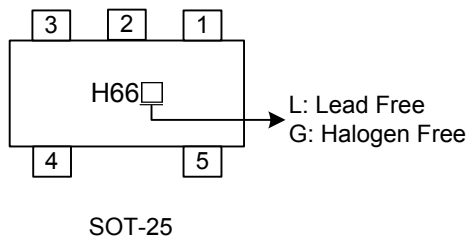

■ PIN CONFIGURATION

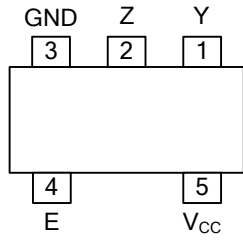

■ FUNCTION TABLE

INPUT(EN)	OUTPUT(Y/Z)
H	ON
L	OFF

Note: H: HIGH voltage level; L: LOW voltage level.

■ LOGIC DIAGRAM

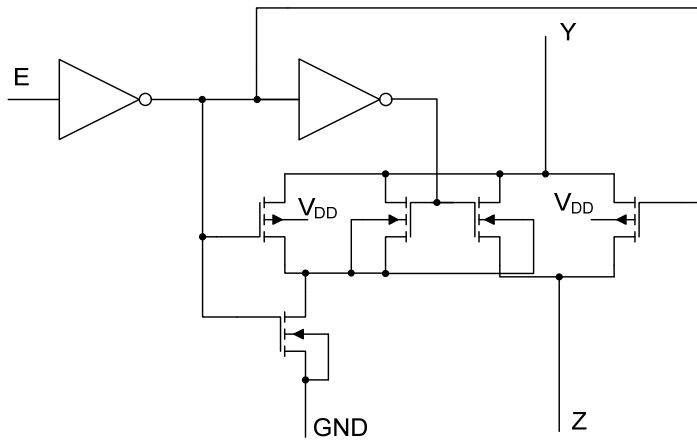

■ ABSOLUTE MAXIMUM RATINGS (unless otherwise specified)

PARAMETER	SYMBOL	RATINGS	UNIT
Supply Voltage	V_{CC}	-0.5~11	V
V_{CC} or GND Current	I_{CC}	± 50	mA
Input Clamp Current	I_{IK}	± 20	mA
Switch Diode Current	I_{SK}	± 20	mA
Switch Current	I_S	± 25	mA
Power Dissipation	P_D	200	mW
Derate above $T_a > 55^\circ\text{C}$		2.5	mW/K
Operating Temperature	T_{OPR}	-40 ~ + 125	$^\circ\text{C}$
Storage Temperature	T_{STG}	-65 ~ +150	$^\circ\text{C}$

Note: Absolute maximum ratings are those values beyond which the device could be permanently damaged. Absolute maximum ratings are stress ratings only and functional device operation is not implied.

■ RECOMMENDED OPERATING CONDITIONS

PARAMETER	SYMBOL	CONDITIONS	MIN	TYP	MAX	UNIT
Supply Voltage	V_{CC}		2.0	5.0	10.0	V
Input Voltage	V_{IN}		GND		V_{CC}	V
Switch voltage	V_S		GND		V_{CC}	V
Input Transition Rise or Fall Rate	t_R, t_F	$V_{CC}=2.0\text{V}$			1000	ns
		$V_{CC}=4.5\text{V}$		6	500	ns
		$V_{CC}=6.0\text{V}$			400	ns
		$V_{CC}=10.0\text{V}$			250	ns

■ STATIC CHARACTERISTICS ($T_a=25^\circ\text{C}$)

PARAMETER	SYMBOL	TEST CONDITIONS	MIN	TYP	MAX	UNIT
High-Level Input Voltage	V_{IH}	$V_{CC}=2\text{V}$	1.5			V
		$V_{CC}=4.5\text{V}$	3.15			V
		$V_{CC}=6\text{V}$	4.2			V
		$V_{CC}=9\text{V}$	6.3			V
Low-Level Input Voltage	V_{IL}	$V_{CC}=2\text{V}$			0.5	V
		$V_{CC}=4.5\text{V}$			1.35	V
		$V_{CC}=6\text{V}$			1.8	V
		$V_{CC}=9\text{V}$			2.7	V
Input Leakage Current	$I_{I(LEAK)}$	$V_{CC}=6\text{V}, V_{IN}=V_{CC}$ or GND		0.1	1	μA
		$V_{CC}=10\text{V}, V_{IN}=V_{CC}$ or GND		0.2	2	μA
Quiescent Supply Current	I_Q	$V_{CC}=6\text{V}, V_{IN}=V_{CC}$ or GND, $V_{IS}=\text{GND}$ or $V_{CC}, V_{OS}=V_{CC}$ or GND		1	10	μA
		$V_{CC}=10\text{V}, V_{IN}=V_{CC}$ or GND, $V_{IS}=\text{GND}$ or $V_{CC}, V_{OS}=V_{CC}$ or GND		2	20	μA
Analog Switch Current	OFF-state	I_S	$V_{CC}=10, V_{IN}=V_{IH}$ or $V_{IL}; V_S =V_{CC}-\text{GND}$		1	μA
	ON-state					
ON-Resistance	PEAK	$R_{ON(PEAK)}$	$V_{CC}=2.0\text{V}, I_S=100\mu\text{A}, V_{IS}=V_{CC}$ to GND; $V_{IN}=V_{IH}$ or $V_{IL};$			Ω
			$V_{CC}=4.5\text{V}, I_S=1\text{mA}, V_{IS}=V_{CC}$ to GND; $V_{IN}=V_{IH}$ or $V_{IL};$	42	118	Ω
			$V_{CC}=6.0\text{V}, I_S=1\text{mA}, V_{IS}=V_{CC}$ to GND; $V_{IN}=V_{IH}$ or $V_{IL};$	31	105	Ω
			$V_{CC}=9.0\text{V}, I_S=1\text{mA}, V_{IS}=V_{CC}$ to GND; $V_{IN}=V_{IH}$ or $V_{IL};$	23	88	Ω

■ STATIC CHARACTERISTICS(Cont.) ($T_a=25^\circ\text{C}$)

PARAMETER		SYMBOL	TEST CONDITIONS	MIN	TYP (Note)	MAX	UNIT
ON-Resistance	RAIL	$R_{ON(RAIL)}$	$V_{CC}=2.0\text{V}$, $I_S=100\mu\text{A}$, $V_{IS}=\text{GND}$; $V_{IN}=V_{IH}$ or V_{IL} ;		75		Ω
			$V_{CC}=4.5\text{V}$, $I_S=1\text{mA}$, $V_{IS}=\text{GND}$; $V_{IN}=V_{IH}$ or V_{IL} ;		29	95	Ω
			$V_{CC}=6.0\text{V}$, $I_S=1\text{mA}$, $V_{IS}=\text{GND}$; $V_{IN}=V_{IH}$ or V_{IL} ;		23	82	Ω
			$V_{CC}=9.0\text{V}$, $I_S=1\text{mA}$, $V_{IS}=\text{GND}$; $V_{IN}=V_{IH}$ or V_{IL} ;		18	70	Ω
			$V_{CC}=2.0\text{V}$, $I_S=100\mu\text{A}$, $V_{IS}=V_{CC}$; $V_{IN}=V_{IH}$ or V_{IL} ;		75		Ω
			$V_{CC}=4.5\text{V}$, $I_S=1\text{mA}$, $V_{IS}=V_{CC}$; $V_{IN}=V_{IH}$ or V_{IL} ;		35	106	Ω
			$V_{CC}=6.0\text{V}$, $I_S=1\text{mA}$, $V_{IS}=V_{CC}$; $V_{IN}=V_{IH}$ or V_{IL} ;		27	94	Ω
			$V_{CC}=9.0\text{V}$, $I_S=1\text{mA}$, $V_{IS}=V_{CC}$; $V_{IN}=V_{IH}$ or V_{IL} ;		21	78	Ω

■ DYNAMIC CHARACTERISTICS ($T_a=25^\circ\text{C}$, $C_L=50\text{pF}$, $\text{GND}=0$, $t_R=t_F=6\text{ns}$, unless otherwise specified)

PARAMETER	SYMBOL	TEST CONDITIONS	MIN	TYP (Note)	MAX	UNIT
Propagation Delay V_{IS} to V_{OS}	t_{PHL}/t_{PLH}	$V_{CC}=2.0\text{V}$, $R_L=\infty$		8	75	ns
		$V_{CC}=4.5\text{V}$, $R_L=\infty$		3	15	ns
		$V_{CC}=6.0\text{V}$, $R_L=\infty$		2	13	ns
		$V_{CC}=9.0\text{V}$, $R_L=\infty$		1	10	ns
Turn-ON Time E to V_{OS}	t_{PZH}/t_{PZL}	$V_{CC}=2.0\text{V}$, $R_L=1\text{K}\Omega$		50	125	ns
		$V_{CC}=4.5\text{V}$, $R_L=1\text{K}\Omega$		16	25	ns
		$V_{CC}=6.0\text{V}$, $R_L=1\text{K}\Omega$		13	21	ns
		$V_{CC}=9.0\text{V}$, $R_L=1\text{K}\Omega$		9	16	ns
Turn-OFF Time E to V_{OS}	t_{PHZ}/t_{PLZ}	$V_{CC}=2.0\text{V}$, $R_L=1\text{K}\Omega$		27	190	ns
		$V_{CC}=4.5\text{V}$, $R_L=1\text{K}\Omega$		16	38	ns
		$V_{CC}=6.0\text{V}$, $R_L=1\text{K}\Omega$		14	33	ns
		$V_{CC}=9.0\text{V}$, $R_L=1\text{K}\Omega$		12	16	ns

Note: All typical values are measured at $T_a=25^\circ\text{C}$

■ TEST CIRCUIT AND WAVEFORMS

Test circuit for measuring ON-resistance (Ron)

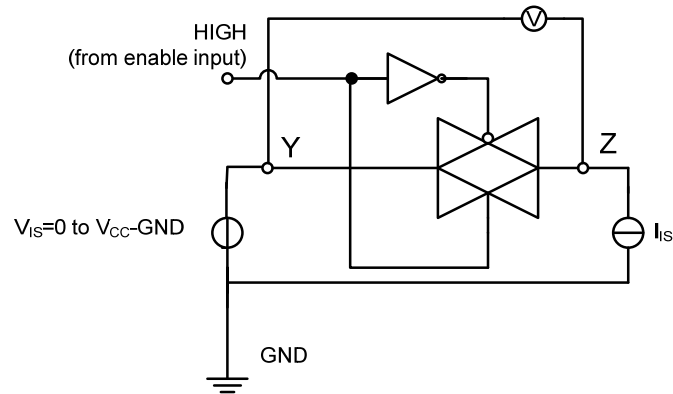

Test circuit for measuring OFF-state current

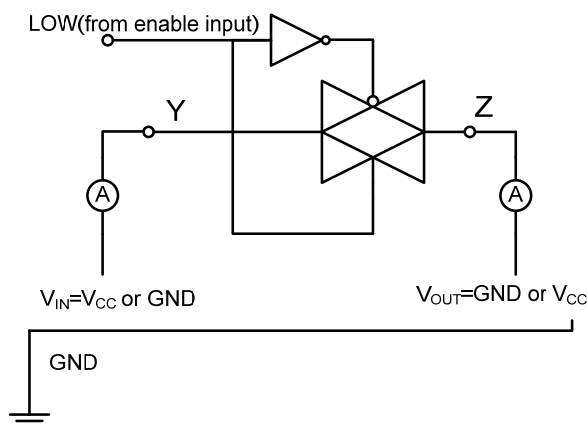

Test circuit for measuring ON-state current

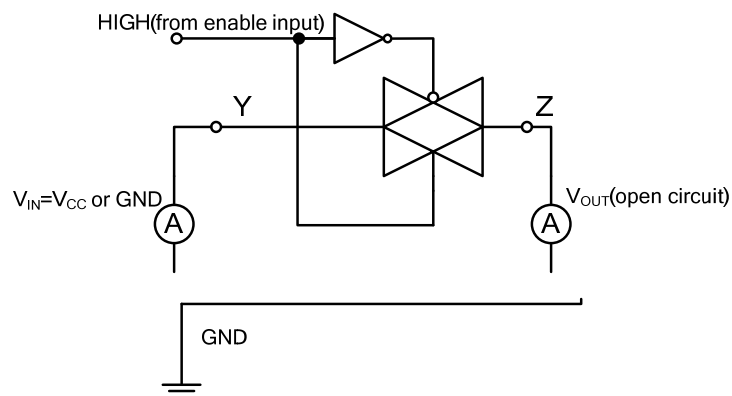

■ TEST CIRCUIT AND WAVEFORMS(Cont.)

Waveforms showing the Input (V_{IS}) to Output (V_{OS}) propagation delays

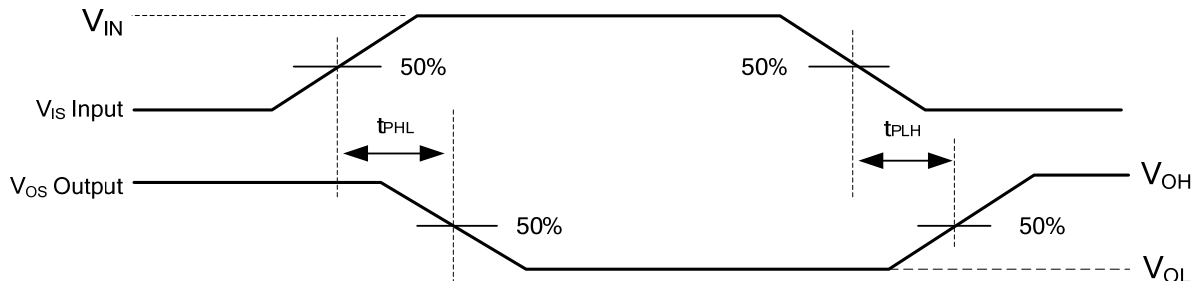

Waveforms showing the turn-on and turn-off times.

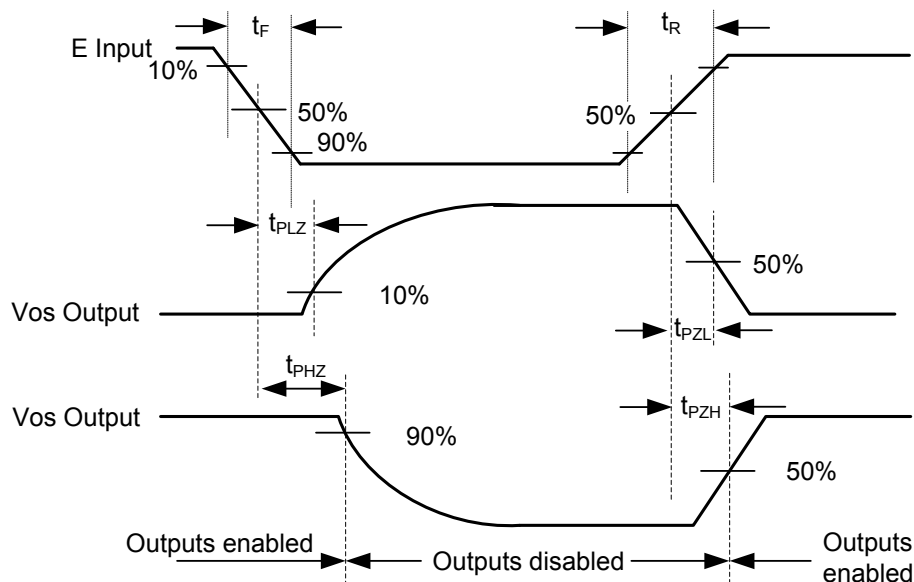

Note: $V_{IN} = \text{GND to } V_{CC}$

UTC assumes no responsibility for equipment failures that result from using products at values that exceed, even momentarily, rated values (such as maximum ratings, operating condition ranges, or other parameters) listed in products specifications of any and all UTC products described or contained herein. UTC products are not designed for use in life support appliances, devices or systems where malfunction of these products can be reasonably expected to result in personal injury. Reproduction in whole or in part is prohibited without the prior written consent of the copyright owner. The information presented in this document does not form part of any quotation or contract, is believed to be accurate and reliable and may be changed without notice.