

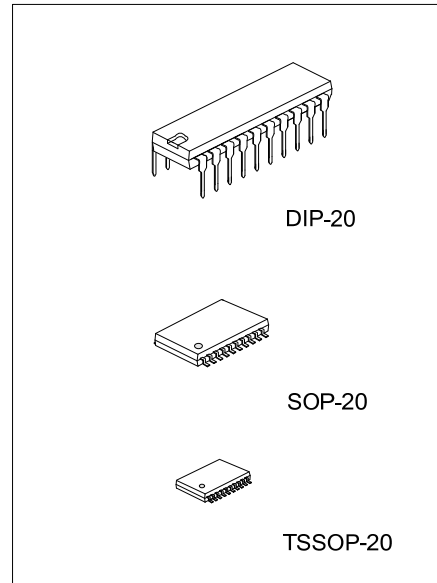

## U74HCT373

CMOS IC

### OCTAL TRANSPARENT D-TYPE LATCHES WITH 3-STATE OUTPUTS



#### DESCRIPTION

The **U74HCT373** is an octal transparent D-type latch with 3-state outputs, and it has 8 channels.

When the  $\overline{OE}$  input is low and the LE input is high, the Q outputs follow the D inputs. When  $\overline{OE}$  is low and LE is low, the Q outputs are latched at the logic levels of the D inputs.

When the  $\overline{OE}$  input is high, the outputs are in the high-impedance. The  $\overline{OE}$  does not affect the internal operations of the latches. Old data can be retained or new data can be entered while the outputs are in the high-impedance state.

To ensure the high-impedance state during power up or power down,  $\overline{OE}$  should be tied to  $V_{CC}$  through a pull-up resistor; the minimum value of the resistor is determined by the current-sinking capability of the driver.

#### FEATURES

- \* Inputs are TTL-Voltage Compatible
- \* Operate from 4.5V to 5.5V
- \* Inputs Accept Voltages to 5.5V
- \* Max  $t_{PD}$  of 21ns at  $V_{CC}=5.5V$ ,  $C_L=50pF$
- \* Typ.  $V_{OL} < 0.26V$  at  $V_{CC}=4.5V$ ,  $I_{OL}=6mA$ ,  $T_A=25^\circ C$
- \* Typ.  $V_{OH} > 3.94V$  at  $V_{CC}=4.5V$ ,  $I_{OH}=-6mA$ ,  $T_A=25^\circ C$

#### ORDERING INFORMATION

Ordering Number		Package	Packing
Lead Free	Halogen Free		
U74HCT373L-D20-T	U74HCT373G-D20-T	DIP-20	Tube
U74HCT373L-S20-R	U74HCT373G-S20-R	SOP-20	Tape Reel
U74HCT373L-P20-R	U74HCT373G-P20-R	TSSOP-20	Tape Reel

<p>U74HCT373G-D20-T</p> <p>(1)Packing Type (2)Package Type (3)Green Package</p>	<p>(1) T: Tube, R: Tape Reel (2) D20: DIP-20, S20: SOP-20, P20: TSSOP-20 (3) G: Halogen Free and Lead Free, L: Lead Free</p>
---	--

■ MARKING

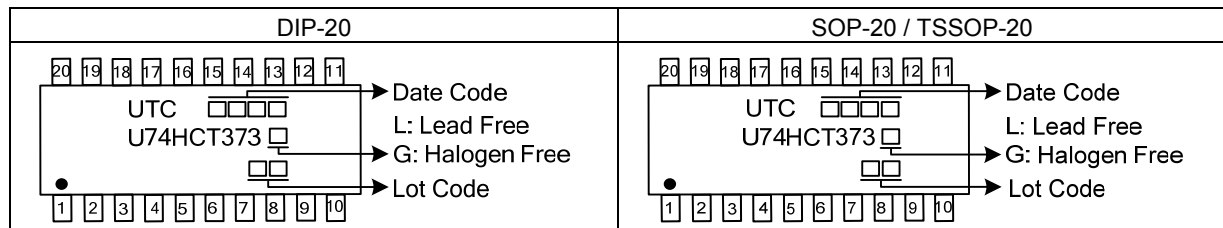

■ PIN CONFIGURATION

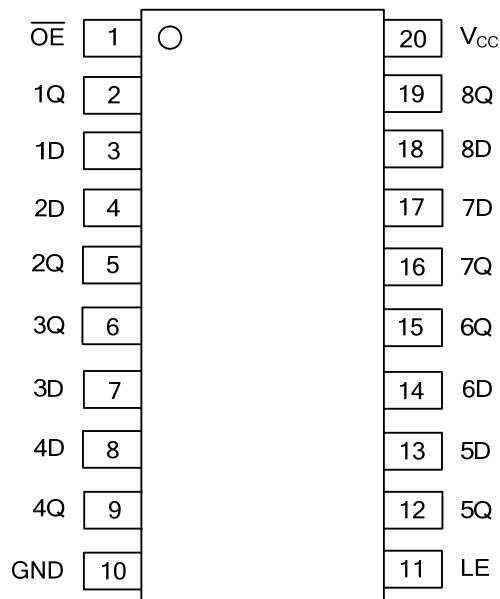

■ FUNCTION TABLE

INPUTS( $\overline{OE}$ )	INPUTS(LE)	INPUTS(D)	OUTPUT(Q)
L	H	H	H
L	H	L	L
L	L	X	$Q_0$
H	X	X	Z

Note: H: HIGH voltage level; L: LOW voltage level.

■ LOGIC SYMBOL

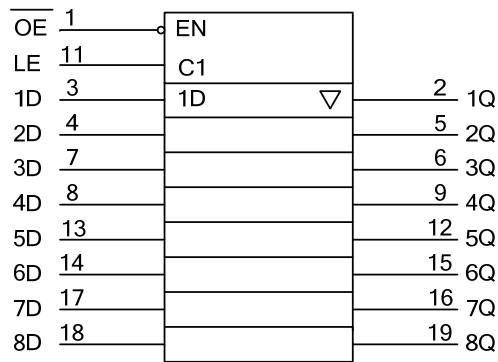

■ LOGIC DIAGRAM

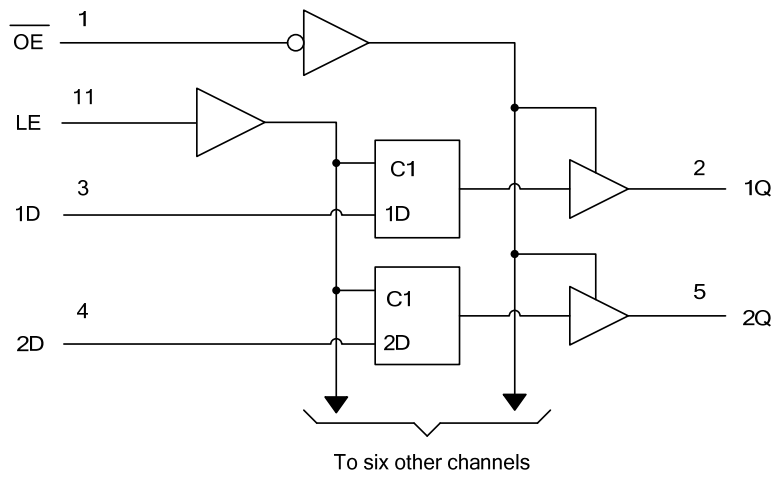

■ ABSOLUTE MAXIMUM RATING (Unless otherwise specified)

PARAMETER	SYMBOL	RATINGS	UNIT
Supply voltage	$V_{CC}$	-0.5 ~ 7	V
Input voltage (Note 3)	$V_I$	-0.5 ~ 7	V
Output voltage (Note 3)	$V_O$	-0.5 ~ $V_{CC} + 0.5$	V
Input clamp current	$I_{IK}$	±20	mA
Output clamp current	$I_{OK}$	±20	mA
Output current	$I_O$	±35	mA
$V_{CC}$ or GND current	$I_{CC}$	±70	mA
Storage temperature	$T_{STG}$	-65 ~ +150	°C

Notes: 1. Absolute maximum ratings are those values beyond which the device could be permanently damaged.

Absolute maximum ratings are stress ratings only and functional device operation is not implied.

2. The input and output voltage ratings may be exceeded if the input and output current ratings are observed.

■ RECOMMENDED OPERATING CONDITIONS

PARAMETER	SYMBOL	MIN	TYP	MAX	UNIT
Supply Voltage	$V_{CC}$	4.5		5.5	V
High-Level Input Voltage	$V_{IH}$	2			V
Low-Level Input Voltage	$V_{IL}$			0.8	V
Input Voltage	$V_{IN}$	0		5.5	V
Output Voltage	$V_{OUT}$	0		$V_{CC}$	V
Input Rise and Fall Times	$t_R, t_F$			500	ns/V
Operating free-air temperature	$T_A$	-40		+125	°C

■ ELECTRICAL CHARACTERISTICS (Unless otherwise specified)

PARAMETER	SYMBOL	TEST CONDITIONS	MIN	TYP	MAX	UNIT
Output Voltage High-Level	$V_{OH}$	$V_{CC}=4.5V, I_{OH}=-20\mu A$	4.4	4.499		V
		$V_{CC}=4.5V, I_{OH}=-6mA$	3.98	4.3		
Output Voltage Low-Level	$V_{OL}$	$V_{CC}=4.5V, I_{OL}=20\mu A$		0.001	0.1	V
		$V_{CC}=4.5V, I_{OL}=6mA$		0.17	0.26	
Input Leakage Current	$I_{I(LEAK)}$	$V_{CC}=5.5V, V_{IN}=0$ or $5.5V$		±0.1	±100	nA
Leakage Current (For Output in High-Impedance State)	$I_{OZ}$	$V_{CC}=5.5V, V_{IN}=V_{IH}$ or $V_{IH}, V_{OUT}=0$ or $5.5V$		±0.01	±0.5	μA
Quiescent Supply Current	$I_{CC}$	$V_{CC}=5.5V, V_{IN}=V_{CC}$ or $GND, I_{OUT}=0$			8	μA
Additional quiescent supply current	$\Delta I_{CC}$	$V_{CC}=5.5V, \text{one Input at } 0.5V \text{ or } 3.4V, \text{ Other Inputs at } V_{CC} \text{ or } GND$		1.4	2.4	mA
Input Capacitance	$C_I$	$V_{CC}=4.5V$ to $5V$		3	10	pF

■ SWITCHING CHARACTERISTICS (Unless otherwise specified)

PARAMETER	SYMBOL	TEST CONDITIONS	MIN	TYP	MAX	UNIT
From D to Q	$t_{PD}$ ( $t_{PLH}/t_{PHL}$ )	$V_{CC}=4.5V, C_L=50pF$		25	35	ns
		$V_{CC}=5.5V, C_L=50pF$		21	32	
		$V_{CC}=4.5V, C_L=150pF$		32	52	
		$V_{CC}=5.5V, C_L=150pF$		27	47	
From LE to Q		$V_{CC}=4.5V, C_L=50pF$		28	35	
		$V_{CC}=5.5V, C_L=50pF$		25	32	
		$V_{CC}=4.5V, C_L=150pF$		38	52	
		$V_{CC}=5.5V, C_L=150pF$		36	47	
From $\overline{OE}$ to Q	$t_{EN}$ ( $t_{PZL}/t_{PZH}$ )	$V_{CC}=4.5V, C_L=50pF$		26	35	ns
		$V_{CC}=5.5V, C_L=50pF$		23	32	
		$V_{CC}=4.5V, C_L=150pF$		33	52	
		$V_{CC}=5.5V, C_L=150pF$		28	47	
From $\overline{OE}$ to Q	$t_{DIS}$ ( $t_{PLZ}/t_{PHZ}$ )	$V_{CC}=4.5V, C_L=50pF$		23	35	ns
		$V_{CC}=5.5V, C_L=50pF$		22	32	
Output transition rise/fall time	$t_r$ ( $t_r/t_f$ )	$V_{CC}=4.5V, C_L=50pF$		10	12	ns
		$V_{CC}=5.5V, C_L=50pF$		9	11	
		$V_{CC}=4.5V, C_L=150pF$		18	42	
		$V_{CC}=5.5V, C_L=150pF$		16	38	
Pulse Width, LE high	$t_w$	$V_{CC}=4.5V$	20			ns
		$V_{CC}=5.5V$	17			
Setup Time, data before LE↓	$t_{SU}$	$V_{CC}=4.5V$	10			ns
		$V_{CC}=5.5V$	9			
Hold Time, data after LE↓	$t_H$	$V_{CC}=4.5V$	10			ns
		$V_{CC}=5.5V$	10			

■ OPERATING CHARACTERISTICS (Unless otherwise specified)

PARAMETER	SYMBOL	TEST CONDITIONS	MIN	TYP	MAX	UNIT
Power Dissipation Capacitance	$C_{PD}$	No Load		50		pF

■ TEST CIRCUIT AND WAVEFORMS

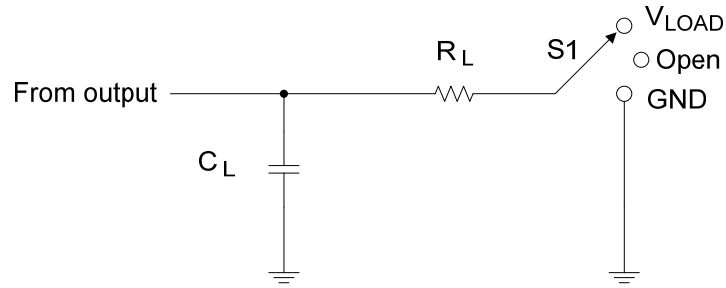

Test Circuit

TEST	S1
$t_{PLH}/t_{PHL}$	Open
$t_{PLZ}/t_{PZL}$	$V_{LOAD}$
$t_{PHZ}/t_{PZH}$	GND

$V_{CC}$	Input		$V_M$	$V_{LOAD}$	$C_L$	$R_L$	$V_{\Delta}$
	$V_{IN}$	$t_R, t_F$					
$5V \pm 0.5V$	$V_{CC}$	$\leq 3ns$	$V_{CC}/2$	$V_{CC}$	15pF	1k $\Omega$	0.5V
					50pF		

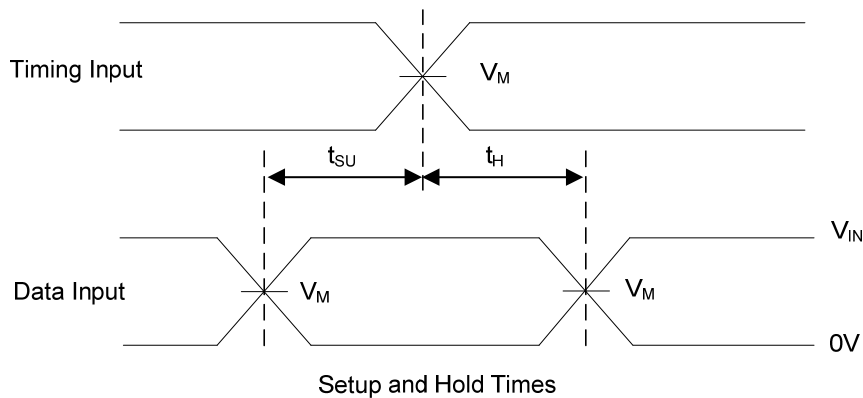
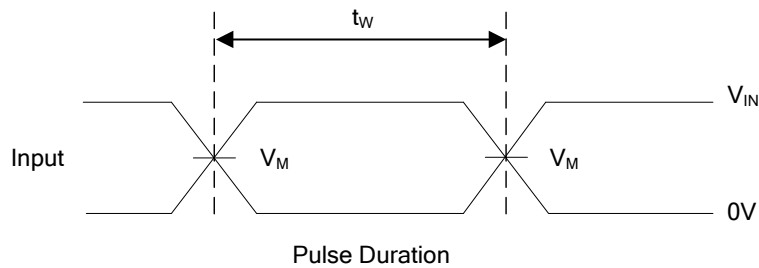

## ■ TEST CIRCUIT AND WAVEFORMS (Cont.)

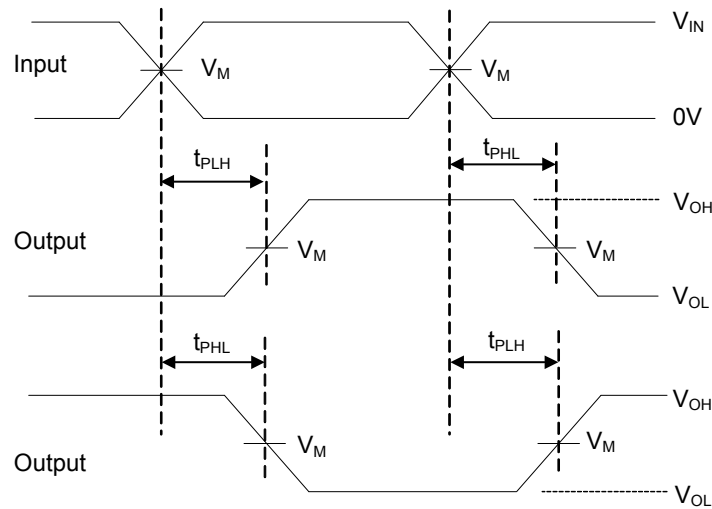

Voltage Waveforms Propagation Delay Times

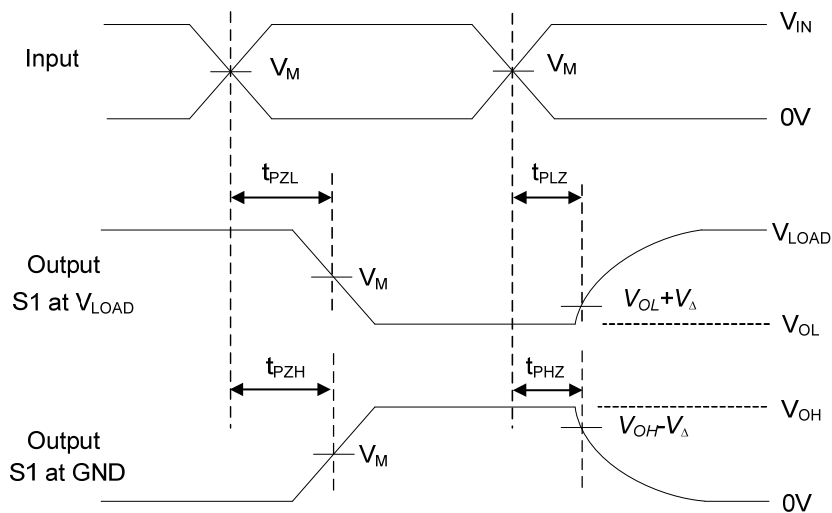

Voltage Waveforms Enable and Disable Times

Note: A.  $C_L$  includes probe and jig capacitance.

B.  $P_{RR} \leq 1\text{MHz}$ ,  $Z_O = 50\Omega$ ,  $t_R \leq 6\text{ns}$ ,  $t_F \leq 6\text{ns}$ .

UTC assumes no responsibility for equipment failures that result from using products at values that exceed, even momentarily, rated values (such as maximum ratings, operating condition ranges, or other parameters) listed in products specifications of any and all UTC products described or contained herein. UTC products are not designed for use in life support appliances, devices or systems where malfunction of these products can be reasonably expected to result in personal injury. Reproduction in whole or in part is prohibited without the prior written consent of the copyright owner. UTC reserves the right to make changes to information published in this document, including without limitation specifications and product descriptions, at any time and without notice. This document supersedes and replaces all information supplied prior to the publication hereof.