



U74LVC1G04

CMOS IC

SINGLE INVERTER GATE

DESCRIPTION

The UTC **U74LVC1G04** is a single inverter gate, it provides the function $Y = \bar{A}$.

This device has power-down protective circuit, preventing device destruction when it is powered down.

FEATURES

- * Operation voltage range: 1.65~5.5V
- * Low power current: $I_{CC}=10\mu A(\text{Max})$
- * $\pm 24\text{mA}$ output drive ($V_{CC}=3.3\text{V}$)
- * High noise immunity
- * Power down protection

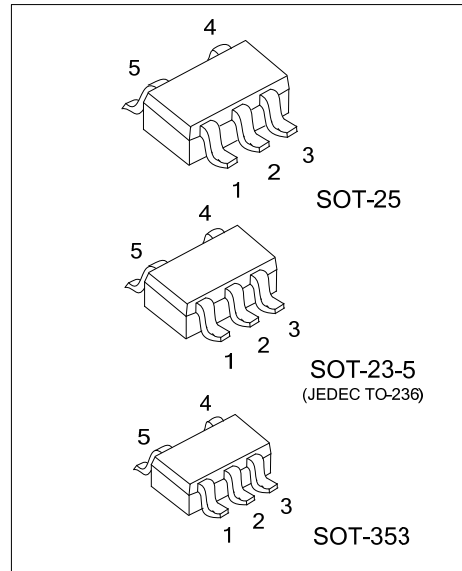

ORDERING INFORMATION

Ordering Number		Package	Packing
Lead Free	Halogen Free		
U74LVC1G04L-AE5-R	U74LVC1G04G-AE5-R	SOT-23-5	Tape Reel
U74LVC1G04L-AF5-R	U74LVC1G04G-AF5-R	SOT-25	Tape Reel
U74LVC1G04L-AL5-R	U74LVC1G04G-AL5-R	SOT-353	Tape Reel

<p>U74LVC1G04G-AE5-R</p>	<p>(1) R: Tape Reel (2) AE5: SOT-23-5, AF5: SOT-25, AL5: SOT-353 (3) G: Halogen Free and Lead Free, L: Lead Free</p>
--------------------------	--

MARKING

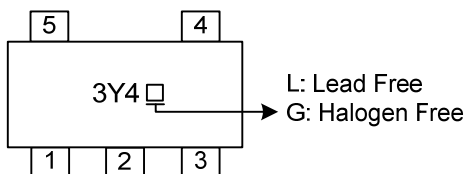

■ PIN CONFIGURATION

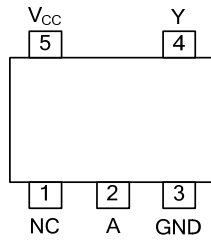

■ FUNCTION TABLE (each gate)

INPUT	OUTPUT
A	Y
H	L
L	H

■ LOGIC DIAGRAM (positive logic)

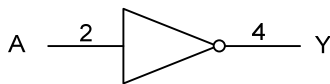

■ ABSOLUTE MAXIMUM RATINGS (unless otherwise specified)(Note 2)

PARAMETER		SYMBOL	RATINGS	UNIT
Supply Voltage		V_{CC}	-0.5 ~ 6.5	V
Input Voltage		V_{IN}	-0.5 ~ 6.5	V
Output Voltage(Active Mode)		V_{OUT}	-0.5 ~ $V_{CC}+0.5$	V
Output Voltage(Power-Down Mode)		V_{OUT}	-0.5 ~ 6.5	V
Input Clamp Current($V_{IN}<0$)		I_{IK}	-50	mA
Output Clamp Current($V_{OUT}<0$)		I_{OK}	-50	mA
Output Current		I_{OUT}	±50	mA
V_{CC} or GND Current		I_{CC}	±100	mA
Power Dissipation ($T_A=-40\sim+125^{\circ}C$)	SOT-23-5	P_D	300	mW
	SOT-25		360	mW
	SOT-353		250	mW
Junction Temperature		T_J	+150	°C
Storage Temperature		T_{STG}	-65 ~ +150	°C

Notes: 1. Absolute maximum ratings are those values beyond which the device could be permanently damaged.

Absolute maximum ratings are stress ratings only and functional device operation is not implied.

2. The input and output voltage ratings may be exceeded if the input and output current ratings are observed.

■ THERMAL DATA

PARAMETER		SYMBOL	RATINGS	UNIT
Junction to Case	SOT-23-5	θ_{JC}	75	°C/W
	SOT-25		55	°C/W
	SOT-353		145	°C/W

■ RECOMMENDED OPERATING CONDITIONS

PARAMETER	SYMBOL	CONDITIONS	MIN	TYP	MAX	UNIT
Supply Voltage	V_{CC}	Operating	1.65		5.5	V
		Data retention only	1.5			
Input Voltage	V_{IN}		0		5.5	V
Output Voltage	V_{OUT}		0		V_{CC}	V
Input Transition Rise or Fall Rate	t_R, t_F	$V_{CC} = 1.8V\pm0.15V, 2.5V\pm0.2V$			20	ns/V
		$V_{CC} = 3.3V\pm0.3V$			10	ns/V
		$V_{CC} = 5V\pm0.5V$			5	ns/V
Operating Temperature	T_A		-40		+125	°C

■ STATIC CHARACTERISTICS (Unless otherwise specified)

PARAMETER	SYMBOL	TEST CONDITIONS	T _A =25°C			T _A =-40°C~+125°C			UNIT
			MIN	TYP	MAX	MIN	TYP	MAX	
Input Voltage High-Level	V _{IH}	V _{CC} = 1.65V~1.95V	0.65× V _{CC}			0.65× V _{CC}			V
		V _{CC} = 2.3V~2.7V	1.7			1.7			
		V _{CC} = 2.7V~3.6V	2			2			
		V _{CC} = 4.5V~5.5V	0.7× V _{CC}			0.7× V _{CC}			
Input Voltage Low-Level	V _{IL}	V _{CC} = 1.65V~1.95V			0.35× V _{CC}			0.35× V _{CC}	V
		V _{CC} = 2.3V~2.7V			0.7			0.7	
		V _{CC} = 2.7V~3.6V			0.8			0.8	
		V _{CC} = 4.5V~5.5V			0.3× V _{CC}			0.3× V _{CC}	
Output Voltage High-Level	V _{OH}	V _{CC} = 1.65V~5.5V, I _{OH} =-100μA	V _{CC} -0.1			V _{CC} -0.1			V
		V _{CC} = 1.65V, I _{OH} =-4mA	1.2			0.95			
		V _{CC} = 2.3V, I _{OH} =-8mA	1.9			1.7			
		V _{CC} = 3V, I _{OH} =-16mA	2.2			1.9			
		V _{CC} = 3V, I _{OH} =-24mA	2.3			2.0			
		V _{CC} = 4.5V, I _{OH} =-32mA	3.8			3.4			
Output Voltage Low-Level	V _{OL}	V _{CC} = 1.65V~5.5V, I _{OL} =100μA			0.1			0.1	V
		V _{CC} = 1.65V, I _{OL} =4mA			0.45			0.7	
		V _{CC} = 2.3V, I _{OL} =8mA			0.3			0.45	
		V _{CC} = 3V, I _{OL} =16mA			0.4			0.6	
		V _{CC} = 3V, I _{OL} =24mA			0.55			0.8	
		V _{CC} = 4.5V, I _{OL} =32mA			0.55			0.8	
Input Leakage Current	I _{I(LEAK)}	V _{CC} = 0~5.5V, V _{IN} =5.5V or GND		±0.1	±5			±5	μA
Power OFF Leakage Current	I _{OFF}	V _{CC} = 0V, V _{IN} or V _{OUT} =5.5V		±0.1	±10			±10	μA
Quiescent Supply Current	I _Q	V _{CC} = 1.65V~5.5V, V _{IN} =5.5 or GND, I _{OUT} =0		0.1	10			10	μA
Additional Quiescent Supply Current	Δ I _Q	V _{CC} = 3V~5.5V, One input at V _{CC} - 0.6V, other inputs at V _{CC} or GND		5	500			500	μA

Note: All typical values are measured at V_{CC}=3.3V and T_A=25°C.

■ DYNAMIC CHARACTERISTICS (Unless otherwise specified)

PARAMETER	SYMBOL	TEST CONDITIONS	T _A =25°C			T _A =-40°C~+125°C			UNIT
			MIN	TYP	MAX	MIN	TYP	MAX	
Propagation Delay From Input (A or B) to Output (Y)	t _{PLH} / t _{PHL}	V _{CC} = 1.8V±0.15V, C _L =15 pF	1.0		11			14	ns
		V _{CC} = 2.5V±0.2V, C _L =15 pF	0.5		8			10.5	ns
		V _{CC} = 3.3V±0.3V, C _L =15 pF	0.5		6			8	ns
		V _{CC} = 5V±0.5V, C _L =15 pF	0.5		5			6	ns
		V _{CC} = 1.8V±0.15V, C _L =30pF	1.0		12			15	ns
		V _{CC} = 2.5V±0.2V, C _L =30pF	0.5		9			11.5	ns
		V _{CC} = 3.3V±0.3V, C _L =50 pF	0.5		7			9	ns
		V _{CC} = 5V±0.5V, C _L =50 pF	0.5		6			7	ns

■ OPERATING CHARACTERISTICS

PARAMETER	SYMBOL	TEST CONDITIONS	MIN	TYP	MAX	UNIT
Input Capacitance	C_{IN}	$V_{CC}= 3.3V, V_{IN}=V_{CC}$ or GND		3.5		pF
Power Dissipation Capacitance	C_{PD}	$V_{CC}=1.8V, f=10MHz$		16		pF
		$V_{CC}=2.5V, f=10MHz$		18		pF
		$V_{CC}=3.3V, f=10MHz$		18		pF
		$V_{CC}=5V, f=10MHz$		20		pF

Note: All typical values are measured at $T_A=25^{\circ}C$.

■ TEST CIRCUIT AND WAVEFORMS

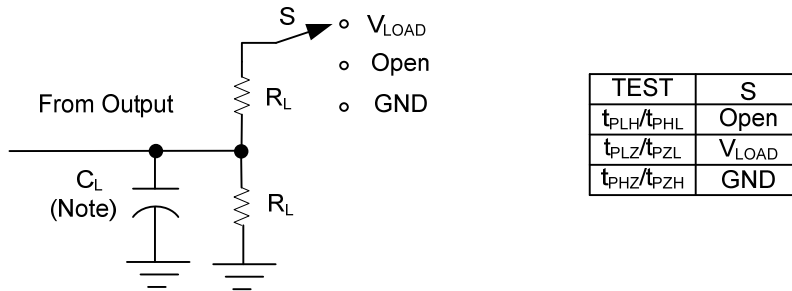

Note: C_L includes probe and jig capacitance.

V_{CC}	V_{IN}	t_R, t_F	V_M	V_{LOAD}	C_L	R_L	V_{Δ}
$1.8V \pm 0.15V$	V_{CC}	$\leq 2ns$	$V_{CC}/2$	$2 \times V_{CC}$	15pF	1M Ω	0.15V
$2.5V \pm 0.2V$	V_{CC}	$\leq 2ns$	$V_{CC}/2$	$2 \times V_{CC}$	15pF	1M Ω	0.15V
$3.3V \pm 0.3V$	3 V	$\leq 2.5ns$	1.5V	6V	15pF	1M Ω	0.3V
$5V \pm 0.5V$	V_{CC}	$\leq 2.5ns$	$V_{CC}/2$	$2 \times V_{CC}$	15pF	1M Ω	0.3V
$1.8V \pm 0.15V$	V_{CC}	$\leq 2ns$	$V_{CC}/2$	$2 \times V_{CC}$	30pF	1k Ω	0.15V
$2.5V \pm 0.2V$	V_{CC}	$\leq 2ns$	$V_{CC}/2$	$2 \times V_{CC}$	30pF	500 Ω	0.15V
$3.3V \pm 0.3V$	3 V	$\leq 2.5ns$	1.5V	6V	50pF	500 Ω	0.3V
$5V \pm 0.5V$	V_{CC}	$\leq 2.5ns$	$V_{CC}/2$	$2 \times V_{CC}$	50pF	500 Ω	0.3V

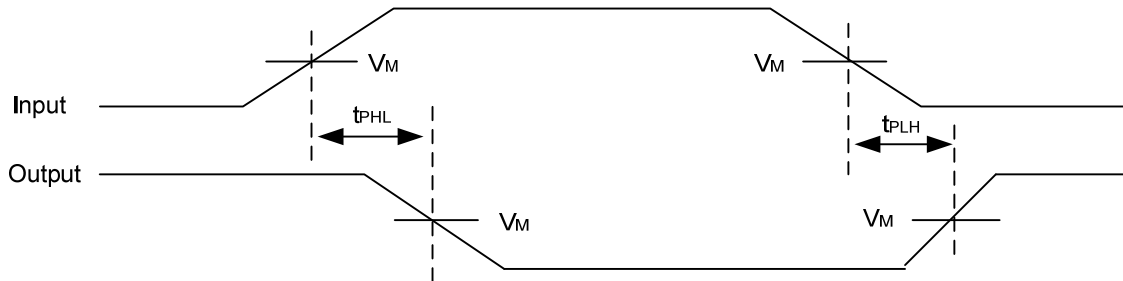

UTC assumes no responsibility for equipment failures that result from using products at values that exceed, even momentarily, rated values (such as maximum ratings, operating condition ranges, or other parameters) listed in products specifications of any and all UTC products described or contained herein. UTC products are not designed for use in life support appliances, devices or systems where malfunction of these products can be reasonably expected to result in personal injury. Reproduction in whole or in part is prohibited without the prior written consent of the copyright owner. UTC reserves the right to make changes to information published in this document, including without limitation specifications and product descriptions, at any time and without notice. This document supersedes and replaces all information supplied prior to the publication hereof.