



## U74LVC1G10

CMOS IC

### SINGLE 3-INPUT POSITIVE-NAND GATE

#### DESCRIPTION

The **U74LVC1G10** performs the Boolean function  $Y = A \cdot B \cdot C$  or  $Y = \overline{A + B + C}$  in positive logic.

The device is fully specified for partial-power-down applications using Ioff. The Ioff circuitry disables the outputs, preventing damaging current backflow through the device when it is powered down.

#### FEATURES

- \* Supports 5-V V<sub>CC</sub> Operation
- \* Inputs Accept Voltages to 5.5V
- \* Max t<sub>pd</sub> of 3.8ns at 3.3V
- \* Low power consumption, I<sub>CC</sub>=10μA (Max)
- \* I<sub>off</sub> supports Partial-Power-Down Mode
- \* ±24mA output drive at 3.3V

#### ORDERING INFORMATION

Ordering Number		Package	Packing
Lead Free	Halogen Free		
U74LVC1G10L-AG6-R	U74LVC1G10G-AG6-R	SOT-26	Tape Reel
U74LVC1G10L-AL6-R	U74LVC1G10G-AL6-R	SOT-363	Tape Reel

<p>U74LVC1G10G-AG6-R</p> <p>(1) Packing Type</p> <p>(2) Package Type</p> <p>(3) Green Package</p>	<p>(1) R: Tape Reel</p> <p>(2) AG6: SOT-26, AL6: SOT-363</p> <p>(3) G: Halogen Free and Lead Free, L: Lead Free</p>
---	---

#### MARKING

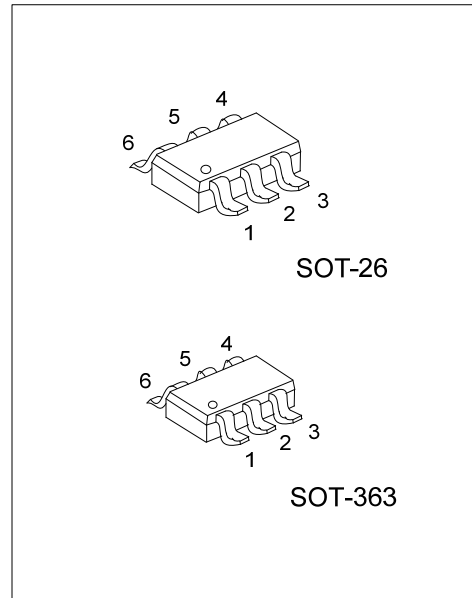
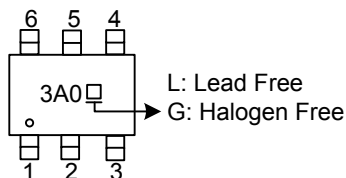

## ■ PIN CONFIGURATION

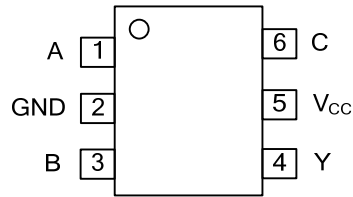

## ■ FUNCTION TABLE

INPUTS			OUTPUT Y
A	B	C	
H	H	H	L
L	X	X	H
X	L	X	H
X	X	L	H

Note: H: HIGH voltage level; L: LOW voltage level; X: Don't care.

## ■ LOGIC DIAGRAM (positive logic)

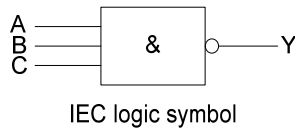
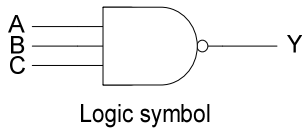

### ■ ABSOLUTE MAXIMUM RATING

PARAMETER		SYMBOL	RATINGS	UNIT
Supply Voltage		$V_{CC}$	-0.5 ~ +6.5	V
Input Voltage		$V_{IN}$	-0.5 ~ +6.5	V
Output Voltage	Output in the high or low state	$V_{OUT}$	-0.5 ~ $V_{CC}+0.5$	V
	Output in the high-impedance or power-off state		-0.5 ~ +6.5	V
$V_{CC}$ or GND Current		$I_{CC}$	±100	mA
Continuous Output Current ( $V_{OUT}=0$ to $V_{CC}$ )		$I_{OUT}$	±50	mA
Input Clamp Current ( $V_{IN}<0$ )		$I_{IK}$	-50	mA
Output Clamp Current ( $V_{OUT}<0$ )		$I_{OK}$	±50	mA
Operating Temperature		$T_A$	-40 ~ +85	°C
Storage Temperature Range		$T_{STG}$	-65 ~ +150	°C

Note: Absolute maximum ratings are those values beyond which the device could be permanently damaged. Absolute maximum ratings are stress ratings only and functional device operation is not implied.

### ■ THERMAL DATA

PARAMETER		SYMBOL	RATINGS	UNIT
Junction to Ambient	SOT-26	$\theta_{JA}$	230	°C/W
	SOT-363		350	°C/W

### ■ RECOMMENDED OPERATING CONDITIONS

PARAMETER	SYMBOL	TEST CONDITIONS	MIN	TYP	MAX	UNIT
Supply Voltage	$V_{CC}$	Operating	1.65		5.5	V
Input Voltage	$V_{IN}$		0		5.5	V
Output Voltage	$V_{OUT}$	High or low state	0		$V_{CC}$	V
High-level input voltage	$V_{IH}$	$V_{CC}=1.65V$ to $1.95V$	$0.65 \times V_{CC}$			V
		$V_{CC}=2.3V$ to $2.7V$	1.7			
		$V_{CC}=3V$ to $3.6V$	2			
		$V_{CC}=4.5V$ to $5.5V$	$0.7 \times V_{CC}$			
Low-level input voltage	$V_{IL}$	$V_{CC}=1.65V$ to $1.95V$			$0.35 \times V_{CC}$	V
		$V_{CC}=2.3V$ to $2.7V$			0.7	
		$V_{CC}=3V$ to $3.6V$			0.8	
		$V_{CC}=4.5V$ to $5.5V$			$0.3 \times V_{CC}$	
Input Transition Rise or Fall Rate	$\Delta t/\Delta v$	$V_{CC}=1.8V \pm 0.15V$ , $2.5V \pm 0.2V$			20	ns/V
		$V_{CC}=3.3V \pm 0.3V$			10	
		$V_{CC}=5V \pm 0.5V$			10	

Note: All unused inputs of the device must be held at  $V_{CC}$  or GND to ensure proper device operation.

■ ELECTRICAL CHARACTERISTICS (T<sub>A</sub> =25°C, unless otherwise specified)

PARAMETER	SYMBOL	TEST CONDITIONS	MIN	TYP	MAX	UNIT
High-Level Output Voltage	V <sub>OH</sub>	V <sub>CC</sub> =1.65 ~ 5.5V, I <sub>OH</sub> =-100μA	V <sub>CC</sub> -0.1			V
		V <sub>CC</sub> =1.65V, I <sub>OH</sub> =-4mA	1.2			V
		V <sub>CC</sub> =2.3V, I <sub>OH</sub> =-8mA	1.9			V
		V <sub>CC</sub> =3.0V, I <sub>OH</sub> =-16mA	2.4			V
			I <sub>OH</sub> =-24mA	2.3		
V <sub>CC</sub> =4.5V, I <sub>OH</sub> =-32mA	3.8			V		
Low-Level Output Voltage	V <sub>OL</sub>	V <sub>CC</sub> =1.65 ~ 5.5V, I <sub>OL</sub> =100μA			0.1	V
		V <sub>CC</sub> =1.65V, I <sub>OL</sub> =4mA			0.45	V
		V <sub>CC</sub> =2.3V, I <sub>OL</sub> =8mA			0.30	V
		V <sub>CC</sub> =3.0V, I <sub>OL</sub> =16mA			0.40	V
			I <sub>OL</sub> =24mA		0.55	V
V <sub>CC</sub> =4.5V, I <sub>OL</sub> =32mA			0.55	V		
Input Leakage Current	I <sub>I(LEAK)</sub>	V <sub>IN</sub> =5.5V or GND, V <sub>CC</sub> =0 ~ 5.5V			±5	μA
Power OFF Leakage Current	I <sub>off</sub>	V <sub>IN</sub> or V <sub>OUT</sub> =5.5V, V <sub>CC</sub> =0V			±10	μA
Quiescent Supply Current	I <sub>CC</sub>	V <sub>IN</sub> =5.5V or GND, I <sub>OUT</sub> =0 V <sub>CC</sub> =1.65 ~ 5.5V			10	μA
Additional Quiescent Supply Current Per Input Pin	ΔI <sub>CC</sub>	V <sub>CC</sub> =3V ~ 5.5V, One input at V <sub>CC</sub> -0.6V, Other inputs at V <sub>CC</sub> or GND			500	μA
Input Capacitance	C <sub>I</sub>	V <sub>CC</sub> =3.3V, V <sub>IN</sub> =V <sub>CC</sub> or GND		3.5		pF

■ SWITCHING CHARACTERISTICS (T<sub>A</sub>=25°C, unless otherwise specified)(see Figure 1)

PARAMETER	SYMBOL	TEST CONDITIONS	MIN	TYP	MAX	UNIT
Propagation delay from input (A,B or C) to output(Y)	t <sub>PLH</sub> /t <sub>PHL</sub>	V <sub>CC</sub> =1.8V±0.15V, C <sub>L</sub> =15pF	2		14.8	ns
			C <sub>L</sub> =30pF	2.5		
		V <sub>CC</sub> =2.5V±0.2V, C <sub>L</sub> =15pF	1.3		5.5	ns
			C <sub>L</sub> =30pF	1.6		
		V <sub>CC</sub> =3.3V±0.3V, C <sub>L</sub> =15pF	0.8		3.8	ns
			C <sub>L</sub> =50pF	1.4		
		V <sub>CC</sub> =5V±0.5V, C <sub>L</sub> =15pF	0.6		2.7	ns
			C <sub>L</sub> =50pF	1		

■ OPERATING CHARACTERISTICS (T<sub>A</sub>=25°C, unless otherwise specified)

PARAMETER	SYMBOL	TEST CONDITIONS	MIN	TYP	MAX	UNIT
Power Dissipation Capacitance	C <sub>PD</sub>	f=10MHZ	V <sub>CC</sub> =1.8V		17	pF
			V <sub>CC</sub> =2.5V		18	pF
			V <sub>CC</sub> =3.3V		19	pF
			V <sub>CC</sub> =5.0V		22	pF

## ■ TEST CIRCUIT AND WAVEFORMS

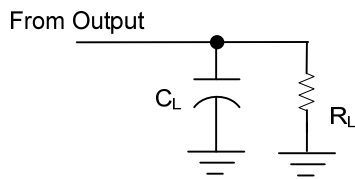

**TEST CIRCUIT**

V <sub>CC</sub>	INPUTS		V <sub>M</sub>	C <sub>L</sub>	R <sub>L</sub>
	V <sub>I</sub>	t <sub>r</sub> / t <sub>f</sub>			
1.8V±0.15V	V <sub>CC</sub>	≤2ns	V <sub>CC</sub> /2	15pF	1MΩ
				30pF	1KΩ
2.5V±0.2V	V <sub>CC</sub>	≤2ns	V <sub>CC</sub> /2	15pF	1MΩ
				30pF	500Ω
3.3V±0.3V	3V	≤2.5ns	1.5V	15pF	1MΩ
				50pF	500Ω
5V±0.5V	V <sub>CC</sub>	≤2.5ns	V <sub>CC</sub> /2	15pF	1MΩ
				50pF	500Ω

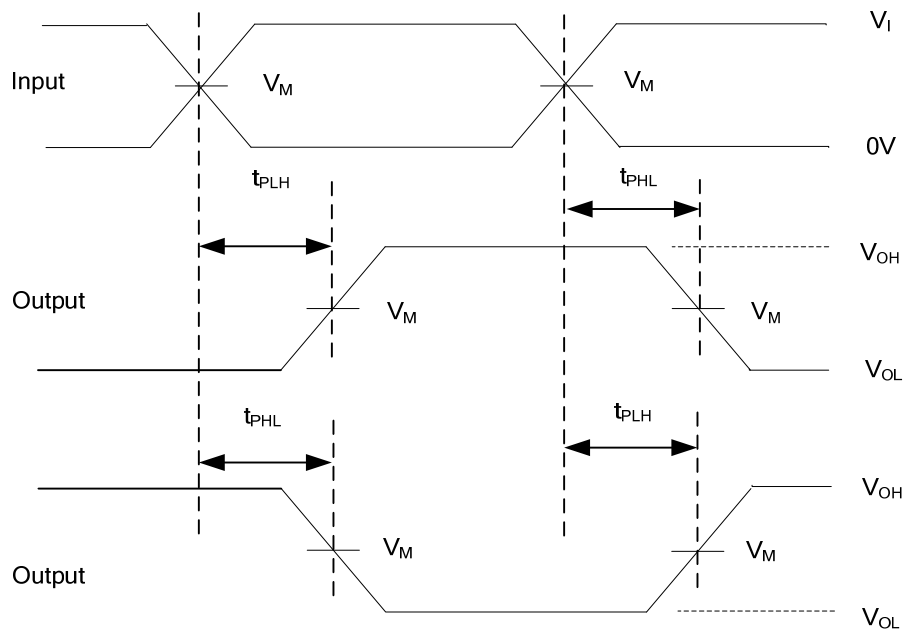

**PROPAGATION DELAY TIMES**

Figure 1. Test Circuit and Voltage Waveforms

Note: 1. C<sub>L</sub> includes probe and jig capacitance.

2. All input pulses are supplied by generators having the following characteristics: PRR ≤10MHz, Z<sub>0</sub>=50Ω.

UTC assumes no responsibility for equipment failures that result from using products at values that exceed, even momentarily, rated values (such as maximum ratings, operating condition ranges, or other parameters) listed in products specifications of any and all UTC products described or contained herein. UTC products are not designed for use in life support appliances, devices or systems where malfunction of these products can be reasonably expected to result in personal injury. Reproduction in whole or in part is prohibited without the prior written consent of the copyright owner. UTC reserves the right to make changes to information published in this document, including without limitation specifications and product descriptions, at any time and without notice. This document supersedes and replaces all information supplied prior to the publication hereof.