



U74LVC1G126

CMOS IC

BUS BUFFER/LINE DRIVER; 3-STATE

DESCRIPTION

The **U74LVC1G126** is single bus buffer/line driver with 3-state output. The output is disabled When the output enable (OE) is low. When OE is high, true data is will pass A input to the Y output.

This device has power-down protective circuit preventing device from destruction when it is powered down.

FEATURES

- * Operate From 1.65V to 5.5V
- * Inputs Accept Voltages to 5.5V
- * High Noise Immunity
- * Low Power Dissipation
- * Direct Interface With TTL level

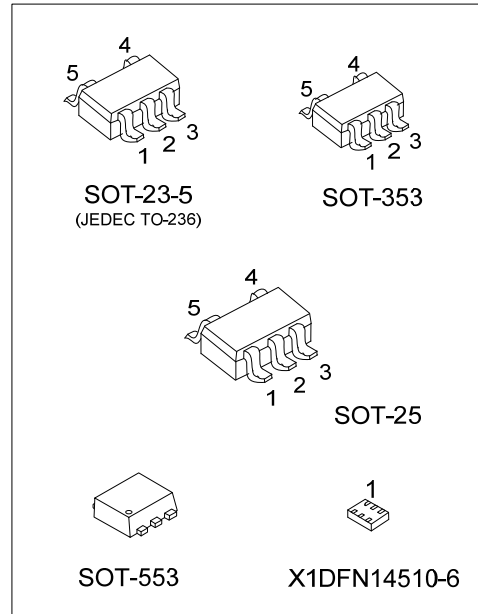

ORDERING INFORMATION

Ordering Number		Package	Packing
Lead Free	Halogen Free		
U74LVC1G126L-AE5-R	U74LVC1G126G-AE5-R	SOT-23-5	Tape Reel
U74LVC1G126L-AF5-R	U74LVC1G126G-AF5-R	SOT-25	Tape Reel
U74LVC1G126L-AL5-R	U74LVC1G126G-AL5-R	SOT-353	Tape Reel
U74LVC1G126L-AN5-R	U74LVC1G126G-AN5-R	SOT-553	Tape Reel
U74LVC1G126L-KAP-R	U74LVC1G126G-KAP-R	X1DFN14510-6	Tape Reel

<p>U74LVC1G126G-AE5-R</p> <p>(1)Packing Type (2)Package Type (3)Green Package</p>	<p>(1) R: Tape Reel (2) AE5: SOT-23-5, AF5: SOT-25, AL5: SOT-353 AN5: SOT-553, KAP: X1DFN14510-6 (3) G: Halogen Free and Lead Free, L: Lead Free</p>
---	--

MARKING

SOT-23-5 / SOT-25 / SOT-353 / SOT-553	X1DFN14510-6
<p>L: Lead Free G: Halogen Free</p>	<p>L: Lead Free G: Halogen Free</p>

■ PIN CONFIGURATION

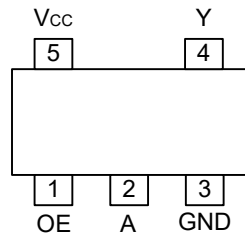

SOT-23-5 / SOT-25
SOT-353 / SOT-553

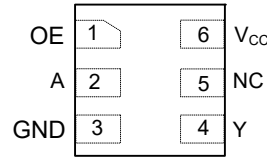

X1DFN14510-6
(TOP VIEW)

■ FUNCTION TABLE

INPUT(OE)	INPUT(A)	OUTPUT(Y)
H	L	L
H	H	H
L	X	Z

Note: H: HIGH voltage level; L: LOW voltage level; X=don't care; Z=high-impedance OFF-state.

■ LOGIC DIAGRAM (Positive Logic)

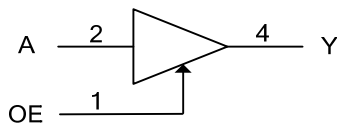

Logic Symbol

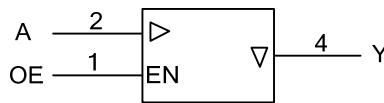

IEC Logic Symbol

■ ABSOLUTE MAXIMUM RATING

PARAMETER		SYMBOL	RATINGS	UNIT
Supply Voltage		V_{CC}	-0.5 ~ +6.5	V
Input Voltage		V_{IN}	-0.5 ~ +6.5	V
Output Voltage	Enable mode	V_{OUT}	-0.5 ~ $V_{CC} + 0.5$	V
	Disable mode		-0.5 ~ +6.5	V
	Power-down mode		-0.5 ~ +6.5	V
V_{CC} or GND Current		I_{CC}	±100	mA
Continuous Output Current ($V_{OUT}=0$ to V_{CC})		I_{OUT}	±50	mA
Input Clamp Current ($V_{IN}<0$)		I_{IK}	-50	mA
Output Clamp Current ($V_{OUT}>V_{CC}$ or $V_{OUT}<0$)		I_{OK}	-50	mA
Power Dissipation ($T_A=-40^{\circ}C \sim +125^{\circ}C$)	SOT-23-5	P_D	300	mW
	SOT-25		360	mW
	SOT-353		250	mW
	SOT-553		210	mW
	X1DFN14510-6		200	mW
Storage Temperature		T_{STG}	-65 ~ +150	$^{\circ}C$

Note: Absolute maximum ratings are those values beyond which the device could be permanently damaged. Absolute maximum ratings are stress ratings only and functional device operation is not implied.

■ RECOMMENDED OPERATING CONDITIONS

PARAMETER	SYMBOL	TEST CONDITIONS	MIN	TYP	MAX	UNIT
Supply Voltage	V_{CC}	Operating	1.65		5.5	V
Input Voltage	V_{IN}		0		5.5	V
Output Voltage	V_{OUT}	$V_{CC}=1.65V \sim 5.5V$; Enable mode	0		V_{CC}	V
		$V_{CC}=1.65V \sim 5.5V$; Disable mode	0		5.5	V
		$V_{CC}=0V$; Power-Down Mode	0		5.5	V
Input Transition Rise or Fall Rate	t_R / t_F	$V_{CC}=1.65V \sim 2.7V$			20	ns/V
		$V_{CC}=2.7V \sim 5.5V$			10	ns/V
Operating Temperature	T_A		-40		+125	$^{\circ}C$

■ ELECTRICAL CHARACTERISTICS (Unless otherwise specified)

PARAMETER	SYMBOL	TEST CONDITIONS	T _A =25°C			T _A =-40°C~+125°C			UNIT
			MIN	TYP	MAX	MIN	TYP	MAX	
High-Level Input Voltage	V _{IH}	V _{CC} =1.65V ~ 1.95V	0.65× V _{CC}			0.65× V _{CC}			V
		V _{CC} =2.3V ~ 2.7V	1.7			1.7			V
		V _{CC} =2.7V ~ 3.6V	2			2			V
		V _{CC} =4.5V ~ 5.5V	0.7× V _{CC}			0.7× V _{CC}			V
Low-Level Input Voltage	V _{IL}	V _{CC} =1.65V ~ 1.95V			0.35× V _{CC}			0.35× V _{CC}	V
		V _{CC} =2.3V ~ 2.7V			0.7			0.7	V
		V _{CC} =2.7V ~ 3.6V			0.8			0.8	V
		V _{CC} =4.5V ~ 5.5V			0.3× V _{CC}			0.3× V _{CC}	V
High-Level Output Voltage	V _{OH}	V _{CC} =1.65 ~ 5.5V, I _{OH} =-100μA	V _{CC} - 0.1			V _{CC} - 0.1			V
		V _{CC} =1.65V, I _{OH} =-4mA	1.2			0.95			V
		V _{CC} =2.3V, I _{OH} =-8mA	1.9			1.7			V
		V _{CC} =2.7V, I _{OH} =-12mA	2.2			1.9			V
		V _{CC} =3.0V, I _{OH} =-24mA	2.3			2.0			V
		V _{CC} =4.5V, I _{OH} =-32mA	3.8			3.4			V
Low-Level Output Voltage	V _{OL}	V _{CC} =1.65 ~ 5.5V, I _{OL} =100μA			0.1			0.1	V
		V _{CC} =1.65V, I _{OL} =4mA			0.45			0.7	V
		V _{CC} =2.3V, I _{OL} =8mA			0.3			0.45	V
		V _{CC} =2.7V, I _{OL} =12mA			0.4			0.6	V
		V _{CC} =3.0V, I _{OL} =24mA			0.55			0.8	V
		V _{CC} =4.5V, I _{OL} =32mA			0.55			0.8	V
Input Leakage Current	I _{I(LEAK)}	V _{CC} =5.5V, V _{IN} =5.5V or GND		±0.1	±5			±5	μA
Power OFF Leakage Current	I _{OFF}	V _{CC} =0V, V _{IN} or V _{OUT} =5.5V		±0.1	±10			±10	μA
3-State Output OFF-State Current	I _{OZ}	V _{CC} =5.5V V _{IN} =V _{IH} or V _{IL} , V _{OUT} =V _{CC} or GND		±0.1	±10			±10	μA
Quiescent Supply Current	I _{CC}	V _{CC} =5.5V, V _{IN} =V _{CC} or GND, I _{OUT} =0		0.1	10			10	μA
Additional Quiescent Supply Current Per Input Pin	ΔI _{CC}	V _{CC} =2.3 ~ 5.5V, V _{IN} =V _{CC} -0.6V, I _{OUT} =0		5	500			500	μA

■ SWITCHING CHARACTERISTICS (Unless otherwise specified)

PARAMETER	SYMBOL	TEST CONDITIONS	T _A =25°C			T _A =-40°C~+125°C			UNIT	
			MIN	TYP	MAX	MIN	TYP	MAX		
Propagation Delay From Input (A) to Output (Y)	t _{PLH} / t _{PHL}	C _L =30pF	V _{CC} =1.8±0.15V, R _L =1KΩ	1.0		16			20	ns
			V _{CC} =2.5±0.2V, R _L =500Ω	0.5		10			14	ns
		C _L =50pF, R _L =500Ω	V _{CC} =2.7V	0.5		10			14	ns
			V _{CC} =3.3±0.3V	0.5		7			11	ns
			V _{CC} =5±0.5V	0.5		5			9	ns
3-State Output Enable Time From Input (OE) to Output (Y)	t _{PZH} / t _{PZL}	C _L =30pF	V _{CC} =1.8±0.15V, R _L =1KΩ	1.0		18			22	ns
			V _{CC} =2.5±0.2V, R _L =500Ω	0.5		11			14	ns
		C _L =50pF, R _L =500Ω	V _{CC} =2.7V	0.5		11			14	ns
			V _{CC} =3.3±0.3V	0.5		7			11	ns
			V _{CC} =5±0.5V	0.5		6			9	ns
3-State Output Disable Time From Input (OE) to Output (Y)	t _{PLZ} / t _{PHZ}	C _L =30pF	V _{CC} =1.8±0.15V, R _L =1KΩ	1.0		10			13	ns
			V _{CC} =2.5±0.2V, R _L =500Ω	0.5		7			10	ns
		C _L =50pF, R _L =500Ω	V _{CC} =2.7V	0.5		7			9	ns
			V _{CC} =3.3±0.3V	0.5		6			8	ns
			V _{CC} =5±0.5V	0.5		5			7	ns

TEST CIRCUIT AND WAVEFORMS

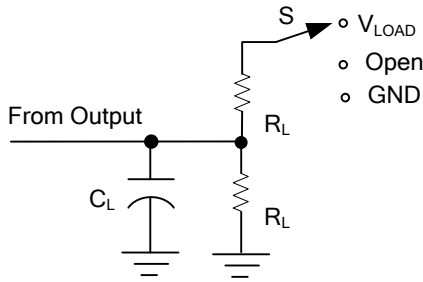

TEST	S
t_{PLH}/t_{PHL}	Open
t_{PHZ}/t_{PZH}	GND
t_{PLZ}/t_{PZL}	V_{LOAD}

TEST CIRCUIT

V_{CC}	INPUTS		V_M	V_{LOAD}	V_{Δ}	C_L	R_L
	V_{IN}	t_R, t_F					
$1.8V \pm 0.15V$	V_{CC}	$\leq 2ns$	$V_{CC}/2$	$2 \times V_{CC}$	0.15V	30pF	1K Ω
$2.5V \pm 0.2V$	V_{CC}	$\leq 2ns$	$V_{CC}/2$	$2 \times V_{CC}$	0.15V	30pF	500 Ω
2.7V	2.7V	$\leq 2.5ns$	1.5V	6V	0.3V	50pF	500 Ω
$3.3V \pm 0.3V$	2.7V	$\leq 2.5ns$	1.5V	6V	0.3V	50pF	500 Ω
$5V \pm 0.5V$	V_{CC}	$\leq 2.5ns$	$V_{CC}/2$	$2 \times V_{CC}$	0.3V	50pF	500 Ω

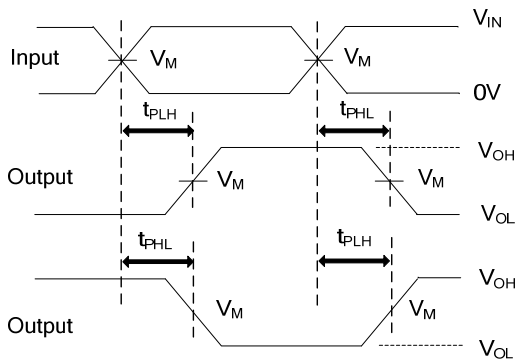

PROPAGATION DELAY TIMES

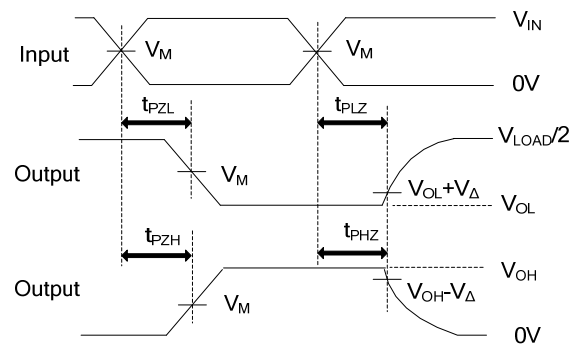

ENABLE AND DISABLE TIMES

Notes: 1. C_L includes probe and jig capacitance.

2. All input pulses are supplied by generators having the following characteristics: $P_{RR} \leq 10MHz$, $Z_o = 50\Omega$.

UTC assumes no responsibility for equipment failures that result from using products at values that exceed, even momentarily, rated values (such as maximum ratings, operating condition ranges, or other parameters) listed in products specifications of any and all UTC products described or contained herein. UTC products are not designed for use in life support appliances, devices or systems where malfunction of these products can be reasonably expected to result in personal injury. Reproduction in whole or in part is prohibited without the prior written consent of the copyright owner. UTC reserves the right to make changes to information published in this document, including without limitation specifications and product descriptions, at any time and without notice. This document supersedes and replaces all information supplied prior to the publication hereof.