



U74LVC1G99

CMOS IC

ULTRA-CONFIGURABLE MULTIPLE-FUNCTION GATE WITH 3-STATE OUTPUT

DESCRIPTION

The **U74LVC1G99** is a configurable multiple functions with 3-state output device, and when output-enable (OE) input is high, the output is disabled, when OE is low, the output state is determined by 16 patterns of 4-bit input. The user can choose different logic functions

Such as AND, OR, NAND, NOR, XOR, XNOR, MUX, inverter, and buffer, by changing the inputs' logic state. All inputs can be connected to V_{CC} or GND.

The device have different input threshold levels for positive-going (V_{T+}) and negative-going (V_{T-}) signals because of the Schmitt-trigger action in the input.

This device has power-down protective circuit, preventing device destruction when it is powered down.

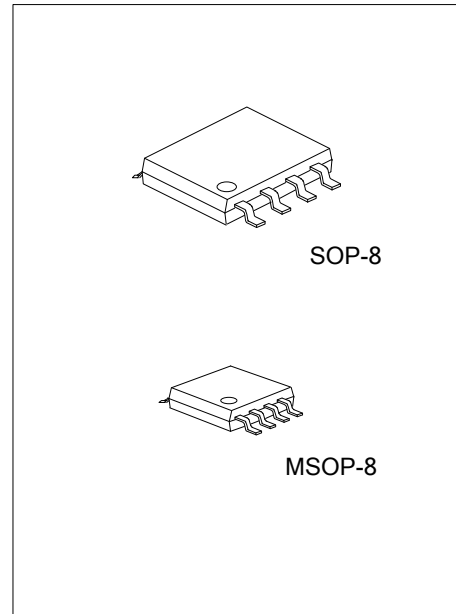

FEATURES

- * Operate from 1.65V to 5.5V
- * Inputs accept voltages to 5.5V
- * All inputs have Schmitt-trigger action
- * I_{off} supports partial-power-down mode
- * Low power dissipation: $I_{CC}=10\mu A(\text{Max.})$
- * Max t_{PD} of 6.7 ns at 3.3V
- * $\pm 24\text{mA}$ output drive ($V_{CC}=3.3\text{V}$)
- * Offers nine different logic functions in a single package

ORDERING INFORMATION

Ordering Number		Package	Packing
Lead Free	Halogen Free		
U74LVC1G99L-S08-R	U74LVC1G99G-S08-R	SOP-8	Tape Reel
U74LVC1G99L-SM1-R	U74LVC1G99G-SM1-R	MSOP-8	Tape Reel

<p>U74LVC1G99G-S08-R</p> <p>(1) Packing Type</p> <p>(2) Package Type</p> <p>(3) Green Package</p>	<p>(1) R: Tape Reel, T: Tube</p> <p>(2) S08: SOP-8, SM1: MSOP-8</p> <p>(3) G: Halogen Free and Lead Free, L: Lead Free</p>
---	--

■ MARKING

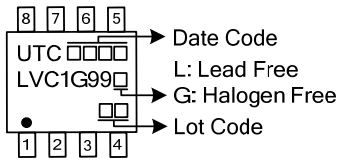

■ PIN CONFIGURATION

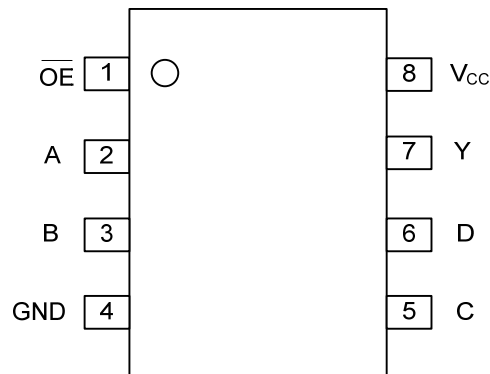

■ FUNCTION TABLE (EACH GATE)

INPUTS					OUTPUT
OE	D	C	B	A	Y
L	L	L	L	L	L
L	L	L	L	H	H
L	L	L	H	L	L
L	L	L	H	H	H
L	L	H	L	L	L
L	L	H	L	H	L
L	L	H	H	L	H
L	L	H	H	H	H
L	H	L	L	L	H
L	H	L	L	H	L
L	H	L	H	L	H
L	H	L	H	H	L
L	H	H	L	L	H
L	H	H	L	H	H
L	H	H	H	L	L
L	H	H	H	H	L
H	H or L	H or L	H or L	H or L	Z

Note: H: HIGH voltage level; L: LOW voltage level; Z: HIGH impedance state

■ LOGIC DIAGRAM (positive logic)

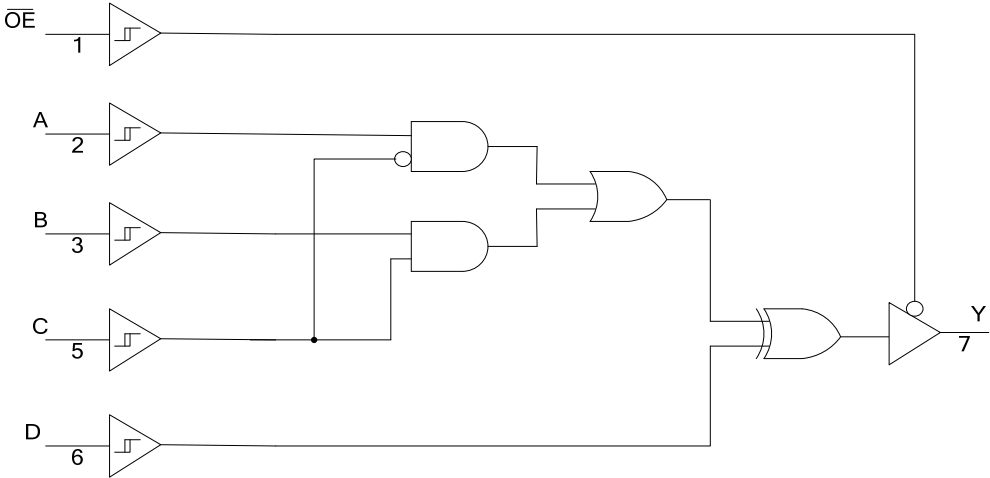

■ ABSOLUTE MAXIMUM RATING

PARAMETER		SYMBOL	RATINGS	UNIT
Supply Voltage		V_{CC}	-0.5 ~ +6.5	V
Input Voltage		V_{IN}	-0.5 ~ +6.5	V
Output Voltage	Output in the high or low state	V_{OUT}	-0.5 ~ $V_{CC}+0.5$	V
	Output in the high-impedance or power-off state		-0.5 ~ +6.5	V
V_{CC} or GND Current		I_{CC}	±100	mA
Continuous Output Current ($V_{OUT}=0$ to V_{CC})		I_{OUT}	±50	mA
Input Clamp Current ($V_{IN}<0$)		I_{IK}	-50	mA
Output Clamp Current ($V_{OUT}<0$)		I_{OK}	-50	mA
Storage Temperature Range		T_{STG}	-65 ~ +150	°C

Note: Absolute maximum ratings are those values beyond which the device could be permanently damaged. Absolute maximum ratings are stress ratings only and functional device operation is not implied.

■ RECOMMENDED OPERATING CONDITIONS

PARAMETER	SYMBOL	TEST CONDITIONS	MIN	TYP	MAX	UNIT
Supply Voltage	V_{CC}	Operating	1.65		5.5	V
		Data retention only	1.5			V
Input Voltage	V_{IN}		0		5.5	V
Output Voltage	V_{OUT}	High or low state	0		V_{CC}	V
High-level Output Current	I_{OH}	$V_{CC}=1.65V$			-4	mA
		$V_{CC}=2.3V$			-8	mA
		$V_{CC}=3V$			-16	mA
		$V_{CC}=3V$			-24	mA
		$V_{CC}=4.5V$			-32	mA
Low-level Output Current	I_{OL}	$V_{CC}=1.65V$			4	mA
		$V_{CC}=2.3V$			8	mA
		$V_{CC}=3V$			16	mA
		$V_{CC}=3V$			24	mA
		$V_{CC}=4.5V$			32	mA
Operating Temperature	T_A		-40		85	°C
Input Transition Rise or Fall Rate	$\Delta t/\Delta v$	$V_{CC}=1.8V\pm 0.15V, 2.5V\pm 0.2V$			20	ns/V
		$V_{CC}=3.3V\pm 0.3V$			10	ns/V
		$V_{CC}=5V\pm 0.5V$			5	ns/V

■ ELECTRICAL CHARACTERISTICS (T_A =25°C , unless otherwise specified)

PARAMETER	SYMBOL	TEST CONDITIONS	MIN	TYP	MAX	UNIT
Positive-Going Input Threshold Voltage	V _{T+}	V _{CC} =1.65V	0.79		1.26	V
		V _{CC} =2.3V	1.11		1.66	
		V _{CC} =3.0V	1.5		1.97	
		V _{CC} =4.5V	2.16		2.84	
		V _{CC} =5.5V	2.61		3.43	
Negative-Going Input Threshold Voltage	V _{T-}	V _{CC} =1.65V	0.39		0.72	V
		V _{CC} =2.3V	0.58		0.97	
		V _{CC} =3.0V	0.84		1.24	
		V _{CC} =4.5V	1.41		1.89	
		V _{CC} =5.5V	1.87		2.39	
Hysteresis Voltage (V _{T+} -V _{T-})	ΔV _T	V _{CC} =1.65V	0.37		0.72	V
		V _{CC} =2.3V	0.48		0.87	
		V _{CC} =3.0V	0.56		0.97	
		V _{CC} =4.5V	0.71		1.14	
		V _{CC} =5.5V	0.71		1.21	
High-Level Output Voltage	V _{OH}	V _{CC} =1.65V ~ 5.5V, I _{OH} =-100μA	V _{CC} -0.1			V
		V _{CC} =1.65V, I _{OH} =-4mA	1.2			
		V _{CC} =2.3V, I _{OH} =-8mA	1.9			
		V _{CC} =3.0V, I _{OH} =-16mA	2.4			
		V _{CC} =3.0V, I _{OH} =-24mA	2.3			
Low-Level Output Voltage	V _{OL}	V _{CC} =1.65V ~ 5.5V, I _{OL} =-100μA			0.1	V
		V _{CC} =1.65V, I _{OL} =4mA			0.45	
		V _{CC} =2.3V, I _{OL} =8mA			0.3	
		V _{CC} =3.0V, I _{OL} =16mA			0.4	
		V _{CC} =3.0V, I _{OL} =24mA			0.55	
Input Leakage Current	I _{I(LEAK)}	V _{CC} =0V ~ 5.5V, V _{IN} =V _{CC} or GND			±5	μA
Power OFF Leakage Current	I _{OFF}	V _{CC} =0V, V _{IN} or V _{OUT} =5.5V			±10	μA
High Impedance Output Leakage Current	I _{OZ}	V _{OUT} =V _{CC} or GND, V _{CC} =1.65V ~5.5V			±10	μA
Quiescent Supply Current	I _{CC}	V _{CC} =1.65V ~ 5.5V, V _{IN} =5.5V or GND I _{OUT} =0			±10	μA
Additional Quiescent Supply Current	ΔI _{CC}	V _{CC} =3V ~ 5.5V, One input at V _{CC} -0.6V, other inputs at V _{CC} or GND			500	μA
Input Capacitance	C _{IN}	V _{CC} =3.3V, V _{IN} =V _{CC} or GND		3.5		pF
Output Capacitance	C _{OUT}	V _{CC} =3.3V, V _{IN} =V _{CC} or GND		6		pF

■ SWITCHING CHARACTERISTICS (T_A =25°C , unless otherwise specified)

PARAMETER	SYMBOL	TEST CONDITIONS	MIN	TYP	MAX	UNIT
Propagation delay from input (A) to output(Y)	t _{PLH} /t _{PHL} (A to Y)	V _{CC} =1.8V±0.15V, C _L =15pF	4.5		30.1	ns
		V _{CC} =2.5V±0.2V, C _L =15pF	2.5		11.3	
		V _{CC} =3.3V±0.3V, C _L =15pF	1.8		7.5	
		V _{CC} =5V±0.5V, C _L =15pF	1.3		4.8	
Propagation delay from input (B) to output(Y)	t _{PLH} /t _{PHL} (B to Y)	V _{CC} =1.8V±0.15V, C _L =15pF	4.4		28.3	ns
		V _{CC} =2.5V±0.2V, C _L =15pF	2.4		10.8	
		V _{CC} =3.3V±0.3V, C _L =15pF	1.8		7.2	
		V _{CC} =5V±0.5V, C _L =15pF	1.3		4.7	
Propagation delay from input (C) to output(Y)	t _{PLH} /t _{PHL} (C to Y)	V _{CC} =1.8V±0.15V, C _L =15pF	4.4		29.1	ns
		V _{CC} =2.5V±0.2V, C _L =15pF	2.4		11.7	
		V _{CC} =3.3V±0.3V, C _L =15pF	1.9		7.6	
		V _{CC} =5V±0.5V, C _L =15pF	1.3		5.0	
Propagation delay from input (D) to output(Y)	t _{PLH} /t _{PHL} (D to Y)	V _{CC} =1.8V±0.15V, C _L =15pF	4.3		25.1	ns
		V _{CC} =2.5V±0.2V, C _L =15pF	2.4		10.2	
		V _{CC} =3.3V±0.3V, C _L =15pF	1.7		6.7	
		V _{CC} =5V±0.5V, C _L =15pF	1.3		4.5	
Propagation delay from Output-enable(OE) to output(Y)	t _{PZL} /t _{PZH}	V _{CC} =1.8V±0.15V, C _L =15pF	3.4		24.7	ns
		V _{CC} =2.5V±0.2V, C _L =15pF	2.1		10.0	
		V _{CC} =3.3V±0.3V, C _L =15pF	1.3		5.8	
		V _{CC} =5V±0.5V, C _L =15pF	1.0		3.8	
Propagation delay from Output-enable(OE) to output(Y)	t _{PZL} /t _{PZH}	V _{CC} =1.8V±0.15V, C _L =15pF	4.0		15.5	ns
		V _{CC} =2.5V±0.2V, C _L =15pF	2.7		7.5	
		V _{CC} =3.3V±0.3V, C _L =15pF	3.5		7.0	
		V _{CC} =5V±0.5V, C _L =15pF	2		5.5	

■ SWITCHING CHARACTERISTICS

PARAMETER	SYMBOL	TEST CONDITIONS	MIN	TYP	MAX	UNIT
Propagation delay from input (A) to output(Y)	t _{PLH} /t _{PHL} (A to Y)	V _{CC} =1.8V±0.15V, C _L =50pF	4.6		30.8	ns
		V _{CC} =2.5V±0.2V, C _L =50pF	2.6		11.7	
		V _{CC} =3.3V±0.3V, C _L =50pF	2.4		8.4	
		V _{CC} =5V±0.5V, C _L =50pF	1.8		5.5	
Propagation delay from input (B) to output(Y)	t _{PLH} /t _{PHL} (B to Y)	V _{CC} =1.8V±0.15V, C _L =50pF	4.6		28.9	ns
		V _{CC} =2.5V±0.2V, C _L =50pF	2.6		11.3	
		V _{CC} =3.3V±0.3V, C _L =50pF	2.3		8.2	
		V _{CC} =5V±0.5V, C _L =50pF	1.8		5.4	
Propagation delay from input (C) to output(Y)	t _{PLH} /t _{PHL} (C to Y)	V _{CC} =1.8V±0.15V, C _L =50pF	4.4		29.8	ns
		V _{CC} =2.5V±0.2V, C _L =50pF	2.5		12.3	
		V _{CC} =3.3V±0.3V, C _L =50pF	2.5		8.6	
		V _{CC} =5V±0.5V, C _L =50pF	1.8		5.7	
Propagation delay from input (D) to output(Y)	t _{PLH} /t _{PHL} (D to Y)	V _{CC} =1.8V±0.15V, C _L =50pF	4.3		25.7	ns
		V _{CC} =2.5V±0.2V, C _L =50pF	2.5		10.7	
		V _{CC} =3.3V±0.3V, C _L =50pF	2.4		7.6	
		V _{CC} =5V±0.5V, C _L =50pF	1.6		5.2	
Propagation delay from Output-enable(OE) to output(Y)	t _{PZL} /t _{PZH}	V _{CC} =1.8V±0.15V, C _L =50pF	4.2		25.2	ns
		V _{CC} =2.5V±0.2V, C _L =50pF	2.4		11.3	
		V _{CC} =3.3V±0.3V, C _L =50pF	2.0		7.0	
		V _{CC} =5V±0.5V, C _L =50pF	1.7		4.7	
Propagation delay from Output-enable(OE) to output(Y)	t _{PZL} /t _{PZH}	V _{CC} =1.8V±0.15V, C _L =50pF	3.7		15	ns
		V _{CC} =2.5V±0.2V, C _L =50pF	2		5.8	
		V _{CC} =3.3V±0.3V, C _L =50pF	2.1		5.6	
		V _{CC} =5V±0.5V, C _L =50pF	1.0		4.5	

■ OPERATING CHARACTERISTICS (T_A=25°C , unless otherwise specified)

PARAMETER	SYMBOL	TEST CONDITIONS	MIN	TYP	MAX	UNIT
Power Dissipation Capacitance	C _{PD}	V _{CC} =3.3V, f=10MHz		22		pF

TEST CIRCUIT AND WAVEFORMS

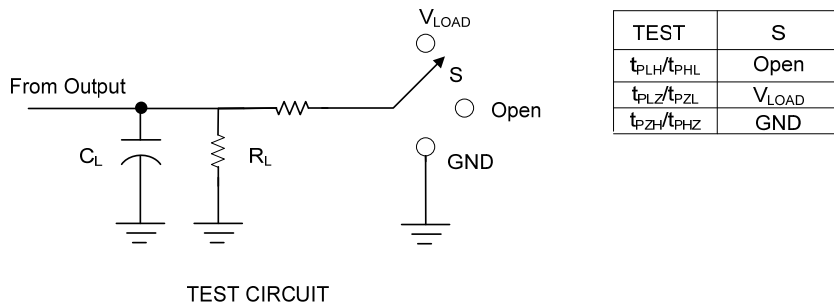

V_{CC}	Inputs		V_M	V_{LOAD}	C_L	R_L	V_{Δ}
	V_{IN}	t_R, t_F					
$1.8V \pm 0.15V$	V_{CC}	$\leq 2ns$	$V_{CC}/2$	$2 \times V_{CC}$	15pF	1M Ω	0.15V
$2.5V \pm 0.2V$	V_{CC}	$\leq 2ns$	$V_{CC}/2$	$2 \times V_{CC}$	15pF	1M Ω	0.15V
$3.3V \pm 0.3V$	3V	$\leq 2.5ns$	1.5V	6V	15pF	1M Ω	0.3V
$5V \pm 0.5V$	V_{CC}	$\leq 2.5ns$	$V_{CC}/2$	$2 \times V_{CC}$	15pF	1M Ω	0.3V
$1.8V \pm 0.15V$	V_{CC}	$\leq 2ns$	$V_{CC}/2$	$2 \times V_{CC}$	30pF	1K Ω	0.15V
$2.5V \pm 0.2V$	V_{CC}	$\leq 2ns$	$V_{CC}/2$	$2 \times V_{CC}$	30pF	500 Ω	0.15V
$3.3V \pm 0.3V$	3V	$\leq 2.5ns$	1.5V	6V	50pF	500 Ω	0.3V
$5V \pm 0.5V$	V_{CC}	$\leq 2.5ns$	$V_{CC}/2$	$2 \times V_{CC}$	50pF	500 Ω	0.3V

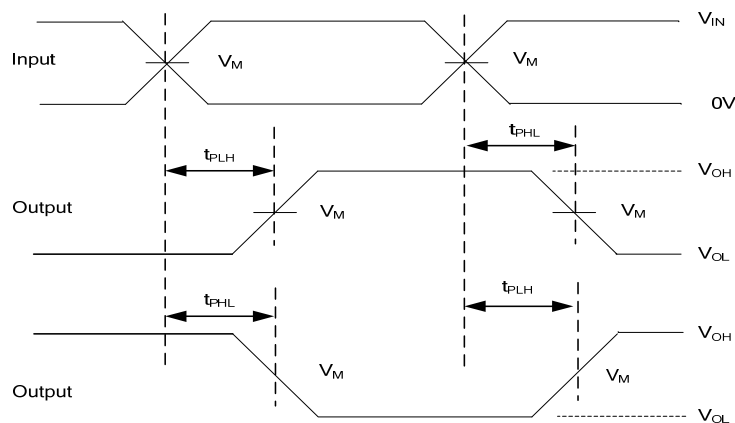

■ TEST CIRCUIT AND WAVEFORMS (Cont.)

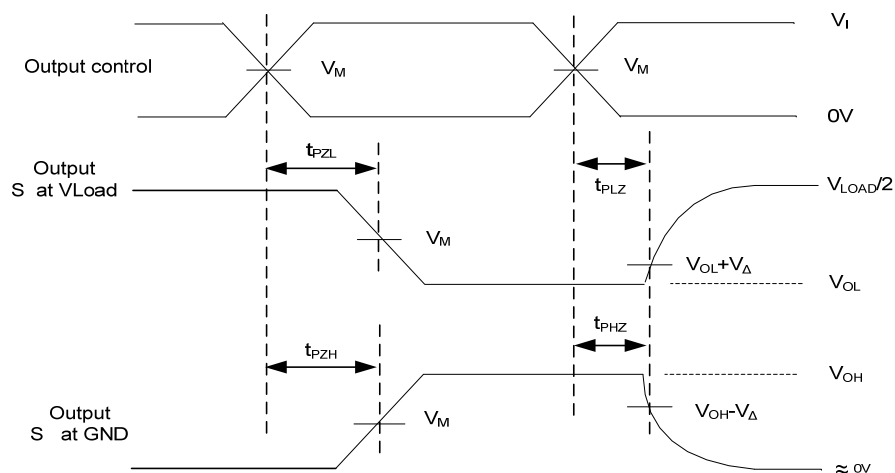

ENABLE AND DISABLE TIMES

Note: 1. C_L includes probe and jig capacitance.

2. All input pulses are supplied by generators having the following characteristics: PRR ≤ 10 MHz, $Z_o = 50\Omega$.

UTC assumes no responsibility for equipment failures that result from using products at values that exceed, even momentarily, rated values (such as maximum ratings, operating condition ranges, or other parameters) listed in products specifications of any and all UTC products described or contained herein. UTC products are not designed for use in life support appliances, devices or systems where malfunction of these products can be reasonably expected to result in personal injury. Reproduction in whole or in part is prohibited without the prior written consent of the copyright owner. UTC reserves the right to make changes to information published in this document, including without limitation specifications and product descriptions, at any time and without notice. This document supersedes and replaces all information supplied prior to the publication hereof.