



U74LVC2G08

CMOS IC

DUAL 2-INPUT AND GATE

DESCRIPTION

The **U74LVC2G08** is a dual 2-input AND gate which performs the function $Y=A*B$ or $Y=\overline{A+B}$. It is designed for 1.65V to 5.5V operation.

FEATURES

- * Wide Supply Voltage Range from 1.65V to 5.5V
- * Max t_{PD} of 4.7 ns at 3.3V
- * Up to 5V Inputs Accept Voltages
- * Low Power Consumption, $I_{CC} = 10 \mu A$ (Max.)
- * ± 24 mA Output Driver at 3V
- * Direct Interface with TTL Levels

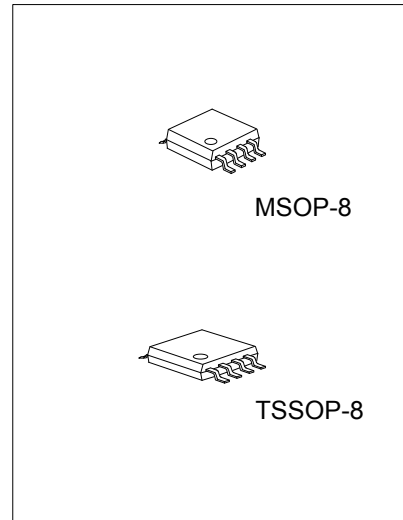

ORDERING INFORMATION

Ordering Number		Package	Packing
Lead Free	Halogen Free		
U74LVC2G08L-SM1-R	U74LVC2G08G-SM1-R	MSOP-8	Tape Reel
U74LVC2G08L-P08-R	U74LVC2G08G-P08-R	TSSOP-8	Tape Reel

<p>U74LVC2G08G-SM1-R</p> <p>(1) Packing Type (2) Package Type (3) Green Package</p>	<p>(1) R: Tape Reel (2) SM1: MSOP-8, P08: TSSOP-8 (3) G: Halogen Free and Lead Free, L: Lead Free</p>
---	---

MARKING

MSOP-8	TSSOP-8
<p>8 7 6 5 → Date Code UTC □ □ □ □ 308 □ → L: Lead Free □ □ → G: Halogen Free ● □ □ □ → Lot Code 1 2 3 4</p>	<p>8 → Date Code 1 UTC □ □ □ □ 2 308 □ → L: Lead Free 3 □ □ → G: Halogen Free 4 □ □ □ → Lot Code</p>

■ PIN CONFIGURATION

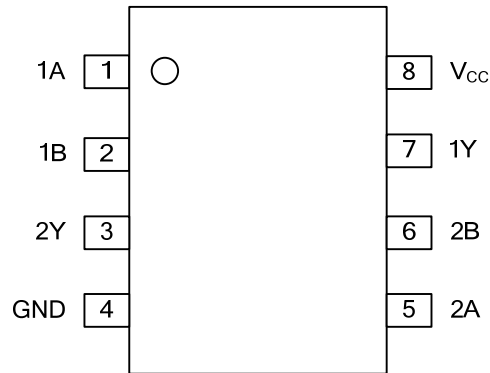

■ FUNCTION TABLE (Each Gate)

INPUTS		OUTPUT
A	B	Y
L	L	L
L	H	L
H	L	L
H	H	H

■ LOGIC DIAGRAM (Positive Logic)

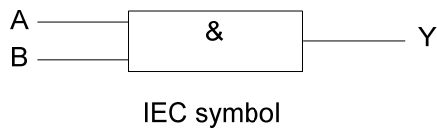
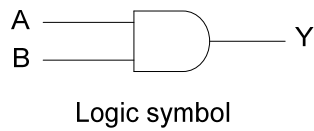

■ ABSOLUTE MAXIMUM RATING (Note)

PARAMETER	SYMBOL	RATINGS	UNIT
Supply Voltage	V_{CC}	-0.5~6.5	V
Input Voltage	V_{IN}	-0.5~6.5	V
Output Voltage (Active Mode)	V_{OUT}	-0.5~ $V_{CC}+0.5$	V
Output Voltage (Power-Down Mode)	V_{OUT}	-0.5~+6.5	V
Input Clamp Current	I_{IK}	-50	mA
Output Clamp Current	I_{OK}	±50	mA
Output Current	I_{OUT}	±50	mA
V_{CC} or GND Current	I_{CC}	±100	mA
Power Dissipation	P_{TOT}	300	mW
Storage Temperature	T_{STG}	-65 ~ +150	°C

Notes: 1. Absolute maximum ratings are those values beyond which the device could be permanently damaged. Absolute maximum ratings are stress ratings only and functional device operation is not implied.
 2. The input and output voltage ratings may be exceeded if the input and output current ratings are observed.

■ RECOMMENDED OPERATING CONDITIONS

PARAMETER	SYMBOL	CONDITIONS	MIN	TYP	MAX	UNIT
Supply Voltage	V_{CC}	Operating	1.65		5.5	V
Input Voltage	V_{IN}		0		5.5	V
Output Voltage	V_{OUT}	Active Mode	0		V_{CC}	V
		Power-Down Mode; $V_{CC} = 0V$;	0		5.5	
Input Transition Rise or Fall Rate	t_R / t_F	$V_{CC}=1.65V$ to $2.7V$			20	ns/V
		$V_{CC}=2.7V$ to $5.5V$			10	
Operating Temperature	T_{OPR}		-40		125	°C

■ ELECTRICAL CHARACTERISTICS ($T_A=25^\circ C$, unless otherwise specified)

PARAMETER	SYMBOL	TEST CONDITIONS	MIN	TYP	MAX	UNIT	
High-Level Input Voltage	V_{IH}	$V_{CC}=1.65V\sim 1.95V$	$0.65 \times V_{CC}$			V	
		$V_{CC}=2.3V\sim 2.7V$	1.7				
		$V_{CC}=2.7V\sim 3.6V$	2.0				
		$V_{CC}=4.5V\sim 5.5V$	$0.7 \times V_{CC}$				
Low-Level Input Voltage	V_{IL}	$V_{CC}=1.65V\sim 1.95V$			$0.35 \times V_{CC}$	V	
		$V_{CC}=2.3V\sim 2.7V$			0.7		
		$V_{CC}=2.7V\sim 3.6V$			0.8		
		$V_{CC}=4.5V\sim 5.5V$			$0.3 \times V_{CC}$		
High-Level Output Voltage	V_{OH}	$V_{CC}=1.65V\sim 5.5V$	$I_{OH}=-100\mu A$	$V_{CC}-0.1$		V	
		$V_{CC}=1.65V$	$I_{OH}=-4mA$	1.2	1.53		
		$V_{CC}=2.3V$	$I_{OH}=-8mA$	1.9	2.13		
		$V_{CC}=2.7V$	$I_{OH}=-12mA$	2.2	2.50		
		$V_{CC}=4.5V$	$I_{OH}=-32mA$	3.8	4.10		
Low-Level Output Voltage	V_{OL}	$V_{CC}=1.65V\sim 5.5V$	$I_{OL}=100\mu A$		0.1	V	
		$V_{CC}=1.65V$	$I_{OL}=4mA$		0.08		0.45
		$V_{CC}=2.3V$	$I_{OL}=8mA$		0.14		0.3
		$V_{CC}=2.7V$	$I_{OL}=12mA$		0.19		0.4
		$V_{CC}=3.0V$	$I_{OL}=24mA$		0.37		0.55
		$V_{CC}=4.5V$	$I_{OL}=32mA$		0.43		0.55
Input Leakage Current	$I_{I(LEAK)}$	$V_{IN}=5.5V$ or GND, $V_{CC}=5.5V$		±0.1	±5	μA	
OFF-state Current	I_{OFF}	V_{IN} or $V_O = 5.5V$, $V_{CC}=0V$		±0.1	±10	μA	
Quiescent Supply Current	I_Q	$V_{IN}=V_{CC}$ or GND, $I_{OUT}=0$, $V_{CC}=5.5V$		0.1	10	μA	
Additional quiescent Supply Current	ΔI_Q	One input at $V_{CC}-0.6V$; other inputs at V_{CC} or GND; $V_{CC}=2.3V\sim 5.5V$		5	500	μA	
Input Capacitance	C_{IN}			2.5		pF	

■ SWITCHING CHARACTERISTICS (T_A=25°C, unless otherwise specified)

PARAMETER	SYMBOL	TEST CONDITIONS	MIN	TYP	MAX	UNIT	
Propagation delay from input (A or B) to output (Y)	t _{PLH} / t _{PHL}	V _{CC} =1.8V±0.15V, R _L =1KΩ	C _L =30pF	1.0	3.2	9.0	ns
		V _{CC} =2.5V±0.2V, R _L =500Ω		0.5	2.2	5.1	
		V _{CC} =2.7V, R _L =500Ω	C _L =50pF	1.0	2.5	5.3	
		V _{CC} =3.3V±0.3V, R _L =500Ω		0.5	2.1	4.7	
		V _{CC} =5.0V±0.5V, R _L =500Ω		0.5	1.7	3.8	

■ OPERATING CHARACTERISTICS (T_A=25°C, unless otherwise specified)

PARAMETER	SYMBOL	TEST CONDITIONS	MIN	TYP	MAX	UNIT
Power Dissipation Capacitance	C _{PD}	V _{CC} = 3.3V		14.4		pF

Notes: 1. C_{PD} is used to determine the dynamic power dissipation (P_D in μW).

$$P_D = C_{PD} \times V_{CC}^2 \times f_i \times N + \sum (C_L \times V_{CC}^2 \times f_o), \text{ where:}$$

f_i = input frequency in MHz;

f_o = output frequency in MHz;

C_L = output load capacitance in pF;

V_{CC} = supply voltage in Volts;

N = total load switching outputs;

$\sum (C_L \times V_{CC}^2 \times f_o)$ = sum of outputs.

2. The condition is V_I = GND to V_{CC}.

■ TEST CIRCUIT AND WAVEFORMS

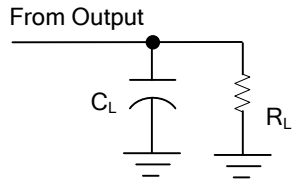

TEST CIRCUIT

V _{CC}	INPUTS		V _M	C _L	R _L
	V _{IN}	t _R , t _F			
1.65 V to 1.95 V	V _{CC}	≤2ns	V _{CC} /2	30pF	1KΩ
2.3 V to 2.7 V	V _{CC}	≤2ns	V _{CC} /2	30pF	500Ω
2.7 V	2.7V	≤2.5ns	1.5V	50pF	500Ω
3.0 V to 3.6 V	2.7V	≤2.5ns	1.5V	50pF	500Ω
4.5 V to 5.5 V	V _{CC}	≤2.5ns	V _{CC} /2	50pF	500Ω

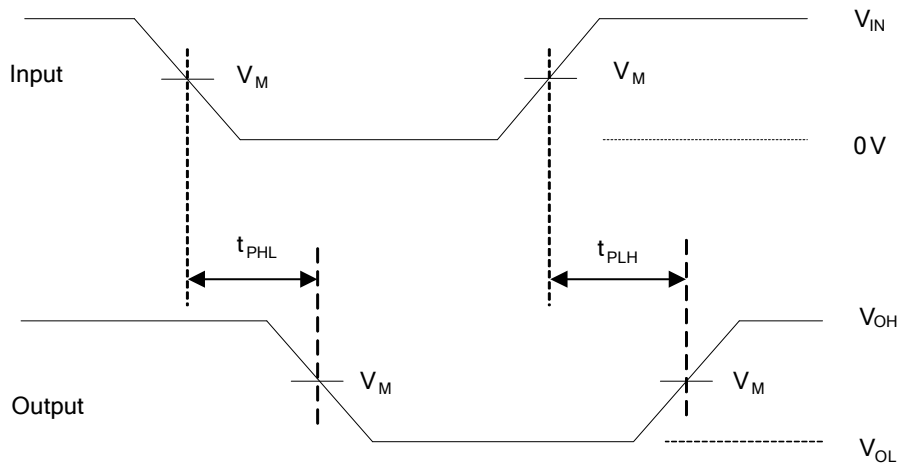

Notes: 1. C_L includes probe and jig capacitance.

2. All input pulses are supplied by generators having the following characteristics: P_{RR} ≤ 1 MHz, Z_O = 50 Ω, t_R ≤ 3 ns, t_F ≤ 3 ns.

UTC assumes no responsibility for equipment failures that result from using products at values that exceed, even momentarily, rated values (such as maximum ratings, operating condition ranges, or other parameters) listed in products specifications of any and all UTC products described or contained herein. UTC products are not designed for use in life support appliances, devices or systems where malfunction of these products can be reasonably expected to result in personal injury. Reproduction in whole or in part is prohibited without the prior written consent of the copyright owner. UTC reserves the right to make changes to information published in this document, including without limitation specifications and product descriptions, at any time and without notice. This document supersedes and replaces all information supplied prior to the publication hereof.