



## U74LVC2G125

CMOS IC

### DUAL BUS BUFFER GATE WITH 3-STATE OUTPUTS

#### DESCRIPTION

The **U74LVC2G125** consists of two bus buffers with 3-state output controlled by enable input ( $\overline{nOE}$ ), when  $\overline{nOE}$  is high, the output is disable.

Inputs can be driven from either 3.3V or 5V devices, so the device can be used in a mix 3.3V/5V system.

This device is full specified for partial power-down protective circuit, preventing the backflow current through the device when it is powered down.

#### FEATURES

- \* Operation Voltage Range: 1.65~5.5V
- \* Low Power Dissipation
- \* Input Accept Voltage to 5.5V

#### ORDERING INFORMATION

Ordering Number		Package	Packing
Lead Free	Halogen Free		
U74LVC2G125L-SM1-R	U74LVC2G125G-SM1-R	MSOP-8	Tape Reel
U74LVC2G125L-P08-R	U74LVC2G125G-P08-R	TSSOP-8	Tape Reel

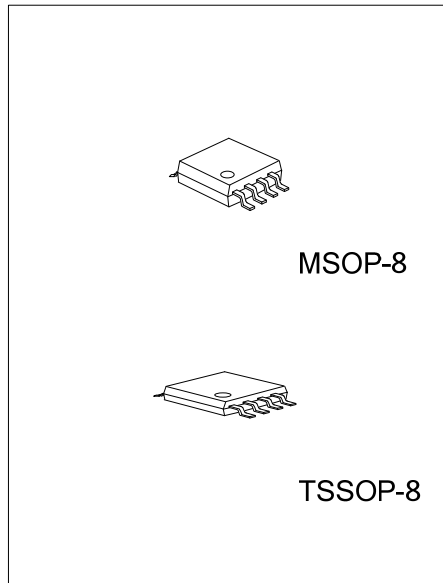

<p>U74LVC2G125G-SM1-R</p> <p>(1) Packing Type (2) Package Type (3) Green Package</p>	<p>(1) R: Tape Reel (2) SM1: MSOP-8, P08: TSSOP-8 (3) G: Halogen Free and Lead Free, L: Lead Free</p>
--	---

#### MARKING

MSOP-8	TSSOP-8
<p>8 7 6 5 → Date Code UTC □ □ □ □ 3125 □ → L: Lead Free □ → G: Halogen Free □ → Lot Code 1 2 3 4</p>	<p>8 → Date Code UTC □ □ □ □ 3125 □ → L: Lead Free □ → G: Halogen Free □ → Lot Code 1 2 3 4</p>

■ PIN CONFIGURATION

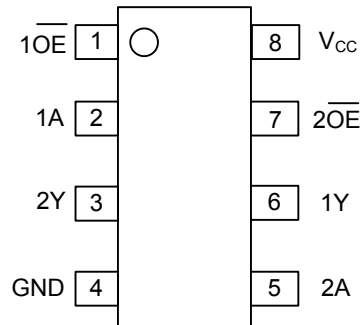

■ FUNCTION TABLE (each gate)

INPUT		OUTPUT
$\overline{nOE}$	A	Y
L	L	L
L	H	H
H	X	Z

■ LOGIC DIAGRAM (positive logic)

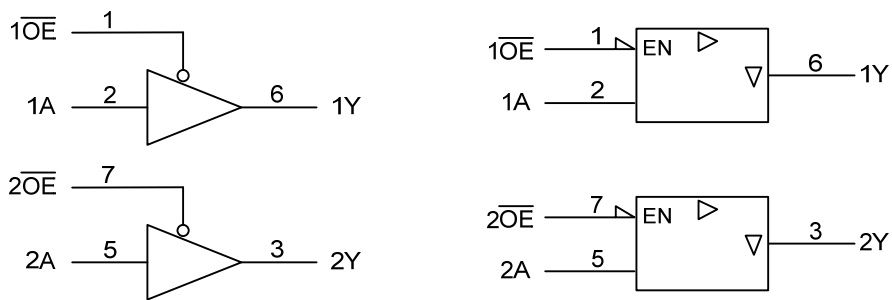

### ■ ABSOLUTE MAXIMUM RATING (unless otherwise specified)(Note 1)

PARAMETER		SYMBOL	RATINGS	UNIT
Supply Voltage		$V_{CC}$	-0.5~6.5	V
Input Voltage		$V_{IN}$	-0.5~6.5	V
Output Voltage	Enable mode	$V_{OUT}$	-0.5~ $V_{CC}+0.5$	V
	Disable mode	$V_{OUT}$	-0.5~6.5	V
	Power-down mode	$V_{OUT}$	-0.5~6.5	V
Input Clamp Current ( $V_{IN}<0$ )		$I_{IK}$	-50	mA
Output Clamp Current ( $V_{OUT}<0$ )		$I_{OK}$	-50	mA
Output Current		$I_{OUT}$	$\pm 50$	mA
$V_{CC}$ or GND Current		$I_{CC}$	$\pm 100$	mA
Power Dissipation		$P_D$	500	mW
Storage Temperature		$T_{STG}$	-65 ~ +150	$^{\circ}C$

Note 1. The input and output voltage ratings may be exceeded if the input and output current ratings are observed.

2. Absolute maximum ratings are those values beyond which the device could be permanently damaged.

Absolute maximum ratings are stress ratings only and functional device operation is not implied.

### ■ RECOMMENDED OPERATING CONDITIONS

PARAMETER	SYMBOL	TEST CONDITIONS	MIN	TYP	MAX	UNIT
Supply Voltage	$V_{CC}$	Operating	1.65		5.5	V
Input Voltage	$V_{IN}$		0		5.5	V
Output Voltage	$V_{OUT}$	$V_{CC}=1.65V\sim 5.5V$ ; Enable mode	0		$V_{CC}$	V
		$V_{CC}=1.65V\sim 5.5V$ ; Disable mode	0		5.5	V
		$V_{CC}=0V$ ; Power-down mode	0		5.5	V
Input Transition Rise or Fall Rate	$t_R, t_F$	$V_{CC}=1.65\sim 2.7V$	0		20	ns/V
		$V_{CC}=2.7\sim 5.5V$	0		10	ns/V
Operating Temperature	$T_A$		-40		85	$^{\circ}C$

### ■ STATIC CHARACTERISTICS ( $T_A=25^{\circ}C$ )

PARAMETER	SYMBOL	TEST CONDITIONS	MIN	TYP	MAX	UNIT
High-Level Input Voltage	$V_{IH}$	$V_{CC} = 1.65V \sim 1.95V$	$0.65 \times V_{CC}$			V
		$V_{CC} = 2.3V \sim 2.7V$	1.7			V
		$V_{CC} = 2.7V \sim 3.6V$	2			V
		$V_{CC} = 4.5V \sim 5.5V$	$0.7 \times V_{CC}$			V
Low-Level Input Voltage	$V_{IL}$	$V_{CC} = 1.65V \sim 1.95V$			$0.35 \times V_{CC}$	V
		$V_{CC} = 2.3V \sim 2.7V$			0.7	V
		$V_{CC} = 2.7V \sim 3.6V$			0.8	V
		$V_{CC} = 4.5V \sim 5.5V$			$0.3 \times V_{CC}$	V
High-Level Output Voltage	$V_{OH}$	$V_{CC} = 1.65V \sim 5.5V, I_{OH}=-100\mu A$	$V_{CC}-0.1$			V
		$V_{CC} = 1.65V, I_{OH}=-4mA$	1.2			V
		$V_{CC} = 2.3V, I_{OH}=-8mA$	1.9			V
		$V_{CC} = 2.7V, I_{OH}=-12mA$	2.2			V
		$V_{CC} = 3V, I_{OH}=-24mA$	2.3			V
		$V_{CC} = 4.5V, I_{OH}=-32mA$	3.8			V
Low-Level Output Voltage	$V_{OL}$	$V_{CC} = 1.65V \sim 5.5V, I_{OL}=100\mu A$			0.1	V
		$V_{CC} = 1.65V, I_{OL}=4mA$			0.45	V
		$V_{CC} = 2.3V, I_{OL}=8mA$			0.3	V
		$V_{CC} = 2.7V, I_{OL}=12mA$			0.4	V
		$V_{CC} = 3V, I_{OL}=24mA$			0.55	V
		$V_{CC} = 4.5V, I_{OL}=32mA$			0.55	V

## ■ STATIC CHARACTERISTICS (Cont.)

PARAMETER	SYMBOL	TEST CONDITIONS	MIN	TYP	MAX	UNIT
Input Leakage Current	$I_{I(LEAK)}$	$V_{CC} = 5.5V, V_{IN} = 5.5V$ or GND		±0.1	±5	μA
Output OFF-State Current	$I_{OZ}$	$V_{CC} = 3.6V, V_{OUT} = V_{CC}$ or GND		±0.1	±10	μA
Power OFF Leakage Current	$I_{OFF(LEAK)}$	$V_{CC} = 0V, V_{IN}$ or $V_{OUT} = 5.5V$		±0.1	±10	μA
Quiescent Supply Current	$I_Q$	$V_{CC} = 5.5V, V_{IN} = V_{CC}$ or GND, $I_{OUT} = 0$		0.1	10	μA
Additional Quiescent Supply Current	$\Delta I_Q$	$V_{CC} = 2.3V \sim 5.5V$ , One input at $V_{CC} - 0.6V$ , other inputs at $V_{CC}$ or GND		5	500	μA
Input Capacitance	$C_{IN}$	$V_{IN} = V_{CC}$ or GND		2		pF

## ■ DYNAMIC CHARACTERISTICS ( $T_A = 25^\circ C$ )

PARAMETER	SYMBOL	TEST CONDITIONS	MIN	TYP	MAX	UNIT
Propagation Delay From Input (A) to Output(Y)	$t_{PLH}/t_{PHL}$	$V_{CC} = 1.8V \pm 0.15$	1	3.7	9.1	ns
		$V_{CC} = 2.5V \pm 0.2$	0.5	2.5	4.8	
		$V_{CC} = 2.7V$	1	2.7	4.8	
		$V_{CC} = 3.3V \pm 0.3$	0.5	2.3	4.3	
		$V_{CC} = 5V \pm 0.5$	0.5	1.9	3.7	
Propagation Delay From Input ( $\overline{nOE}$ ) to Output(Y)	$t_{PZL}/t_{PZH}$	$V_{CC} = 1.8V \pm 0.15$	1.5	4.3	9.9	ns
		$V_{CC} = 2.5V \pm 0.2$	1	2.8	5.6	
		$V_{CC} = 2.7V$	1.5	3.3	5.7	
		$V_{CC} = 3.3V \pm 0.3$	0.5	2.4	4.7	
		$V_{CC} = 5V \pm 0.5$	0.5	2	3.8	
Propagation Delay From Input ( $\overline{nOE}$ ) to Output(Y)	$t_{PLZ}/t_{PHZ}$	$V_{CC} = 1.8V \pm 0.15$	1	3.5	11.6	ns
		$V_{CC} = 2.5V \pm 0.2$	0.5	1.8	5.8	
		$V_{CC} = 2.7V$	1	2.7	4.8	
		$V_{CC} = 3.3V \pm 0.3$	1	2.7	4.6	
		$V_{CC} = 5V \pm 0.5$	0.5	1.8	3.4	

## ■ OPERATING CHARACTERISTICS

PARAMETER	SYMBOL	TEST CONDITIONS	MIN	TYP	MAX	UNIT
Power Dissipation Capacitance	Cpd	Output Enable, f=10MHz		18		pF
		Output Disable, f=10MHz		5		

## TEST CIRCUIT AND WAVEFORMS

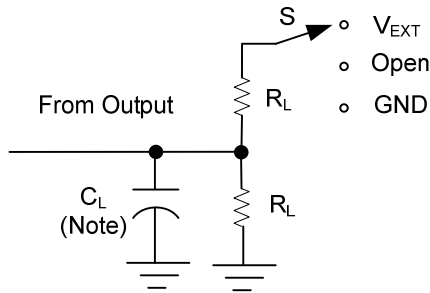

TEST	S
$t_{PLH}/t_{PHL}$	Open
$t_{PHZ}/t_{PZH}$	GND
$t_{PLZ}/t_{PZL}$	$V_{EXT}$

Note:  $C_L$  includes probe and jig capacitance.

$V_{CC}$	$V_{IN}$	$t_r, t_f$	$V_M$	$V_{EXT}$	$C_L$	$R_L$	$V_{\Delta}$
$1.8V \pm 0.15V$	$V_{CC}$	$\leq 2ns$	$V_{CC}/2$	$2 \times V_{CC}$	30pF	1K $\Omega$	0.15V
$2.5V \pm 0.2V$	$V_{CC}$	$\leq 2ns$	$V_{CC}/2$	$2 \times V_{CC}$	30pF	500 $\Omega$	0.15V
2.7V	2.7V	$\leq 2.5ns$	1.5V	6V	50pF	500 $\Omega$	0.3V
$3.3V \pm 0.3V$	2.7V	$\leq 2.5ns$	1.5V	6V	50pF	500 $\Omega$	0.3V
$5V \pm 0.5V$	$V_{CC}$	$\leq 2.5ns$	$V_{CC}/2$	$2 \times V_{CC}$	50pF	500 $\Omega$	0.3V

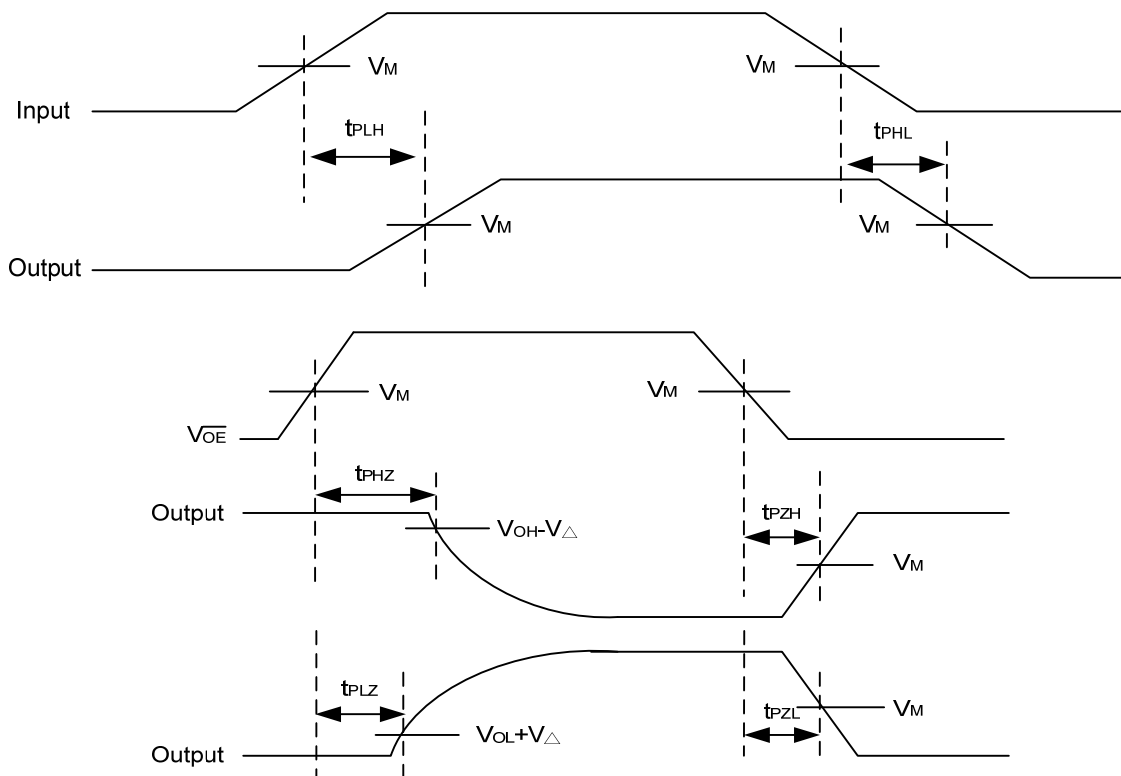

UTC assumes no responsibility for equipment failures that result from using products at values that exceed, even momentarily, rated values (such as maximum ratings, operating condition ranges, or other parameters) listed in products specifications of any and all UTC products described or contained herein. UTC products are not designed for use in life support appliances, devices or systems where malfunction of these products can be reasonably expected to result in personal injury. Reproduction in whole or in part is prohibited without the prior written consent of the copyright owner. UTC reserves the right to make changes to information published in this document, including without limitation specifications and product descriptions, at any time and without notice. This document supersedes and replaces all information supplied prior to the publication hereof.