

μA107 • μA207 • μA307

GENERAL-PURPOSE OPERATIONAL AMPLIFIERS

FAIRCHILD LINEAR INTEGRATED CIRCUITS

GENERAL DESCRIPTION – The μA107 General Purpose Operational Amplifier series is constructed using the Fairchild Planar* epitaxial process. Advanced processing techniques have reduced the 107 input current an order of magnitude below industry standards such as the μA709 while still replacing, pin-for-pin, μA709, μA101, μA101A, and μA741. The μA107, μA207, and μA307 offer better accuracy, internal compensation, and lower noise for high impedance circuit applications while providing features similar to the μA101A. The low input currents allow the device to be used in slow-charge applications such as long period integrators, slow ramps, and sample-and-hold circuits. The μA207 is identical to the μA107 except that the μA207 performance is guaranteed from -25°C to $+85^{\circ}\text{C}$ while the μA107 performance is guaranteed over a -55°C to $+125^{\circ}\text{C}$ temperature range. The μA307 is available in both TO-99 and 8-pin mini DIP packages and is guaranteed over a 0°C to $+70^{\circ}\text{C}$ temperature range.

- LOW OFFSET VOLTAGE
- LOW INPUT CURRENT
- LOW OFFSET CURRENT
- GUARANTEED DRIFT CHARACTERISTICS
- GUARANTEED OFFSETS OVER COMMON MODE RANGE

EQUIVALENT CIRCUIT

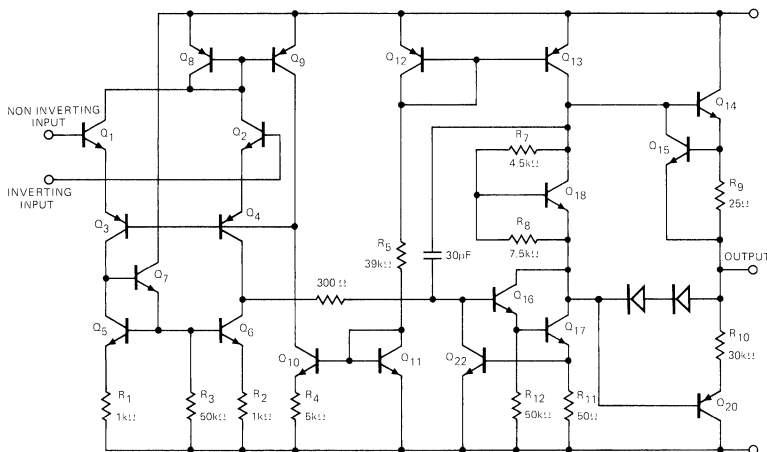

Pin connections shown are for metal can.

CONNECTION DIAGRAMS 8-PIN METAL CAN

(TOP VIEW)
PACKAGE OUTLINE 5S
PACKAGE CODE H

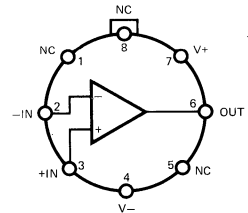

Note: Pin 4 connected to case.

ORDER INFORMATION

TYPE	PART NO.
μA107	μA107HM
μA207	μA207HM
μA307	μA307HC

8-PIN MINI DIP

(TOP VIEW)
PACKAGE OUTLINE 9T
PACKAGE CODE T

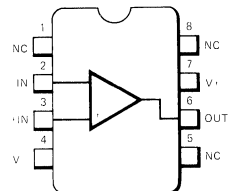

ORDER INFORMATION

TYPE	PART NO.
μA307	μA307TC

Dual In-line Package
and Flatpak Available
By Special Request

*Planar is patented Fairchild process.

FAIRCHILD • μ A107 • μ A207 • μ A307

μ A307

ELECTRICAL CHARACTERISTICS: $\pm 5.0 \text{ V} \leq V_S \leq \pm 15 \text{ V}$, $T_A = 25^\circ\text{C}$ unless otherwise specified.

CHARACTERISTICS	CONDITIONS	MIN	TYP	MAX	UNITS
Input Offset Voltage	$R_S \leq 50 \text{ k}\Omega$		2.0	7.5	mV
Input Offset Current			3.0	50	nA
Input Bias Current			70	250	nA
Input Resistance		0.5	2.0		$\text{M}\Omega$
Supply Current	$V_S = \pm 15 \text{ V}$		1.8	3.0	mA
Large Signal Voltage Gain	$V_S = \pm 15 \text{ V}$ $V_{OUT} = \pm 10 \text{ V}$, $R_L \geq 2 \text{ k}\Omega$	25	160		V/mV
The following specifications apply for $0^\circ\text{C} \leq T_A \leq 70^\circ\text{C}$					
Input Offset Voltage	$R_S \leq 50 \text{ k}\Omega$			10	mV
Average Temperature Coefficient of Input Offset Voltage			6.0	30	$\mu\text{V}/^\circ\text{C}$
Input Offset Current				70	nA
Average Temperature Coefficient of Input Offset Current	$25^\circ\text{C} \leq T_A \leq 70^\circ\text{C}$ $0^\circ\text{C} \leq T_A \leq 25^\circ\text{C}$		0.01 0.02	0.3 0.6	$\text{nA}/^\circ\text{C}$ $\text{nA}/^\circ\text{C}$
Input Bias Current				300	nA
Large Signal Voltage Gain	$V_S = \pm 15 \text{ V}$, $V_{OUT} = \pm 10 \text{ V}$ $R_L \geq 2 \text{ k}\Omega$	15			V/mV
Output Voltage Swing	$V_S = \pm 15 \text{ V}$	$R_L = 10 \text{ k}\Omega$	± 12	± 14	V
		$R_L = 2 \text{ k}\Omega$	± 10	± 13	V
Input Voltage Range	$V_S = \pm 15 \text{ V}$	± 12			V
Common Mode Rejection Ratio	$R_S \leq 50 \text{ k}\Omega$	70	90		dB
Supply Voltage Rejection Ratio	$R_S \leq 50 \text{ k}\Omega$	70	96		dB

GUARANTEED PERFORMANCE CURVES FOR μ A107 AND μ A207

INPUT VOLTAGE RANGE AS A FUNCTION OF SUPPLY VOLTAGE

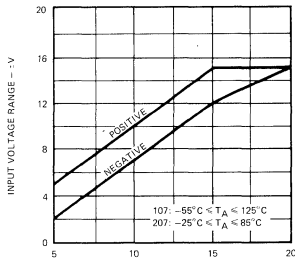

SUPPLY VOLTAGE - +V

OUTPUT SWING AS A FUNCTION OF SUPPLY VOLTAGE

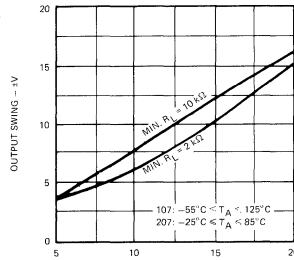

SUPPLY VOLTAGE - +V

VOLTAGE GAIN AS A FUNCTION OF SUPPLY VOLTAGE

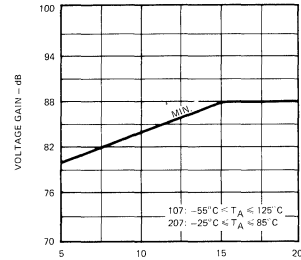

SUPPLY VOLTAGE - +V

GUARANTEED PERFORMANCE CURVES FOR μ A307

INPUT VOLTAGE RANGE AS A FUNCTION OF SUPPLY VOLTAGE

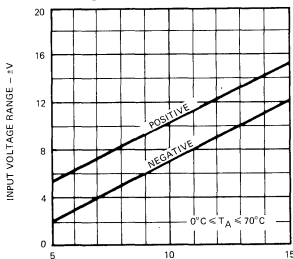

SUPPLY VOLTAGE - +V

OUTPUT SWING AS A FUNCTION OF SUPPLY VOLTAGE

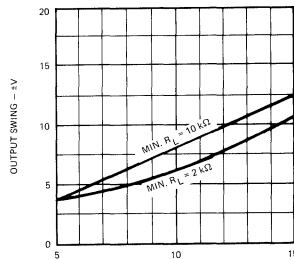

SUPPLY VOLTAGE - +V

VOLTAGE GAIN AS A FUNCTION OF SUPPLY VOLTAGE

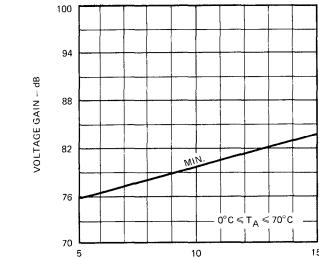

SUPPLY VOLTAGE - +V

TYPICAL PERFORMANCE CURVES FOR μ A107 AND μ A207

VOLTAGE GAIN AS A FUNCTION OF SUPPLY VOLTAGE

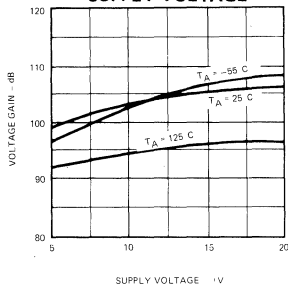

INPUT CURRENT AS A FUNCTION OF SUPPLY VOLTAGE

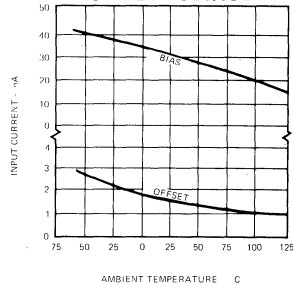

CURRENT LIMITING

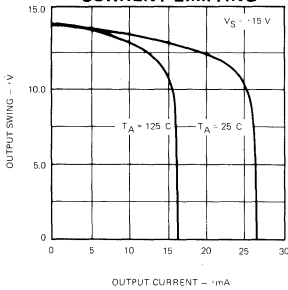

INPUT NOISE CURRENT AS A FUNCTION OF FREQUENCY

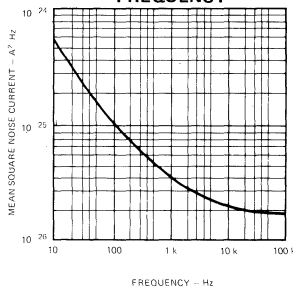

TYPICAL PERFORMANCE CURVES FOR μ A307

VOLTAGE GAIN AS A FUNCTION OF SUPPLY VOLTAGE

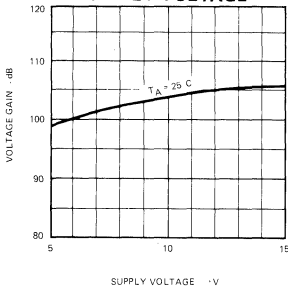

INPUT CURRENT AS A FUNCTION OF AMBIENT TEMPERATURE

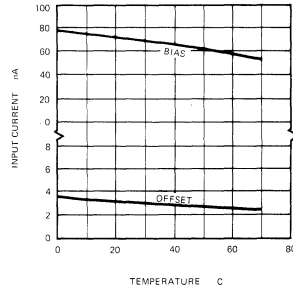

CURRENT LIMITING

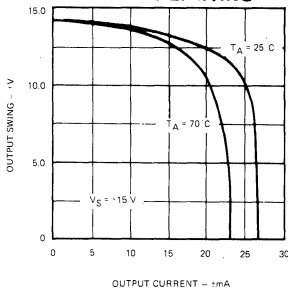

INPUT NOISE CURRENT AS A FUNCTION OF FREQUENCY

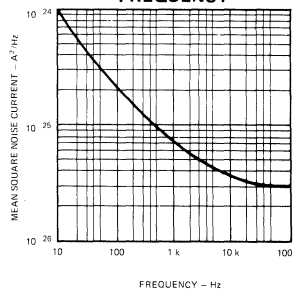

TYPICAL PERFORMANCE CURVES

INPUT NOISE VOLTAGE AS A FUNCTION OF FREQUENCY

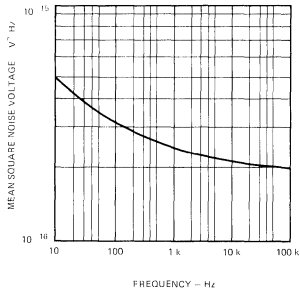

OPEN LOOP FREQUENCY RESPONSE

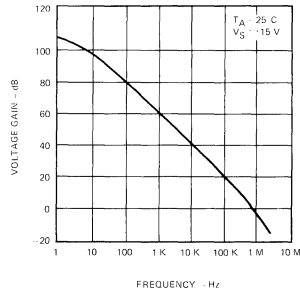

LARGE SIGNAL FREQUENCY RESPONSE

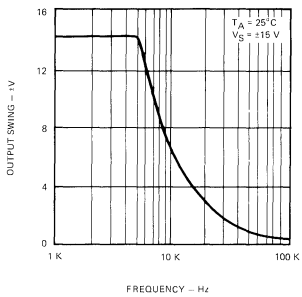

VOLTAGE FOLLOWER PULSE RESPONSE

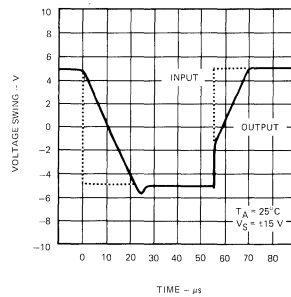

TYPICAL APPLICATIONS

(All pin numbers shown refer to 8-pin TO-5 package)

NON-INVERTING AMPLIFIER

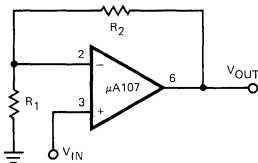

$$V_{OUT} = \frac{R_1 + R_2}{R_1} V_{IN}$$

NON-INVERTING AC AMPLIFIER

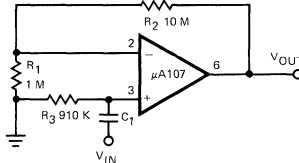

$$V_{OUT} = \frac{R_1 + R_2}{R_1} V_{IN}$$

$$R_{IN} = R_3$$

$$R_3 = R_1 R_2$$

INVERTING AMPLIFIER

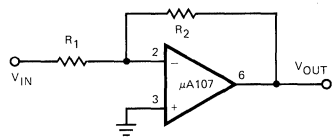

$$V_{OUT} = \frac{R_2}{R_1} V_{IN}$$

$$R_{IN} = R_1$$