

μA101 • μA201

GENERAL PURPOSE OPERATIONAL AMPLIFIERS

FAIRCHILD LINEAR INTEGRATED CIRCUITS

GENERAL DESCRIPTION – The μA101 and μA201 are General Purpose monolithic Operational Amplifiers constructed using the Fairchild Planar* epitaxial process. They are intended for a wide range of analog applications where tailoring of frequency characteristics is desirable. The μA101 and μA201 compensate easily with a single external component. High common mode voltage range and absence of "latch-up" make the μA101 and μA201 ideal for use as voltage followers. The high gain and wide range of operating voltages provide superior performance in integrator, summing amplifier, and general feedback applications. The μA101 and μA201 are short-circuit protected and have the same pin configuration as the popular μA741, μA748 and μA709.

- SHORT-CIRCUIT PROTECTION
- OFFSET VOLTAGE NULL CAPABILITY
- LARGE COMMON-MODE AND DIFFERENTIAL VOLTAGE RANGES
- LOW POWER CONSUMPTION
- NO LATCH-UP

ABSOLUTE MAXIMUM RATINGS

Supply Voltage	±22V
Internal Power Dissipation (Note 1)	
Metal Can	500mW
DIP	670mW
Differential Input Voltage	±30V
Input Voltage (Note 2)	±15V
Storage Temperature Range	
Metal Can, DIP	-65°C to +150°C
Operating Temperature Range (Note 3)	
Military (μA101)	-55°C to +125°C
Commercial (μA201)	0°C to +70°C
Pin Temperature (Soldering, 60 s)	300°C

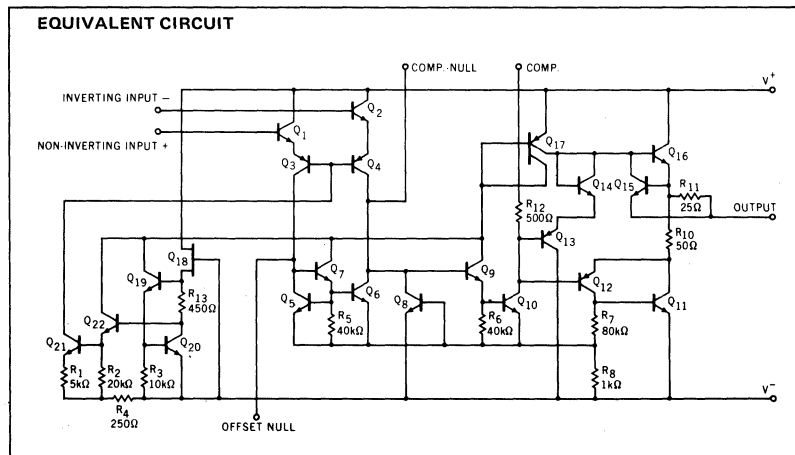

Notes on following pages

CONNECTION DIAGRAMS

8-PIN METAL CAN (TOP VIEW)

PACKAGE OUTLINE 5S
PACKAGE CODE H

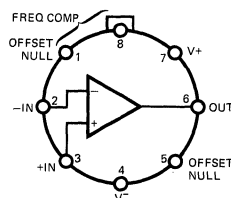

NOTE: Pin 4 connected to case.

ORDER INFORMATION

TYPE	PART NO.
μA101	μA101HM
μA201	μA201HC

14-PIN DIP (TOP VIEW)

PACKAGE OUTLINE 6A
PACKAGE CODE D

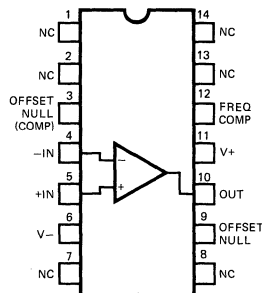

ORDER INFORMATION

TYPE	PART NO.
μA101	μA101DM
μA201	μA201DC

*Planar is a patented Fairchild process.

FAIRCHILD • μ A101 • μ A201

μ A101

ELECTRICAL CHARACTERISTICS: $\pm 5.0\text{ V} \leq V_S \leq \pm 20\text{ V}$, $T_A = 25^\circ\text{C}$, $C_1 = 30\text{ pF}$ unless otherwise specified.

CHARACTERISTICS	CONDITIONS	MIN	TYP	MAX	UNITS
Input Offset Voltage	$R_S \leq 10\text{ k}\Omega$		1.0	5.0	mV
Input Offset Current			40	200	nA
Input Bias Current			120	500	nA
Input Resistance		300	800		k Ω
Supply Current	$V_S = \pm 20\text{V}$		1.8	3.0	mA
Large Signal Voltage Gain	$V_S = \pm 15\text{V}$ $V_{OUT} = \pm 10\text{V}$, $R_L \geq 2\text{ k}\Omega$	50	160		V/mV

The following specifications apply for $-55^\circ\text{C} \leq T_A \leq +125^\circ\text{C}$:

Input Offset Voltage	$R_S \leq 10\text{ k}\Omega$			6.0	mV
Average Temperature Coefficient of Input Offset Voltage	$R_S \leq 50\Omega$		3.0		$\mu\text{V}/^\circ\text{C}$
	$R_S \leq 10\text{ k}\Omega$		6.0		$\mu\text{V}/^\circ\text{C}$
Input Offset Current	$T_A = +125^\circ\text{C}$		10	200	nA
	$T_A = -55^\circ\text{C}$		100	500	nA
Average Temperature Coefficient of Input Offset Current	$+25^\circ\text{C} \leq T_A \leq +125^\circ\text{C}$		0.01	0.1	nA/ $^\circ\text{C}$
	$-55^\circ\text{C} \leq T_A \leq +25^\circ\text{C}$		0.02	0.2	nA/ $^\circ\text{C}$
Input Bias Current	$T_A = -55^\circ\text{C}$		0.28	1.5	μA
Supply Current	$T_A = +125^\circ\text{C}$, $V_S = \pm 20\text{V}$		1.2	2.5	mA
Large Signal Voltage Gain	$V_S = \pm 15\text{V}$, $V_{OUT} = \pm 10\text{V}$ $R_L \geq 2\text{ k}\Omega$	25			V/mV
Output Voltage Swing	$V_S = \pm 15\text{V}$	$R_L = 10\text{ k}\Omega$	± 12	± 14	V
		$R_L = 2\text{ k}\Omega$	± 10	± 13	V
Input Voltage Range	$V_S = \pm 15\text{V}$	± 12			V
Common Mode Rejection Ratio	$R_S \leq 10\text{ k}\Omega$	70	90		dB
Supply Voltage Rejection Ratio	$R_S \leq 10\text{ k}\Omega$	70	90		dB

NOTES

1. Rating applies to ambient temperature up to 70°C . Above 70°C ambient derate linearly at $6.3\text{ mW}/^\circ\text{C}$ for the Metal Can and $8.3\text{ mW}/^\circ\text{C}$ for the DIP.
2. For supply voltages less than $\pm 15\text{V}$, the absolute maximum input voltage is equal to the supply voltage.
3. Short circuit may be to ground or either supply. The 101 ratings apply to $+125^\circ\text{C}$ case temperature or $+75^\circ\text{C}$ ambient temperature. The 201 ratings apply to case temperatures up to $+70^\circ\text{C}$.

5

μ A201

ELECTRICAL CHARACTERISTICS: $\pm 5.0 \text{ V} \leq V_S \leq \pm 15 \text{ V}$, $T_A = 25^\circ\text{C}$, $C_1 = 30 \text{ pF}$ unless otherwise specified.

CHARACTERISTICS	CONDITIONS	MIN	TYP	MAX	UNITS
Input Offset Voltage	$R_S \leq 10 \text{ k}\Omega$		2.0	7.5	mV
Input Offset Current			100	500	nA
Input Bias Current			0.25	1.5	μ A
Input Resistance		100	400		$\text{k}\Omega$
Supply Current	$V_S = \pm 15\text{V}$		1.8	3.0	mA
Large Signal Voltage Gain	$V_S = \pm 15\text{V}$ $V_{OUT} = \pm 10\text{V}$, $R_L \geq 2 \text{ k}\Omega$	20	150		V/mV
The following specifications apply for $0^\circ\text{C} \leq T_A \leq 70^\circ\text{C}$:					
Input Offset Voltage	$R_S \leq 10 \text{ k}\Omega$			10	mV
Average Temperature Coefficient of Input Offset Voltage	$R_S \leq 50\Omega$		6.0		$\mu\text{V}/^\circ\text{C}$
	$R_S \leq 10 \text{ k}\Omega$		10.0		$\mu\text{V}/^\circ\text{C}$
Input Offset Current	$T_A = 70^\circ\text{C}$		50	400	nA
	$T_A = 0^\circ\text{C}$		150	750	nA
Average Temperature Coefficient of Input Offset Current	$25^\circ\text{C} \leq T_A \leq 70^\circ\text{C}$		0.01	0.3	$\text{nA}/^\circ\text{C}$
	$0^\circ\text{C} \leq T_A \leq 25^\circ\text{C}$		0.02	0.6	$\text{nA}/^\circ\text{C}$
Input Bias Current	$T_A = 0^\circ\text{C}$		0.32	2.0	μ A
Large Signal Voltage Gain	$V_S = \pm 15\text{V}$, $V_{OUT} = \pm 10\text{V}$ $R_L \geq 2 \text{ k}\Omega$	15			V/mV
Output Voltage Swing	$V_S = \pm 15\text{V}$				V
	$R_L = 10 \text{ k}\Omega$ $R_L = 2 \text{ k}\Omega$	± 12 ± 10	± 14 ± 13		V
Input Voltage Range	$V_S = \pm 15\text{V}$	± 12			V
Common Mode Rejection Ratio	$R_S \leq 10 \text{ k}\Omega$	65	90		dB
Supply Voltage Rejection Ratio	$R_S \leq 10 \text{ k}\Omega$	70	90		dB