

μ A124 • μ A224 • μ A324 • μ A2902

QUAD OPERATIONAL AMPLIFIERS

FAIRCHILD LINEAR INTEGRATED CIRCUITS

GENERAL DESCRIPTION — The μ A124 series of Quad Operational Amplifiers consists of four independent high gain, internally frequency compensated operational amplifiers designed to operate from a single power supply or dual power supplies over a wide range of voltages. The common mode input range includes the negative supply, thereby eliminating the necessity for external biasing components in many applications. The output voltage range also includes the negative power supply voltage. They are constructed using the Fairchild Planar* epitaxial process.

- INPUT COMMON MODE VOLTAGE RANGE INCLUDES GROUND OR NEGATIVE SUPPLY
- OUTPUT VOLTAGE CAN SWING TO GROUND OR NEGATIVE SUPPLY
- FOUR INTERNALLY COMPENSATED OPERATIONAL AMPLIFIERS IN A SINGLE PACKAGE
- WIDE POWER SUPPLY RANGE: SINGLE OF 3.0 V TO 30 V
DUAL SUPPLY OF ± 1.5 V TO ± 16 V
- POWER DRAIN SUITABLE FOR BATTERY OPERATION

ABSOLUTE MAXIMUM RATINGS

Supply Voltage Between V+ and V-	32
Differential Input Voltage (Note 1)	32
Input Voltage (V-) (Note 1)	-0.3V (V-) to V+
Internal Power Dissipation (Note 2)	670 mW
Operating Temperature Range — μ A124	-55°C to +125°C
μ A224	-25°C to +85°C
μ A324	0°C to +70°C
μ A2902	-40°C to +85°C
Storage Temperature Range	
Molded Package	-55°C to +125°C
Hermetic Package	-65°C to +150°C
Pin Temperature	
Molded Package (Soldering, 10 s)	260°C
Hermetic Package (Soldering, 60 s)	300°C

CONNECTION DIAGRAM 14-PIN DIP (TOP VIEW)

PACKAGE OUTLINES 6A 9A
PACKAGE CODES D P

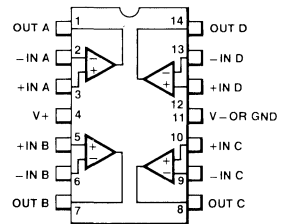

5

ORDER INFORMATION

TYPE	PART NO.
μ A124	μ A124DM
μ A224	μ A224DM
μ A324	μ A324DC
μ A324	μ A324PC
μ A2902	μ A2902PC

1/4 EQUIVALENT CIRCUIT

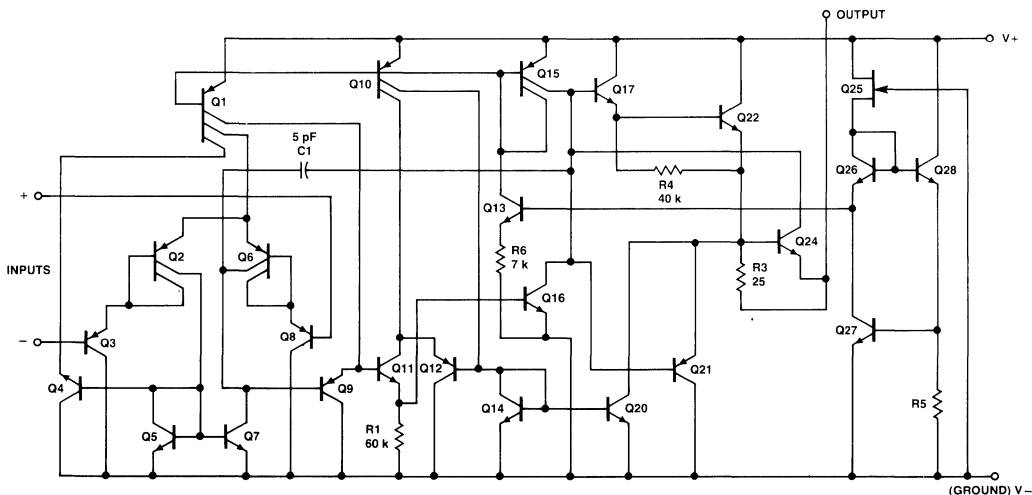

μ A124 • μ A224

ELECTRICAL CHARACTERISTICS: $V_+ = 5.0$ Vdc, $T_A = 25^\circ\text{C}$ unless otherwise specified.

CHARACTERISTICS		CONDITIONS	MIN	TYP	MAX	UNITS
Input Offset Voltage		(Note 5)		2.0	5.0	mV
Input Offset Current				3.0	30	nA
Input Bias Current				-45	-150	nA
Input Common Mode Voltage Range			0		$V_+ - 1.5$ V	V
Common Mode Rejection Ratio		$R_S \leq 10$ k Ω	70	85		dB
Large Signal Open Loop Voltage Gain		$V_+ = +15$ V, $R_L = 2$ k Ω	50	100		V/mV
Output Current	Source	$V_{IN+} = +1$ Vdc, $V_{IN-} = 0$ $V_+ = +15$ V	20	40		mA
	Sink	$V_{IN-} = +1$ Vdc $V_{IN+} = 0$ $V_+ = +15$ Vdc	10	20		mA
	Sink	$V_{IN-} = +1$ Vdc, $V_{IN+} = 0$ $V_{OUT} = 200$ mV	12	50		μ A
Power Supply Rejection Ratio			65	100		dB
Channel Separation		$f = 1$ kHz to 20 kHz		-120		dB
Short Circuit Current		To ground		40	60	mA

The following specifications apply for $-55^\circ\text{C} \leq T_A \leq +125^\circ\text{C}$ for μ A124 and -25°C to $+85^\circ\text{C}$ for μ A224

Input Offset Voltage		(Note 5)			7	mV
Average Temperature Coefficient of Input Offset Voltage		$R_S = 0$		7		$\mu\text{V}/^\circ\text{C}$
Input Offset Current					± 100	nA
Average Temperature Coefficient of Input Offset Current				10		$\text{pA}/^\circ\text{C}$
Input Bias Current				-40	-300	nA
Large Signal Open Loop Voltage Gain		$R_L = 2$ k Ω , $V_+ = +15$ V	25			V/mV
Output Voltage Range	V_{OH}	$V_+ = +30$ Vdc, $R_L = 2$ k Ω	26			V
	V_{OH}	$V_+ = +30$ Vdc, $R_L \geq 10$ k Ω	27	28		V
	V_{OL}	$V_+ = 5$ Vdc, $R_L \leq 10$ k Ω		5	20	mV
Input Common Mode Voltage Range		$V_+ = +30$ Vdc	0		$V_+ - 2.0$	V
Output Current	Source	$V_{IN+} = +1$ V $V_{IN-} = 0$, $V_+ = 15$ V	10	20		mA
	Sink	$V_{IN-} = +1$ V $V_{IN+} = 0$, $V_+ = 15$ V	5	8		mA
Differential Input Voltage					V_+	V
Supply Current	$R_L = \infty$, $V_{CC} = 30$ V			1.5	3.0	mA
	$R_L = \infty$, $V_{CC} = +5$ V			0.7	1.2	mA

NOTES:

1. For supply voltage less than 30 V between V_+ and V_- , the absolute maximum input voltage is equal to the supply voltage.
2. Rating applies to ambient temperature up to 70°C . Above $T_A = 70^\circ\text{C}$, derate linearly at 8.3 mW/ $^\circ\text{C}$.
3. Not to exceed maximum package power dissipation.
4. Output will swing to ground.
5. $V_{OUT} = 1.4$ Vdc, $R_S = 0$ Ω with V_+ from 5 Vdc to +30 Vdc; and over the full input common mode range (0 to $V_+ - 2.0$ Vdc) except at 25°C , where common mode range is 0 Vdc to $V_+ - 1.5$ Vdc.

μ A324

ELECTRICAL CHARACTERISTICS: $V_+ = 5.0$ Vdc, $T_A = 25^\circ\text{C}$ unless otherwise specified.

CHARACTERISTICS		CONDITIONS	MIN	TYP	MAX	UNITS
Input Offset Voltage		(Note 5)		2.0	7.0	mV
Input Offset Current				5.0	50	nA
Input Bias Current				-45	-250	nA
Input Common Mode Voltage Range			0		$V_+ - 1.5$ V	V
Common Mode Rejection Ratio		$R_S \leq 10$ k Ω	65	70		dB
Large Signal Open Loop Voltage Gain		$V_+ = +15$ V, $R_L = 2$ k Ω	25	100		V/mV
Output Current	Source	$V_{IN+} = +1$ Vdc, $V_{IN-} = 0$ $V_+ = +15$ V	20	40		mA
	Sink	$V_{IN-} = +1$ Vdc $V_{IN+} = 0$ $V_+ = +15$ Vdc	10	20		mA
	Sink	$V_{IN-} = +1$ Vdc, $V_{IN+} = 0$ $V_{OUT} = 200$ mV	12	50		μ A
Power Supply Rejection Ratio			65	100		dB
Channel Separation		$f = 1$ kHz to 20 kHz		-120		dB
Short Circuit Current		To ground		40	60	mA

The following specifications apply for 0°C to $+70^\circ\text{C}$

Input Offset Voltage		(Note 5)			9	mV
Average Temperature Coefficient of Input Offset Voltage		$R_S = 0$		7		$\mu\text{V}/^\circ\text{C}$
Input Offset Current				± 100	± 150	nA
Average Temperature Coefficient of Input Offset Current				10		$\text{pA}/^\circ\text{C}$
Input Bias Current				-40	-500	nA
Large Signal Open Loop Voltage Gain		$R_L = 2$ k Ω , $V_+ = +15$ V	15			V/mV
Output Voltage Range	V_{OH}	$V_+ = +30$ Vdc, $R_L = 2$ k Ω	26			V
	V_{OH}	$V_+ = +30$ Vdc, $R_L \geq 10$ k Ω	27	28		V
	V_{OL}	$V_+ = 5$ Vdc, $R_L \leq 10$ k Ω		5	20	mV
Input Common Mode Voltage Range		$V_+ = +30$ Vdc	0		$V_+ - 2.0$	V
Output Current	Source	$V_{IN+} = +1$ V $V_{IN-} = 0$, $V_+ = 15$ V	10	20		mA
	Sink	$V_{IN-} = +1$ V $V_{IN+} = 0$, $V_+ = 15$ V	5	8		mA
Differential Input Voltage					V_+	V
Supply Current		$R_L = \infty$, $V_{CC} = 30$ V		1.5	3.0	mA
		$R_L = \infty$, $V_{CC} = +5$ V		0.7	1.2	mA

NOTES:

1. For supply voltage less than 30 V between V_+ and V_- , the absolute maximum input voltage is equal to the supply voltage.
2. Rating applies to ambient temperature up to 70°C . Above $T_A = 70^\circ\text{C}$, derate linearly at 8.3 mW/ $^\circ\text{C}$.
3. Not to exceed maximum package power dissipation.
4. Output will swing to ground.
5. $V_{OUT} = 1.4$ Vdc, $R_S = 0$ Ω with V_+ from 5 Vdc to +30 Vdc; and over the full input common mode range (0 to $V_+ - 2.0$ Vdc) except at 25°C , where common mode range is 0 Vdc to $V_+ - 1.5$ Vdc.

5

μ A2902

ELECTRICAL CHARACTERISTICS: $V_+ = 5.0$ Vdc, $T_A = 25^\circ\text{C}$ unless otherwise specified.

CHARACTERISTICS		CONDITIONS	MIN	TYP	MAX	UNITS
Input Offset Voltage		(Note 5)		2.0	7.0	mV
Input Offset Current				5.0	50	nA
Input Bias Current				-45	-250	nA
Input Common Mode Voltage Range			0		$V_+ - 1.5$ V	V
Common Mode Rejection Ratio		$R_S \leq 10$ k Ω	50	70		dB
Large Signal Open Loop Voltage Gain		$V_+ = +15$ V, $R_L = 2$ k Ω		100		V/mV
Output Current	Source	$V_{IN+} = +1$ Vdc, $V_{IN-} = 0$ $V_+ = +15$ V	20	40		mA
	Sink	$V_{IN-} = +1$ Vdc $V_{IN+} = 0$ $V_+ = +15$ Vdc	10	20		mA
Power Supply Current		$R_L = \infty$			3.0	mA
Power Supply Rejection Ratio			50	100		dB
Short Circuit Current		To ground		40	60	mA
Channel Separation		$f = 1$ kHz to 20 kHz		-120		dB

The following specifications apply for -40°C to $+85^\circ\text{C}$

Input Offset Voltage		(Note 5)			10	mV
Average Temperature Coefficient of Input Offset Voltage		$R_S = 0$		7		$\mu\text{V}/^\circ\text{C}$
Input Offset Current				± 45	± 200	nA
Average Temperature Coefficient of Input Offset Current				10		$\text{pA}/^\circ\text{C}$
Input Bias Current				-40	-500	nA
Large Signal Open Loop Voltage Gain		$R_L = 2$ k Ω , $V_+ = +15$ V	15			V/mV
Output Voltage Range	V_{OH}	$V_+ = +30$ Vdc, $R_L = 2$ k Ω	22			V
	V_{OH}	$V_+ = +30$ Vdc, $R_L \geq 10$ k Ω	23	24		V
	V_{OL}	$V_+ = 5$ Vdc, $R_L \leq 10$ k Ω		5	100	mV
Input Common Mode Voltage Range		$V_+ = +30$ Vdc	0		$V_+ - 2.0$	V
Output Current	Source	$V_{IN+} = +1$ V $V_{IN-} = 0$, $V_+ = 15$ V	10	20		mA
	Sink	$V_{IN-} = +1$ V $V_{IN+} = 0$, $V_+ = 15$ V	5	8		mA
Differential Input Voltage					V_+	V

NOTES:

1. For supply voltage less than 30 V between V_+ and V_- , the absolute maximum input voltage is equal to the supply voltage.
2. Rating applies to ambient temperature up to 70°C . Above $T_A = 70^\circ\text{C}$, derate linearly at 8.3 mW/ $^\circ\text{C}$.
3. Not to exceed maximum package power dissipation.
4. Output will swing to ground.
5. $V_{OUT} = 1.4$ Vdc, $R_S = 0$ Ω with V_+ from 5 Vdc to +30 Vdc; and over the full input common mode range (0 to $V_+ - 2.0$ Vdc) except at 25°C , where common mode range is 0 Vdc to $V_+ - 1.5$ Vdc.

TYPICAL PERFORMANCE CURVES

LARGE SIGNAL OPEN LOOP VOLTAGE GAIN AS A FUNCTION OF FREQUENCY

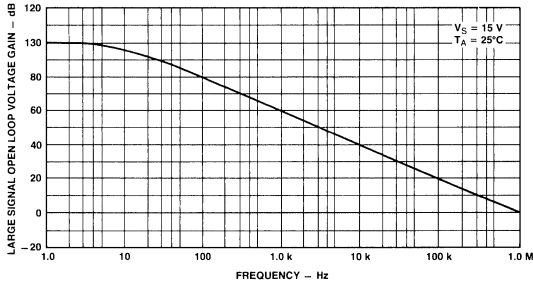

OUTPUT CHARACTERISTICS CURRENT SOURCING

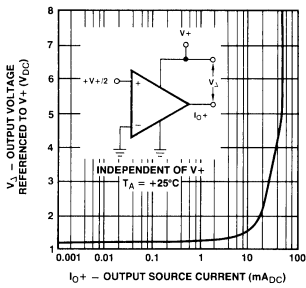

OUTPUT CHARACTERISTICS CURRENT SINKING

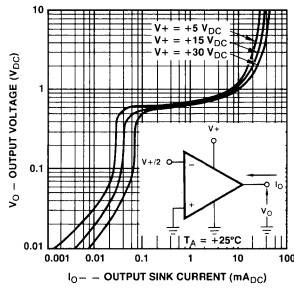

OUTPUT VOLTAGE AS A FUNCTION OF FREQUENCY

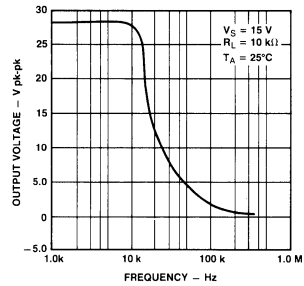

OUTPUT SWING AS A FUNCTION OF SUPPLY VOLTAGE

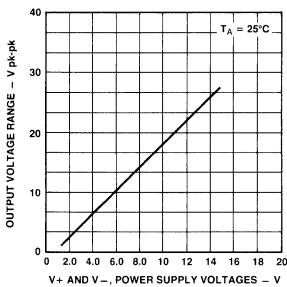

INPUT BIAS CURRENT AS A FUNCTION OF TEMPERATURE

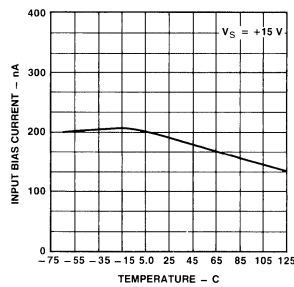

INPUT BIAS CURRENT AS A FUNCTION OF SUPPLY VOLTAGE

