

μA3303 • μA3403 • μA3503

QUAD OPERATIONAL AMPLIFIERS

FAIRCHILD LINEAR INTEGRATED CIRCUITS

GENERAL DESCRIPTION — The μA3303, μA3403 and μA3503 are monolithic Quad Operational Amplifiers consisting of four independent high-gain, internally frequency-compensated operational amplifiers designed to operate from a single power supply or dual power supplies over a wide range of voltages. The common mode input range includes the negative supply, thereby eliminating the necessity for external biasing components in many applications. They are constructed using the Fairchild Planar* epitaxial process.

- INPUT COMMON MODE VOLTAGE RANGE INCLUDES GROUND OR NEGATIVE SUPPLY
- OUTPUT VOLTAGE CAN SWING TO GROUND OR NEGATIVE SUPPLY
- FOUR INTERNALLY COMPENSATED OPERATIONAL AMPLIFIERS IN A SINGLE PACKAGE
- WIDE POWER SUPPLY RANGE: SINGLE SUPPLY OF 3.0 TO 36 V
DUAL SUPPLY OF ±1.5 TO ±18 V
- CLASS AB OUTPUT STAGE FOR MINIMAL CROSSOVER DISTORTION
- SHORT CIRCUIT PROTECTED OUTPUTS
- HIGH OPEN LOOP GAIN — 200 k
- μA741 OPERATIONAL AMPLIFIER TYPE PERFORMANCE

ABSOLUTE MAXIMUM RATINGS

Supply Voltage Between V+ and V-
Differential Input Voltage (Note 1)
Input Voltage (V-) (Note 1)
Internal Power Dissipation (Note 2)
Operating Temperature Range

μA3303
μA3403
μA3503

36 V
±30 V
-0.3 V(V-) to V+
670 mW
-40°C to +85°C
0°C to +70°C
-55°C to +125°C

Storage Temperature Range

Molded Package
Hermetic Package
Pin Temperature

Molded Package (Soldering, 10 s)
Hermetic Package (Soldering, 60 s)

-55°C to +125°C
-65°C to +150°C
260°C
300°C

CONNECTION DIAGRAM
14-PIN DIP
(TOP VIEW)

PACKAGE OUTLINES 6A 9A
PACKAGE CODES D P

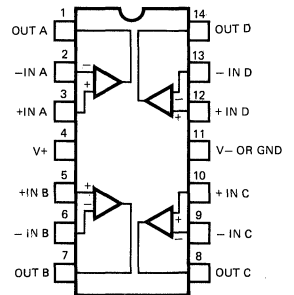

ORDER INFORMATION

TYPE	PART NO.
μA3303	μA3303PC
μA3403	μA3403PC
μA3403	μA3403DC
μA3503	μA3503DC

1/4 OF EQUIVALENT CIRCUIT

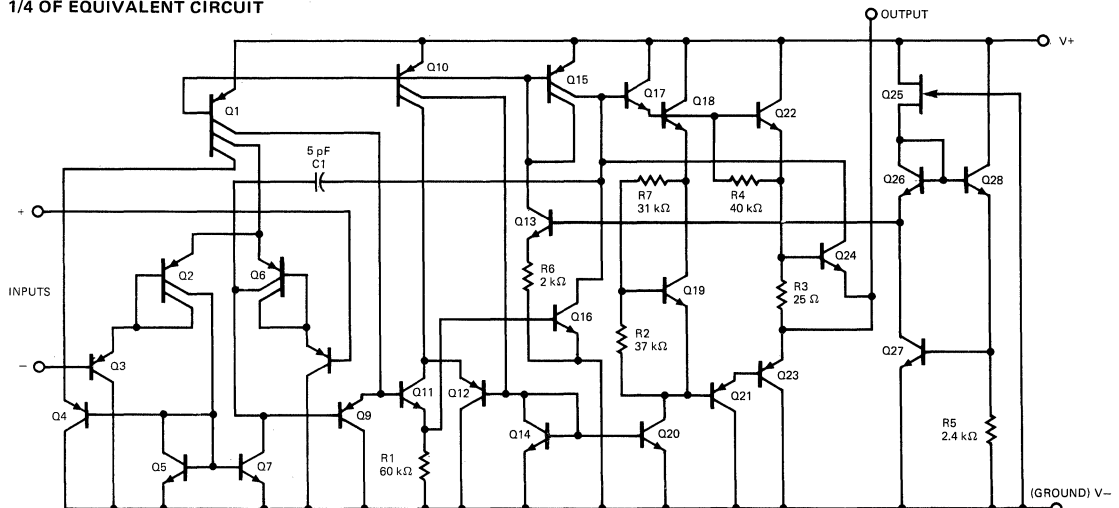

*Planar is a patented Fairchild process.

μ A3303

ELECTRICAL CHARACTERISTICS: $V_+ = +14$ V, $V_- = \text{Gnd}$, $T_A = 25^\circ\text{C}$ unless otherwise noted.

CHARACTERISTICS	CONDITION	MIN	TYP	MAX	UNITS
Input Offset Voltage			2.0	8.0	mV
Input Offset Current			30	75	nA
Input Bias Current			200	-500	nA
Input Impedance	$f = 20$ Hz	0.3	1.0		M Ω
Input Common Mode Voltage Range		+12 to Gnd	+12.5 to Gnd		V
Common Mode Rejection Ratio	$R_S \leq 10$ k Ω	70	90		dB
Large Signal Open-Loop Voltage Gain	$R_L = 2$ k Ω	20	200		V/mV
Power Bandwidth	$A_V = 1$, $R_L = 2$ k Ω , $V_{OUT} = 10$ V pk-pk THD = 5%		18		kHz
Small Signal Bandwidth	$A_V = 1$, $R_L = 10$ k Ω , $V_{OUT} = 50$ mV		1.0		MHz
Slew Rate	$A_V = 1$		0.6		V/ μ s
Rise Time	$A_V = 1$, $R_L = 10$ k Ω , $V_{OUT} = 50$ mV		0.3		μ s
Fall Time	$A_V = 1$, $R_L = 10$ k Ω , $V_{OUT} = 50$ mV		0.3		μ s
Overshoot	$A_V = 1$, $R_L = 10$ k Ω , $V_{OUT} = 50$ mV		5.0		%
Phase Margin	$A_V = 1$, $R_L = 2$ k Ω , $C_L = 200$ pF		60		Degree
Crossover Distortion	$V_{IN} = 30$ mV pk-pk, $V_{OUT} = 2$ V pk-pk $f = 10$ kHz		1.0		%
Output Voltage Range	$R_L = 10$ k Ω $R_L = 2$ k Ω	12 10	12.5 12		V V
Individual Output Short Circuit Current		± 10	± 30	± 45	mA
Output Impedance	$f = 20$ Hz		800		Ω
Power Supply Rejection Ratio			30	150	μ V/V
Power Supply Current	$V_{OUT} = 0$, $R_L = \infty$		2.8	7.0	mA

The following specification apply for $-40^\circ\text{C} \leq T_A \leq 85^\circ\text{C}$

Input Offset Voltage				10	mV
Average Temperature Coefficient of Input Offset Voltage			10		$\mu\text{V}/^\circ\text{C}$
Input Offset Current				250	nA
Average Temperature Coefficient of Input Offset Current			50		$\text{pA}/^\circ\text{C}$
Input Bias Current				-1000	nA
Large Signal Open Loop Voltage Gain	$R_L = 2$ k Ω	15			V/mV
Output Voltage Range	$R_L = 2$ k Ω	+10			V

ELECTRICAL CHARACTERISTICS: $V_{S+} = +5.0$ V, $V_{S-} = \text{G}$, $T_A = 25^\circ\text{C}$ unless otherwise noted.

CHARACTERISTICS	CONDITION	MIN	TYP	MAX	UNITS
Input Offset Voltage				10	mV
Input Offset Current				75	nA
Input Bias Current				-500	nA
Large Signal Open Loop Voltage Gain	$R_L = 2$ k Ω	20	200		V/mV
Power Supply Rejection Ratio				150	$\mu\text{V}/\text{V}$
Output Voltage Range	$R_L = 10$ k Ω $R_L = 10$ k Ω , 5.0 V $\leq V_S \leq 30$ V	3.5 (V+)-1.7			V pk-pk V pk-pk
Power Supply Current			2.5	7.0	mA
Channel Separation	$f = 1$ kHz to 20 kHz (Input Referenced)		-120		dB

μ A3403

ELECTRICAL CHARACTERISTICS: $V_S = \pm 15$ V, $T_A = 25^\circ$ C unless otherwise noted.

CHARACTERISTICS	CONDITION	MIN	TYP	MAX	UNITS
Input Offset Voltage			2.0	8.0	mV
Input Offset Current			30	50	nA
Input Bias Current			-200	-500	nA
Input Impedance	$f = 20$ Hz	0.3	1.0		M Ω
Input Common Mode Voltage Range		+13 to $-V_S$	+13.5 to $-V_S$		V
Common Mode Rejection Ratio	$R_S \leq 10$ k Ω	70	90		dB
Large Signal Open Loop Voltage Gain	$V_{OUT} = \pm 10$ V, $R_L = 2$ k Ω	20	200		V/mV
Power Bandwidth	$A_V = 1$, $R_L = 2$ k Ω , $V_{OUT} = 20$ V pk-pk THD = 5%		9.0		kHz
Small Signal Bandwidth	$A_V = 1$, $R_L = 10$ k Ω , $V_{OUT} = 50$ mV		1.0		MHz
Slew Rate	$A_V = 1$, $V_{IN} = -10$ V to +10 V		0.6		V/ μ s
Rise Time	$A_V = 1$, $R_L = 10$ k Ω , $V_{OUT} = 50$ mV		0.3		μ s
Fall Time	$A_V = 1$, $R_L = 10$ k Ω , $V_{OUT} = 50$ mV		0.3		μ s
Overshoot	$A_V = 1$, $R_L = 10$ k Ω , $V_{OUT} = 50$ mV		5.0		%
Phase Margin	$A_V = 1$, $R_L = 2$ k Ω , $C_L = 200$ pF		60		Degree
Crossover Distortion	$V_{IN} = 30$ mV pk-pk, $V_{OUT} = 2$ V pk-pk $f = 10$ kHz		1.0		%
Output Voltage Range	$R_L = 10$ k Ω $R_L = 2$ k Ω	± 12 ± 10	± 13.5 ± 13		V V
Individual Output Short Circuit Current		± 10	± 30	± 45	mA
Output Impedance	$f = 20$ Hz		80		Ω
Power Supply Rejection Ratio	Positive Negative		30 30	150 150	μ V/V μ V/V
Power Supply Current	$V_{OUT} = 0$, $R_L = \infty$		2.8	7.0	mA
The following specification apply for 0° C $\leq T_A \leq 70^\circ$ C					
Input Offset Voltage				10	mV
Average Temperature Coefficient of Input Offset Voltage			10		μ V/ $^\circ$ C
Input Offset Current				200	nA
Average Temperature Coefficient of Input Offset Current			50		pA/ $^\circ$ C
Input Bias Current				-800	nA
Large Signal Open Loop Voltage Gain	$R_L = 2$ k Ω , $V_{OUT} = \pm 10$ V	15			V/mV
Output Voltage Range	$R_L = 2$ k Ω	± 10			V

ELECTRICAL CHARACTERISTICS: $V_{S+} = +5.0$ V, $V_{S-} = G$, $T_A = 25^\circ$ C unless otherwise noted.

CHARACTERISTICS	CONDITION	MIN	TYP	MAX	UNITS
Input Offset Voltage			2.0	10	mV
Input Offset Current			30	50	nA
Input Bias Current			-200	-500	nA
Large Signal Open Loop Voltage Gain	$R_L = 2$ k Ω	20	200		V/mV
Power Supply Rejection Ratio				150	μ V/V
Output Voltage Range	$R_L = 10$ k Ω $R_L = 10$ k Ω , 5.0 V $\leq V_S \leq 30$ V	3.5 (V+) -1.7			V pk-pk V pk-pk
Power Supply Current			2.5	7.0	mA
Channel Separation	$f = 1$ kHz to 20 kHz (Input Referenced)		-120		dB

μ A3503

ELECTRICAL CHARACTERISTICS: $V_S = \pm 15$ V, $T_A = 25^\circ\text{C}$ unless otherwise noted.

CHARACTERISTICS	CONDITION	MIN	TYP	MAX	UNITS
Input Offset Voltage			2.0	5.0	mV
Input Offset Current			30	50	nA
Input Bias Current			-200	-500	nA
Input Impedance	$f = 20$ Hz	0.3	1.0		$M\Omega$
Input Common Mode Voltage Range		+13 to $-V_S$	+13.5 to $-V_S$		V
Common Mode Rejection Ratio	$R_S \leq 10$ k Ω	70	90		dB
Large Signal Open Loop Voltage Gain	$V_{OUT} = \pm 10$ V, $R_L = 2$ k Ω	50	200		V/mV
Power Bandwidth	$A_V = 1$, $R_L = 2$ k Ω , $V_{OUT} = 20$ V pk-pk		9.0		kHz
Small Signal Bandwidth	$A_V = 1$, $R_L = 10$ k Ω , $V_{OUT} = 50$ mV		1.0		MHz
Slew Rate	$A_V = 1$, $V_{IN} = -10$ V to +10 V		0.6		V/ μ s
Rise Time	$A_V = 1$, $R_L = 10$ k Ω , $V_{OUT} = 50$ mV		0.3		μ s
Fall Time	$A_V = 1$, $R_L = 10$ k Ω , $V_{OUT} = 50$ mV		0.3		μ s
Overshoot	$A_V = 1$, $R_L = 10$ k Ω , $V_{OUT} = 50$ mV		5.0		%
Phase Margin	$A_V = 1$, $R_L = 2$ k Ω , $C_L = 200$ pF		60		Degree
Crossover Distortion at $f = 10$ kHz	$V_{IN} = 30$ mV pk-pk, $V_{OUT} = 2$ V pk-pk		1.0		%
Output Voltage Range	$R_L = 10$ k Ω $R_L = 2$ k Ω	± 12 ± 10	± 13.5 ± 13		V
Individual Output Short Circuit Current	(Note 3)	± 20	± 30	± 45	mA
Output Impedance	$f = 20$ Hz		80		Ω
Power Supply Rejection Ratio	Positive Negative		30 30	150 150	μ V/V μ V/V
Power Supply Current	$V_{OUT} = 0$, $R_L = \infty$		2.8	4.0	mA

The following specifications apply for $-55^\circ\text{C} \leq T_A \leq +125^\circ\text{C}$

Input Offset Voltage				6.0	mV
Average Temperature Coefficient of Input Offset Voltage			10		μ V/ $^\circ\text{C}$
Input Offset Current				200	nA
Average Temperature Coefficient of Input Offset Current			50		μ A/ $^\circ\text{C}$
Input Bias Current			-300	-1500	nA
Large Signal Open Loop Voltage Gain	$R_L = 2$ k Ω , $V_{OUT} = \pm 10$ V	25	300		V/mV
Output Voltage Range	$R_L = 2$ k Ω	± 10			V

ELECTRICAL CHARACTERISTICS: $V_S = +5.0$ V, $V_{S-} = G$, $T_A = 25^\circ\text{C}$ unless otherwise noted.

CHARACTERISTICS	CONDITION	MIN	TYP	MAX	UNITS
Input Offset Voltage			2.0	5.0	mV
Input Offset Current			30	50	nA
Input Bias Current			-200	-500	nA
Large Signal Open Loop Voltage Gain	$R_L = 2$ k Ω	20	200		V/mV
Power Supply Rejection Ratio				150	μ V/V
Output Voltage Range (Note 4)	$R_L = 10$ k Ω $R_L = 10$ k Ω , 5.0 V $\leq V_S \leq 30$ V	3.5 (V+) - 1.7			V pk-pk V pk-pk
Power Supply Current			2.5	4.0	mA
Channel Separation	$f = 1$ kHz to 20 kHz (Input Referenced)		-120		dB

NOTES:

- For supply voltage less than 30 V between $V+$ and $V-$, the absolute maximum input voltage is equal to the supply voltage.
- Rating applies to ambient temperature up to 70°C . Above $T_A = 70^\circ\text{C}$, derate linearly at 8.3 mW/ $^\circ\text{C}$.
- Not to exceed maximum package power dissipation.
- Output will swing to ground.

TYPICAL PERFORMANCE CURVES

LARGE SIGNAL OPEN LOOP VOLTAGE GAIN AS A FUNCTION OF FREQUENCY

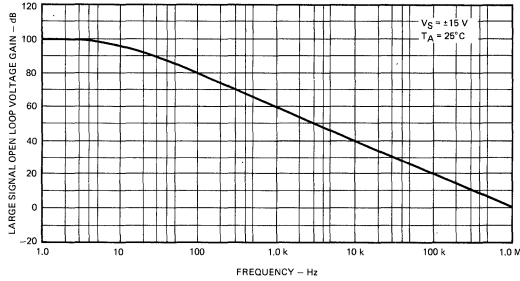

SINE WAVE RESPONSE

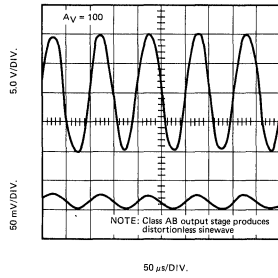

OUTPUT VOLTAGE AS A FUNCTION OF FREQUENCY

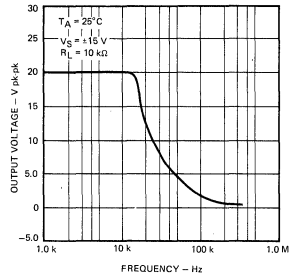

OUTPUT SWING AS A FUNCTION OF SUPPLY VOLTAGE

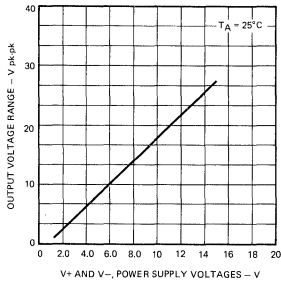

INPUT BIAS CURRENT AS A FUNCTION OF TEMPERATURE

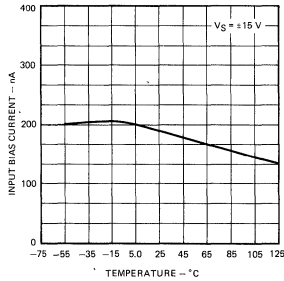

INPUT BIAS CURRENT AS A FUNCTION OF SUPPLY VOLTAGE

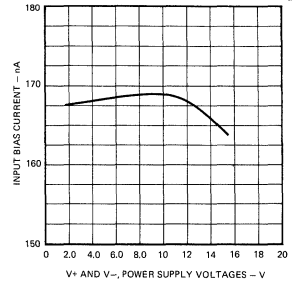

TYPICAL APPLICATIONS

MULTIPLE FEEDBACK BANDPASS FILTER

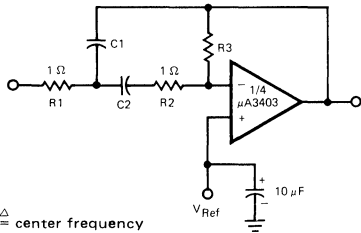

$f_o \Delta$ = center frequency

BW Δ = Bandwidth

R in k Ω

C in μ F

$$Q = \frac{f_o}{BW} < 10$$

$$C1 = C2 = \frac{Q}{3}$$

$$R1 = R2 = 1$$

$$R3 = 9Q^2 - 1$$

Design example:

given: $Q = 5, f_o = 1$ kHz

Let $R1 = R2 = 10$ k Ω

then $R3 = 9(5)^2 - 10$

$R3 = 215$ k Ω

$C = \frac{5}{3} = 1.6$ nF

} Use scaling factors in these expressions.

If source impedance is high or varies, filter may be preceded with voltage follower buffer to stabilize filter parameters.

WEIN BRIDGE OSCILLATOR

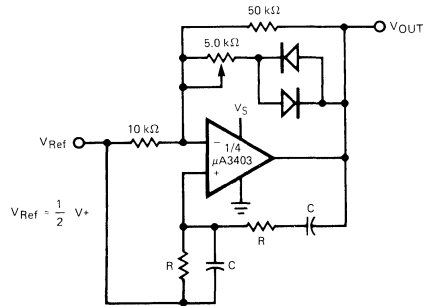

$$f_o = \frac{1}{2\pi RC} \quad \text{for } f_o = 1 \text{ kHz}$$

$$R = 16 \text{ k}\Omega$$

$$C = 0.01 \mu\text{F}$$

HIGH IMPEDANCE DIFFERENTIAL AMPLIFIER

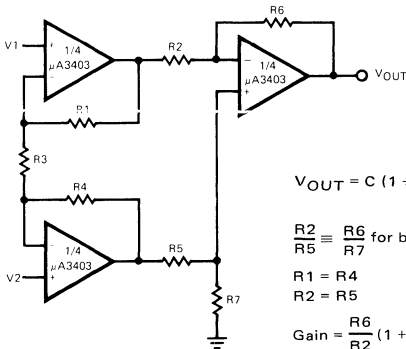

$$V_{OUT} = C(1 + a + b)(V2 - V1)$$

$$\frac{R2}{R5} \cong \frac{R6}{R7} \text{ for best CMRR}$$

$$R1 = R4$$

$$R2 = R5$$

$$\text{Gain} = \frac{R6}{R2} \left(1 + \frac{2R1}{R3}\right) = C(1 + a + b)$$

COMPARATOR WITH HYSTERESIS

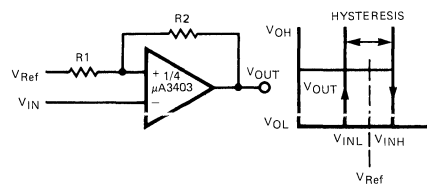

$$V_{INL} = \frac{R1}{R1 + R2} (V_{OL} - V_{Ref}) + V_{Ref}$$

$$V_{INH} = \frac{R1}{R1 + R2} (V_{OH} - V_{Ref}) + V_{Ref}$$

$$H = \frac{R1}{R1 + R2} (V_{OH} - V_{OL})$$

BI-QUAD FILTER

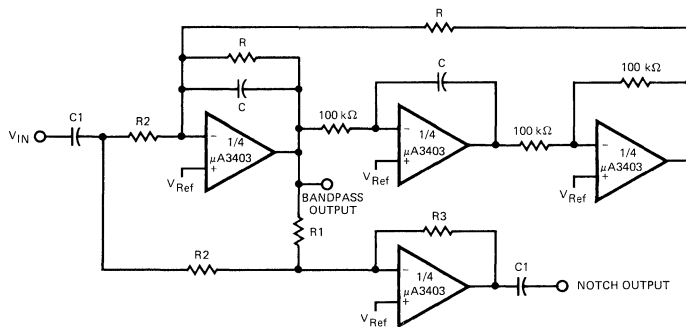

$$Q = \frac{f_o}{BW}$$

where

T_{BP} = Center Frequency Gain

T_N = Bandpass Notch Gain

$$f_o = \frac{1}{2\pi RC}$$

$$R1 = QR$$

$$R2 = \frac{R1}{T_{BP}}$$

$$R3 = T_N R2$$

$$C1 = 10C$$

Example:

$f_o = 1000$ Hz

$BW = 100$ Hz

$T_{BP} = 1$

$T_N = 1$

$R = 160$ k Ω

$R1 = 1.6$ M Ω

$R2 = 1.6$ M Ω

$R3 = 1.6$ M Ω

$C = 0.001$ μ F

TYPICAL APPLICATIONS (Cont'd)

PULSE GENERATOR

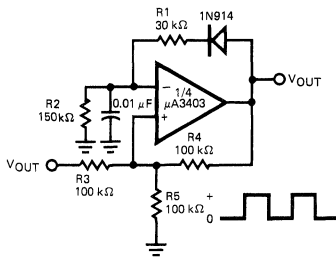

FUNCTION GENERATOR

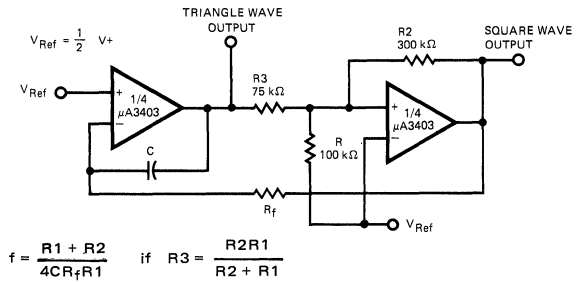

VOLTAGE REFERENCE

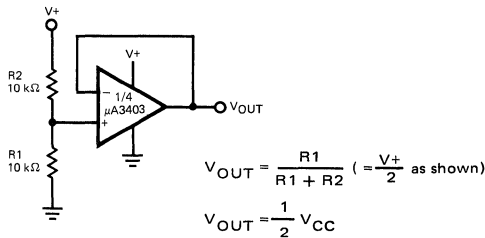

GROUND REFERENCING A DIFFERENTIAL INPUT SIGNAL

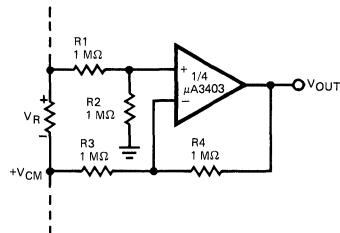

VOLTAGE CONTROLLED OSCILLATOR

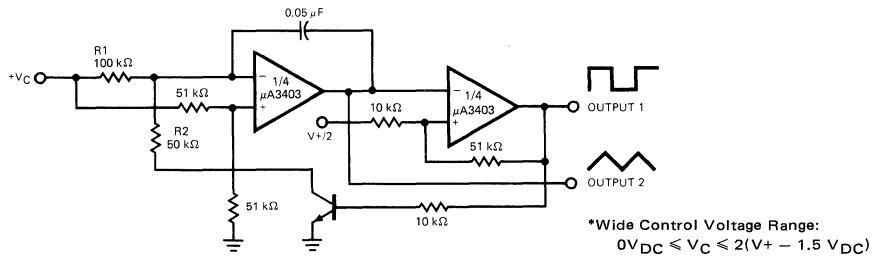

AC COUPLED NON-INVERTING AMPLIFIER

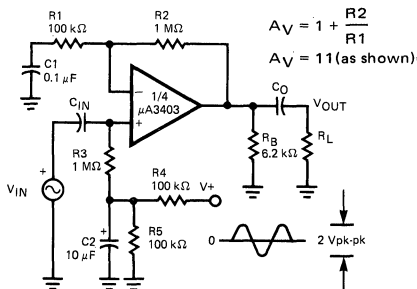

AC COUPLED INVERTING AMPLIFIER

