

μ A4151 • μ A7151

VOLTAGE-TO-FREQUENCY CONVERTER

FAIRCHILD LINEAR INTEGRATED CIRCUITS

DESCRIPTION – The μ A4151 is a monolithic building block used to convert dc voltage to digital pulses. The frequency of the output pulses is proportional to the dc input voltage.

The μ A4151 consists of a voltage comparator, a monostable multivibrator and a precision switched current source (see block diagram).

The μ A7151 is the same device as the μ A4151 with a high performance operational amplifier on the same chip. The single supply op amp conditions the input signal and provides a significant improvement in system performance.

- SINGLE SUPPLY (+8 V_{DC} TO +30 V_{DC})
- LINEARITY TO $\pm 0.05\%$
- PROGRAMMABLE SCALE FACTOR
- PULSE OUTPUT COMPATIBLE WITH ANY LOGIC FORM
- TEMPERATURE STABILITY TYPICALLY ± 100 ppm/°C
- HIGH NOISE REJECTION
- EASILY TRANSMITTABLE OUTPUT
- SIMPLE FULL-SCALE TRIM
- SINGLE-ENDED INPUT, REFERENCED TO GROUND
- ALSO PROVIDES FREQUENCY-TO-VOLTAGE CONVERSION
- HIGH PERFORMANCE OP AMP INCLUDED IN μ A7151

ABSOLUTE MAXIMUM RATINGS

Supply Voltage	32 V
Internal Power Dissipation	670 mW
Input Voltage (Comparator)	-0.2 V to +V _{CC}
Input Voltage (Op Amp)	-0.2 V to +V _{CC}
Logic Out Shorted-to-Ground	continuous
Op Amp Out Shorted-to-Ground	continuous
Op Amp Input Common Mode Voltage Range	+13 V to -V _S
Op Amp Output Voltage Range, R _L = 10 k Ω	+2 V to +13 V
Operating Temperature Range	0°C to +70°C
Storage Temperature Range	-65°C to +150°C
Pin Temperatures	
Molded DIP (Soldering, 10 s)	260°C
Hermetic DIP (Soldering, 60 s)	300°C

CONNECTION DIAGRAMS

14-PIN DIP

(TOP VIEW)

PACKAGE OUTLINES 6A 9A
PACKAGE CODES D P

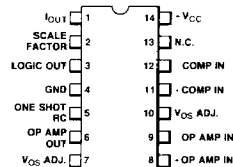

ORDER INFORMATION

TYPE	PART NO.
μ A7151	μ A7151PC

8-PIN MINI DIP

(TOP VIEW)

PACKAGE OUTLINES 9T
PACKAGE CODES T

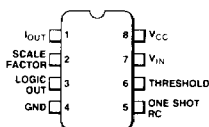

ORDER INFORMATION

TYPE	PART NO.
μ A4151	μ A4151TC

8-PIN METAL CAN

(TOP VIEW)

PACKAGE OUTLINE 5S
PACKAGE CODE H

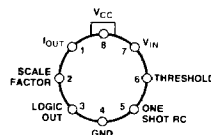

ORDER INFORMATION

TYPE	PART NO.
μ A4151	μ A4151HC

FAIRCHILD • μ A4151 • μ A7151

ELECTRICAL CHARACTERISTICS: $V_{CC} = +15\text{ V}$, $T_A = 25^\circ\text{C}$ unless otherwise specified.
 The following specs apply to the Converter Section only.

CHARACTERISTICS	CONDITIONS	MIN	TYP	MAX	UNITS
Supply Current	$8.0\text{ V} \leq V_{CC} \leq 15\text{ V}$	3.0	4.5	7.0	mA
	$15\text{ V} \leq V_{CC} \leq 22\text{ V}$	3.0	5.5	8.5	
	$22\text{ V} \leq V_{CC} \leq 30\text{ V}$	3.0	6.5	10.5	
Conversion Accuracy					
Scale Factor	Figure 2, $V_1 = 10\text{ V}$, $R_S = 14\text{ k}\Omega$	0.90	1.0	1.10	kHz/V
Drift with Temperature	Figure 2, $V_1 = 10\text{ V}$		± 100		ppm/ $^\circ\text{C}$
Drift with V_{CC}	Figure 2, $8.0\text{ V} \leq V_{CC} \leq 18\text{ V}$, $V_1 = 1.0\text{ V}$		0.2	1.0	%/V
Input Comparator					
Offset Voltage			5.0	10	mV
Offset Current			± 50	± 100	nA
Input Bias Current			-100	-300	nA
Common Mode Range (Note 1)		0	0 to $V_{CC}-2$	$V_{CC}-3.0$	V
One-Shot					
Threshold Voltage, Pin 5		0.63	0.667	0.70	$\times V_{CC}$
Input Bias Current, Pin 5			-100	-500	nA
Reset V_{sat}	Pin 5, $I = 2.2\text{ mA}$		0.15	0.50	V
Current Source					
Output Current ($V_S = 14\text{ k}\Omega$)	Pin 1, Figure 1, $V = 0$		138.7		μA
Change with Voltage	Pin 1, $V = 0\text{ V}$ to $V = 10\text{ V}$		1.0	2.5	μA
Off Leakage	Pin 1, $V = 0\text{ V}$		1.0	50	nA
Reference Voltage	Pin 2, Figure 1	1.70	1.9	2.08	V
Logic Output					
V_{sat}	Pin 3, $I = 3.0\text{ mA}$		0.15	0.50	V
V_{sat}	Pin 3, $I = 2.0\text{ mA}$		0.10	0.35	V
Off Leakage			0.1	1.0	μA

NOTE 1: Input common mode range includes ground.

μ A7151 Op-Amp

ELECTRICAL CHARACTERISTICS: $V_S = +15\text{ V}$ and ground $T_A = 25^\circ\text{C}$ unless otherwise specified.

CHARACTERISTICS	MIN	TYP	MAX	UNITS
Input Offset Voltage		2.0	5.0	mV
Input Offset Current		10	50	nA
Input Bias Current		-50	-250	nA
Input Impedance		1.0		M Ω
Common Mode Rejection Ratio	70	90		dB
Large Signal Voltage Gain, $R_L = 10\text{ k}$	50	200		V/mV
Slew Rate		0.6		V/ μs
Power Supply Rejection Ratio		15	100	$\mu\text{V/V}$
Output Short Circuit Current	10		40	mA

CIRCUIT DESCRIPTION

The μ A7151 consists of five circuit blocks as shown in Figure 1. The blocks may be connected in a variety of ways to construct voltage-to-frequency converters (VFC), frequency-to-voltage converters (FVC), or other circuit functions. The circuit blocks are:

1. A differential input comparator featuring very high gain, low offsets, and a common mode range which includes ground.
2. A one-shot multivibrator with the time constant set by an external RC ($T = 1.1RC$) connected to the RC terminal, triggered by the output of the comparator being high.
3. A precision switched current source that is turned on to the value of I_{REF} when the one-shot is on and goes to zero when the one-shot is off. The current I_{REF} is set by an external R_S , connected from the scale factor terminal-to-ground and is equal to the reference voltage divided by R_S and is optimized when set to 138 μ A.
4. An open collector output that provides a buffered output from the one-shot.
5. An operational amplifier whose common mode range includes ground and has offset null capability. The op amp has high gain, low offset voltage, low input currents, good PSRR and CMRR, and low drift.

PRINCIPLE OF OPERATION**Voltage to Frequency Conversion (VFC)**

As a voltage to frequency converter the μ A7151/4151 can be connected in several configurations depending on the input voltage, required accuracy, and response time. In all the applications we will see that the input voltage is converted to a current and the circuit will turn the switched current source on at the rate necessary so that the average current from the current source is equal to the input current. As the input voltage (and current) increases, the current source must turn on more often, and the output frequency increases.

SELECTING COMPONENTS FOR THE VFC

Voltage-to-frequency converters can be used for full scale voltages of 100 mV or greater and full scale frequencies of 1 Hz to 100 kHz. Input voltages in excess of $V_{CC} +$ can be accommodated with appropriate resistor dividers to attenuate the voltages. The following components selection guidelines should be used.

1. R_S should be approximately 14 k Ω to optimize the system performance versus temperature. R_S is normally a 12 k Ω fixed resistor and a 5 k Ω pot to be used to adjust the full scale output frequency. Small variations in R_S have minimal effect on system temperature performance.
 $I_{REF} = V_{REF}/R_S = 1.95 V/R_S$
2. $R_0 C_0$ sets the one-shot pulse width, $T_0 = 1.1 R_0 C_0$. This pulse width must be shorter than the minimum period of the maximum frequency ie, set it equal to .75 ($1/f_0$). Therefore, $R_0 C_0 = .68 (1/f_0)$. Values of R_0 should be between 6.8 k Ω and 680 k Ω and C_0 should be from .001 μ F to 1 μ F.
3. R_B should be as low as possible for the highest accuracy, (this reduces the effect of current source R_{OUT}) but must be large enough to insure that the current source output is greater than $V_{IN} \max/R_B$. Therefore, choose R_B such that $R_B \sim 1.33 V_{IN} \max/I_0$.
4. C_B for Figure 2 must be chosen to trade-off between accuracy and response time. Larger values of C_B give greater system accuracy but response time is limited by the $R_B D_B$ time constant. A good choice for D_B is $10^{-2}/f_0$.
5. C_1 for Figures 3 and 4 can be selected depending on the output frequency. The smaller C_1 is the faster the system response will be. C_1 must be large enough to limit the amplifier swing. The op amp will swing a voltage set by $I_0 T_0/C_1$, so if the comparator is biased at $2/3 V_{CC} +$ this constrains $C_1 > 3 I_0 T_0/2 V_{CC} +$. A nominal value of $C_1 = 5 \times 10^{-5}/f_0$ meets this requirement.

COMPARISON OF VOLTAGE TO FREQUENCY CIRCUITS

Table I shows a comparison of the three basic circuits set-up for a 0 to 10 V input range and a full scale output of 10 kHz.

FREQUENCY TO VOLTAGE CONVERSION

The μ A7151/4151 can be connected as frequency-to-voltage converter (FVC). This circuit basically works by putting out a current pulse per cycle of input frequency and integrating the current pulses across an output resistor to give an output voltage which is proportional to the average value of I_0 ($I_0 T_0/f_{IN}$).

TABLE I - APPLICATIONS

	Figure 2	Figure 3	Figure 4
Linearity	1.0%	0.2%	0.05%
Frequency Offset	+10 Hz	0	0
Response Time	135 μ s	200 μ s	10 μ s
Input Voltage	+	+	-
Single Supply	yes	yes	yes
Split Supply	-	-	yes

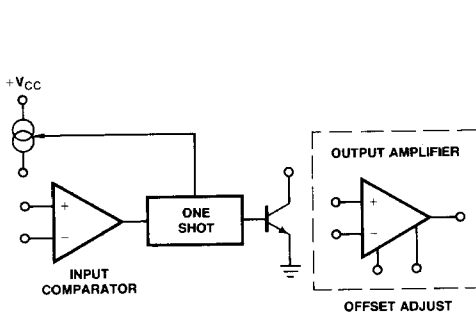
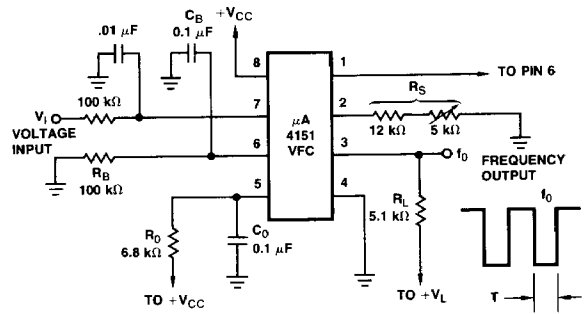

Fig. 1



DESIGN EQUATIONS

$$f_0 = KV_1 \text{ Where } K = 0.486 \frac{R_S}{R_B R_0 C_0} \frac{\text{kHz}}{\text{V}}$$

$$T = 1.1 R_0 C_0$$

Fig. 2

PRECISION VOLTAGE TO FREQUENCY CONVERTER FOR POSITIVE INPUTS

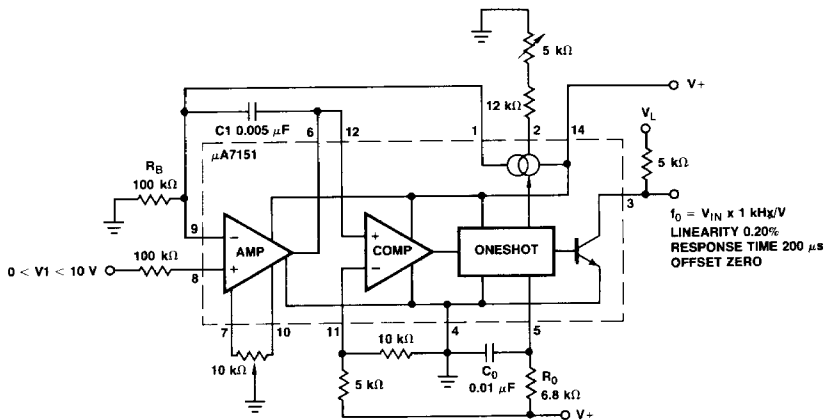

$f_0 = V_{IN} \times 1 \text{ kHz/V}$
 LINEARITY 0.20%
 RESPONSE TIME 200 μ s
 OFFSET ZERO

Fig. 3

PRECISION VOLTAGE TO FREQUENCY CONVERTER FOR NEGATIVE INPUTS

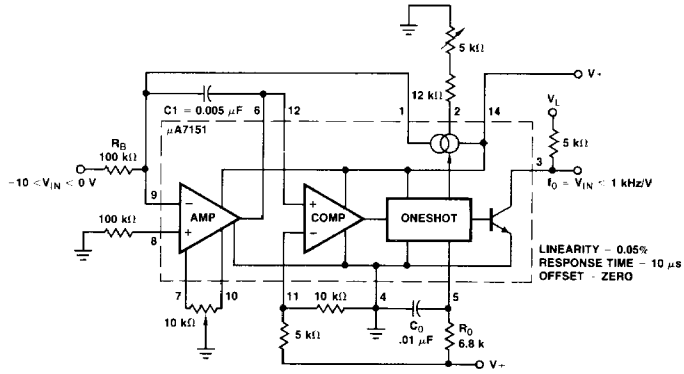
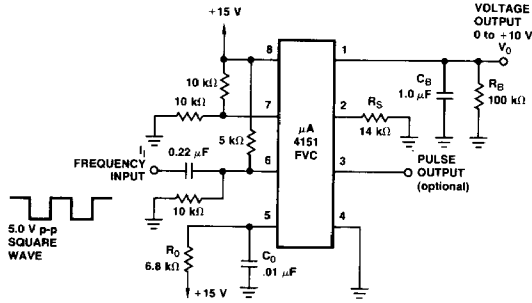

Fig. 4

SINGLE SUPPLY FREQUENCY-TO-VOLTAGE CONVERTER



DESIGN EQUATIONS

$$V_0 = I_1 K^1 \text{ Where } K = 0.486 \frac{R_S}{R_B R_0 C_0} \text{ Hz/V}$$

$$T = 1.1 R_0 C_0$$

Fig. 5

PRECISION FREQUENCY TO VOLTAGE CONVERTER

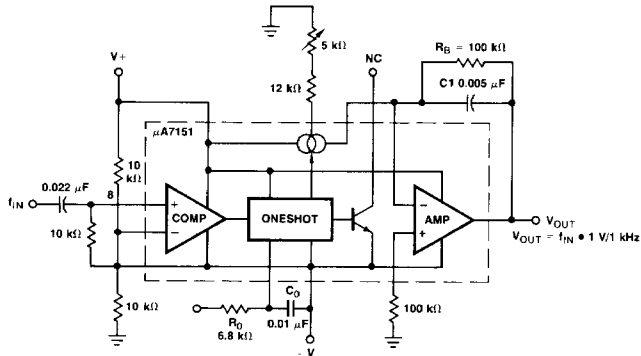

Fig. 6

LOW COST, REMOTE SENSED 8-BIT A/D CONVERTER

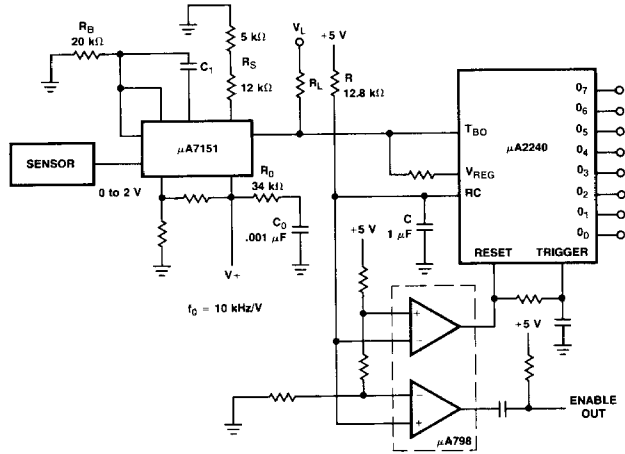

Fig. 7

MOTOR SPEED CONTROLLER

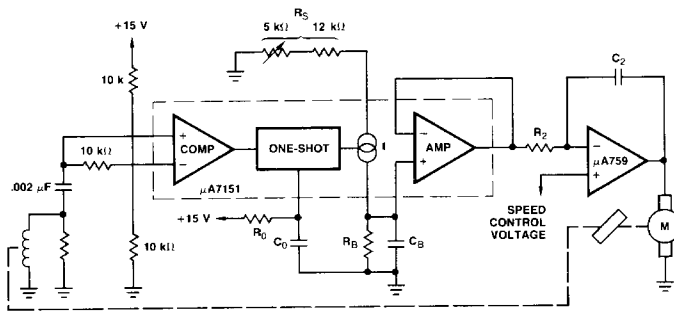

Fig. 8

FSK DEMODULATOR

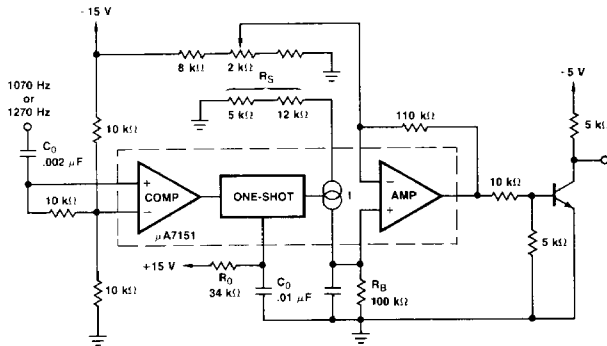

Fig. 9