



## UB211C

Preliminary

CMOS IC

### 1-CELL LITHIUM-ION/POLYMER BATTERY PROTECTION IC

#### DESCRIPTION

UTC **UB211C** is a series of lithium-ion / lithium-polymer rechargeable battery protection ICs incorporating high accuracy voltage detection circuits and delay circuits.

UTC **UB211C** is suitable for protection of single cell lithium-ion / lithium polymer battery packs from overcharge, over discharge and over current.

The ultra-small package and less requirement of external components make it ideal to integrate the UTC **UB211C** into the limited space of battery pack.

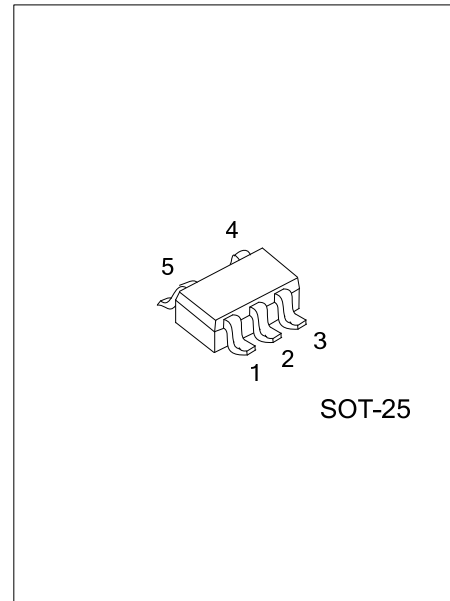

#### FEATURES

- \* Wide Supply Voltage Range:  $V_{DD}=1.5V\sim 8.0V$
- \* Ultra-Low Quiescent Current:  $I_{OPE}=3.0\mu A$  ( $V_{DD}=3.5V$ )
- \* Ultra-Low Power-Down Current:  $I_{PDN}=0.2\mu A$  ( $V_{DD}=1.5V$ )
- \* Overcharge Detection Voltage:  $V_{CU}=3.9V\sim 4.4V$
- \* Overcharge Release Voltage:  $V_{CL}=3.8V\sim 4.4V$
- \* Over Discharge Release Voltage:  $V_{DL}=2.0V\sim 3.0V$
- \* Over Discharge Release Voltage:  $V_{DU}=2.0V\sim 3.4V$
- \* Discharge Over Current Detection Voltage:  $V_{DOIV}=0.05V\sim 0.30V$
- \* Discharge Short Circuit Detection Voltage:  $V_{SHORT}=0.5V$  (Fixed)
- \* Charge Over Current Voltage:  $V_{COIV}=-0.1V$  (Fixed)
- \* Charger Detection Voltage:  $V_{CHA}=-0.7V$  (Fixed)
- \* Delay Times are Generated by an Internal Circuit. (External Capacitors are Unnecessary.)

#### ORDERING INFORMATION

Ordering Number		Package	Packing
Lead Free	Halogen Free		
UB211CL-xx-AF5-R	UB211CG-xx-AF5-R	SOT-25	Tape Reel

Note: xx: Output Voltage, refer to Marking Information.

UB211CG-xx-AF5-R	(1)Packing Type	(1) R: Tape Reel
	(2)Package Type	(2) AF5: SOT-25
	(3)Output Voltage Code	(3) xx: Refer to Marking Information
	(4)Green Package	(4) G: Halogen Free and Lead Free, L: Lead Free

### MARKING INFORMATION

PACKAGE	VOLTAGE CODE (Note)	MARKING
SOT-25	AA	<p>L: Lead Free G: Halogen Free Voltage Code</p>
	AB	

Note: Refer to Serial Code List

### SERIAL CODE LIST

Model	Code	Overcharge Detection Voltage [V <sub>CU</sub> ](V)	Overcharge Release Voltage [V <sub>CL</sub> ](V)	Over discharge Detection Voltage [V <sub>DL</sub> ](V)	Over discharge Release Voltage [V <sub>DU</sub> ](V)	Over Current Detection Voltage [V <sub>DIOV</sub> ](V)
UB211C	AA	4.200	4.100	2.800	2.900	0.150
UB211C	AB	4.280	4.130	2.800	3.100	0.150

### PIN CONFIGURATION

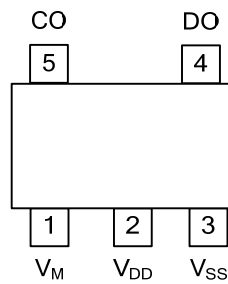

### PIN DESCRIPTION

PIN NO.	PIN NAME	DESCRIPTION
1	V <sub>M</sub>	For current sense and charger detection input pin
2	V <sub>DD</sub>	Positive power input
3	V <sub>SS</sub>	Negative power input
4	DO	For discharge control: FET gate connection pin
5	CO	For charge control: FET gate connection pin

■ BLOCK DIAGRAM

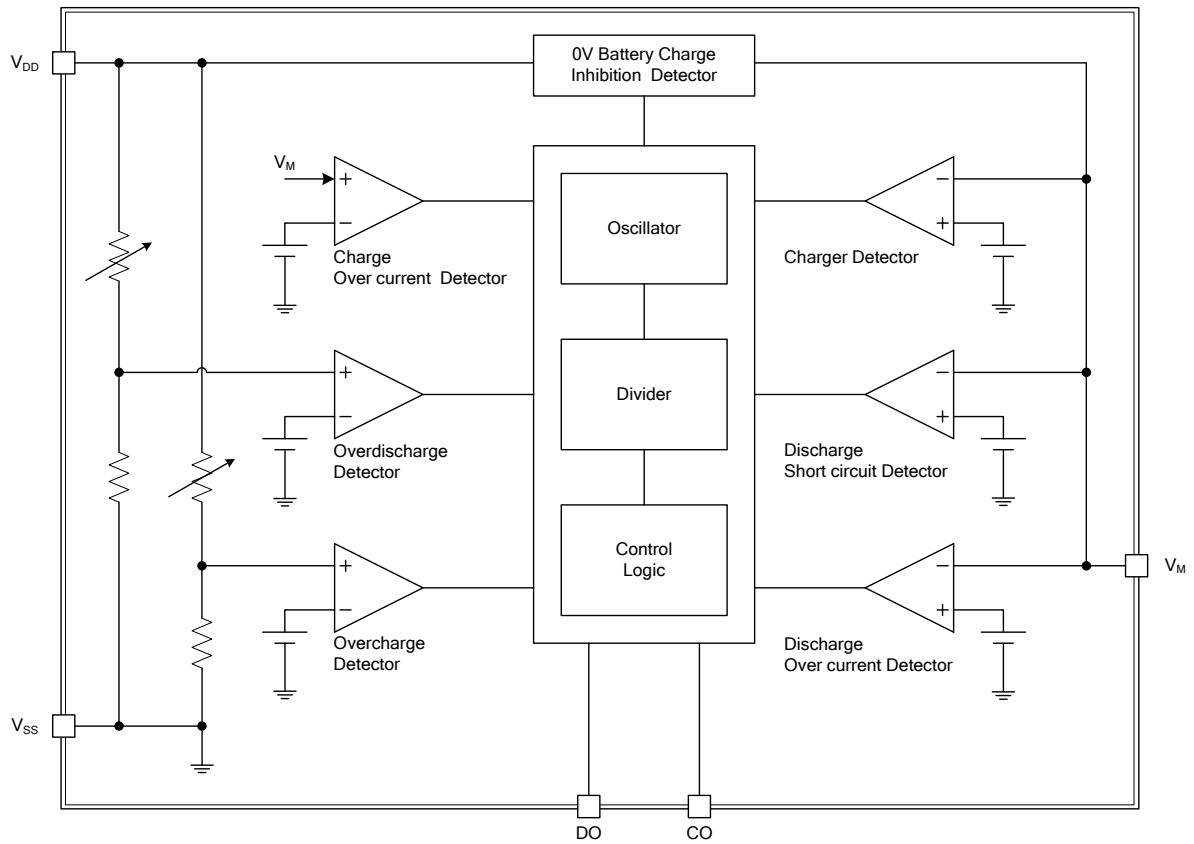

■ ABSOLUTE MAXIMUM RATING ( $V_{SS}=0V$ ,  $T_A=25^\circ C$  unless otherwise specified)

PARAMETER	SYMBOL	RATINGS	UNIT
Input Voltage Between $V_{DD}$ and $V_{SS}$ (Note2)	$V_{DD}$	$V_{SS}-0.3 \sim V_{SS}+12$	V
CO Output Pin Voltage	$V_{CO}$	$V_{DD}-12 \sim V_{DD}+0.3$	V
DO Output Pin Voltage	$V_{DO}$	$V_{SS}-0.3 \sim V_{DD}+0.3$	V
VM Input Pin Voltage	$V_M$	$V_{DD}-14 \sim V_{DD}+0.3$	V
Ambient Operating Temperature	$T_{OPR}$	-40 ~ +85	$^\circ C$
Storage Temperature	$T_{STG}$	-55 ~ +125	$^\circ C$

Note: 1. Absolute maximum ratings are those values beyond which the device could be permanently damaged.

Absolute maximum ratings are stress ratings only and functional device operation is not implied.

2. Pulse ( $\mu sec$ ) noise exceeding the above input voltage ( $V_{SS}+12V$ ) may cause damage to the IC.

■ ELECTRICAL CHARACTERISTICS ( $V_{SS}=0V$ ,  $T_a=25^\circ C$  unless otherwise specified)

PARAMETER	SYMBOL	TEST CONDITIONS	MIN	TYP	MAX	UNIT
<b>CURRENT CONSEPTION</b>						
Supply Current	$I_{OPE}$	$V_{DD}=3.5V$ , $V_M=0V$		3.0	8.0	$\mu A$
Power-Down Current	$I_{PDN}$	$V_{DD}=V_M=1.5V$		0.2	0.5	$\mu A$
<b>OPERATING VOLTAGE</b>						
Operating Voltage Between $V_{DD}$ -pin and $V_{SS}$ -pin	$V_{DS1}$		1.5		8	V
Operating Voltage Between $V_{DD}$ -pin and $V_M$ -pin	$V_{DS2}$		1.5		10	V
<b>DETECTION VOLTAGE</b>						
Overcharge Detection Voltage	$V_{CU}$		$V_{CU}-0.040$	$V_{CU}$	$V_{CU}+0.040$	V
Overcharge Release Voltage	$V_{CL}$	$V_{CL} \neq V_{CU}$	$V_{CL}-0.050$	$V_{CL}$	$V_{CL}+0.050$	V
		$V_{CL}=V_{CU}$	$V_{CL}-0.040$	$V_{CL}$	$V_{CL}+0.040$	V
Overdischarge Detection Voltage	$V_{DL}$		$V_{DL}-0.080$	$V_{DL}$	$V_{DL}+0.080$	V
Overdischarge Release Voltage	$V_{DU}$	$V_{DU} \neq V_{DL}$	$V_{DU}-0.100$	$V_{DU}$	$V_{DU}+0.100$	V
		$V_{DU}=V_{DL}$	$V_{DU}-0.080$	$V_{DU}$	$V_{DU}+0.080$	V
Discharge Over Current Detection Voltage	$V_{DIOV}$	$V_{DD}=3.0V$	$V_{DIOV}-0.03$	$V_{DIOV}$	$V_{DIOV}+0.03$	V
Discharge Short Circuit Detection Voltage	$V_{SHORT}$	$V_{DD}=3.0V$	0..30	0.50	0.70	V
Charge Over Current Detection Voltage	$V_{CIOV}$		-0.18	-0.10	-0.02	V
Charger Detection Voltage	$V_{CHA}$	$V_{DU} \neq V_{DL}$	-1.2	-0.7	-0.2	V
<b>0V BATTERY CHARGE VOLTAGE</b>						
0V Battery Charge Inhibition Battery Voltage	$V_{0INH}$				1.8	V
<b>INTERNAL RESISTANCE</b>						
Resistance between VM-pin and $V_{SS}$ -pin	$R_{VMD}$	$V_{DD}=1.8V$ , $V_M=0V$	100	300	900	k $\Omega$
Resistance between VM-pin and $V_{DD}$ -pin	$R_{VMD}$	$V_{DD}=3.5V$ , $V_M=1.0V$	10	30	70	k $\Omega$
<b>OUTPUT RESISTANCE</b>						
CO-pin Resistance "H"	$R_{COH}$	$V_{CO}=3.0V$ , $V_{DD}=3.5V$ , $V_M=0V$		5	10	k $\Omega$
CO-pin Resistance "L"	$R_{COL}$	$V_{CO}=0.5V$ , $V_{DD}=4.5V$ , $V_M=0V$		5	10	k $\Omega$
DO-pin Resistance "H"	$R_{DOH}$	$V_{DO}=3.0V$ , $V_{DD}=3.5V$ , $V_M=0V$		5	10	k $\Omega$
DO-pin Resistance "L"	$R_{DOL}$	$V_{DO}=0.5V$ , $V_{DD}=V_M=1.8V$		5	10	k $\Omega$
<b>DELAY TIME</b>						
Overcharge Detection Delay Time	$t_{CU}$		0.9	1.2	1.5	s
Overdischarge Detection Delay Time	$t_{DL}$		110	150	190	ms
Discharge Over Current Detection Delay Time	$t_{DIOV}$	$V_{DD}=3.0V$	6	9	12	ms
Discharge Short Circuit Detection Delay Time	$t_{SHORT}$	$V_{DD}=3.0V$	120	300	380	$\mu s$
Charge Over Current Detection Delay Time	$t_{CIOV}$		6	9	12	ms

## ■ OPERATION

### 1. Normal Condition

This IC monitors the voltage of the battery connected between the  $V_{DD}$  pin and  $V_{SS}$  pin and the voltage difference between the VM pin and  $V_{SS}$  pin to control charging and discharging. When the battery voltage is in the range from overdischarge detection voltage ( $V_{DL}$ ) to overcharge detection voltage ( $V_{CU}$ ), and the VM pin voltage is in the range from the charge overcurrent detection voltage ( $V_{CIOV}$ ) to discharge overcurrent detection voltage ( $V_{DIOV}$ ), the IC turns both the charging and discharging control FETs on. This condition is called the normal condition, and in this condition charging and discharging can be carried out freely.

The resistance ( $R_{VMD}$ ) between the VM pin and  $V_{DD}$  pin, and the resistance ( $R_{VMS}$ ) between the VM pin and  $V_{SS}$  pin are not connected in the normal status.

Note: When the battery is connected for the first time, discharging may not be enabled. In this case, short the VM pin and  $V_{SS}$  pin or connect the charger to restore the normal condition.

### 2. Overcharge Condition

When the battery voltage becomes higher than overcharge detection voltage ( $V_{CU}$ ) during charging in the normal condition and this state continues for the overcharge detection delay time ( $t_{CU}$ ), the UTC **UB211C** Series turns the charging control FET off to stop charging. This state is called the overcharge condition.

The resistance ( $R_{VMD}$ ) between the  $V_M$  pin and  $V_{DD}$  pin, and the resistance ( $R_{VMS}$ ) between the  $V_M$  pin and  $V_{SS}$  pin are not connected in the overcharge condition. The overcharge condition is released in the following two cases.

(1) When the VM pin voltage is higher than or equal to the charge overcurrent detection voltage ( $V_{CIOV}$ ), and is lower than the discharge overcurrent detection voltage ( $V_{DIOV}$ ), UTC **UB211C** Series releases the overcharge status when the battery voltage falls below the overcharge release voltage ( $V_{CL}$ ).

(2) When the VM pin voltage is higher than or equal to the discharge overcurrent detection voltage ( $V_{DIOV}$ ), UTC **UB211C** Series releases the overcharge condition when the battery voltage falls below the overcharge detection voltage ( $V_{CU}$ ).

The discharge is started by connecting a load after the overcharge detection, the VM pin voltage rises more than the voltage at  $V_{SS}$  pin, because the discharge current flows through the charging control FET. If this VM pin voltage is higher than or equal to the discharge overcurrent detection voltage ( $V_{DIOV}$ ), UTC **UB211C** Series releases the overcharge status when the battery voltage is lower than or equal to the overcharge detection voltage ( $V_{CU}$ ).

For the actual application boards, changing the battery voltage and the charger voltage simultaneously enables to measure the overcharge release voltage ( $V_{CL}$ ). In this case, the charger is always necessary to have the equivalent voltage level to the battery voltage. The charger keeps VM pin voltage higher than or equal to the charge overcurrent detection voltage ( $V_{CIOV}$ ) and lower than or equal to the discharge overcurrent detection voltage ( $V_{DIOV}$ ). UTC **UB211C** Series releases the overcharge status when the battery voltage falls below the overcharge release voltage ( $V_{CL}$ ).

Note 1. If the battery is charged to a voltage higher than overcharge detection voltage ( $V_{CU}$ ) and the battery voltage does not fall below overcharge detection voltage ( $V_{CU}$ ) even when a heavy load is connected, discharge overcurrent detection and load short-circuiting detection do not function until the battery voltage falls below overcharge detection voltage ( $V_{CU}$ ). Since an actual battery has an internal impedance of tens of m $\Omega$ , the battery voltage drops immediately after a heavy load that causes overcurrent is connected, and discharge overcurrent detection and load shortcircuiting detection function.

Note 2. When a charger is connected after overcharge detection, the overcharge status is not released even if the battery voltage is below overcharge release voltage ( $V_{CL}$ ). The overcharge status is released when the VM pin voltage goes over the charge overcurrent detection voltage ( $V_{CIOV}$ ) by removing the charger.

### 3. Overdischarge Condition

When the battery voltage falls below overdischarge detection voltage ( $V_{DL}$ ) during discharging in the normal status and the detection continues for the overdischarge detection delay time ( $t_{DL}$ ) or longer, the UTC **UB211C** Series turns the discharging control FET off to stop discharging. This condition is called the overdischarge status. Under the overdischarge status, the  $V_M$  pin voltage is pulled up by the resistor between the VM pin and  $V_{DD}$  pin in the IC ( $R_{VMD}$ ). When voltage difference between the  $V_M$  pin and  $V_{DD}$  pin then is 1.3 V (Typ.) or lower, the current consumption is reduced to the power-down current consumption ( $I_{PDN}$ ). This condition is called the power-down status. The resistance ( $R_{VMS}$ ) between the  $V_M$  pin and  $V_{SS}$  pin is not connected in the power-down status and the overdischarge status.

The power-down status is released when a charger is connected and the voltage difference between the  $V_M$  pin and  $V_{DD}$  pin becomes 1.3 V (typ.) or higher.

When a battery in the overdischarge condition is connected to a charger and provided that the  $V_M$  pin voltage is lower than -0.7 V (Typ.), the UTC **UB211C** Series releases the overdischarge status and turns the discharging FET on when the battery voltage reaches overdischarge detection voltage ( $V_{DL}$ ) or higher.

When a battery in the overdischarge status is connected to a charger and provided that the  $V_M$  pin voltage is not lower than -0.7 V (Typ.), the UTC **UB211C** Series releases the overdischarge status when the battery voltage reaches overdischarge release voltage ( $V_{DU}$ ) or higher.

## ■ OPERATION (Cont.)

### 4. Discharge Overcurrent Condition (Discharge Overcurrent, Load Short-circuiting)

When a battery in the normal condition is in the status where the voltage of the  $V_M$  pin is equal to or higher than the discharge overcurrent detection voltage because the discharge current is higher than the specified value and the status lasts for the discharge overcurrent detection delay time, the discharge control FET is turned off and discharging is stopped. This status is called the discharge overcurrent condition.

In the discharge overcurrent condition, the  $V_M$  pin and  $V_{SS}$  pin are shorted by the resistor between  $V_M$  pin and  $V_{SS}$  pin ( $R_{VMS}$ ) in the IC. However, the voltage of the  $V_M$  pin is at the  $V_{DD}$  potential due to the load as long as the load is connected. When the load is disconnected, the  $V_M$  pin returns to the  $V_{SS}$  potential.

This IC detects the condition when the impedance between the EB+ pin and EB- pin (Refer to the **typical application circuit**) increases and is equal to the impedance that enables automatic restoration and the voltage at the VM pin returns to discharge overcurrent detection voltage ( $V_{DIOV}$ ) or lower, the discharge overcurrent condition is restored to the normal condition.

Even if the connected impedance is smaller than automatic restoration level, the UTC **UB211C** Series will be restored to the normal status from discharge overcurrent detection status when the voltage at the  $V_M$  pin becomes the discharge overcurrent detection voltage ( $V_{DIOV}$ ) or lower by connecting the charger.

The resistance ( $R_{VMD}$ ) between the  $V_M$  pin and  $V_{DD}$  pin is not connected in the discharge overcurrent detection condition.

### 5. Charge Overcurrent Condition

When a battery in the normal status is in the status where the voltage of the  $V_M$  pin is lower than the charge overcurrent detection voltage because the charge current is higher than the specified value and the status lasts for the charge overcurrent detection delay time, the charge control FET is turned off and charging is stopped. This status is called the charge overcurrent status.

This IC will be restored to the normal status from the charge overcurrent status when, the voltage at the VM pin returns to charge overcurrent detection voltage ( $V_{CIOV}$ ) or higher by removing the charger.

The charge overcurrent detection function does not work in the overdischarge status.

The resistance ( $R_{VMD}$ ) between the VM pin and VDD pin, and the resistance ( $R_{VMS}$ ) between the VM pin and VSS pin are not connected in the charge overcurrent status.

### 6. 0 V Battery Charging Function “Unavailable”

This function inhibits recharging when a battery that is internally short-circuited (0 V battery) is connected. When the battery voltage is the 0 V battery charge inhibition battery voltage ( $V_{0INH}$ ) or lower, the charging control FET gate is fixed to the EB- pin (Refer to the **typical application circuit**) voltage to inhibit charging. When the battery voltage is the 0 V battery charge inhibition battery voltage ( $V_{0INH}$ ) or higher, charging can be performed.

Caution Some battery providers do not recommend charging for a completely self-discharged battery. Please ask the battery provider to determine whether to enable or inhibit the 0 V battery charging function.

### 7. Delay Circuit

(1) The discharge overcurrent detection delay time ( $t_{DIOV}$ ) and the load short-circuiting detection delay time ( $t_{SHORT}$ ) start when the discharge overcurrent detection voltage ( $V_{DIOV}$ ) is detected. When the load short-circuiting detection voltage ( $V_{SHORT}$ ) is detected over the load short-circuiting detection delay time ( $t_{SHORT}$ ) after the detection of discharge overcurrent detection voltage ( $V_{DIOV}$ ), the UTC **UB211C** turns the discharging control FET off within  $t_{SHORT}$  from the time of detecting  $V_{SHORT}$ .

(2) When any overcurrent is detected and the overcurrent continues for longer than the overdischarge detection delay time ( $t_{DL}$ ) without the load being released, the status changes to the power-down status at the point where the battery voltage falls below overdischarge detection voltage ( $V_{DL}$ ).

(3) When the battery voltage falls below overdischarge detection voltage ( $V_{DL}$ ) due to overcurrent, the UTC **UB211C** Series turns the discharging control FET off via overcurrent detection. In this case, if the recovery of the battery voltage is so slow that the battery voltage after the overdischarge detection delay time is still lower than the overdischarge detection voltage, UTC **UB211C** Series shifts to the power-down status.

■ TIMING CHART

(1) Overcharge Detection, Overdischarge Detection

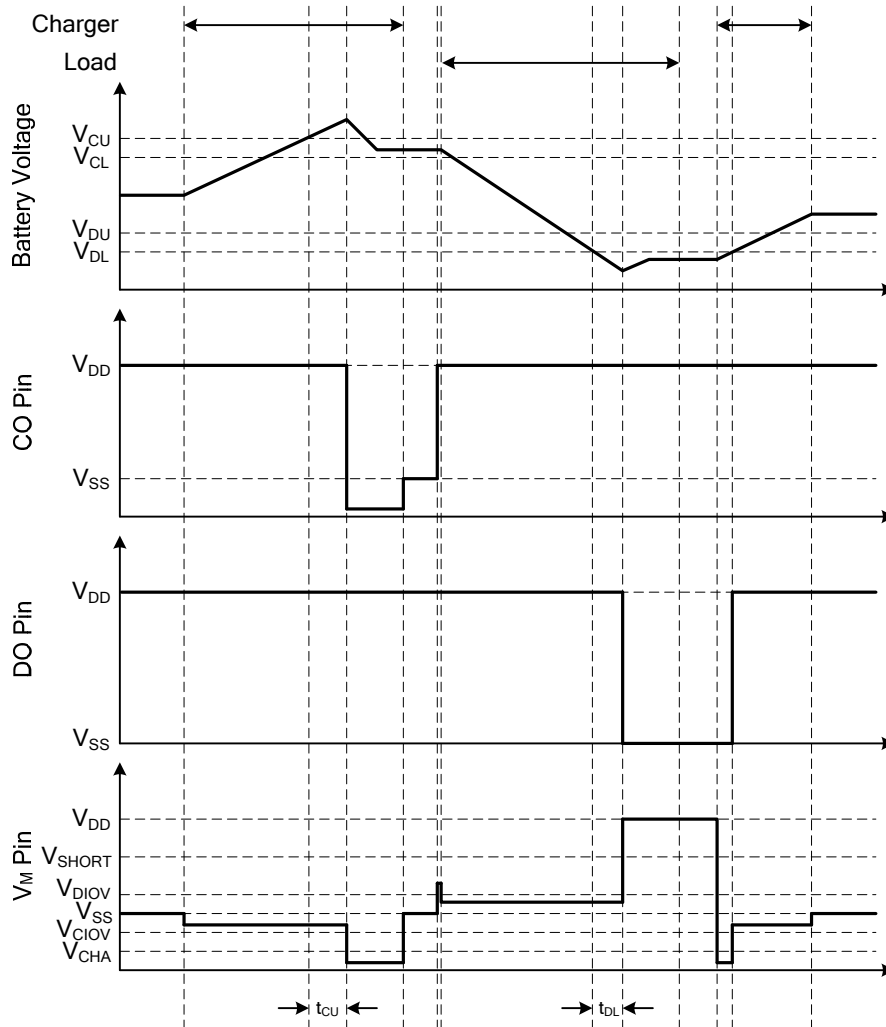

■ TIMING CHART (Cont.)

(2) Discharge Overcurrent Detection

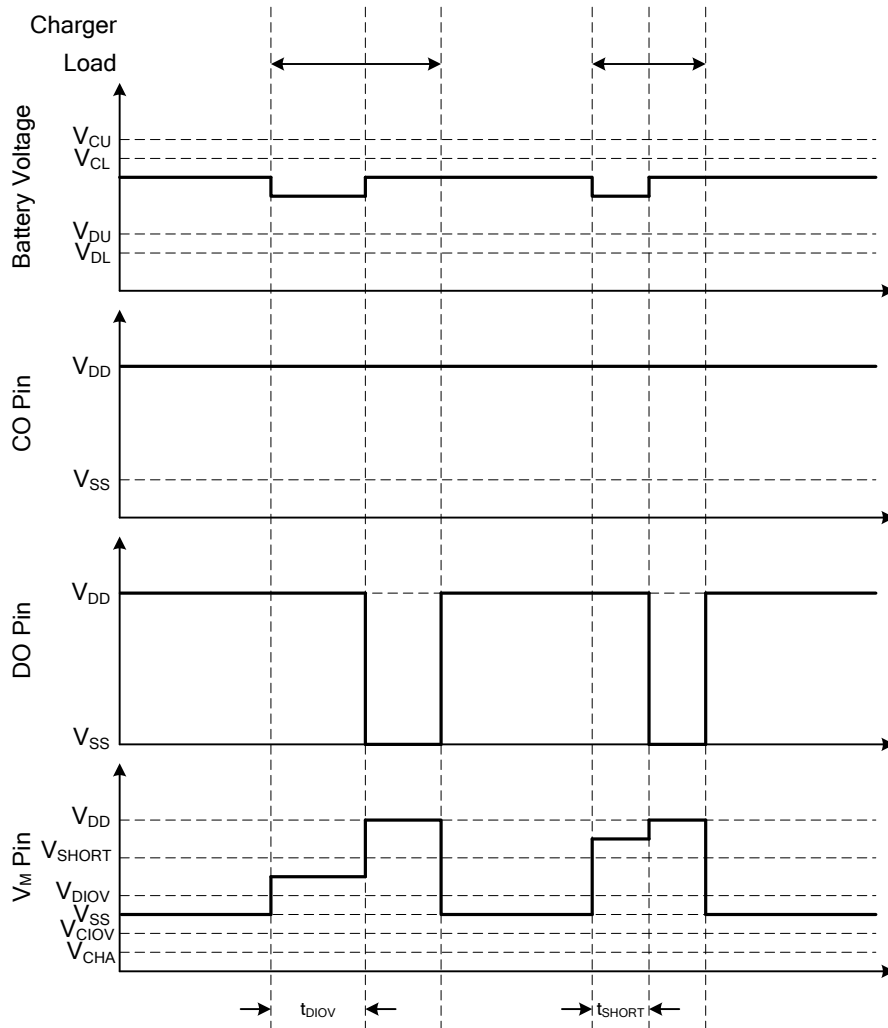



■ TIMING CHART (Cont.)

(3) Charge Overcurrent Detection

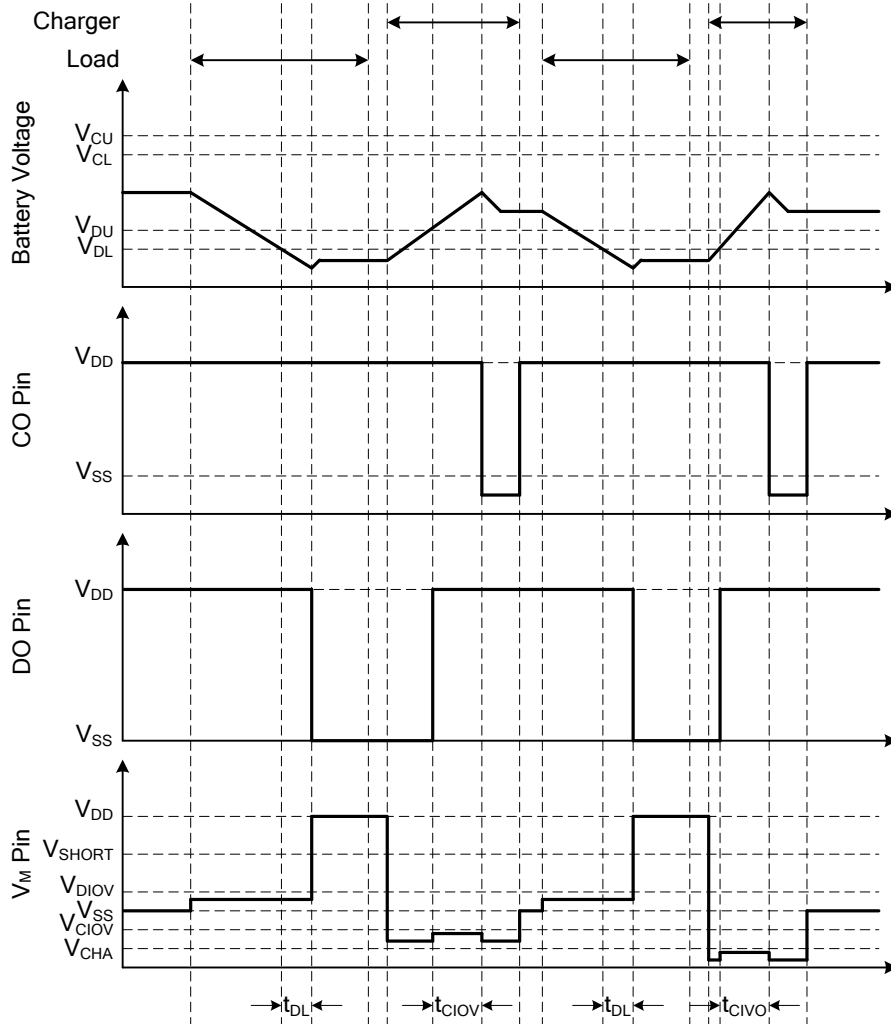

■ TYPICAL APPLICATION CIRCUIT

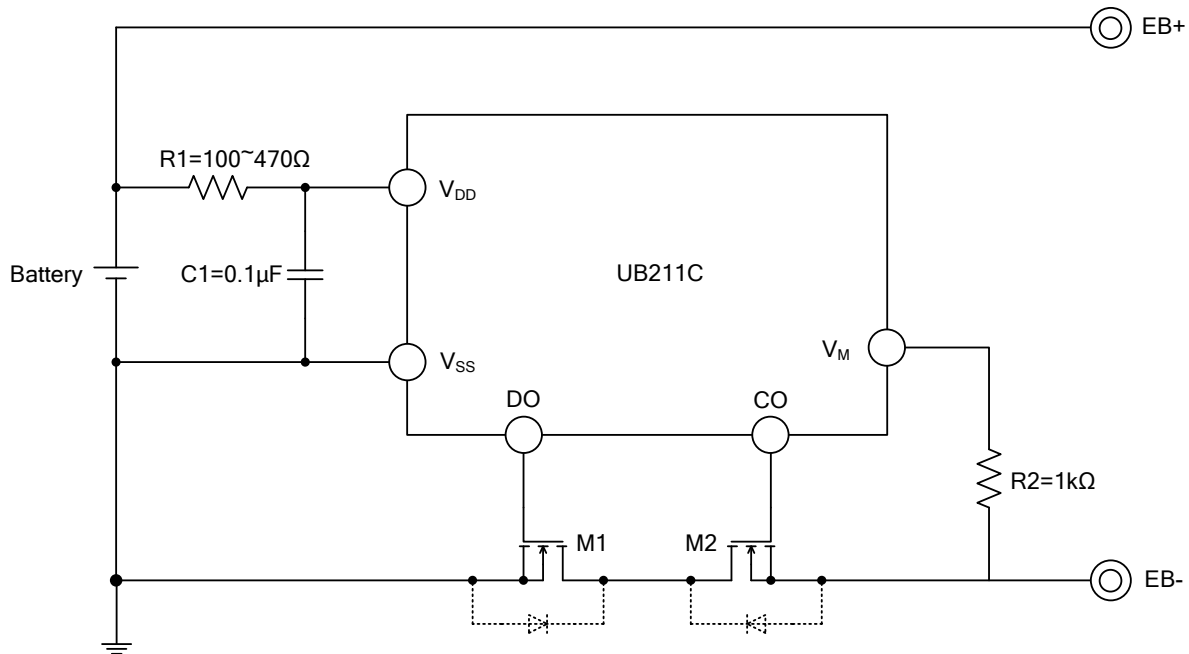

- Note 1. Overdischarge detection voltage must be higher than the threshold voltage of M1 and M2, if not, the M1 may not cut the charging current. If the threshold voltage of M1 equal to or higher than the overdischarge detection voltage is used, discharging may be stopped before overdischarge is detected.
2. Charger voltage must be higher than the withstanding voltage between the gate and source of M1 and M2, if not, M1 and M2 may be destroyed.
3. Resistance of R1 can't be high, the value is about from 100Ω to 470Ω, If R1 has a high resistance, the voltage between VDD pin and VSS pin may exceed the absolute maximum rating when a charger is connected in reverse since the current flows from the charger to the IC. Insert a resistor of 100Ω or higher as R1 for ESD protection
4. the capacitance of C1 must not be less than 0.022μF, if not, DO pin may oscillate when load short-circuiting is detected. Be sure to connect a capacitor of 0.022μF or higher to C1, the typical value is about 0.1μF.
5. the resistance of R2 can not be higher than 2kΩ, if not, the charging current may not be cut when a high-voltage charger is connected.

UTC assumes no responsibility for equipment failures that result from using products at values that exceed, even momentarily, rated values (such as maximum ratings, operating condition ranges, or other parameters) listed in products specifications of any and all UTC products described or contained herein. UTC products are not designed for use in life support appliances, devices or systems where malfunction of these products can be reasonably expected to result in personal injury. Reproduction in whole or in part is prohibited without the prior written consent of the copyright owner. The information presented in this document does not form part of any quotation or contract, is believed to be accurate and reliable and may be changed without notice.