

# DATA SHEET

## **UBA1710M**

**Modulator for GaAs power  
amplifiers**

Product specification  
Supersedes data of 1997 Feb 18  
File under Integrated Circuits, IC17

1997 Oct 17

**Modulator for GaAs power amplifiers****UBA1710M****FEATURES**

- Power MOS modulators for control of GaAs power amplifier drain voltage
- Power control loop amplifier and MOS driver
- Voltage tripler for supply of MOS driver
- Positive-to-negative DC converter for GaAs power amplifier gate biasing.

**APPLICATIONS**

- Control of GaAs power amplifiers for GSM and DCS hand-held transceivers.

**GENERAL DESCRIPTION**

The UBA1710M integrates the functions required to operate the GaAs Power Amplifiers (PAs) from the CGY20xx family which are intended for GSM and DCS applications.

It includes a negative supply for PA gate biasing and most of the functions required to implement power control so that only a very few external component are required. The power control section integrates two power MOS devices for control of the PA drain voltages, an MOS driver and a feedback loop amplifier. The MOS driver is supplied from an on-chip voltage tripler.

**QUICK REFERENCE DATA**

SYMBOL	PARAMETER <sup>(1)</sup>	MIN.	TYP.	MAX.	UNIT
V <sub>CC</sub>	analog supply voltage	4.2	4.8	7.5	V
V <sub>DD</sub>	digital supply voltage	4.2	4.8	7.5	V
I <sub>CC</sub> + I <sub>DD</sub>	peak supply current in power-up mode	–	12	–	mA
T <sub>amb</sub>	operating ambient temperature	–20	–	+85	°C

**Note**

1. For conditions, see Chapter "Characteristics".

**ORDERING INFORMATION**

TYPE NUMBER	PACKAGE		
	NAME	DESCRIPTION	VERSION
UBA1710M	SSOP20	plastic shrink small outline package; 20 leads; body width 4.4 mm	SOT266-1

Modulator for GaAs power amplifiers

UBA1710M

BLOCK DIAGRAM

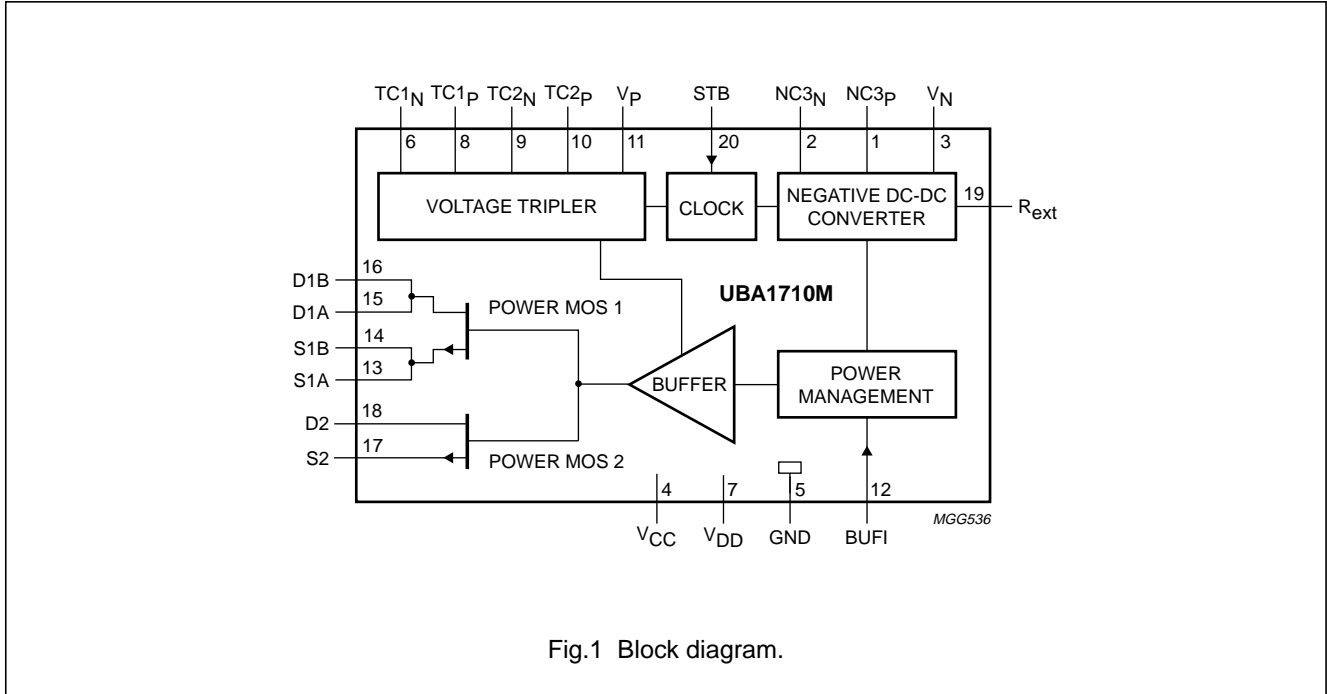

Fig.1 Block diagram.

PINNING

SYMBOL	PIN	DESCRIPTION
NC3P	1	charge pump tank capacitor
NC3N	2	charge pump tank capacitor
V <sub>N</sub>	3	negative bias voltage
V <sub>CC</sub>	4	analog supply voltage
GND	5	ground
TC1 <sub>N</sub>	6	charge pump tank capacitor
V <sub>DD</sub>	7	digital supply voltage
TC1 <sub>P</sub>	8	charge pump tank capacitor
TC2 <sub>N</sub>	9	charge pump tank capacitor
V <sub>P</sub>	11	positive tripler voltage
BUFI	12	buffer input
S1A	13	power MOS 1 source A
S1B	14	power MOS 1 source B
D1A	15	power MOS 1 drain A
D1B	16	power MOS 1 drain B
S2	17	power MOS 2 source
D2	18	power MOS 2 drain
R <sub>ext</sub>	19	external resistance for V <sub>N</sub>
STB	20	standby input (active HIGH)

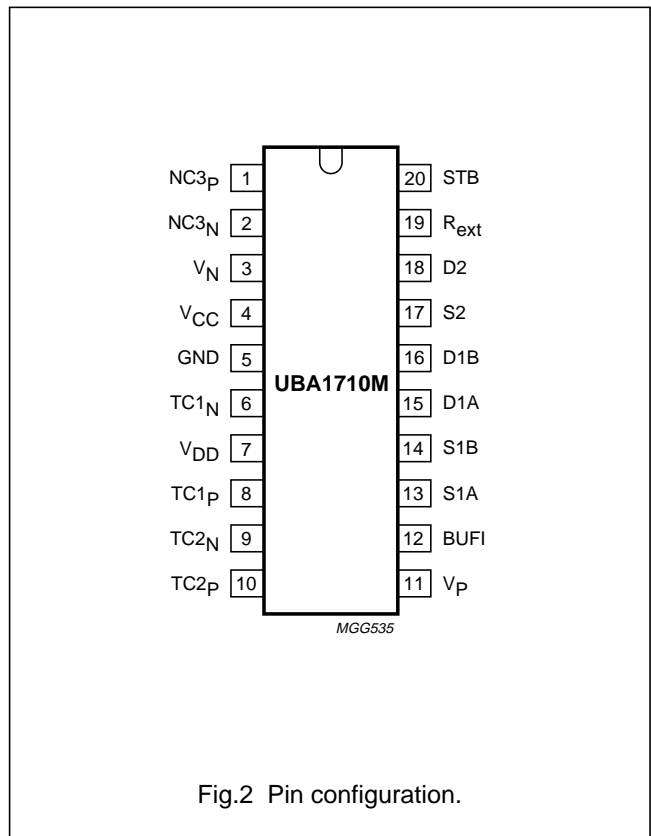

Fig.2 Pin configuration.

## Modulator for GaAs power amplifiers

## UBA1710M

**FUNCTIONAL DESCRIPTION****Power control section**

Power control for GaAs PAs from the CGY20xx family is achieved by varying the drain voltage. This is achieved with the UBA1710M by means of the two power MOS devices integrated on-chip. They enable separate control of the PA output stage from the pre-amplifier stages. They have a very low 'on' resistance for low drop voltage at high RF output power.

The MOS devices are driven by a buffer. The buffer amplifier, in association with power MOS, is included in a feedback loop to exhibit a high cut-off frequency (3 MHz) over the whole control dynamic range. This buffer allows fast switching of the MOS in accordance with GSM power ramping requirements.

**DC-DC converters**

One DC-DC converter is required to provide negative gate biasing to the GaAs PA.

The standard value is typically  $-2$  V, without any external resistor connected. The other one is a voltage tripler and is required to supply the MOS driver. The driver is required to raise the MOS gate voltage well above the battery voltage in order to open the MOS switches ('high side' driver).

These DC-DC converters are operated at a typical frequency of 600 kHz supplied by an internal oscillator. Five external capacitors with a typical value of  $0.1 \mu\text{F}$  (0603 SMD) are required to operate these converters.

**Power management**

The power management disables the PA drain voltage and prevents the PA from burnout if drain voltage is supplied before the negative gate voltage is available.

**Standby mode**

An additional feature includes a standby mode, reducing the current consumption to a maximum value of  $1 \mu\text{A}$ .

**LIMITING VALUES**

In accordance with the Absolute Maximum Rating System (IEC 134); general operating conditions applied.

SYMBOL	PARAMETER	MIN.	MAX.	UNIT
$V_{CC}$	analog supply voltage	-0.5	+9.0	V
$V_{DD}$	digital supply voltage	-0.5	+9.0	V
$V_I$	DC input voltage			
	all pins (except BUFI)	-0.5	+9.0	V
	pin BUFI	-0.5	+5.0	V
$I_I$	DC current into any signal pin	-10	+10	mA
$P_{tot}$	total power dissipation	-	0.65	W
$T_{stg}$	storage temperature	-65	+150	°C
$T_{amb}$	operating ambient temperature	-20	+85	°C

**THERMAL CHARACTERISTICS**

SYMBOL	PARAMETER	VALUE	UNIT
$R_{th\ j-a}$	thermal resistance from junction to ambient	100	K/W

## Modulator for GaAs power amplifiers

UBA1710M

**CHARACTERISTICS** $V_{CC} = V_{DD} = 4.8 \text{ V}$ ;  $T_{amb} = 25 \text{ }^\circ\text{C}$ ; unless otherwise specified.

SYMBOL	PARAMETER	CONDITIONS	MIN.	TYP.	MAX.	UNIT
<b>Supplies</b>						
$I_{CC} + I_{DD}$	peak supply current	power-up mode; PA on	–	12	–	mA
		power-down mode; PA off	–	5	–	mA
$I_{stb}$	standby current	standby mode	–	0.1	1	$\mu\text{A}$
<b>Power MOS 1</b>						
$R_{DSon1}$	on resistance	$I_{DS} = 1.3 \text{ A}$	–	0.18	–	$\Omega$
<b>Power MOS 2</b>						
$R_{DSon2}$	on resistance	$I_{DS} = 0.4 \text{ A}$	–	0.5	–	$\Omega$
<b>Clock circuit</b>						
$f_{clk}$	clock frequency		–	600	–	kHz
<b>Voltage tripler</b>						
$V_{Po}$	output voltage	with $I_{Po} = 2 \text{ mA}$	11.3	11.8	12.3	V
$V_{R(p-p)}$	amplitude ripple (peak-to-peak value)	with $I_{Po} = 2 \text{ mA}$ ; $C1 = C2 = 100 \text{ nF}$ ; $C_P = 100 \text{ nF}$	–	20	–	mV
$t_{on}$	turn-on time		–	100	–	$\mu\text{s}$
<b>Negative DC/DC converter</b>						
$V_{No}$	output voltage	with $I_{No} = 250 \text{ } \mu\text{A}$ ; $R_{ext} = 470 \text{ k}\Omega$	–1.5	–1.8	–2.0	V
$V_{R(p-p)}$	amplitude ripple (peak-to-peak value)	with $I_{No} = 250 \text{ } \mu\text{A}$ ; $C3 = 100 \text{ nF}$ ; $C_N = 100 \text{ nF}$	–	2	–	mV
$t_{on}$	turn-on time		–	280	–	$\mu\text{s}$
<b>MOS buffer amplifier</b>						
$V_{IL}$	LOW level input voltage		–	1.2	–	V
$V_{IH}$	HIGH level input voltage		–	3.4	–	V
$t_{sw}$	switching time from 0 to 4.5 V	2 $\Omega$ load at MOS outputs	–	1	–	$\mu\text{s}$

Modulator for GaAs power amplifiers

UBA1710M

APPLICATION INFORMATION

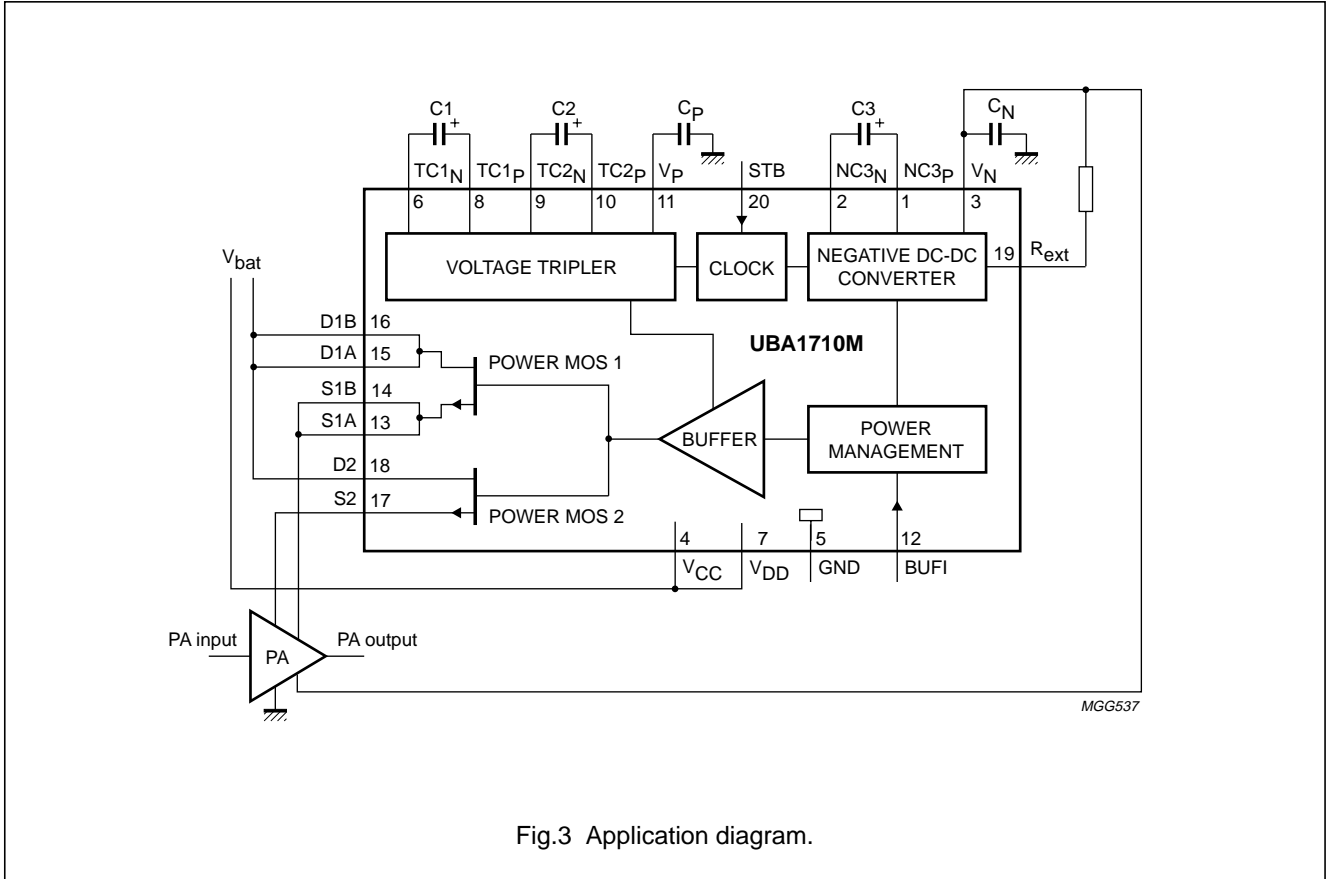

Fig.3 Application diagram.

Modulator for GaAs power amplifiers

UBA1710M

PACKAGE OUTLINE

SSOP20: plastic shrink small outline package; 20 leads; body width 4.4 mm

SOT266-1

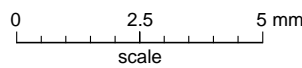
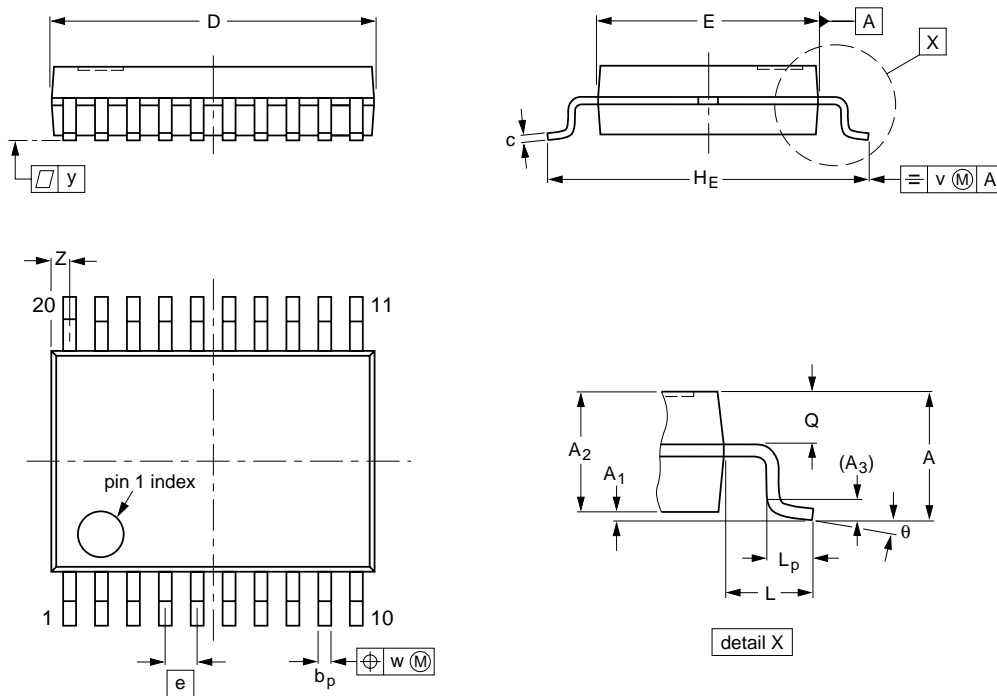

DIMENSIONS (mm are the original dimensions)

UNIT	A max.	A <sub>1</sub>	A <sub>2</sub>	A <sub>3</sub>	b <sub>p</sub>	c	D <sup>(1)</sup>	E <sup>(1)</sup>	e	H <sub>E</sub>	L	L <sub>p</sub>	Q	v	w	y	Z <sup>(1)</sup>	θ
mm	1.5	0.15 0	1.4 1.2	0.25	0.32 0.20	0.20 0.13	6.6 6.4	4.5 4.3	0.65	6.6 6.2	1.0	0.75 0.45	0.65 0.45	0.2	0.13	0.1	0.48 0.18	10° 0°

Note

1. Plastic or metal protrusions of 0.20 mm maximum per side are not included.

OUTLINE VERSION	REFERENCES				EUROPEAN PROJECTION	ISSUE DATE
	IEC	JEDEC	EIAJ			
SOT266-1						90-04-05 95-02-25

---

## Modulator for GaAs power amplifiers

UBA1710M

---

### SOLDERING

#### Introduction

There is no soldering method that is ideal for all IC packages. Wave soldering is often preferred when through-hole and surface mounted components are mixed on one printed-circuit board. However, wave soldering is not always suitable for surface mounted ICs, or for printed-circuits with high population densities. In these situations reflow soldering is often used.

This text gives a very brief insight to a complex technology. A more in-depth account of soldering ICs can be found in our *"IC Package Databook"* (order code 9398 652 90011).

#### Reflow soldering

Reflow soldering techniques are suitable for all SSOP packages.

Reflow soldering requires solder paste (a suspension of fine solder particles, flux and binding agent) to be applied to the printed-circuit board by screen printing, stencilling or pressure-syringe dispensing before package placement.

Several techniques exist for reflowing; for example, thermal conduction by heated belt. Dwell times vary between 50 and 300 seconds depending on heating method. Typical reflow temperatures range from 215 to 250 °C.

Preheating is necessary to dry the paste and evaporate the binding agent. Preheating duration: 45 minutes at 45 °C.

#### Wave soldering

Wave soldering is **not** recommended for SSOP packages. This is because of the likelihood of solder bridging due to closely-spaced leads and the possibility of incomplete solder penetration in multi-lead devices.

If wave soldering cannot be avoided, the following conditions must be observed:

- **A double-wave (a turbulent wave with high upward pressure followed by a smooth laminar wave) soldering technique should be used.**
- **The longitudinal axis of the package footprint must be parallel to the solder flow and must incorporate solder thieves at the downstream end.**

**Even with these conditions, only consider wave soldering SSOP packages that have a body width of 4.4 mm, that is SSOP16 (SOT369-1) or SSOP20 (SOT266-1).**

During placement and before soldering, the package must be fixed with a droplet of adhesive. The adhesive can be applied by screen printing, pin transfer or syringe dispensing. The package can be soldered after the adhesive is cured.

Maximum permissible solder temperature is 260 °C, and maximum duration of package immersion in solder is 10 seconds, if cooled to less than 150 °C within 6 seconds. Typical dwell time is 4 seconds at 250 °C.

A mildly-activated flux will eliminate the need for removal of corrosive residues in most applications.

#### Repairing soldered joints

Fix the component by first soldering two diagonally-opposite end leads. Use only a low voltage soldering iron (less than 24 V) applied to the flat part of the lead. Contact time must be limited to 10 seconds at up to 300 °C. When using a dedicated tool, all other leads can be soldered in one operation within 2 to 5 seconds between 270 and 320 °C.



## Modulator for GaAs power amplifiers

UBA1710M

**DEFINITIONS**

<b>Data sheet status</b>	
Objective specification	This data sheet contains target or goal specifications for product development.
Preliminary specification	This data sheet contains preliminary data; supplementary data may be published later.
Product specification	This data sheet contains final product specifications.
<b>Limiting values</b>	
Limiting values given are in accordance with the Absolute Maximum Rating System (IEC 134). Stress above one or more of the limiting values may cause permanent damage to the device. These are stress ratings only and operation of the device at these or at any other conditions above those given in the Characteristics sections of the specification is not implied. Exposure to limiting values for extended periods may affect device reliability.	
<b>Application information</b>	
Where application information is given, it is advisory and does not form part of the specification.	

**LIFE SUPPORT APPLICATIONS**

These products are not designed for use in life support appliances, devices, or systems where malfunction of these products can reasonably be expected to result in personal injury. Philips customers using or selling these products for use in such applications do so at their own risk and agree to fully indemnify Philips for any damages resulting from such improper use or sale.

Modulator for GaAs power amplifiers

UBA1710M

---

**NOTES**

Modulator for GaAs power amplifiers

UBA1710M

---

**NOTES**

# Philips Semiconductors – a worldwide company

**Argentina:** see South America

**Australia:** 34 Waterloo Road, NORTH RYDE, NSW 2113,  
Tel. +61 2 9805 4455, Fax. +61 2 9805 4466

**Austria:** Computerstr. 6, A-1101 WIEN, P.O. Box 213, Tel. +43 160 1010,  
Fax. +43 160 101 1210

**Belarus:** Hotel Minsk Business Center, Bld. 3, r. 1211, Volodarski Str. 6,  
220050 MINSK, Tel. +375 172 200 733, Fax. +375 172 200 773

**Belgium:** see The Netherlands

**Brazil:** see South America

**Bulgaria:** Philips Bulgaria Ltd., Energoproject, 15th floor,  
51 James Bourchier Blvd., 1407 SOFIA,  
Tel. +359 2 689 211, Fax. +359 2 689 102

**Canada:** PHILIPS SEMICONDUCTORS/COMPONENTS,  
Tel. +1 800 234 7381

**China/Hong Kong:** 501 Hong Kong Industrial Technology Centre,  
72 Tat Chee Avenue, Kowloon Tong, HONG KONG,  
Tel. +852 2319 7888, Fax. +852 2319 7700

**Colombia:** see South America

**Czech Republic:** see Austria

**Denmark:** Prags Boulevard 80, PB 1919, DK-2300 COPENHAGEN S,  
Tel. +45 32 88 2636, Fax. +45 31 57 0044

**Finland:** Sinikalliontie 3, FIN-02630 ESPOO,  
Tel. +358 9 615800, Fax. +358 9 61580920

**France:** 4 Rue du Port-aux-Vins, BP317, 92156 SURESNES Cedex,  
Tel. +33 1 40 99 6161, Fax. +33 1 40 99 6427

**Germany:** Hammerbrookstraße 69, D-20097 HAMBURG,  
Tel. +49 40 23 53 60, Fax. +49 40 23 536 300

**Greece:** No. 15, 25th March Street, GR 17778 TAVROS/ATHENS,  
Tel. +30 1 4894 339/239, Fax. +30 1 4814 240

**Hungary:** see Austria

**India:** Philips INDIA Ltd, Band Box Building, 2nd floor,  
254-D, Dr. Annie Besant Road, Worli, MUMBAI 400 025,  
Tel. +91 22 493 8541, Fax. +91 22 493 0966

**Indonesia:** see Singapore

**Ireland:** Newstead, Clonskeagh, DUBLIN 14,  
Tel. +353 1 7640 000, Fax. +353 1 7640 200

**Israel:** RAPAC Electronics, 7 Kehilat Saloniki St, PO Box 18053,  
TEL AVIV 61180, Tel. +972 3 645 0444, Fax. +972 3 649 1007

**Italy:** PHILIPS SEMICONDUCTORS, Piazza IV Novembre 3,  
20124 MILANO, Tel. +39 2 6752 2531, Fax. +39 2 6752 2557

**Japan:** Philips Bldg 13-37, Kohnan 2-chome, Minato-ku, TOKYO 108,  
Tel. +81 3 3740 5130, Fax. +81 3 3740 5077

**Korea:** Philips House, 260-199 Itaewon-dong, Yongsan-ku, SEOUL,  
Tel. +82 2 709 1412, Fax. +82 2 709 1415

**Malaysia:** No. 76 Jalan Universiti, 46200 PETALING JAYA, SELANGOR,  
Tel. +60 3 750 5214, Fax. +60 3 757 4880

**Mexico:** 5900 Gateway East, Suite 200, EL PASO, TEXAS 79905,  
Tel. +9-5 800 234 7381

**Middle East:** see Italy

**Netherlands:** Postbus 90050, 5600 PB EINDHOVEN, Bldg. VB,  
Tel. +31 40 27 82785, Fax. +31 40 27 88399

**New Zealand:** 2 Wagener Place, C.P.O. Box 1041, AUCKLAND,  
Tel. +64 9 849 4160, Fax. +64 9 849 7811

**Norway:** Box 1, Manglerud 0612, OSLO,  
Tel. +47 22 74 8000, Fax. +47 22 74 8341

**Philippines:** Philips Semiconductors Philippines Inc.,  
106 Valero St. Salcedo Village, P.O. Box 2108 MCC, MAKATI,  
Metro MANILA, Tel. +63 2 816 6380, Fax. +63 2 817 3474

**Poland:** Ul. Lukiska 10, PL 04-123 WARSZAWA,  
Tel. +48 22 612 2831, Fax. +48 22 612 2327

**Portugal:** see Spain

**Romania:** see Italy

**Russia:** Philips Russia, Ul. Usatcheva 35A, 119048 MOSCOW,  
Tel. +7 095 755 6918, Fax. +7 095 755 6919

**Singapore:** Lorong 1, Toa Payoh, SINGAPORE 1231,  
Tel. +65 350 2538, Fax. +65 251 6500

**Slovakia:** see Austria

**Slovenia:** see Italy

**South Africa:** S.A. PHILIPS Pty Ltd., 195-215 Main Road Martindale,  
2092 JOHANNESBURG, P.O. Box 7430 Johannesburg 2000,  
Tel. +27 11 470 5911, Fax. +27 11 470 5494

**South America:** Rua do Rocio 220, 5th floor, Suite 51,  
04552-903 São Paulo, SÃO PAULO - SP, Brazil,  
Tel. +55 11 821 2333, Fax. +55 11 829 1849

**Spain:** Balmes 22, 08007 BARCELONA,  
Tel. +34 3 301 6312, Fax. +34 3 301 4107

**Sweden:** Kottbygatan 7, Akalla, S-16485 STOCKHOLM,  
Tel. +46 8 632 2000, Fax. +46 8 632 2745

**Switzerland:** Allmendstrasse 140, CH-8027 ZÜRICH,  
Tel. +41 1 488 2686, Fax. +41 1 481 7730

**Taiwan:** Philips Semiconductors, 6F, No. 96, Chien Kuo N. Rd., Sec. 1,  
TAIPEI, Taiwan Tel. +886 2 2134 2865, Fax. +886 2 2134 2874

**Thailand:** PHILIPS ELECTRONICS (THAILAND) Ltd.,  
209/2 Sanpavuth-Bangna Road Prakanong, BANGKOK 10260,  
Tel. +66 2 745 4090, Fax. +66 2 398 0793

**Turkey:** Talatpasa Cad. No. 5, 80640 GÜLTEPE/ISTANBUL,  
Tel. +90 212 279 2770, Fax. +90 212 282 6707

**Ukraine:** PHILIPS UKRAINE, 4 Patrice Lumumba str., Building B, Floor 7,  
252042 KIEV, Tel. +380 44 264 2776, Fax. +380 44 268 0461

**United Kingdom:** Philips Semiconductors Ltd., 276 Bath Road, Hayes,  
MIDDLESEX UB3 5BX, Tel. +44 181 730 5000, Fax. +44 181 754 8421

**United States:** 811 East Arques Avenue, SUNNYVALE, CA 94088-3409,  
Tel. +1 800 234 7381

**Uruguay:** see South America

**Vietnam:** see Singapore

**Yugoslavia:** PHILIPS, Trg N. Pasica 5/v, 11000 BEOGRAD,  
Tel. +381 11 625 344, Fax. +381 11 635 777

**For all other countries apply to:** Philips Semiconductors, Marketing & Sales Communications,  
Building BE-p, P.O. Box 218, 5600 MD EINDHOVEN, The Netherlands, Fax. +31 40 27 24825

**Internet:** <http://www.semiconductors.philips.com>

© Philips Electronics N.V. 1997

SCA55

All rights are reserved. Reproduction in whole or in part is prohibited without the prior written consent of the copyright owner.

The information presented in this document does not form part of any quotation or contract, is believed to be accurate and reliable and may be changed without notice. No liability will be accepted by the publisher for any consequence of its use. Publication thereof does not convey nor imply any license under patent- or other industrial or intellectual property rights.

Printed in The Netherlands

437027/1200/03/pp12

Date of release: 1997 Oct 17

Document order number: 9397 750 02955

*Let's make things better.*

**Philips**  
Semiconductors



**PHILIPS**