

UBA2013/L3

HB driver IC with PFC for fluorescent rings

Rev. 00.01 — 23 February 2007

Preliminary data sheet

1. General description

The UBA2013/L3 is a high voltage IC intended to drive and control fluorescent lamps. The IC can handle both cold and warm ignition of the lamp. It contains a T_{ON} -controlled PFC function, a half bridge controller circuit with level shifter and an internal bootstrap diode to drive an external half bridge. UBA2013/L3 also offers a functionality to properly handle fault conditions such as capacitive mode switching, end-of-lamp-life and overcurrent. UBA2013/L3 is designed for wide-input mains voltage (120 V - 277 V) applications.

2. Features

2.1 Half bridge

- Suitable for cold and warm ignition
- Adjustable preheat time
- Adjustable ignition voltage
- Integrated bootstrap function
- Protection for lamp failure and end-of-life
- Adjustable preheat current
- Single ignition attempt
- Automatic restart after relamping
- Protection for capacitive mode

2.2 PFC

- Three pin PFC controller using T_{ON} control
- Critical mode operation
- Overvoltage/overcurrent protection

3. Applications

The UBA2013/L3 can provide the drive and control function for a wide range of half bridge based ballast applications at different mains voltages.

4. Ordering information

Table 1. Ordering information

Type number	Package		Version
	Name	Description	
UBA2013T	SO16	plastic small outline package; 16 leads; body width 3.9mm	SOT109-1

5. Block diagram

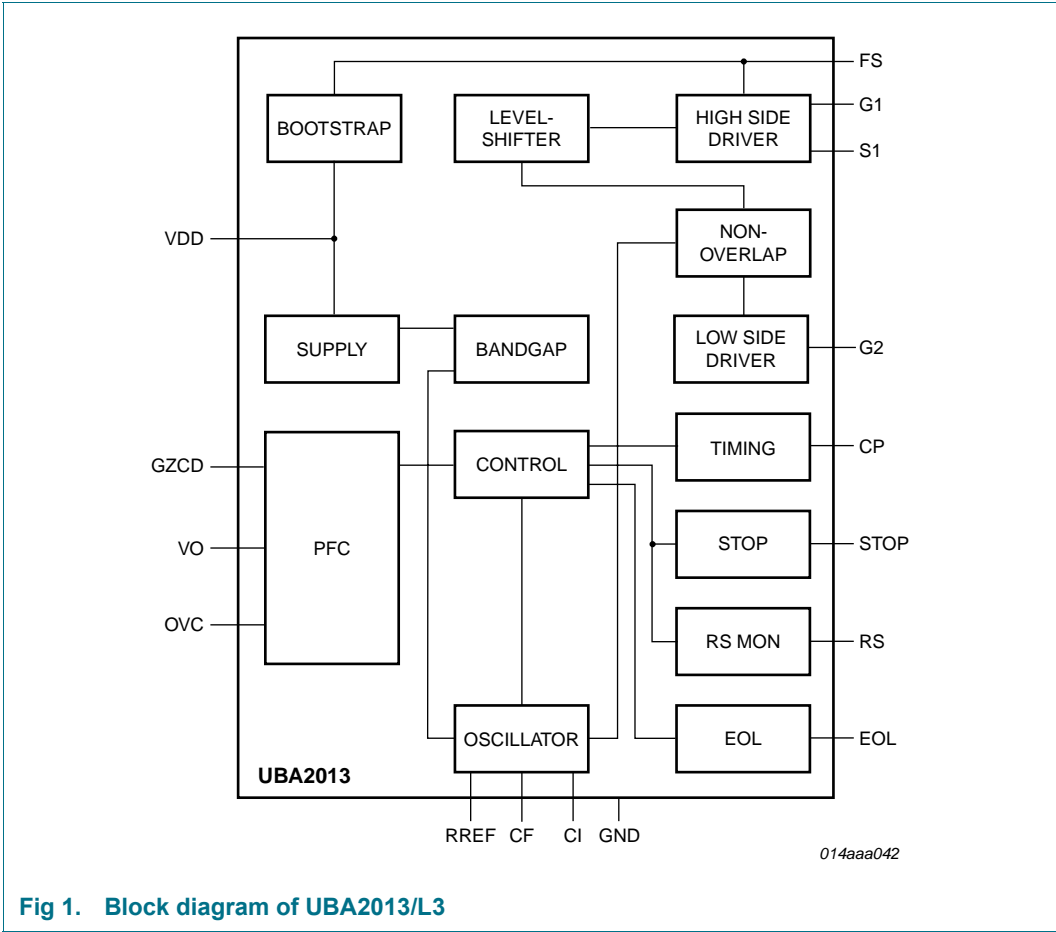

Fig 1. Block diagram of UBA2013/L3

6. Pinning information

6.1 Pinning

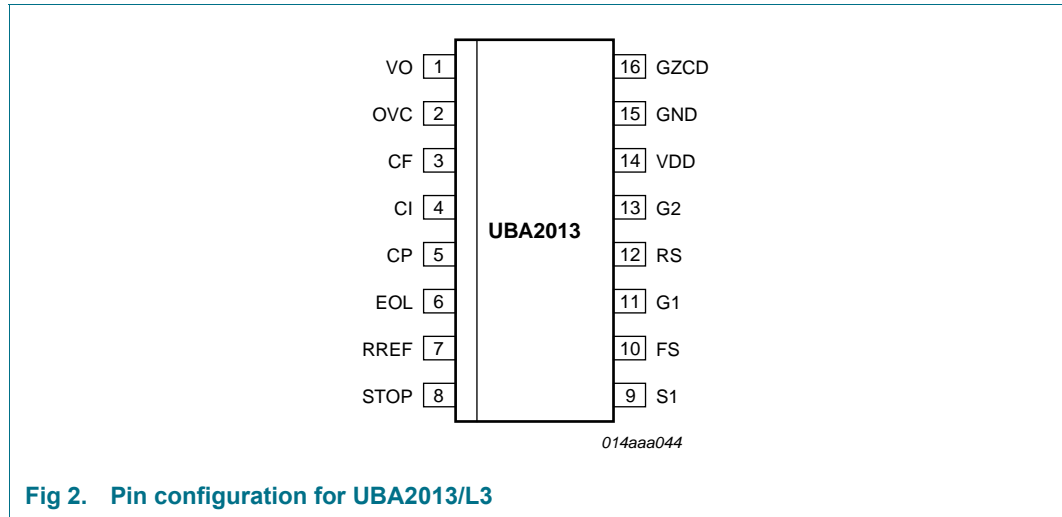

Fig 2. Pin configuration for UBA2013/L3

6.2 Pin description

Table 2. Pin description

Symbol	Pin	Description
VO	1	PFC output voltage sensing
OVC	2	PFC overvoltage/current
CF	3	Oscillator capacitor
CI	4	Integrating capacitor
CP	5	Timing capacitor
EOL	6	End-of-life
RREF	7	Reference resistor
STOP	8	Stop
S1	9	Source high side transistor (T1)
FS	10	High side floating supply
G1	11	Gate high side transistor (T1)
RS	12	Current sensor
G2	13	Gate low side transistor (T2)
VDD	14	Low voltage supply
GND	15	Ground
GZCD	16	PFC gate and ZCD

7. Functional description

7.1 Start-up state

Initial start up can be achieved by means of charging the VDD low voltage supply capacitor (C2 in the application diagram [Figure 6](#)) via an external start-up resistor. Start-up state is one of the non-oscillating sub-states. MOSFET T2 conducts and T1 is non-conducting, ensuring bootstrap capacitor C3 to be charged. In this state the circuit will be reset. The GZCD pin is pulled down and $I_{VO(ref)}$ is not active. If $V_{STOP} < V_{STOP(reset)}$ at the transition of V_{DD} exceeding $V_{DD(start)}$, the IC will enter the oscillating state. If not it will enter the stop state.

7.2 Half bridge oscillator

Oscillation of the half bridge is controlled by a built-in current-controlled oscillator which generates a sawtooth waveform at the CF pin. The sawtooth frequency is twice the half bridge frequency, and is determined by the capacitor at the CF pin and the current-out of pin CF, as controlled by the voltage at the CI pin. Frequency modulation is achieved by charging and discharging the CI capacitor. The IC brings MOSFETs T1 and T2 alternately into conduction with a duty factor of just below 50% each (except for situations where V_{RS} exceeds $V_{RS(clamp)}$). [Figure 3](#) represents the timing of the IC. The circuit block 'non-overlap' generates a non-overlap time t_{no} that ensures periods of exclusive conduction of T1 or T2. Time t_{no} depends on the reference current I_{RREF} .

7.3 Oscillating state

Oscillating state can be entered:

- when in the startup state $V_{STOP} < V_{STOP(reset)}$ at the moment V_{DD} reaches $V_{DD(start)}$,
- when in the VddLow state, when $V_{STOP} < V_{STOP(ref)}$ at the moment V_{DD} reaches $V_{DD(start)}$.

The oscillating state has three sub-states: the preheat state, the ignition state and the burn state. The circuit always starts oscillating in the preheat state.

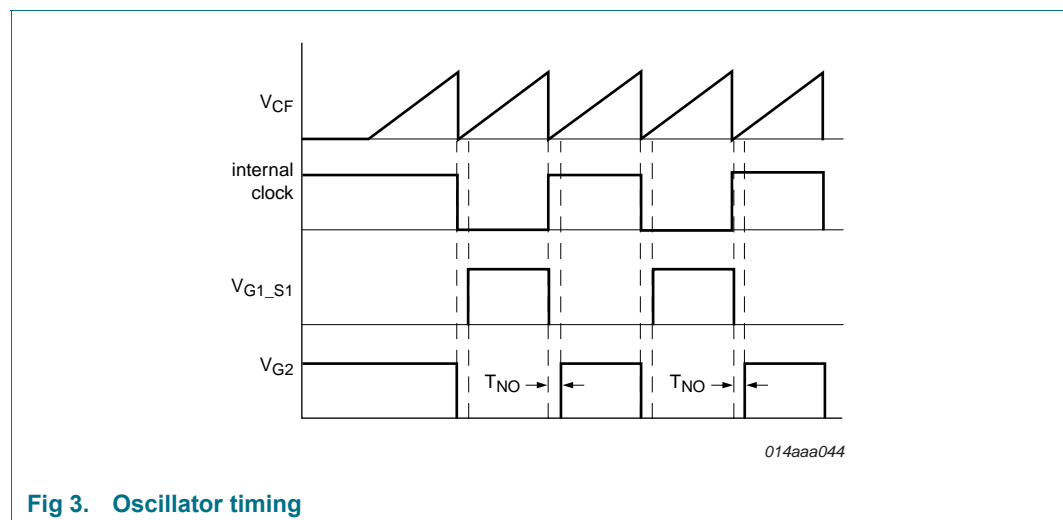

Fig 3. Oscillator timing

7.4 Preheat state

The circuit starts oscillating at the half-bridge frequency f_{start} (approximately $2.5 \times f_B$). The frequency gradually decreases until a user-defined value of the preheat current is reached. The slope of the decrease in frequency is determined by the capacitor at the CI pin. During preheat, the circuit monitors the inductor current by measuring the voltage across external resistor RS at the end of the conduction of T2 with decision level $V_{\text{RS(ph)}}$. The frequency is decreased for as long as $V_{\text{RS}} < V_{\text{RS(ph)}}$. The frequency is increased for $V_{\text{RS}} > V_{\text{RS(ph)}}$. During preheat the STOP pin is discharged to ground via a switch with an on resistance of $R_{\text{STOP(disch)}}$. The cycle-by-cycle excess charge control mechanism described in the ignition state is not active during the preheat state. The preheat time is determined by capacitor CP. For cold ignition the preheat time can be reduced by choosing a smaller CP capacitor. The circuit can be locked in the preheat state by connecting pin CP to ground.

7.5 Ignition state

After the preheat time the ignition state is entered and the frequency will sweep down due to charging of the capacitor at the CI pin with the internally fixed current $I_{\text{CI(charge)}}$. During this decrease in frequency, the circuit approaches the resonance frequency of the load. This will cause a high voltage across the load, which normally ignites the lamp.

In order to limit voltages and currents in the resonant circuit in case of non- or delayed ignition, a cycle-by-cycle excess charge control mechanism is used to prevent deep saturation and to limit the lamp voltage. When the voltage at pin RS exceeds $V_{\text{RS(clamp)}}$ the impedance of the pin changes from essentially infinite to essentially zero. If a current is flowing into pin RS during the on-state of T2, a fraction k_{Isat} of that current will be fed into the capacitor C_{CF} at pin CF in addition to the oscillator current already flowing into C_{CF} . The amount of current fed into C_{CF} depends on the voltage across RS and the value of resistor R, see [Figure 4](#). The increased current rapidly (but not instantly) ends the oscillator half-cycle, after which T2 is switched off. The on-time of T1 is not affected and thus the half bridge will run asymmetrically, see [Figure 4](#).

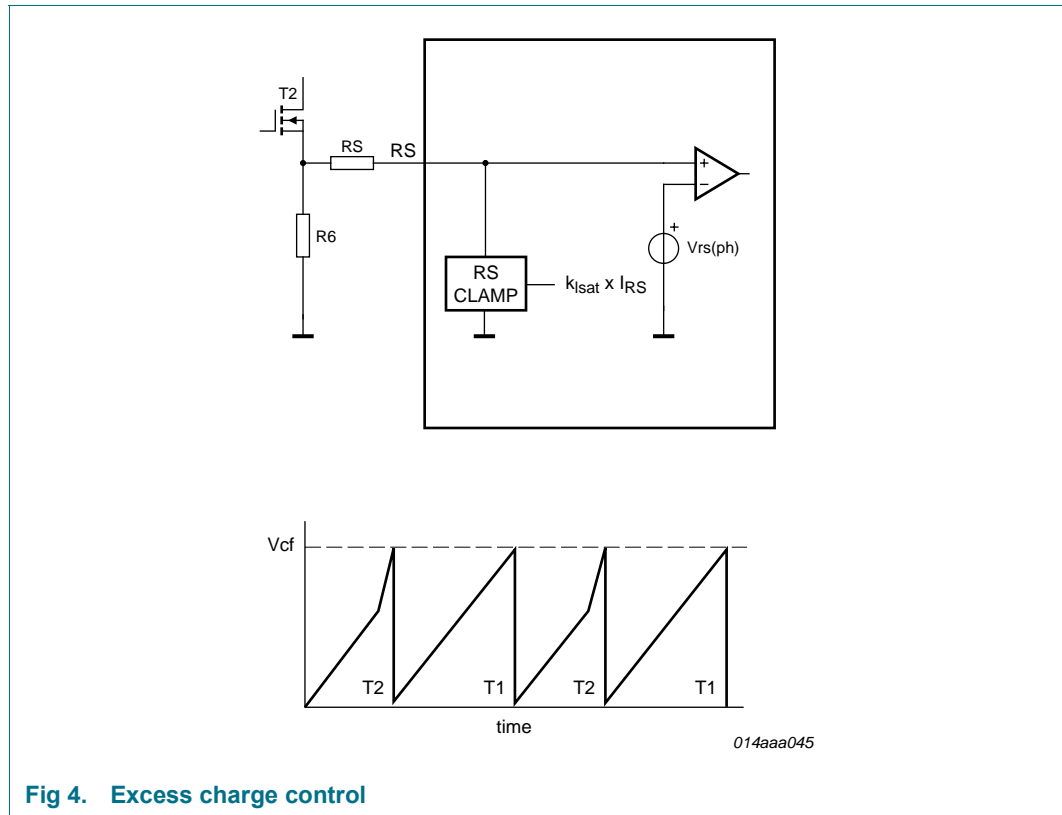

Fig 4. Excess charge control

7.6 Burn state

At the end of the ignition time, the burn state is entered. In this state the voltage at the CI pin will continue to increase until a clamp level is reached corresponding to the minimum frequency f_B . The circuit will continue to oscillate at the minimum frequency, unless capacitive mode is detected. In the burn state the CP pin is pulled to ground with a discharge impedance $R_{CP(disch)}$. The EOL protection is enabled. The excess charge control mechanism will remain active.

7.7 Capacitive mode protection

Capacitive mode protection is active in all oscillating states. The signal across resistor RS (R6 in the application diagram of [Figure 6](#)) also gives information about the switching behavior of the half bridge. If the voltage across resistor RS is not below $V_{RS(cap)}$ at the moment of turn-on of T2, the capacitive mode detection circuit assumes the circuit to be in capacitive mode. Upon capacitive mode detection CI is gradually discharged and instantly the frequency gradually increases as long as capacitive mode is detected. The frequency decreases gradually down to the minimum frequency if no capacitive mode is detected. Detecting capacitive mode at the maximum frequency will activate the internal current $I_{STOP(ch)}$ that charges the STOP pin.

7.8 Stop function

For all oscillating states the IC will enter the stop state for $V_{STOP} > V_{STOP(ref)}$. Note that there is no internal stop timing. An external stop timing can be obtained via the RC time of the network R4, R5 and C11, see the application diagram in [Figure 6](#). During preheat the

STOP pin is discharged to ground via a switch with on-resistance $R_{\text{STOP}(\text{disch})}$. In case of a VO-low condition (see [Section 7.15](#)), the STOP pin is discharged with a current $I_{\text{STOP}(\text{dis})}$. Apart from the preheat state or a VO-low condition, the IC will not discharge the STOP pin at any VDD.

7.9 End-of-life protection

The end-of-life circuit is only active in the burn state and consists of a voltage window comparator circuit. It compares the voltage at the EOL pin with two internal reference voltages. When the voltage at the EOL pin is above $V_{\text{EOL}(\text{high})}$ or below $V_{\text{EOL}(\text{low})}$ the 'end-of-life' protection circuit activates the internal current source $I_{\text{STOP}(\text{ch})}$ that charges the STOP pin. The 'end-of-life' protection is not active in case of a VO-low condition (see [Section 7.15](#)).

7.10 Non-oscillating state

Transitions to the non-oscillating state are always made during a G2 high condition in the half bridge (lower MOSFET T2 conducting). In the non-oscillating state T1 is off, T2 is on, the PFC control function is stopped by pulling the GZCD pin down to ground continuously, and reference current $I_{V_{\text{O}}(\text{ref})}$ is switched off. Additionally, the CP and CI pins are discharged to ground. The non-oscillating state has three sub-states: the start-up state, the stop state and the VddLow state.

7.11 Start-up state

Described at the beginning of this functional description.

7.12 Stop state

The circuit will enter the stop state:

- when in any of the oscillating states $V_{\text{STOP}} > V_{\text{STOP}(\text{ref})}$,
- when in the VddLow state $V_{\text{STOP}} > V_{\text{STOP}(\text{ref})}$ at the moment V_{DD} exceeds $V_{\text{DD}(\text{start})}$,
- when in the startup state $V_{\text{STOP}} > V_{\text{STOP}(\text{reset})}$ at the moment V_{DD} exceeds $V_{\text{DD}(\text{start})}$.

In the stop state, a clamp circuit is active, limiting the voltage at the VDD pin to $V_{\text{DD}(\text{clamp})}$. The IC goes from the stop state into the startup state if V_{DD} drops below $V_{\text{DD}(\text{reset})}$.

7.13 VddLow state

The circuit will enter VddLow state in any of the oscillating states when V_{DD} drops below $V_{\text{DD}(\text{low})}$. The circuit then goes from VddLow state to:

- the startup state if V_{DD} drops below $V_{\text{DD}(\text{reset})}$,
- the stop state if $V_{\text{STOP}} > V_{\text{STOP}(\text{ref})}$ at the moment V_{DD} exceeds $V_{\text{DD}(\text{start})}$, or
- the preheat state if $V_{\text{STOP}} < V_{\text{STOP}(\text{ref})}$ at the moment V_{DD} exceeds $V_{\text{DD}(\text{start})}$.

7.14 PFC function

The internal PFC control block provides a T_{ON} controlled, critical mode power factor correction controller. The T_{ON} is set by the voltage at the VO pin. The duration of the T_{ON} pulse decreases linearly with increasing V_{VO} . The V_{VO} voltage is the result of an error current through the compensation impedance connected at the VO pin. This error current is the difference between a current proportional to the output voltage of the PFC pulling the VO pin high and an internal reference current $I_{VO(ref)}$ pulling the VO pin low.

The external MOSFET is primarily driven via the secondary winding on the inductor L_{P1} . The T_{ON} timing starts the moment V_{GZCD} exceeds $V_{GZCD(start)}$ (below the threshold of the external MOSFET). The external MOSFET is turned on and current builds up in the inductor L_{P1} . At the end of T_{ON} the output driver pulls the GZCD pin down during a defined time T_{OFF} . This turns off the external MOSFET. The inductor current I_{LP1} now flows through the boost diode DP2. The polarity of the voltage across the secondary winding changes to negative, keeping the external MOSFET in the off state. As long as V_{GZCD} is below $V_{GZCD(start)}$ the T_{ON} timing is reset. The current in the inductor decreases linearly to below zero. Just after the zero crossing the polarity of the voltage across the secondary winding becomes positive and makes V_{GZCD} exceed $V_{GZCD(start)}$, starting the T_{ON} timing, turning on the external MOSFET and completing the cycle.

T_{ON} varies linearly from $T_{ON(max)}$ to $T_{ON(min)}$ in the range of V_{VO} from $V_{VO(low)}$ to $V_{VO(low)} + \Delta V_{VO}$. Above a voltage $V_{VO(off)}$ ($> V_{VO(low)} + \Delta V_{VO}$) at the VO pin, T_{ON} is zero and the GZCD pin is continuously pulled down.

The OVC pin is intended for over-voltage and/or over-current protection. The voltage at the OVC pin is compared to a reference voltage $V_{OVC(ref)}$. For $V_{OVC} > V_{OVC(ref)}$ the GZCD pin is pulled down within a time T_{OVC} . As long as $V_{OVC} > V_{OVC(ref)}$ the GZCD pin will be continuously pulled down by the output driver. Additionally, the OVC pin provides protection against an accidental open circuit of the external OVC divider of the PFC output voltage. As long as $V_{OVC} < V_{OVC(low)}$ the GZCD pin is continuously pulled down by the output driver.

In order to prevent persistent ambiguous drive signals for the external MOSFET, for $V_{GZCD} > V_{GZCD(start)}$ the GZCD pin is charged after a delay of T_{GZCD} with a current of $I_{GZCD(on)}$ up to a voltage of $V_{GZCD(active)}$ (above the threshold of the external MOSFET). Note that the voltage at the GZCD pin is not clamped at $V_{GZCD(active)}$: the secondary winding on the inductor L_{P1} can take the GZCD pin up to V_{DD} .

The PFC function is self-starting by means of a current source $I_{GZCD(start)}$ ($\ll I_{GZCD(on)}$) which, under oscillation conditions, continuously charges the GZCD pin. In any of the non-oscillating states the current sources $I_{GZCD(start)}$ and $I_{VO(ref)}$ are off and the GZCD pin is continuously pulled down. In oscillating conditions the positive voltage at the VO pin is clamped at a level $V_{VO(clamp)}$: in non-oscillating conditions, the positive voltage at the VO pin is clamped at a level $< V_{VO(off)}$.

7.15 VO-low condition

In order to prevent unintended stopping in case of the mains voltage being too low for the PFC stage to maintain its intended output voltage, this condition is detected in the oscillating state by the current sunk into the VO pin dropping below $k_{VO} * I_{VO(ref)}$, where the constant k_{VO} represents a fraction (typ. 95%) of $I_{VO(ref)}$. In case of a VO-low condition:

- the end-of-life protection is deactivated,

- the stop level is effectively raised by discharging the STOP pin with a current $I_{STOP(dis)}$.

The VO-low condition is overruled when $V_{OVC} < V_{OVC(low)}$.

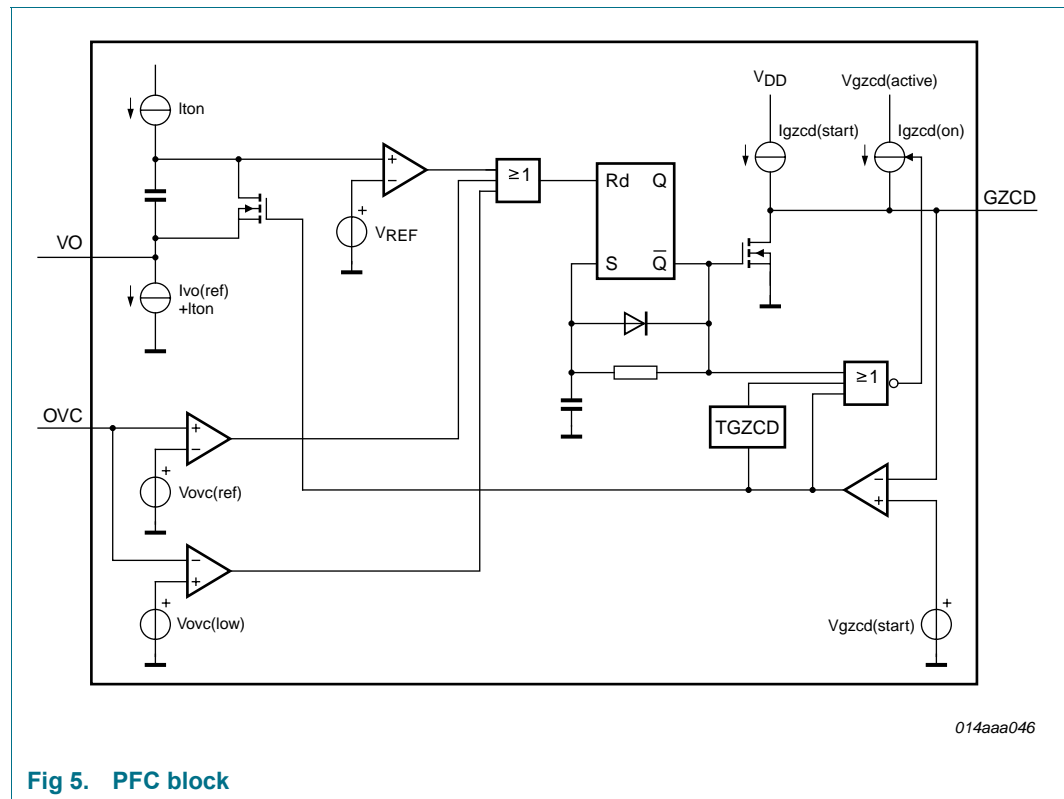

Fig 5. PFC block

7.16 State and transition diagrams

See [Section 16.1](#).

7.17 Charge coupling

Via parasitic capacitive coupling to high-voltage AC signals present in the application, a repetitive AC charge injection might occur at the IC-pins. In the typical application of [Figure 6](#), the pins R_{REF} and C_F are most sensitive to this charge injection. For a charge coupling of Q_{coupl} , safe functional operation of the IC is guaranteed, irrespective of the current level. Charge coupling at current levels below $50 \mu A$ will not interfere with the accuracy of the $V_{RS(cap)}$ and $V_{RS(ph)}$ levels. Charge coupling at current levels below $20 \mu A$ will not interfere with the accuracy of any parameter.

8. Limiting values

Table 3. Limiting values

Symbol	Parameter	Conditions	Min	Max	Unit
V_{FS}	High-side floating supply voltage	Operating $t < 0.5s$	0	570 630	V
V_{RS}	Voltage at pin RS		[3] 0	V_{BE}	V
I_{RS}	Current in pin RS	$t < 1.0\mu s$	[4] -10	10	mA
V_{G1}	Voltage at pin G1		[3] $V_{S1} - V_{BE}$	V_{FS}	V
V_{G2}	Voltage at pin G2		[3] $-V_{BE}$	V_{VDD}	V
V_{VDD}	Low-voltage supply	$t < 0.5s$ over lifetime	0	15	V
V_{VDD}	Low-voltage supply	In stop state	0	14	V
I_{VDD}	Clamp current in pin VDD			5	mA
V_{GZCD}	Voltage at pin GZCD		[3] $-V_{BE}$	V_{VDD}	V
V_{OVC}	Voltage at pin OVC		0	5	V
I_{VO}	Current in pin VO	$V_{VDD} = 0V$ to V_{VDDmax}	0	200	μA
I_{CF}	Current in pin CF	$V_{VDD} = 0V$ to V_{VDDmax}	0	200	μA
I_{EOL}	Current in pin EOL	$V_{VDD} = 0V$ to V_{VDDmax}	-1	1	mA
SR	Slew rate at pins S1, G1 and FS	With respect to ground	-4	4	V/ns
T_j	Junction temperature		-25	150	$^{\circ}C$
T_{amb}	Ambient temperature		-25	100	$^{\circ}C$
T_{stg}	Storage temperature		-55	150	$^{\circ}C$
$V_{esd(HBM)}$	HBM electrostatic handling voltage		[1]		
	pin EOL and G1			<500	V
	pins FS, S1, VDD and G2			1000	V
	pins VO, OVC, CF, CI, CP, RREF, STOP, RS, GZCD			2000	V
$V_{esd(MM)}$	MM electrostatic handling voltage		[2]		
	pin EOL			50	V
	pins FS, G1, S1, VDD and G2			100	V
	pins VO, OVC, CF, CI, CP, RREF, STOP, RS, GZCD			200	V
Q_{coupl}	Charge coupling at pins RREF and CF	Operating	-8	8	pC
R_{RREF}	Reference resistor		22	47	k Ω

[1] In accordance with the Human Body Model (HBM): i.e. equivalent to discharging a 100 pF capacitor through a 1.5 k Ω series resistor.

[2] In accordance with the Machine Model (MM): i.e. equivalent to discharging a 200 pF capacitor through a 10 Ω series resistor and a 0.75 μH inductor.

[3] At $T_{amb} = 25\text{ }^{\circ}\text{C}$ the typical V_{BE} is 0.7 V.

[4] At negative RS currents (typ. < -5 mA) capacitive-mode protection can be triggered.

9. Thermal characteristics

Table 4. Thermal characteristics

Symbol	Parameter	Conditions	Typ	Unit
$R_{th(j-a)}$	thermal resistance from junction to ambient SO16	in free air	100	K/W
$R_{th(j-pin)}$	thermal resistance from junction to pin SO16	in free air	50	K/W

10. Characteristics

Table 5. Characteristics

$T_{amb} = 25\text{ }^{\circ}\text{C}$; $V_{DD} = 13.0\text{ V}$; $C_{CF} = 100\text{ pF}$; $R_{RREF} = 33\text{ k}\Omega$; $C_{CP} = 100\text{ nF}$; $C_{CI} = 100\text{ nF}$; all voltages referenced to ground unless otherwise specified.

Symbol	Parameter	Conditions	Min	Typ	Max	Unit
High-voltage supply						
I_{L1}	Leakage current: high-voltage pins	FS, G1, S1 = 630 V, $V_{DD} = 0\text{ V}$			15	μA
Start-up state						
$V_{DD(start)}$	Start of oscillation		12.1	12.6	13.1	V
$V_{DD(low)}$	Stop of oscillation		9.7	10.2	10.7	V
$V_{DD(hys)}$	Start-stop hysteresis		2.2	2.4	2.6	V
$I_{VDD(nonosc)}$	Non-oscillating current	$V_{DD} = 12\text{ V}$ [2]	100	150	200	μA
$V_{DD(clamp)}$	Clamp voltage VDD	At 5 mA non-oscillating	10.0	12.0	14.0	V
$V_{DD(reset)}$	Reset voltage	[10]	4.5	5.5	6.5	V
Preheat voltage						
f_{start}	Starting frequency	$V_{CI} = 0$ [1]	101	112.5	124	kHz
T_{PH}	Preheat time	$C_{CP} = 100\text{ nF}$	574	674	796	ms
$I_{CP(charge)}$	Charge current at CP pin	$V_{CP} = 1.0\text{ V}$		6.0		μA
$I_{CP(discharge)}$	Discharge current at CP pin	$V_{CP} = 3.5\text{ V}$		6.0		μA
$\Delta V_{CP(pk)}$	Peak voltage difference at CP pin	When timing		2.45		V
$V_{CP(min)}$	CP comparator level low		1.10	1.25		V
$V_{RS(ph)}$	Control voltage at RS pin	[5]	365	400	435	mV
Ignition state						
T_{IG}	Ignition time	$C_{CP} = 100\text{ nF}$	512	611	730	ms
$V_{RS(clamp)}$	Saturation current detection level	At $I_{RS(ig)} = 0.5\text{ mA}$		0.75		V
K_{Isat}	Saturation control current gain	[6]	0.45	0.50	0.55	A/A
Burn state						
f_B	Bottom frequency	[1]	43.6	45.0	46.4	kHz
T_{NO}	Non-overlap time		1.05	1.40	1.75	μs
SYM f_B	Symmetry half bridge	[1][9]	0.9	1.0	1.1	
SYM T_{NO}	Symmetry non-overlap time	[11]		1.0		

Table 5. Characteristics ...continued

$T_{amb} = 25\text{ }^{\circ}\text{C}$; $V_{DD} = 13.0\text{ V}$; $C_{CF} = 100\text{ pF}$; $R_{RREF} = 33\text{ k}\Omega$; $C_{CP} = 100\text{ nF}$; $C_{CI} = 100\text{ nF}$; all voltages referenced to ground unless otherwise specified.

Symbol	Parameter	Conditions	Min	Typ	Max	Unit	
I_{tot}	Total supply current		[1][7]	1.5	2.0	mA	
$I_{CI(charge)}$	Charge current at CI pin	$V_{CI} = 1.5\text{ V}$	36	44	52	μA	
$I_{CI(discharge)}$	Discharge current at CI pin	$V_{CI} = 1.5\text{ V}$	74	90	106	μA	
$\Delta I_{CF}/\Delta V_{CI}$	CI transconductance	$V_{CI} = 1.5\text{ V}$		12		$\mu\text{A/V}$	
$V_{RS(cap)}$	Capacitive-mode control voltage		[8]	-40	-20	0	mV
V_{RREF}	Reference voltage		2.425	2.500	2.575	V	
$V_{G1(on)}$	On voltage at pin G1	$ I_{G1} = 1\text{ mA}$	10.5			V	
$V_{G1(off)}$	Off voltage at pin G1	$ I_{G1} = 1\text{ mA}$			0.3	V	
$V_{G2(on)}$	On voltage at pin G2	$ I_{G2} = 1\text{ mA}$	10.5			V	
$V_{G2(off)}$	Off voltage at pin G2	$ I_{G2} = 1\text{ mA}$			0.3	V	
$R_{G1(on)}$	High side driver on resistance	$V_{(G1-S1)} = 3\text{ V}$		250		Ω	
$R_{G1(off)}$	High side driver off resistance	$V_{(G1-S1)} = 3\text{ V}$		35		Ω	
$R_{G2(on)}$	Low side driver on resistance	$V_{G2} = 3\text{ V}$		250		Ω	
$R_{G2(off)}$	Low side driver off resistance	$V_{G2} = 3\text{ V}$		35		Ω	
V_{drop}	Voltage drop at bootstrap switch	$I_{FS} = 5\text{ mA}$		2.0		V	
$R_{CP(disch)}$	On resistance switch at CP pin	$V_{CP} = 0.6\text{ V}$		120		Ω	
Stop and end-of-life							
$V_{STOP(ref)}$	Stop reference level		1.21	1.26	1.31	V	
$V_{STOP(reset)}$	Stop reset level		[10]	0.95	1.00	1.05	V
$V_{STOP(hys)}$	Stop hysteresis		[10]	0.20	0.25	0.30	V
$I_{STOP(ch)}$	Stop-charge current source	$V_{STOP} = 0.75\text{ V}$	2.0	2.5	3.0	μA	
$I_{STOP(dis)}$	Stop discharge current	$V_{STOP} = 0.75\text{ V}$	0.35	0.50	0.65	μA	
$R_{STOP(disch)}$	On resistance discharge switch	$V_{STOP} = 0.5\text{ V}$	1.0	2.5	4.0	$\text{k}\Omega$	
$V_{EOL(high)}$	High level end-of-life comparator		2.9	3.0	3.1	V	
$V_{EOL(low)}$	Low level end-of-life comparator		1.9	2.0	2.1	V	
Power-factor control							
$I_{VO(ref)}$	Output voltage reference current	$V_{VO} = 3.0\text{ V}$	97	102	107	μA	
$V_{OVC(ref)}$	OVC reference level		1.21	1.26	1.31	V	
T_{OVC}	Delay OVC comparator			60		ns	
$V_{VO(low)}$	VO offset voltage			1.0		V	
ΔV_{VO}	VO dynamic range			2.7		V	
$I_{GZCD(start)}$	Start-up current at GZCD pin	$V_{GZCD} = 0\text{ V}$	35	42.5	50	μA	
$I_{GZCD(on)}$	Turn on current at GZCD pin	$V_{GZCD} = 3\text{ V}$		12		μA	
$V_{GZCD(start)}$	GZCD start level		1.9	2.0	2.1	V	
$V_{GZCD(active)}$	GZCD active level	$I_{GZCD} = 0.5\text{ mA}$		6.4		V	
T_{GZCD}	GZCD turn on delay			0.5		μs	
$T_{ON(max)}$	Maximum on time	$V_{VO} = V_{VO(low)}$	[4]	20		μs	
$T_{ON(min)}$	Minimum on time	$V_{VO} = V_{VO(off)}$	[3][10]	0.4	0.5	μs	
$I_{GZCD(sink)}$	Gate drive sink current	$V_{GZCD} = 4\text{ V}$	200			mA	

Table 5. Characteristics ...continued

$T_{amb} = 25\text{ }^{\circ}\text{C}$; $V_{VDD} = 13.0\text{ V}$; $C_{CF} = 100\text{ pF}$; $R_{RREF} = 33\text{ k}\Omega$; $C_{CP} = 100\text{ nF}$; $C_{CI} = 100\text{ nF}$; all voltages referenced to ground unless otherwise specified.

Symbol	Parameter	Conditions	Min	Typ	Max	Unit
T_{OFF}	Duration off pulse			0.9		μs
$V_{OVC(low)}$	OVC low voltage			120		mV
k_{VO}	VO low factor		0.86	0.95	0.99	
$V_{VO(off)}$	Off voltage PFC			3.7		V
$V_{VO(clamp)}$	Active VO clamp voltage	$I_{VO} = 200\text{ }\mu\text{A}$		4.7		V
$V_{VO(pas)}$	Passive VO clamp voltage	$I_{VO} = 200\text{ }\mu\text{A}$, $V_{VDD} = 0\text{ V}$		3.9		V

- [1] Excluding situations where the excess charge control mechanism is active.
- [2] The non-oscillation current is specified in a temperature range of 0 to 100 °C. For $T_j < 0\text{ }^{\circ}\text{C}$ and $T_j > 100\text{ }^{\circ}\text{C}$ the maximum start-up current is 350 μA .
- [3] Minimum on-time is defined without the external MOSFET. V_{GZCD} is increased from 0 to 10 V in 1 μs . T_{ONmin} is defined as the time elapsed between V_{GZCD} exceeding $V_{GZCD(start)}$ and V_{GZCD} being pulled below 3 V at turn-off.
- [4] Maximum on-time is defined without the external MOSFET. Parameter is measured with $V_{VO} = V_{VO(low)}$ and V_{GZCD} is increased from 0 to 10 V in 1 μs . T_{ONmax} is defined as the time elapsed between V_{GZCD} exceeding $V_{GZCD(start)}$ and V_{GZCD} pulled below 3 V at turn-off.
- [5] Data sampling of $V_{RS(ph)}$ is performed at the end of conduction of T2 .
- [6] Gain is defined as I_{CF}/I_{RS} with $V_{RS} > V_{RS(clamp)}$.
- [7] Total supply current is specified in a T_j temperature range of -20 °C to 125 °C at f_B , excluding gate drive charge.
- [8] Data sampling of $V_{RS(cap)}$ is performed at the start of conduction of T2 .
- [9] The symmetry $SYM f_B$ is calculated from the quotient $SYM f_B = T_{1tot}/T_{2tot}$, with T_{1tot} being the time between turn-off of G2 and the turn-off of G1, and T_{2tot} the time between turn-off of G1 and the turn-off of G2.
- [10] Not measured, guaranteed by design.
- [11] The symmetry $SYM T_{NO}$ is defined as the ratio between $deadtime1$ and $deadtime2$. $Deadtime1$ is the time between turning off G1 and turning on G2. $Deadtime2$ is the time between turning off G2 and turning on G1.

11. Latch-up

Table 6. Latch-up
(Positive currents flow into pins)

Symbol	Parameter	Conditions	Min	Unit
$I_{latch\ up}$	Latch-up current		[1]	
	Pin RS		[1]	-30 mA
	Pin CF		[1]	-50 mA
	Pin STOP		[1]	-80 mA
	Pins VO, OVC, CI, CP, EOL, RREF, STOP, S1, FS, G1, G2, GZCD		[1]	-100 mA

- [1] Negative latch-up currents tested at $T_j = 150\text{ }^{\circ}\text{C}$ by discharging a 22 mF capacitor through a 50 Ω series resistor. Positive latch-up currents according to quality specification.

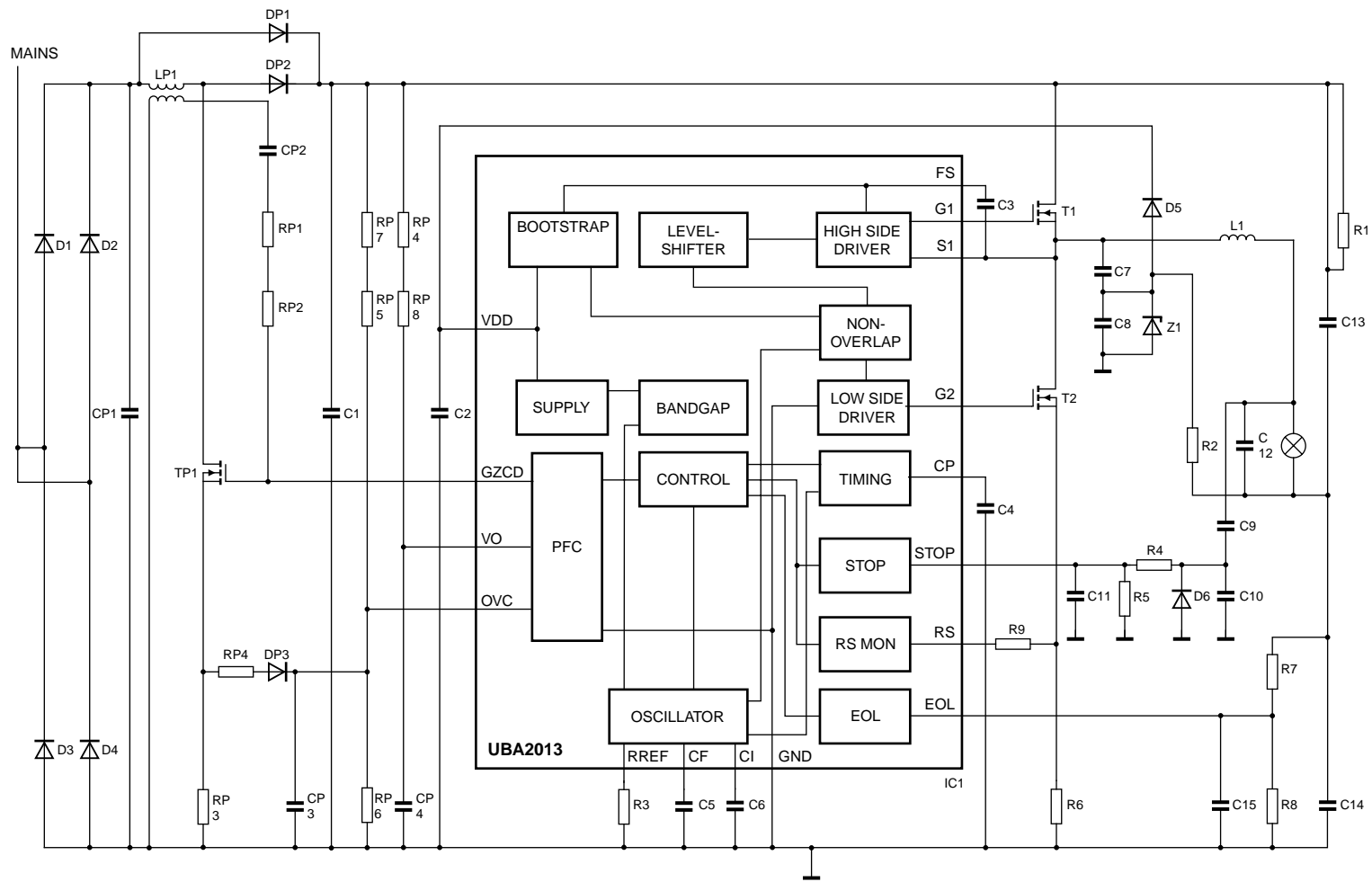

014aaa047

Fig 6. Application diagram of UBA2013L/3

12.1 Design equations

[Equation 1](#) through [Equation 5](#) give the design equations for the UBA2013:

Table 7. UBA2013 parameters (typical)

X1 = 3.24	Rint = 3 kΩ
t = 300ns	Cpar = 5 pF (typ)

Bottom frequency f_B is set by RREF and CF:

$$f_B = \frac{I}{2 \times \{[(C_{CF} + C_{par}) \times (X1 \times R_{RREF} - R_{int})] + \tau\}} \text{ (Hz)} \quad (1)$$

Preheat time T_{preh} is set by RREF and CP:

$$T_{preh} = 674 \times \frac{C_{CP}}{100 \text{ nF}} \times \frac{R_{RREF}}{33 \text{ k}\Omega} \text{ (ms)} \quad (2)$$

Ignition time T_{ign} is set by RREF and CP:

$$T_{ign} = 611 \times \frac{C_{CP}}{100 \text{ nF}} \times \frac{R_{RREF}}{33 \text{ k}\Omega} \text{ (ms)} \quad (3)$$

Non-overlap time T_{no} is set by RREF:

$$T_{no} = 0.15 + 1.25 \times \frac{R_{RREF}}{33 \text{ k}\Omega} \text{ (\mu s)} \quad (4)$$

PFC on-time T_{on} :

$$T_{ON}(V_{VO}) = T_{ON(max)} - \frac{(T_{ON(max)} - T_{ON(min)})}{\Delta V_{VO}} \times (V_{VO} - V_{VO(low)}) \quad (5)$$

13. Test information

The *General Quality Specification for Integrated Circuits SNW-FQ-611-E* is applicable.

14. Package outline

SO16: plastic small outline package; 16 leads; body width 3.9 mm

SOT109-1

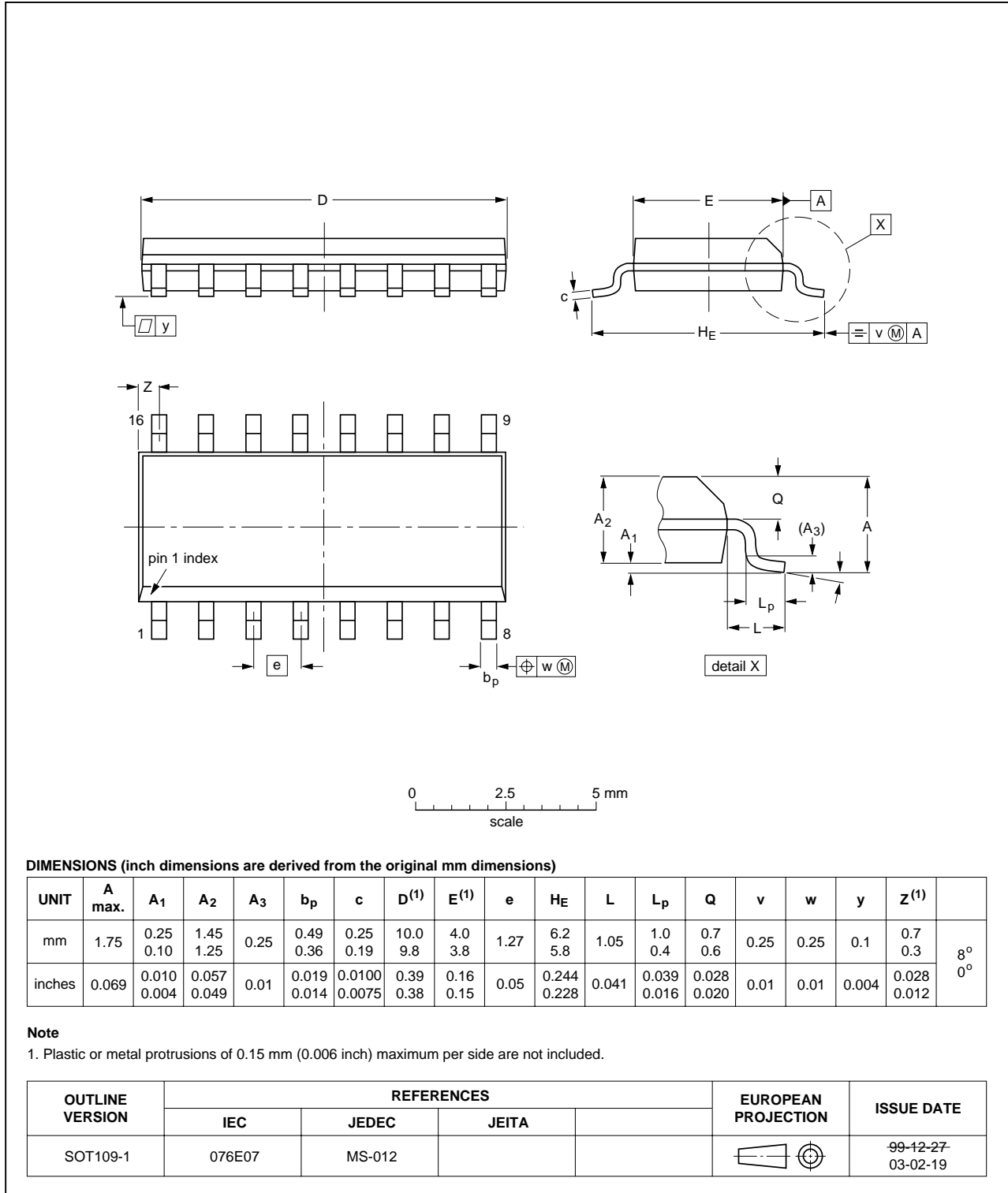
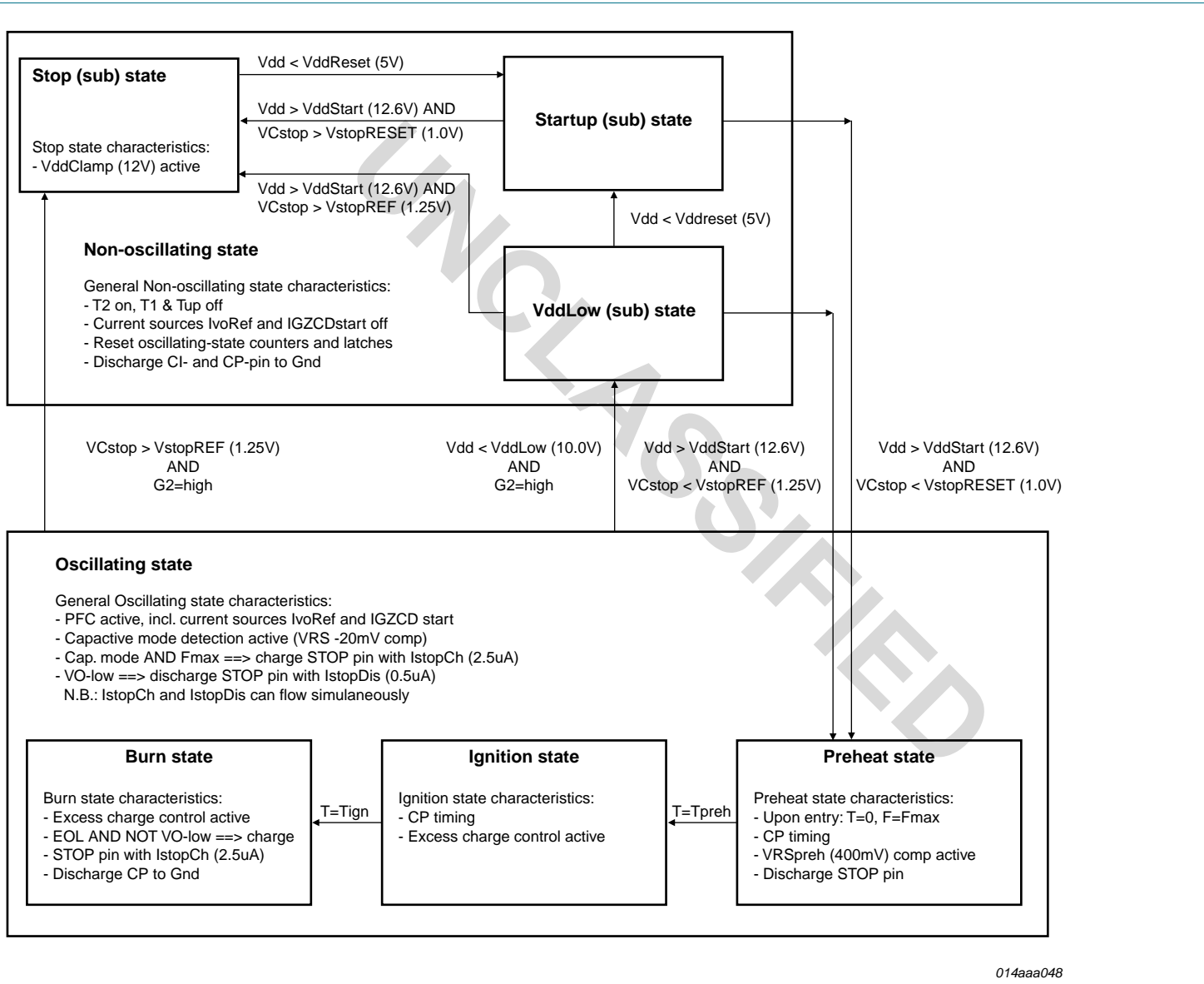

Fig 7. Package outline SOT109-1 (SO16)

15.1 State diagram and state transitions



014aaa048

Fig 8. State diagram and state transitions

16. Revision history

Table 8. Revision history

Document ID	Release date	Data sheet status	Change notice	Supersedes
UBA2013L_1	<yyyymmdd>	Objective data sheet	-	-

17. Legal information

17.1 Data sheet status

Document status ^{[1][2]}	Product status ^[3]	Definition
Objective (short) data sheet	Development	This document contains data from the objective specification for product development.

[1] Please consult the most recently issued document before initiating or completing a design.

[2] The term 'short data sheet' is explained in section "Definitions".

[3] The product status of device(s) described in this document may have changed since this document was published and may differ in case of multiple devices. The latest product status information is available on the Internet at URL <http://www.nxp.com>.

17.2 Definitions

Draft — The document is a draft version only. The content is still under internal review and subject to formal approval, which may result in modifications or additions. NXP Semiconductors does not give any representations or warranties as to the accuracy or completeness of information included herein and shall have no liability for the consequences of use of such information.

Short data sheet — A short data sheet is an extract from a full data sheet with the same product type number(s) and title. A short data sheet is intended for quick reference only and should not be relied upon to contain detailed and full information. For detailed and full information see the relevant full data sheet, which is available on request via the local NXP Semiconductors sales office. In case of any inconsistency or conflict with the short data sheet, the full data sheet shall prevail.

17.3 Disclaimers

General — Information in this document is believed to be accurate and reliable. However, NXP Semiconductors does not give any representations or warranties, expressed or implied, as to the accuracy or completeness of such information and shall have no liability for the consequences of use of such information.

Right to make changes — NXP Semiconductors reserves the right to make changes to information published in this document, including without limitation specifications and product descriptions, at any time and without notice. This document supersedes and replaces all information supplied prior to the publication hereof.

Suitability for use — NXP Semiconductors products are not designed, authorized or warranted to be suitable for use in medical, military, aircraft, space or life support equipment, nor in applications where failure or malfunction of a NXP Semiconductors product can reasonably be expected to result in personal injury, death or severe property or environmental damage. NXP Semiconductors accepts no liability for inclusion and/or use of NXP Semiconductors products in such equipment or applications and therefore such inclusion and/or use is at the customer's own risk.

Applications — Applications that are described herein for any of these products are for illustrative purposes only. NXP Semiconductors makes no representation or warranty that such applications will be suitable for the specified use without further testing or modification.

Limiting values — Stress above one or more limiting values (as defined in the Absolute Maximum Ratings System of IEC 60134) may cause permanent damage to the device. Limiting values are stress ratings only and operation of the device at these or any other conditions above those given in the Characteristics sections of this document is not implied. Exposure to limiting values for extended periods may affect device reliability.

Terms and conditions of sale — NXP Semiconductors products are sold subject to the general terms and conditions of commercial sale, as published at <http://www.nxp.com/profile/terms>, including those pertaining to warranty, intellectual property rights infringement and limitation of liability, unless explicitly otherwise agreed to in writing by NXP Semiconductors. In case of any inconsistency or conflict between information in this document and such terms and conditions, the latter will prevail.

No offer to sell or license — Nothing in this document may be interpreted or construed as an offer to sell products that is open for acceptance or the grant, conveyance or implication of any license under any copyrights, patents or other industrial or intellectual property rights.

17.4 Licenses

Purchase of NXP <xxx> components

<License statement text>

17.5 Patents

Notice is herewith given that the subject device uses one or more of the following patents and that each of these patents may have corresponding patents in other jurisdictions.

<Patent ID> — owned by <Company name>

17.6 Trademarks

Notice: All referenced brands, product names, service names and trademarks are the property of their respective owners.

<Name> — is a trademark of NXP B.V.

18. Contact information

For additional information, please visit: <http://www.nxp.com>

For sales office addresses, send an email to: salesaddresses@nxp.com

19. Tables

Table 1.	Ordering information	1
Table 2.	Pin description	3
Table 3.	Limiting values	10
Table 4.	Thermal characteristics	11
Table 5.	Characteristics	11
Table 6.	Latch-up	13
Table 7.	UBA2013 parameters (typical)	15
Table 8.	Revision history	18

UNCLASSIFIED

[continued >>](#)

DRAFT
DRAFT
DRAFT
DRAFT
DRAFT
DRAFT
DRAFT
DRAFT
DRAFT
DRAFT
DRAFT
DRAFT
DRAFT
DRAFT
DRAFT
DRAFT
DRAFT
DRAFT
DRAFT
DRAFT
DRAFT

20. Figures

Fig 1.	Block diagram of UBA2013/L3.....	2
Fig 2.	Pin configuration for UBA2013/L3	3
Fig 3.	Oscillator timing	4
Fig 4.	Excess charge control	6
Fig 5.	PFC block	9
Fig 6.	Application diagram of UBA2013L/3	14
Fig 7.	Package outline SOT109-1 (SO16)	16
Fig 8.	State diagram and state transitions	17

UNCLASSIFIED

continued >>

21. Contents

1	General description	1	17.6	Trademarks	19
2	Features	1	18	Contact information	19
2.1	Half bridge	1	19	Tables	20
2.2	PFC	1	20	Figures	21
3	Applications	1	21	Contents	22
4	Ordering information	1			
5	Block diagram	2			
6	Pinning information	3			
6.1	Pinning	3			
6.2	Pin description	3			
7	Functional description	4			
7.1	Start-up state	4			
7.2	Half bridge oscillator	4			
7.3	Oscillating state	4			
7.4	Preheat state	5			
7.5	Ignition state	5			
7.6	Burn state	6			
7.7	Capacitive mode protection	6			
7.8	Stop function	6			
7.9	End-of-life protection	7			
7.10	Non-oscillating state	7			
7.11	Start-up state	7			
7.12	Stop state	7			
7.13	VddLow state	7			
7.14	PFC function	8			
7.15	VO-low condition	8			
7.16	State and transition diagrams	9			
7.17	Charge coupling	9			
8	Limiting values	10			
9	Thermal characteristics	11			
10	Characteristics	11			
11	Latch-up	13			
12	Application information	14			
12.1	Design equations	15			
13	Test information	15			
14	Package outline	16			
15	Appendix	17			
15.1	State diagram and state transitions	17			
16	Revision history	18			
17	Legal information	19			
17.1	Data sheet status	19			
17.2	Definitions	19			
17.3	Disclaimers	19			
17.4	Licenses	19			
17.5	Patents	19			

Please be aware that important notices concerning this document and the product(s) described herein, have been included in section 'Legal information'.



© NXP B.V. 2007.

All rights reserved.

For more information, please visit: <http://www.nxp.com>

For sales office addresses, please send an email to: salesaddresses@nxp.com

Date of release: 23 February 2007

Document identifier: UBA2013L_1