

UBA2025

CFL power IC

Rev. 01 — 16 October 2009

Product data sheet

1. General description

The UBA2025 is a high voltage power IC intended to drive and control a Compact Fluorescent Lamp (CFL). It contains a half bridge power circuit, an oscillator, and a control circuit for starting up, preheating, ignition, lamp burning, and protection.

2. Features

- Two internal 600 V, 3 Ω max NMOST half bridge powers
- For steady state half bridge currents up to 280 mA
- For ignition half bridge currents up to 1.5 A
- Adjustable preheat and ignition time
- Adjustable preheat current
- Adjustable lamp power
- Lamp temperature stress protection at higher mains voltages
- Capacitive mode protection
- Protection against too low a drive voltage for the power MOSFETs.

3. Applications

- 5 W to 25 W CFLs provided that the maximum junction temperature is not exceeded.

4. Ordering information

Table 1. Ordering information

Type number	Package		
	Name	Description	Version
UBA2025T	SO16L	plastic small outline package; 16 leads; body width 7.5 mm	SOT162-1

5. Block diagram

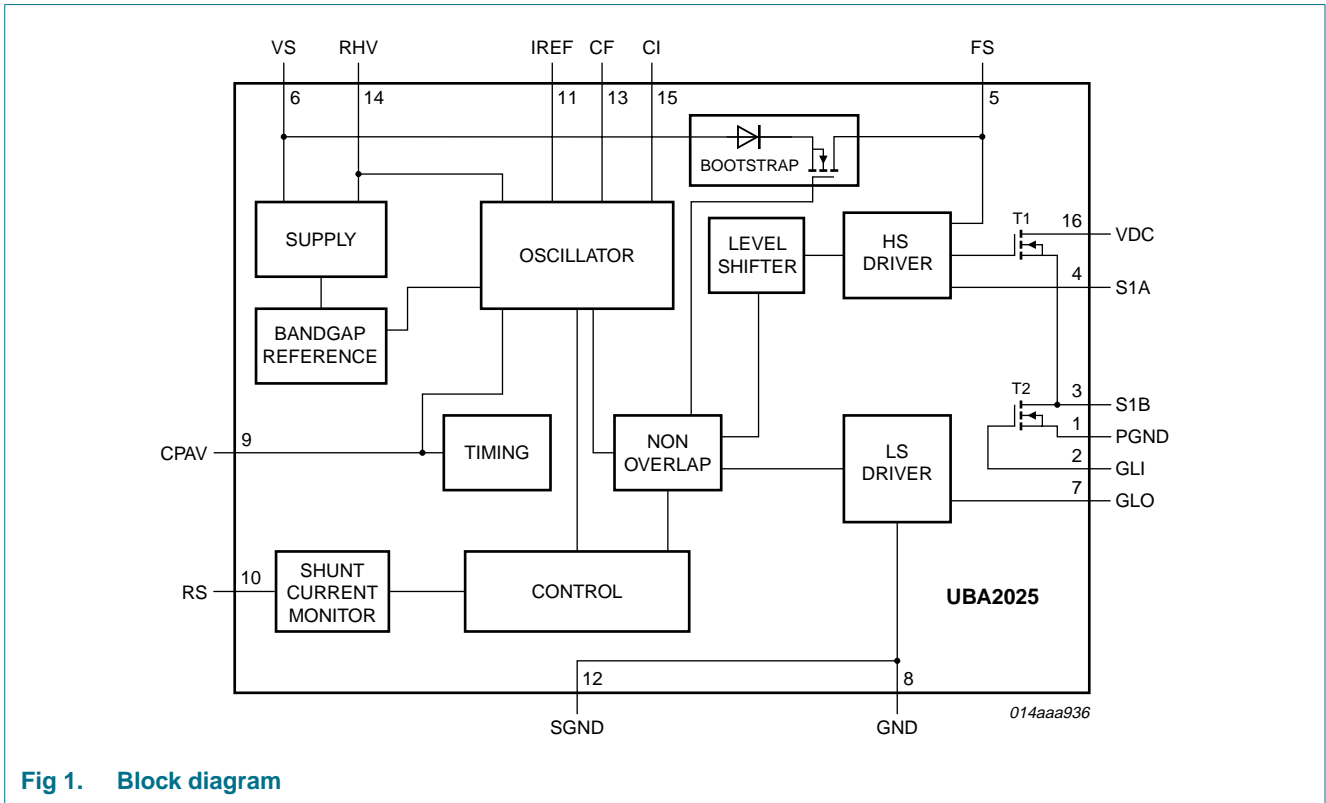

Fig 1. Block diagram

6. Pinning information

6.1 Pinning

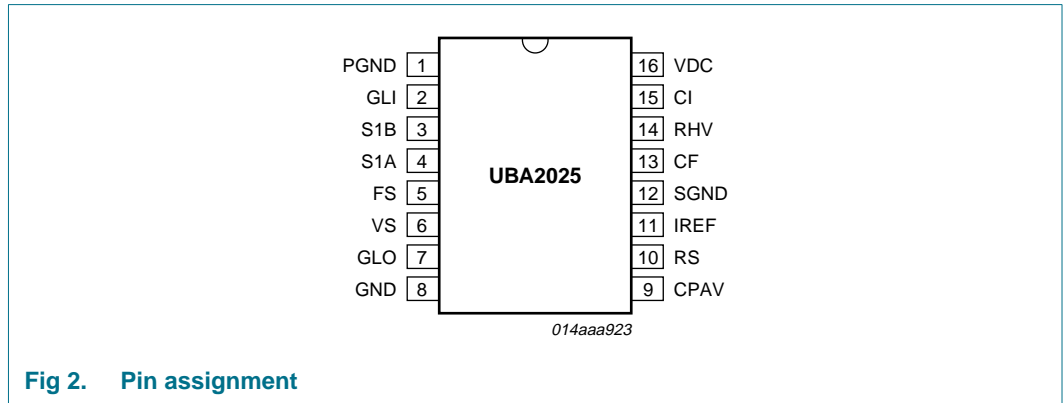

Fig 2. Pin assignment

6.2 Pin description

Table 2. Pin description

Symbol	Pin	Description
PGND	1	power ground
GLI	2	LS gate power MOSFET, must be connected to GLO
S1B	3	half bridge point, must be connected to S1A
S1A	4	half bridge point, must be connected to S1B
FS	5	floating supply
VS	6	IC supply
GLO	7	LS driver output, must be connected to GLI
GND	8	diepad ground
CPAV	9	preheat and averaging capacitor
RS	10	current monitoring input
IREF	11	reference resistor
SGND	12	signal ground
CF	13	oscillator capacitor
RHV	14	start-up/feed forward input
CI	15	integrating capacitor
VDC	16	high voltage power input

7. Functional description

7.1 Introduction

The IC is an integrated circuit for electronically ballasted compact fluorescent lamps and its derivatives, up to a nominal mains voltage of 230 V (RMS). It provides all the necessary functions for proper preheat, ignition and on-state operation of the lamp. Besides the control function, the IC provides the level shift and drive for the two internal power MOSFETs.

7.2 Initial start-up

Initial start-up is achieved by charging CS9 (see [Figure 6](#)) with the current applied to pin RHV. The start-up of the circuit is such that (see [Figure 1](#)) T2 shall be conductive and T1 shall be non-conductive, in order to make sure that C_{BOOT} gets charged. This start-up state is reached for a supply voltage V_{rst} , this is the voltage level at pin VS at which the circuit will be reset to the initial state and maintained until the low voltage supply (V_{VS}) reaches a value of $V_{startup}$.

7.3 Oscillation

If the low voltage supply (V_{VS}) has reached the value of $V_{startup}$ the circuit starts oscillating in the preheat state. The internal oscillator is a current-controlled circuit which generates a sawtooth waveform. The frequency of the sawtooth is determined by the capacitor CF and the current out of pin CF (mainly set by R_{REF}). The sawtooth frequency is twice the frequency of the signal across the load. The IC brings alternately the power MOSFETs T1 and T2 into conduction with a duty cycle of approximately 50%. [Figure 3](#) represents the timing of the IC. The circuit block 'non-overlap' generates a non-overlap time t_{no} when T1 and T2 are not conducting. This is dependent on the reference current.

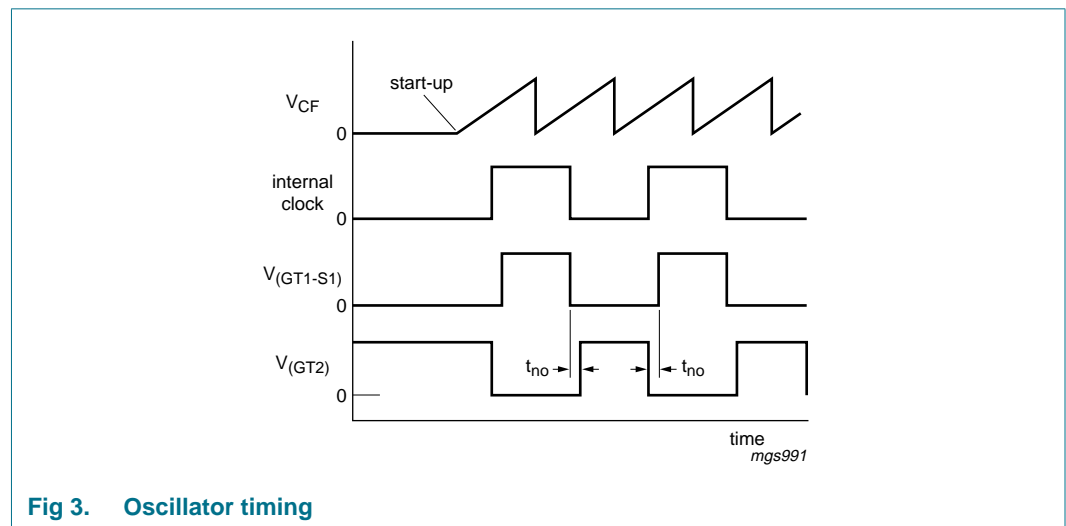

Fig 3. Oscillator timing

7.4 Operation in preheat mode

The circuit starts oscillating at a frequency of approximately $2.5f_{btm}$ (108 kHz). The frequency will gradually decrease until a defined value of the current through R_{SHUNT} is reached (see [Figure 4](#)). The slope of the decrease in frequency is determined by the

capacitor connected to pin CI. The frequency during preheating will be approximately 90 kHz. This frequency is well above the resonant frequency of the load, which means that the lamp is off. The load consists of L2, C5 and the electrode resistance only (see Figure 6). The preheat time is determined by the capacitor connected to pin CPAV. The circuit can be locked in the preheat state by connecting pin CPAV to ground. During preheating the circuit monitors the load current by measuring the voltage drop over external resistor R_{SHUNT} at the end of conduction of T2 with decision level V_{shunt} . The frequency is decreased as long as $V_{RS} > V_{shunt}$. The frequency is increased for $V_{RS} < V_{shunt}$.

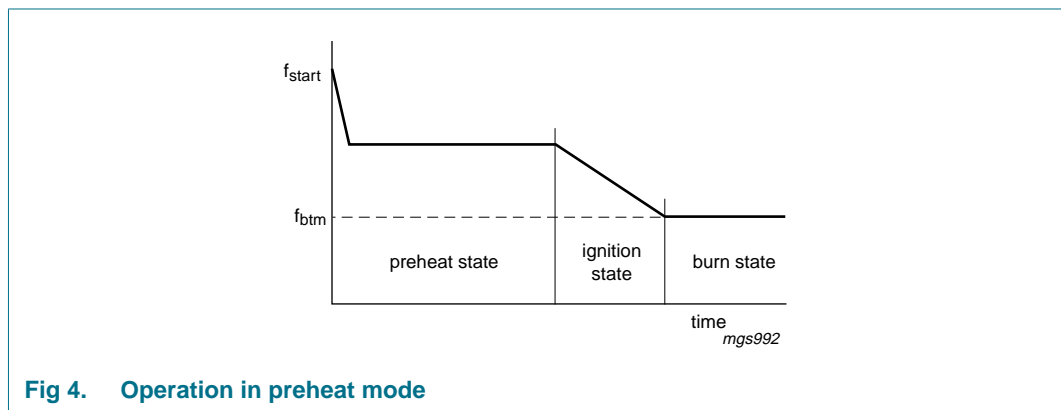

Fig 4. Operation in preheat mode

7.5 Ignition state

The RS current monitoring function changes from V_{shunt} regulation to capacitive mode protection at the end of the preheat time. Normally this results in a further frequency decrease down to the bottom frequency f_{btm} (approximately 43 kHz). The frequency change per ms is lowered with respect to the frequency change in the preheat mode. During the downward frequency sweep the circuit sweeps through the resonant frequency of the load. A high voltage will then appear across the lamp. This voltage will normally ignite the lamp.

7.6 Failure to ignite

Excessive current levels may occur when the lamp fails to ignite. The IC does not limit these currents in any manner.

7.7 Transition to the burn state

Assuming that the lamp has ignited during the downward frequency sweep, the frequency normally decreases to the bottom frequency. The IC can transit to the burn state in two ways:

- In the event that the bottom frequency is not reached, the transition is made after reaching the ignition time t_{ign} .
- As soon as the bottom frequency is reached.

The bottom frequency is determined by resistor R_{IREF} and capacitor CF.

7.8 Feed forward frequency

Above a defined voltage level at pin VDC the oscillation frequency also depends on the supply voltage of the half bridge (see [Figure 5](#)). The current for the current controlled oscillator is in this feed forward range and is derived from the current through R_{HV} (this is similar to pin RHV current). The feed forward frequency is proportional to the average value of the current (within its operating range) through R_{HV} . The feed forward frequency is clamped for currents beyond the operating range (i.e. between 1.0 mA and 1.6 mA). In order to prevent feed forward of the ripple on the input voltage on pin VDC, the ripple is filtered out. The capacitor connected to pin CPAV is used for this purpose. This pin is also used in the preheat state and the ignition state for timing (t_{ph} and t_{ign}).

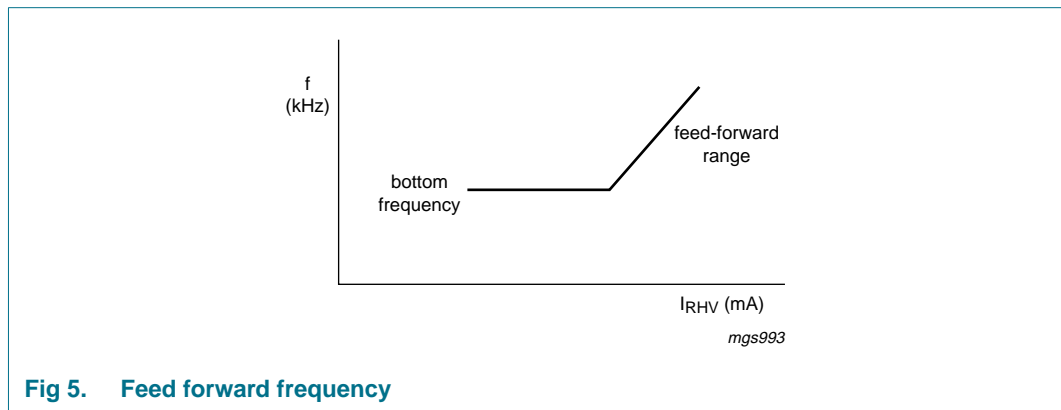

Fig 5. Feed forward frequency

7.9 Capacitive mode

When the preheat mode is completed, the IC will protect the power circuit against losing the zero voltage switching condition and getting too close to the capacitive mode of operation. This is detected by monitoring the voltage across R_{SHUNT} . If the voltage at pin RS is below $V_{th(capm)}$ the capacitive mode threshold voltage at the time of turn-on of T2, then capacitive mode operation is assumed. Consequently, the frequency will be increased as long as the capacitive mode is detected. The frequency decreases down to the feed forward frequency if no capacitive mode is detected. Frequency modulation is achieved via pin CI.

7.10 IC supply

Initially, the IC is supplied from the bus voltage VDC by the current through R_{HV} . This current charges the supply capacitor CS9 via an internal diode. As soon as V_S exceeds $V_{startup}$, the circuit starts oscillating. After the preheat phase is finished, pin RHV is connected to an internal resistor (R_{RHV}); prior to this the pin is internally connected to pin VS. The voltage level at pin RHV thus drops from $(V_S + V_d)$ to a voltage equal to the RHV pin current $\times R_{RHV}$. The capacitor CS9 at pin VS will now be charged via the snubber capacitor CS7. Excess charge is drained by an internal clamp that turns on at the clamp voltage (V_{clamp}) on pin VS.

7.11 Minimum gate source voltage of T1 and T2

The high side driver is supplied via capacitor C_{BOOT} . C_{BOOT} is charged via the bootstrap switch during the on-periods of T2. The IC stops oscillating at a voltage level V_{stop} . Given a maximum charge consumption on the gate of T1 (G1) of 1 nC/V, this safeguards the minimum drive voltages $V_{(G1-S1)}$ for the high side driver; see [Table 3](#).

Table 3. Minimum gate voltages

Frequency	Voltage
< 75 kHz	8 V (min.)
75 kHz to 80 kHz	7 V (min.)
> 85 kHz	6 V (min.)

The drive voltage at gate of T2 (G2) will exceed the drive voltage of the high side driver.

7.12 Frequency and change in frequency

At any point in time during oscillation, the circuit will operate between f_{btm} and f_{start} . Any change in frequency will be gradual, no steps in frequency will occur. Changes in frequency caused by a change in voltage at pin CI, show a rather constant df/dt over the entire frequency range. The following rates are realised (at a frequency of 85 kHz and a 100 nF connected to pin CI):

- For any increase in frequency the df/dt will be between 15 kHz/ms and 37.5 kHz/ms
- During preheat and normal operation: the df/dt for a decrease in frequency is between -6 kHz/ms and -15 kHz/ms
- During the ignition phase: the df/dt for a decrease in frequency is between -150 Hz/ms and -375 Hz/ms.

7.13 Ground pins

Pin PGND and pin GND are the ground references of the IC with respect to the application. Pin SGND provides a local ground reference for the components connected to pins CPAV, CI, IREF and CF. Other external connections to pin SGND are not preferred. The sum of currents flowing out of the pins CPAV, CI, IREF, CF and SGND must remain zero at any time. Pin GND is internally connected to SGND.

7.14 Charge coupling

Due to parasitic capacitive coupling to the high voltage circuitry, all pins are exposed to a repetitive charge injection. Given the typical application in figure 6, the pins IREF and CF are sensitive to this charge injection. For the rating Q_{coup} a safe functional operation of the IC is guaranteed, independent of the current level. Charge coupling at current levels below 50 μ A will not interfere with the accuracy of the $V_{th(capm)}$ and V_{shunt} levels. Charge coupling at current levels below 20 μ A will not interfere with the accuracy of any parameter.

8. Limiting values

Table 4. Limiting values

Symbol	Parameter	Conditions	Min	Max	Unit
$V_{i(VDC)}$	input voltage on pin VDC	operating	-	556	V
		during 0.5 s	-	600	V
V_{FS}	voltage on pin FS	operating, with respect to S1A and S1B	-	14	V
		during 0.5 s, with respect to S1A and S1B	-	17	V
I_{clamp}	clamp current	during 0.5 s	-	35	mA
I_D	drain current	on T1; pulsed; t_p limited by $T_{j(max)}$; $T < T_{j(max)}$	-	1.5	A
		on T2; pulsed; t_p limited by $T_{j(max)}$; $T < T_{j(max)}$	-	1.5	A
V_I	input voltage	on pin RS; transient of 50 ns	-2.5	+2.5	V
		on pin RS; operating normally	-1.5	+2.5	V
SR	slew rate	pins S1A and S1B with respect to GND	-4	+4	V/ns
T_{amb}	ambient temperature		-40	+150	°C
T_j	junction temperature		-40	+150	°C
T_{stg}	storage temperature		-55	+150	°C
Q_{coup}	coupling charge	at pins IREF and CF; normal operation	-8	+8	pC
V_{ESD}	electrostatic discharge voltage	human body model [1]			
		pins 1, 8, 9, 10, 11, 12, 13, 14, 15	-	3000	V
		pin 4, 5, 6	-	1500	V
		pin 7	-	1000	V
		pin 2, 3, 16	-	< 500	V
		machine model [2]			
		pins 1, 3, 4, 5, 6, 8, 9, 10, 11, 12, 13, 14, 15, 16	-	250	V
		pin 2	-	200	V
pin 7	-	<125	V		

[1] Equivalent to discharging a 100 pF capacitor through a 1.5 kΩ series resistor.

[2] Equivalent to discharging a 200 pF capacitor through a 0.75 μH coil and a 10 Ω resistor.

9. Thermal characteristics

Table 5. Thermal characteristics

Symbol	Parameter	Conditions	Typ	Unit
$R_{th(j-a)}$	thermal resistance from junction to ambient	in free air; SO16L package	80	K/W

10. Characteristics

Table 6. Characteristics

$T_{amb} = 25\text{ °C}$; voltage on pin VS = 11 V; $V_{FS} - S1A$ and $S1B$ voltage= 11 V, GLI and GLO voltage measured with respect to PGND; currents are positive when flowing into the IC; unless otherwise specified.

Symbol	Parameter	Conditions	Min	Typ	Max	Unit
High voltage supply						
I_{leak}	leakage current	high voltage pins	-	-	10	μA
Start-up state						
V_{rst}	reset voltage		4.0	5.5	6.5	V
$V_{startup}$	start-up voltage		11.35	11.95	12.55	V
V_{stop}	stop voltage		9.55	10.15	10.75	V
V_{hys}	hysteresis voltage		1.5	1.8	2.0	V
I_{stb}	standby current	on pin VS	[1] 150	200	250	μA
$V_{(RHV-VS)}$	voltage difference pin RHV and pin VS	RHV pin current = 1.0 mA	0.7	0.8	1.0	V
$\Delta V_{clamp(startup)}$	start-up clamp voltage difference		[2] 0.2	0.3	0.4	V
I_{clamp}	clamp current	VS pin voltage < 17 V	-	14	35	mA
Preheat mode						
f_{start}	start frequency	CI pin voltage = 0 V	98	108	118	kHz
t_g	conduction time	T1; T2; $f_{start} = 108\text{ kHz}$	-	3.2	-	μs
I_{ch}	charge current	on pin CI; pin CI voltage = 0 V; pin RS voltage = -0.3 V	38	44	50	μA
		on pin CPAV; pin CPAV voltage = 1 V	-	6.0	-	μA
I_{dch}	discharge current	on pin CI; pin CI voltage = 0 V; pin RS voltage = -0.9 V	79	93	107	μA
		on pin CPAV; pin CPAV voltage= 1 V	-	5.95	-	μA
t_{ph}	preheat time		599	666	733	μs
$\Delta V_{M(CPAV)}$	peak voltage difference on pin CPAV	measured during preheat timing	-	2.5	-	V
V_{ctrl}	control voltage	at pin RS	[3] -636	-600	-564	mV
Frequency sweep to ignition						
I_{ch}	charge current	on pin CI; CI pin voltage = 1.5 V; $f = 85\text{ kHz}$	0.8	1	1.2	μA
f_{btm}	bottom frequency	pin CI voltage at clamp level	-	42.9	-	kHz
t_{ign}	ignition time		-	625	-	ms
Normal operation						
f_{btm}	bottom frequency	$V_{ctrl} < 1\text{ V}$	42.21	42.90	44.59	kHz
t_g	conduction time	for T1 and T2; $f_{btm} = 43\text{ kHz}$	-	10.2	-	μs
t_{no}	non-overlap time		1.05	1.4	1.75	μs
I_{tot}	total current	for supply; $f = 43\text{ kHz}$	-	-	1.6	mA
V_{ctrl}	control voltage	for capacitive mode control	[4] 0	20	40	mV
V_{ref}	reference voltage		[5] 2.425	2.5	2.575	V
R_{on}	on-state resistance	half bridge power	-	-	3	Ω

Table 6. Characteristics ...continued

$T_{amb} = 25\text{ }^{\circ}\text{C}$; voltage on pin VS = 11 V; $V_{FS} - S1A$ and $S1B$ voltage= 11 V, GLI and GLO voltage measured with respect to PGND; currents are positive when flowing into the IC; unless otherwise specified.

Symbol	Parameter	Conditions	Min	Typ	Max	Unit
$R_{on(150)}/R_{on(25)}$	on-state resistance ratio (150 °C to 25 °C)		-	2.7	-	
$V_{Fd(bs)}$	bootstrap diode forward voltage	$I_{FS} = 5\text{ mA}$	0.6	1.0	1.4	V
feed forward						
$R_{i(RHV)}$	input resistance on pin RHV		1.54	2.2	2.86	kΩ
$I_{i(RHV)}$	input current on pin RHV	during normal operation	[6] 0		1	mA
f_{ff}	feed forward frequency	pin RHV current = 0.75 mA	60.4	63.6	66.15	kHz
		pin RHV current = 1 mA	80.3	84.5	88.2	kHz
$f_{ff(ratio)}$	feed forward frequency ratio	pin RHV current = 1 mA	[7] 0.9	1.0	1.1	
R_s	series resistance	CPAV switch; pin CPAV current = 100 μA	0.75	1.5	2.25	kΩ
R_{CPAV}	resistance on pin CPAV	used with C_{CPAV} for averaging; CPAV pin current = 10 μA	22.4	32	41.6	kΩ

- [1] The start-up supply current is specified in a temperature (T_{vj}) range of 0 °C to 125 °C. For $T_{vj} < 0\text{ }^{\circ}\text{C}$ and $T_{vj} > 125\text{ }^{\circ}\text{C}$ the start-up supply current is < 350 μA.
- [2] The clamp margin is defined as the voltage difference between turn-on of the clamp and start of oscillation. The clamp is in the off-state at start of oscillation.
- [3] Data sampling of $V_{th(capm)}$ is performed at the end of conduction of T2.
- [4] Data sampling of $V_{th(capm)}$ is performed at the start of conduction of T2.
- [5] Within the allowed range of R_{IREF} , defined as 30 kΩ +10%.
- [6] The input current at pin RHV may increase to 1.6 mA during voltage transient on pin VDC. Only for pin RHV currents beyond approximately 550 mA the oscillator frequency is proportional to the pin RHV current.
- [7] The symmetry is best calculated using $f_{ff(ratio)}$ where $f_{ff(ratio)} = T1$ total time divided by the T2 total time with the T1 total time the time between turn-off of G2 and turn-off of G1, and the T2 total time the time between turn-off of G1 and turn-off of G2.

11. Application information

11.1 Design equations

- Bottom frequency:

$$f_{btm} = \frac{I}{2 \times [(C_f + C_{par}) \times (X1 \times R_{IREF} - R_{int})] + t} \text{ (Hz)}$$

- Feed forward frequency:

$$f_{ff} = \frac{I}{2 \times [(C_f + C_{par}) \times \left(\frac{X2 \times V_{ref} \times R_{HV}}{V_{i(VDC)}} - R_{int} \right)] + t} \text{ (Hz)}$$

Where:

- X1 = 3.68
- X2 = 22.28
- t = 0.4 μs
- R_{int} = 3 kΩ
- C_{par} = 4.7 pF
- V_{ref} = 2.5 V
- V_{i(VDC)} = 300 V (nominal)
- R_{HV} = 560 KΩ (see [Figure 6](#))
- Operating frequency = f_{btm(max)}, f_{ff(max)}, and f_{cm(max)}

Where:

- f_{btm} = bottom frequency
- f_{ff(max)} = maximum feed forward frequency
- f_{cm(max)} = maximum frequency due to capacitive mode detection

- Preheat time:

$$t_{ph} = \frac{C_{CP}}{150 \text{ nF}} \times \frac{R_{ref}}{30 \text{ k}\Omega} \text{ (s)}$$

- Ignition time:

$$t_{ign} = \frac{15}{16} \times t_{ph} \text{ (s)}$$

- Non-overlap time:

$$t_{no} = 1.4 \text{ }\mu\text{s} \times \frac{R_{ref}}{30 \text{ k}\Omega}$$

11.2 Application diagram

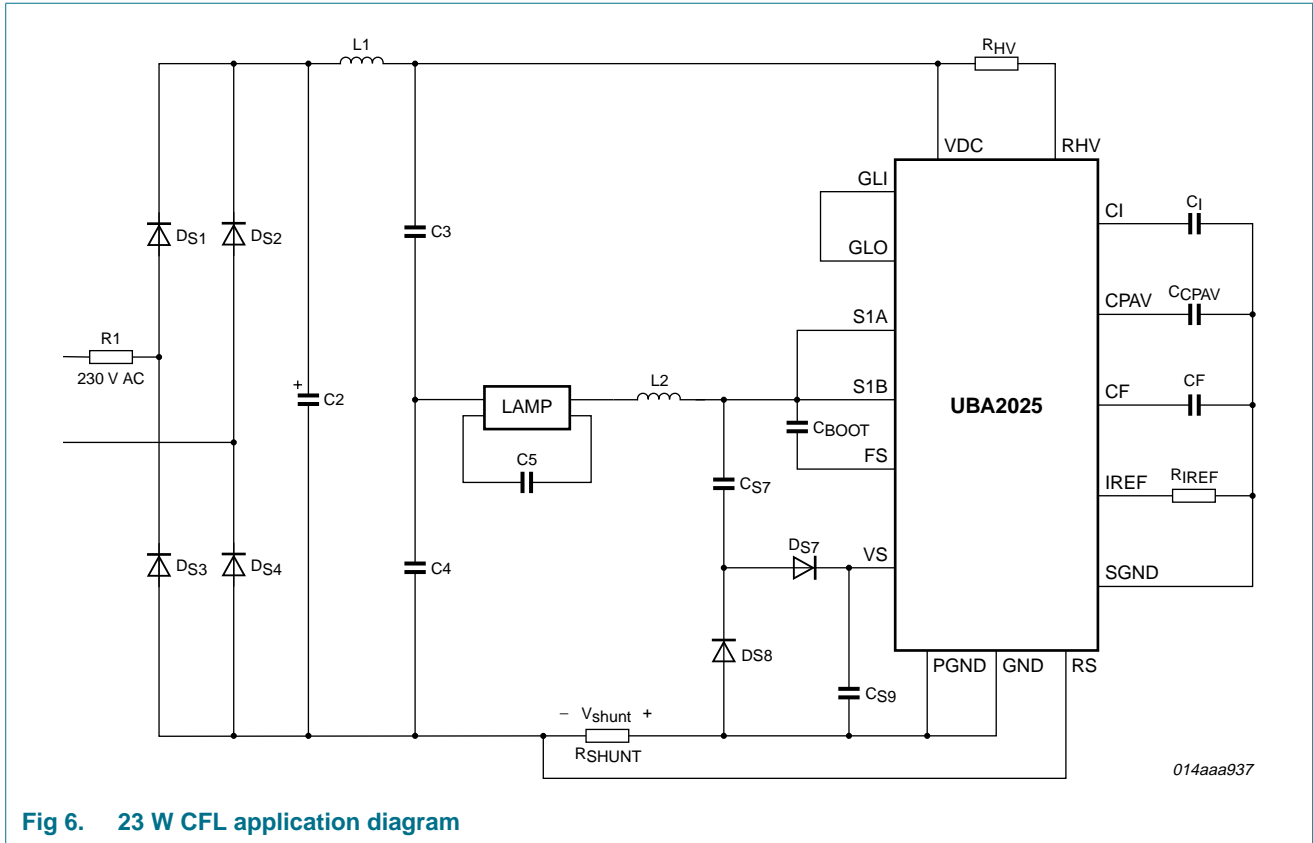

Fig 6. 23 W CFL application diagram

Table 7. 23 W CFL application component values

Component type	Component name	Value	Description
diodes	DS1-DS4	IN4007	bridge rectifier
	DS7, DS8	IN4148	limiting and charge pump
resistors	R1	10 Ω	inrush or fusistor
	R _{IREF}	30 kΩ	reference
	R _{HV}	560 kΩ	start-up and feed forward frequency
	R _{SHUNT}	1.1 Ω	sensing (2 W)
inductors	L1	1.8 mH	input mains filter
	L2	3 mH	resonant
capacitors	C2	5.6 μH; 400 V	mains buffer
	C3, C4	100 nF; 200 V	DC blocking
	C5	3.9 nF; 630 V	resonant
	C ₁	47 nF	integrating
	C _{CPAV}	100 nF	preheat and averaging
	CF	100 pF	internal reference oscillator
	C _{BOOT}	100 nF; 400 V	bootstrap
	CS7	150 pF; 400 V	charge pump and dv/dt limiting

Table 7. 23 W CFL application component values

Component type	Component name	Value	Description
capacitor	CS9	100 nF	decoupling
CFL	E27 CFL	23 W	CFL E27 type, 23 W
IC	UBA2025T	SO16L, SOT162-1	control IC with integrated power MOSFETs

12. Package outline

SO16: plastic small outline package; 16 leads; body width 7.5 mm

SOT162-1

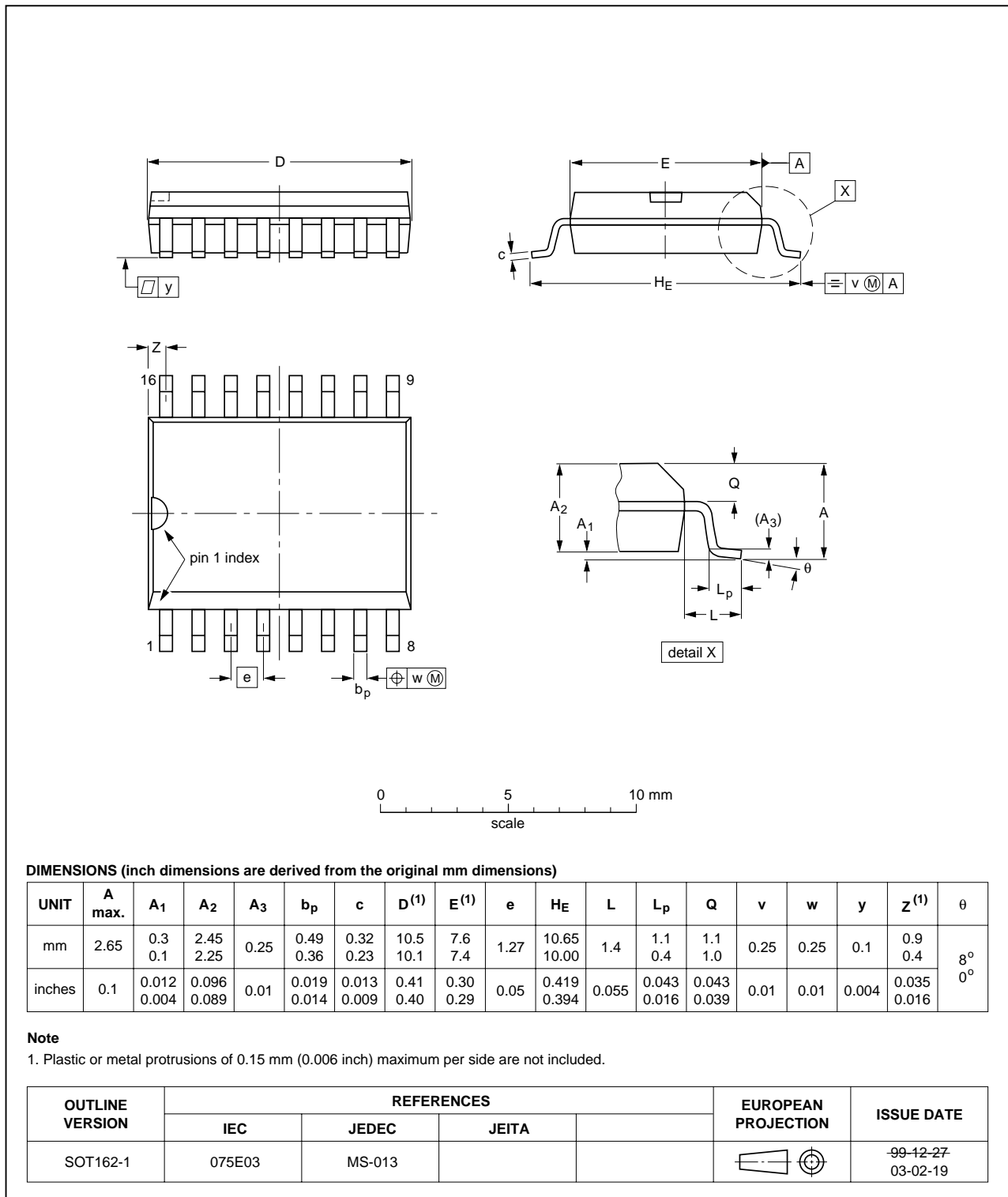

Fig 7. Package outline SOT162-1 (SO16)

13. Abbreviations

Table 8. Abbreviations

Acronym	Description
CFL	Compact Fluorescent Lamp
NMOST	Negative Channel Metal-Oxide Semiconductor
MOSFET	Metal-Oxide-Semiconductor Field-Effect Transistors
LS	Low Side

14. Revision history

Table 9. Revision history

Document ID	Release date	Data sheet status	Change notice	Supersedes
UBA2025_1	20091016	Product data sheet	-	-

15. Legal information

15.1 Data sheet status

Document status ^{[1][2]}	Product status ^[3]	Definition
Objective [short] data sheet	Development	This document contains data from the objective specification for product development.
Preliminary [short] data sheet	Qualification	This document contains data from the preliminary specification.
Product [short] data sheet	Production	This document contains the product specification.

[1] Please consult the most recently issued document before initiating or completing a design.

[2] The term 'short data sheet' is explained in section "Definitions".

[3] The product status of device(s) described in this document may have changed since this document was published and may differ in case of multiple devices. The latest product status information is available on the Internet at URL <http://www.nxp.com>.

15.2 Definitions

Draft — The document is a draft version only. The content is still under internal review and subject to formal approval, which may result in modifications or additions. NXP Semiconductors does not give any representations or warranties as to the accuracy or completeness of information included herein and shall have no liability for the consequences of use of such information.

Short data sheet — A short data sheet is an extract from a full data sheet with the same product type number(s) and title. A short data sheet is intended for quick reference only and should not be relied upon to contain detailed and full information. For detailed and full information see the relevant full data sheet, which is available on request via the local NXP Semiconductors sales office. In case of any inconsistency or conflict with the short data sheet, the full data sheet shall prevail.

15.3 Disclaimers

General — Information in this document is believed to be accurate and reliable. However, NXP Semiconductors does not give any representations or warranties, expressed or implied, as to the accuracy or completeness of such information and shall have no liability for the consequences of use of such information.

Right to make changes — NXP Semiconductors reserves the right to make changes to information published in this document, including without limitation specifications and product descriptions, at any time and without notice. This document supersedes and replaces all information supplied prior to the publication hereof.

Suitability for use — NXP Semiconductors products are not designed, authorized or warranted to be suitable for use in medical, military, aircraft, space or life support equipment, nor in applications where failure or malfunction of an NXP Semiconductors product can reasonably be expected to result in personal injury, death or severe property or environmental

damage. NXP Semiconductors accepts no liability for inclusion and/or use of NXP Semiconductors products in such equipment or applications and therefore such inclusion and/or use is at the customer's own risk.

Applications — Applications that are described herein for any of these products are for illustrative purposes only. NXP Semiconductors makes no representation or warranty that such applications will be suitable for the specified use without further testing or modification.

Limiting values — Stress above one or more limiting values (as defined in the Absolute Maximum Ratings System of IEC 60134) may cause permanent damage to the device. Limiting values are stress ratings only and operation of the device at these or any other conditions above those given in the Characteristics sections of this document is not implied. Exposure to limiting values for extended periods may affect device reliability.

Terms and conditions of sale — NXP Semiconductors products are sold subject to the general terms and conditions of commercial sale, as published at <http://www.nxp.com/profile/terms>, including those pertaining to warranty, intellectual property rights infringement and limitation of liability, unless explicitly otherwise agreed to in writing by NXP Semiconductors. In case of any inconsistency or conflict between information in this document and such terms and conditions, the latter will prevail.

No offer to sell or license — Nothing in this document may be interpreted or construed as an offer to sell products that is open for acceptance or the grant, conveyance or implication of any license under any copyrights, patents or other industrial or intellectual property rights.

Export control — This document as well as the item(s) described herein may be subject to export control regulations. Export might require a prior authorization from national authorities.

15.4 Trademarks

Notice: All referenced brands, product names, service names and trademarks are the property of their respective owners.

16. Contact information

For more information, please visit: <http://www.nxp.com>

For sales office addresses, please send an email to: salesaddresses@nxp.com

17. Contents

1	General description	1
2	Features	1
3	Applications	1
4	Ordering information	1
5	Block diagram	2
6	Pinning information	3
6.1	Pinning	3
6.2	Pin description	3
7	Functional description	4
7.1	Introduction	4
7.2	Initial start-up	4
7.3	Oscillation	4
7.4	Operation in preheat mode	4
7.5	Ignition state	5
7.6	Failure to ignite	5
7.7	Transition to the burn state	5
7.8	Feed forward frequency	6
7.9	Capacitive mode	6
7.10	IC supply	6
7.11	Minimum gate source voltage of T1 and T2	6
7.12	Frequency and change in frequency	7
7.13	Ground pins	7
7.14	Charge coupling	7
8	Limiting values	8
9	Thermal characteristics	8
10	Characteristics	9
11	Application information	11
11.1	Design equations	11
11.2	Application diagram	12
12	Package outline	14
13	Abbreviations	15
14	Revision history	15
15	Legal information	16
15.1	Data sheet status	16
15.2	Definitions	16
15.3	Disclaimers	16
15.4	Trademarks	16
16	Contact information	16
17	Contents	17

Please be aware that important notices concerning this document and the product(s) described herein, have been included in section 'Legal information'.



© NXP B.V. 2009.

All rights reserved.

For more information, please visit: <http://www.nxp.com>

For sales office addresses, please send an email to: salesaddresses@nxp.com

Date of release: 16 October 2009

Document identifier: UBA2025_1